

# BATHROOM FANS & KITS

## COMMERCIAL TF 200 TRANQUIL BATHROOM FAN

TF200 bathroom fan offers higher air delivery for commercial applications. The built-in backdraft damper prevents outside air from entering and keeps tempered air inside a room when the fan is not operating.

### FEATURES & BENEFITS

- Superior ventilation & efficient performance
- Clean, simple grille design
- Galvanized steel housing w/corrosion resistant finish
- Easy installation
- Install to joist with included hanger brackets & vibration isolators
- Built-in backdraft damper
- Efficient AC motor
- 120V, 60 Hz operation
- Automatic reset thermal overload protection
- Fits 6" duct



### ACCESSORIES / OPTIONS

- Controls - pages 36-37
- Accessories - pages 38-39

MODEL	MANUFACTURE CODE	PERFORMANCE			
		CFM 0.1" SP	SONES	WATTS	POWER SUPPLY
TF200	SEC200	220	2.5	31.3	120V / 60 Hz

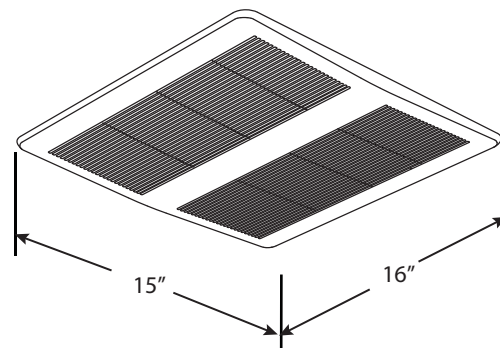
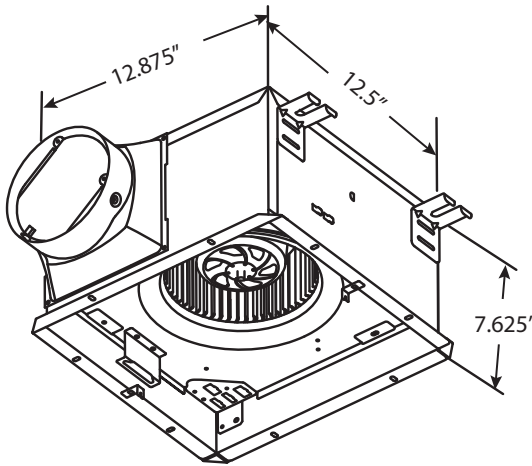

MODEL	DUCT DIA.	GRILLE SIZE	DIMENSIONS IN INCHES*			WT LBS
			HOUSING SIZE			
			L	W	H	
TF200	6	15 X 16	12.875	12.5	7.625	8.0

\*DO NOT USE FOR CONSTRUCTION

CONSULT FACTORY FOR CERTIFIED PRINTS

