

SHOPFAN

FROM THE BASIC 6 FAMILY OF FANS

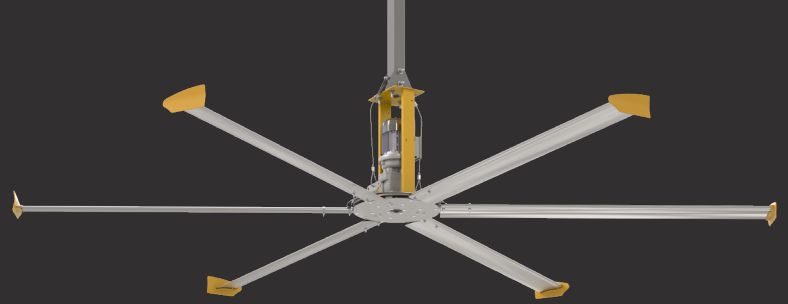

Lightweight and pre-wired for easy installation, ShopFan by Big Ass Fans is an impressive and economical fan package for workshops, small manufacturing facilities, and industrial spaces. Easy installation, superb performance, and year-round energy savings — just what you'd expect from Big Ass Fans.

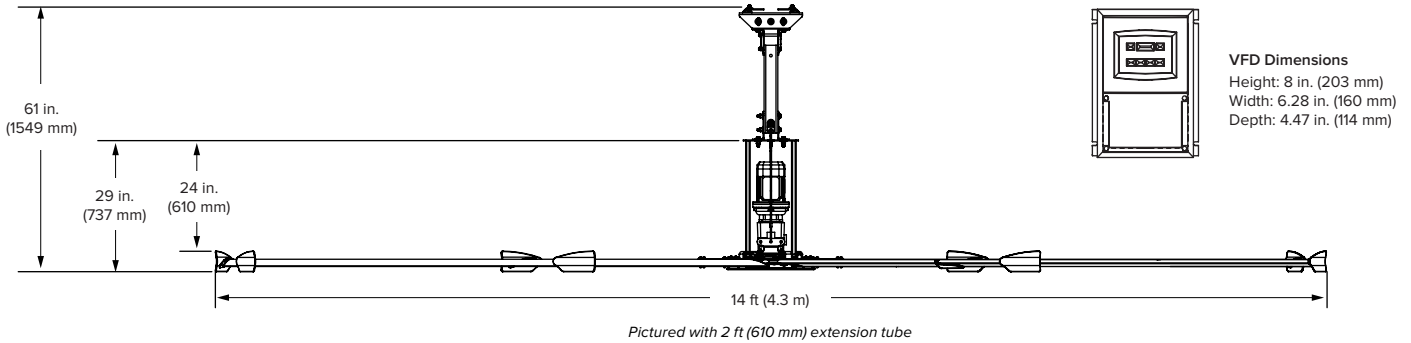

Technical Specifications

Model	Diameter (A)	Weight ¹	Max speed	Airfoil clearances ²	Input power and required breaker	Max amps	Motor	Max Operating Temperature
PF62-14	14 ft (4.3 m)	192 lb (87 kg)	110 RPM	10 ft (3 m) above floor 2 ft (0.6 m) on sides 5 ft (1.5 m) below ceiling deck	200–240 VAC, 50/60 Hz, 1 ϕ , 25 A	13.3 A	1.5 hp (1.1 kW)	104°F (40°C)

Construction Features

Airfoils	Motor and Drive	Hub System	Controller	Mounting	Multi-Point Safety ³
Six patented airfoils (mill finish) Cuffed winglets eliminate wind noise (BAF yellow)	Industrial-grade motor and gearbox feature inline helical-cut gears for efficient, durable, and reliable operation	Machine-cut precision components for uniform load distribution	NEMA 4X variable speed drive is pre-wired to the motor with a 50 ft (15.2 m) cord Includes a 10 ft (3 m) AC supply power cord	Standard upper mount installs to I-beams and bar joists Optional kits allow for mounting to solid beams and purlins	Double safety cable system, airfoil retainers, hub safety clips, Grade 8 hardware, and fire relay (must be wired if required by local code)

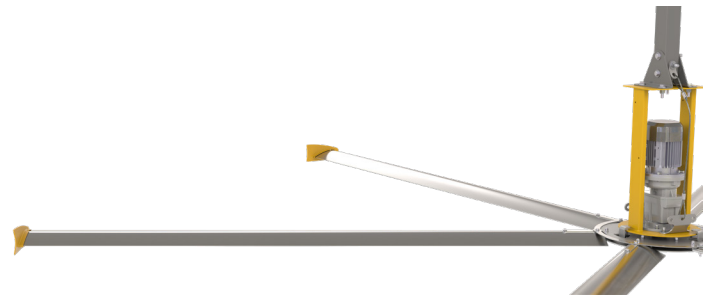

Lead times may vary.
See full warranty for coverage information.

¹ Weight does not include mount or extension tube.
² Measure the distance from the tip of the winglet to the ceiling or major obstruction.



USA
BIGASSFANS.COM
877-244-3267

CANADA
BIGASSFANS.COM
844-924-4277

AUSTRALIA
BIGASSFANS.COM/AU
1300 244 277

SINGAPORE
BIGASSFANS.COM/SG
65 6709 8500