



# SXB - BELT DRIVE WALL SUPPLY FANS

Designed for commercial and light duty industrial supply applications - Factories, Warehouses, Underground parking garages, etc.

These fans are typically used for low pressure applications with little to no duct work. The SXB series is designed and constructed for efficient and economical operation at low speeds and low noise levels. Please see previous page for exhaust fan applications.

This fan is complete with cabinet, motorized steel control damper and guard.

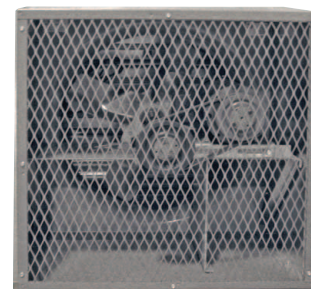

BACK VIEW

Photo above and Dimension illustration below show fan with cabinet, back guard and motorized steel control dampers (Standard).

## FEATURES

- Heavy gauge steel fan panel with deep spun and flared venturi for maximum efficiency.
- Heavy gauge welded steel motor and bearing supports.
- Galvanized heavy gauge steel fan blades that are statically and dynamically balanced.
- Heavy duty cast iron pillow block bearings.
- TEFC motors are standard.
- All dampers come with Belimo actuators.
- Complete with cabinet, motorized steel control damper and discharge guard.

**Note** Non-stock, made-to-order products are non-returnable and cannot be cancelled.

## DIMENSIONS

MODEL	BLADE DIAMETER	A X A SQUARE	B (BELT DRIVE MOTOR FRAME)	
			56 - 184	213 - 286
SXB24	24"	29.875"	43"	--
SXB30	30"	35.875"	43"	--
SXB36	36"	41.875"	43"	49"
SXB42	42"	47.875"	43"	49"
SXB48	48"	53.875"	43"	49"
SXB54	54"	59.9375"	43"	49"
SXB60	60"	67.9375"	43"	49"

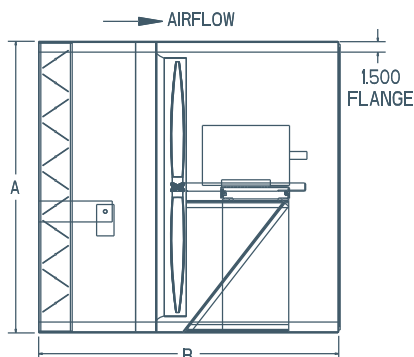

## SPECIFICATIONS

BLADE DIAMETER	MODEL #		RPM	H.P.	dBA @ 5 ft.	CFM @ STATIC PRESSURE					
	SINGLE PHASE	THREE PHASE				0"	1/8"	1/4"	3/8"	1/2"	5/8"
	24"	SXB24CBD10033				SXB24CBD30033*	670	1/3	61.0	3947	3432
	SXB24CBD10050	SXB24CBD30050*	805	1/2	65	4741	4345	3744	2494	-	-
	SXB24CBD10075	SXB24CBD30075*	925	3/4	70.0	5449	5126	4697	4021	2851	-
	SXB24CBD10100	SXB24CBD30100*	1040	1	73.0	6126	5851	5488	5041	4372	3224
30"	SXB30CBD10033	SXB30CBD30033*	470	1/3	59.0	5659	4009	1656	-	-	-
	SXB30CBD10050	SXB30CBD30050*	565	1/2	63.0	6803	5686	3653	1801	-	-
	SXB30CBD10075	SXB30CBD30075*	640	3/4	66.0	7707	6812	5162	3587	1873	-
	SXB30CBD10100	SXB30CBD30100*	715	1	69.0	8610	7840	6622	4835	3611	2084
	SXB30CBD10150	SXB30CBD30150*	830	1 1/2	73.0	9994	9377	8538	7251	5650	4712
36"	SXB36CBD10050	SXB36CBD30050*	410	1/2	59.0	8376	6415	3026	-	-	-
	SXB36CBD10075	SXB36CBD30075*	460	3/4	63.0	9398	7817	4352	2445	-	-
	SXB36CBD10100	SXB36CBD30100*	515	1	67.0	10521	9220	6780	4066	2329	-
	SXB36CBD10150	SXB36CBD30150*	605	1 1/2	71.0	12360	11385	9811	7019	4980	3504
	SXB36CBD10200	SXB36CBD30200*	675	2	73.0	13790	12916	11688	10056	6825	5530
42"	SXB42CBD10075	SXB42CBD30075*	330	3/4	58.0	9992	7292	2853	-	-	-
	SXB42CBD10100	SXB42CBD30100*	390	1	63.0	11808	9857	4899	2943	-	-
	SXB42CBD10150	SXB42CBD30150*	465	1 1/2	68.0	14079	12495	10231	5428	3970	-
	SXB42CBD10200	SXB42CBD30200*	510	2	71.0	15442	14007	12337	7747	5455	4055
	SXB42CBD10300	SXB42CBD30300*	590	3	75.0	17864	16642	15326	13504	9036	6700
48"	SXB48CBD10100	SXB48CBD30100*	330	1	63.0	15859	12661	6157	2806	-	-
	SXB48CBD10150	SXB48CBD30150*	380	1 1/2	67.0	18262	15801	10271	6174	3191	-
	SXB48CBD10200	SXB48CBD30200*	425	2	70.0	20426	18238	15076	8880	6340	3574
	SXB48CBD10300	SXB48CBD30300*	485	3	74.0	23309	21412	19101	15362	9889	7657
	SXB48CBD10500	SXB48CBD30500*	585	5	80.0	28115	26551	24931	22809	20195	14731
54"	SXB54CBD10150	SXB54CBD30150*	310	1 1/2	65.0	20639	17558	8844	4891	2335	-
	SXB54CBD10200	SXB54CBD30200*	345	2	68.0	22604	19784	13464	7498	4419	2087
	SXB54CBD10300	SXB54CBD30300*	400	3	72.0	26207	23807	20686	12521	8769	5883
	SXB54CBD10500	SXB54CBD30500*	475	5	76.0	31121	29226	27028	23815	16463	11676
	SXB54CBD10750	SXB54CBD30750*	545	7 1/2	81.0	35708	34145	32145	30368	27141	21191
60"	SXB60CBD10150	SXB60CBD30150*	275	1 1/2	64.0	23879	19746	10725	5394	2683	-
	SXB60CBD10200	SXB60CBD30200*	300	2	66.0	26050	22238	14927	8470	4649	2399
	SXB60CBD10300	SXB60CBD30300*	345	3	70.0	29957	26750	23322	14120	9596	6071
	SXB60CBD10500	SXB60CBD30500*	420	5	76.0	36470	34164	31028	28247	20069	15074
	SXB60CBD10750	SXB60CBD30750*	485	7 1/2	81.0	42114	40290	37542	35076	32620	26262

For three phase motors, substitute "\*" with "M" for 230/460 volt (If 208V required please specify) or "P" for 575 volt Fan blades tested in accordance with AMCA standard 210, figure 12 dBA ratings shown are measured at 0" static pressure and should be used as a guideline only

Please note this product is currently under review and the dimensions may change. Call for details.