

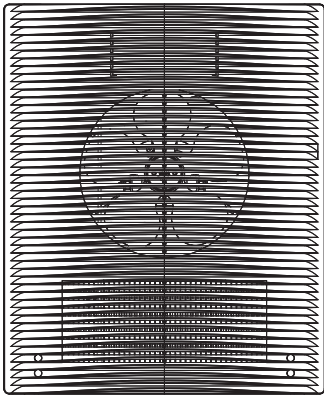

470 Beauty Spot Rd. E, Bennettsville, SC 29512

**SUBMITTAL SHEET
SMART SERIES
DIGITAL FAN-FORCED
HIGH OUTPUT WALL HEATERS
SSAR SERIES**



CAPACITIES
540 - 4800 Watts 120V, 208V, 240V, and 277V @ 1Ø

Thermostat Range: 40 - 99 Degrees F Air Movement: 100 CFM
--

JOB NAME: _____
 LOCATION: _____
 ARCHITECT: _____
 ENGINEER: _____
 CONTRACTOR: _____
 SUBMITTED BY: _____
 DATE: _____

ITEM	QTY.	CATALOG NUMBER	TAG	WATTS	VOLTS	AMPS	BMS CONNECTION (Y/N)

**ACCESSORIES
AND
CONTROLS**

ITEM	QTY.	CATALOG NUMBER	TAG	DESCRIPTION

SUBMITTED BY:	DATE	APPROVED BY:	DATE

SSAR SERIES - DIGITAL FAN-FORCED ARCHITECTURAL WALL HEATERS



470 Beauty Spot Rd. E, Bennettsville, SC 29512



SELECTION CHART

CATALOG NUMBER	VOLTS	WATTS	AMPS	BTUHR
SSAR1802	120	540 - 1800	4.5 - 15.0	6,142
SSAR4808	208	1800 - 4800	8.7 - 23.1	16,378
SSAR4804	240	1800 - 4800	7.5 - 20.0	16,378
SSAR4807	277	1800 - 4800	6.5 - 17.3	16,378

Note: Standard grille color is White
 Add AL (Aluminum) suffix to catalog number. Example: SSAR4808AL
 Allow two weeks delivery for models with special color.
 See Color Selection Chart for custom colors.

SELECTION CHART

CATALOG NUMBER	DESCRIPTION
HTWHSM	Surface Mounting Frame 16-1/4" W x 19-3/8" H x 3-7/8" D
HTWHS1	1" Semi-Recess Mounting Frame 16-1/4" W x 19-3/8" H x 1" D
HTWHS2	2" Semi-Recess Mounting Frame 16-1/4" W x 19-3/8" H x 2" D

Note: Standard grille color is White
 Add AL (Aluminum) suffix to catalog number. Example: SSAR4808AL
 Allow two weeks delivery for models with special color.
 See Color Selection Chart for custom colors.

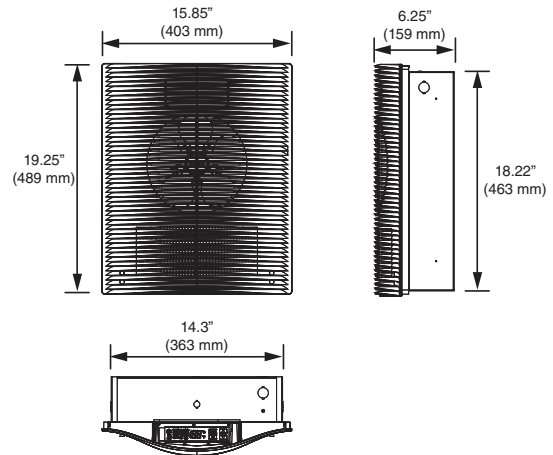

MOUNTING LIMITATIONS

Do not install heater closer than 12 inches to the floor, 12 inches to an adjacent wall, 36 inches to the ceiling. Do not install heater behind towel rack or door, upside down or sideways, in the floor, in the ceiling, or in closets.

Architect's and Engineer's Specifications

The electric fan-forced architectural wall heater shall be as manufactured by QMark, A Marley Engineered Products Brand, Bennettsville, SC. Heaters shall be certified by ETL to standard for heating equipment and meet UL standard 2021. All capacities, voltages, physical sizes, grille arrangements and options shall be specified in the heater schedule. The heater shall be designed for wall recess or surface mounting.

Heater Assembly: The heater assembly which fits into the back box shall consist of an 0.120" thick, powder coated aluminum die cast part fan panel / panel grille which are mounted all of the operational parts of the heater. The front grille shall be of the louvered type finished in polyester powder coating which resists fading and abrasion.

Heating Elements: The heating elements shall be warranted for five years and shall be of non-glowing design consisting of 80-20 Ni/Cr resistance wire enclosed in a steel sheath to which steel plate fins are brazed. The heating element shall cover the entire air discharge area to ensure uniform heating of all discharge air.

Thermal Limit: The heater shall be equipped with a manual-reset safety limit control that will automatically shut off heater in event of overheating due to any cause. The safety cutouts shall directly interrupt power to the elements. A red warning light will illuminate (visible at top of heater grille) to alert that this control has been activated.

Fan and Motor Assembly: The motor and fan assembly shall be direct drive and mounted on rigid heavy gauge brackets for quiet operation. The fan shall be five-bladed aluminum. The fan motor shall be totally enclosed.

Fan Delay Control: Fan control shall delay fan startup of the fan motor until the heating elements have warmed up. It shall maintain motor operation after heating elements have been de-energized to dissipate residual heat build-up.

Temperature Control: The unit is designed to be controlled electronically with a built-in electronic digital LCD touch screen display mounted on the grille and control board mounted on the fan panel. This control will maintain room temperatures within 1-1/2 degrees of set point. The output of heat is proportionally controlled as to how much heat is needed to satisfy the set point. Heater automatically adjusts wattage output for optimum comfort. Heater settings can be locked out for security purposes.

Disconnect Switch: This ON/OFF switch shall be mounted on the fan deck to disconnect single point connection to power supply for the internal electrical components, including the heating element. It will be completely concealed behind the front grille panel.

Building Management Connection: The unit shall include a unique built-in Building Management System (BMS) connection. This allows the building management system to connect directly to the heater using a dry contact switch (no voltage) to control the heater. A BMS icon is illuminated and all other icons are turned OFF and all buttons are disabled.