

Designed to handle clean, dry air up to a maximum of 180° Fahrenheit. Ideally suited for removal of fumes in paint spray booths, smoke removal from welding operations or supply air for air make-up systems.

FEATURES

- Spark resistant, heavy duty cast aluminum propellers
- Adjustable motor base allows for proper belt tension for maximum belt life
- Pulleys are rugged cast iron or turned steel

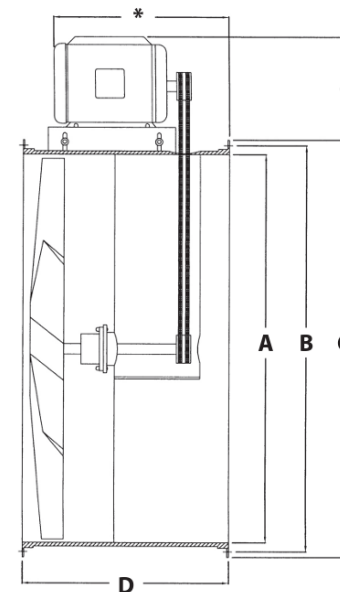
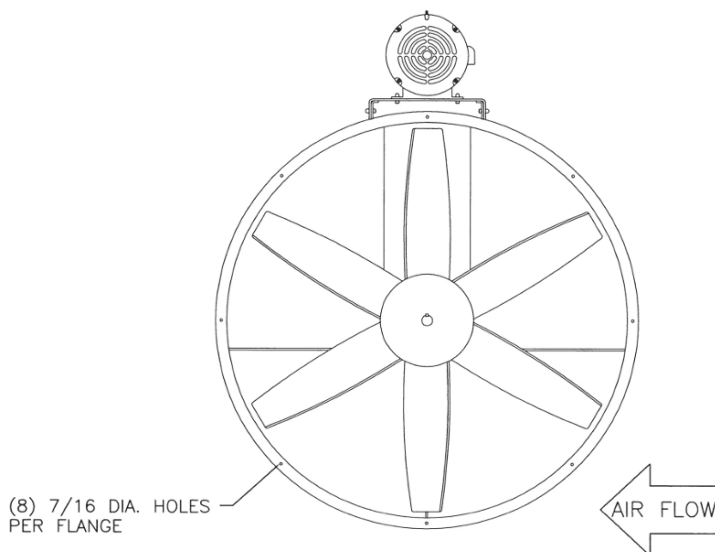

* Dimensions vary with motor

DIMENSIONS

Model	A	B	C	D	HP
NB12	12"	13-1/8"	14"	12"	1/4 to 3/4
NB15	15"	16-1/8"	17"	12"	1/4 to 3/4
NB18	18"	19-1/8"	20"	12"	1/4 to 1-1/2
NB24	24"	25-3/4"	27"	12"	1/2 to 1
NB24	24"	25-3/4"	27"	16"	1 to 3
NB27	27"	28-3/4"	30"	16"	3/4 to 2
NB30	30"	31-3/4"	33"	16"	1/2 to 5
NB34	34"	35-3/4"	37"	16"	1-1/2 to 5
NB36	36"	37-7/8"	39"	18"	3 to 5
NB42	42"	43-9/16"	45"	18"	1-1/2 to 5

OPTIONAL ACCESSORIES

- Belt guard
- Combination motor cover/belt guard
- Companion flanges
- Horizontal support legs
- Horizontal or vertical support brackets
- Inlet or outlet guards - OSHA compliant
- Inspection door

PERFORMANCE DATA

Blade Diameter	Model	Horse Power	RPM	Free Air	1/8" SP	1/4" SP	3/8" SP	1/2" SP	3/4" SP	1" SP	1-1/4" SP
12"	NB12-A	1/4	2625	1444	1307	1033	638	380	-	-	-
	NB12-B	1/3	2875	1586	1436	1135	700	415	-	-	-
	NB12-C	1/2	3450	1875	1650	1400	1320	1250	1100	660	-
	NB12-D	3/4	3450	2044	1960	1920	1820	1650	1500	1100	-
15"	NB15-A	1/4	2000	2600	2100	1700	-	-	-	-	-
	NB15-B	1/3	2200	2950	2500	2100	1760	1000	-	-	-
	NB15-C	1/2	1890	3350	3000	2650	2200	1500	-	-	-
	NB15-D	3/4	2200	3900	3700	3400	3100	2700	1150	-	-
18"	NB18-A	1/4	1600	3050	2500	2000	1200	-	-	-	-
	NB18-B	1/3	1725	3375	3000	2600	2000	1400	-	-	-
	NB18-C	1/2	1890	3850	3500	3100	2500	2000	-	-	-
	NB18-E	1	1725	4600	4375	4080	3600	3000	2100	1550	-
18"	NB18-F	1-1/2	1990	5350	5060	4830	4550	3950	3000	2500	-
	NB24-C	1/2	1298	5643	5320	4826	4440	3500	-	-	-
24"	NB24-D	3/4	1600	6906	6510	5900	5440	4650	2750	-	-
	NB24-E	1	1725	7425	7000	6350	5850	5000	3300	1775	-
	NBP24-E	1	1357	7450	7100	6650	5950	5200	3000	-	-
	NBP24-F	1-1/2	1540	8200	7900	7650	7280	6850	5500	-	-
	NBP24-G	2	1680	9600	9250	8940	8655	8250	7300	4800	-
	NB24-G	2	1600	9760	9114	8830	8460	8090	7000	4400	-
	NB24-H	3	1725	10500	9800	9500	9100	8700	7800	5000	3600
	NBP27-D	3/4	1250	8330	7814	7550	7070	6500	4650	-	-
27"	NBP27-E	1	1400	9400	8675	8480	7950	7300	5200	-	-
	NBP27-F	1-1/2	1600	10700	10250	9700	9080	8375	6000	2500	-
	NBP27-G	2	1350	11500	11200	10700	10000	9300	8000	5200	-
	NB30-C	1/2	1300	8900	7925	6660	4270	2300	-	-	-
30"	NB30-E	1	1298	9897	8970	7980	6050	4120	-	-	-
	NBP30-F	1-1/2	1035	11100	10600	9700	8600	7500	3500	-	-
	NBP30-G	2	1176	12100	11660	11000	10121	9322	6700	-	-
	NB30-H	3	1350	13480	12982	12498	12042	11465	10380	9470	7500
	NB30-I	5	1650	16440	15832	15242	14686	13982	12659	11550	9200
34"	NB34-F	1-1/2	1170	13695	12400	11100	8365	6000	1015	-	-
	NB34-G	2	1027	14657	13652	12590	11500	10000	8000	-	-
	NB34-H	3	1175	17580	16750	15896	14600	14095	12000	9500	-
	NB34-I	5	1416	20500	19800	19000	18325	17500	16000	14200	12250
36"	NBP36-H	3	930	17500	16800	15900	14740	14100	12200	-	-
	NBP36-I	5	1100	20600	19950	19200	18500	17800	16020	14300	-
42"	NBP42-F	1-1/2	750	18960	17000	14662	11700	7200	-	-	-
	NBP42-G	2	820	20700	18900	17002	14700	11400	4000	-	-
	NBP42-H	3	890	23700	22100	20200	18960	16970	9950	3600	-
	NBP42-I	5	850	26900	25600	24403	23450	22250	18400	13900	-

MODEL NUMBER SCHEMATIC

