

1' X 2" BIRD SCREEN ON
INTAKE AND DISCHARGE SIDES

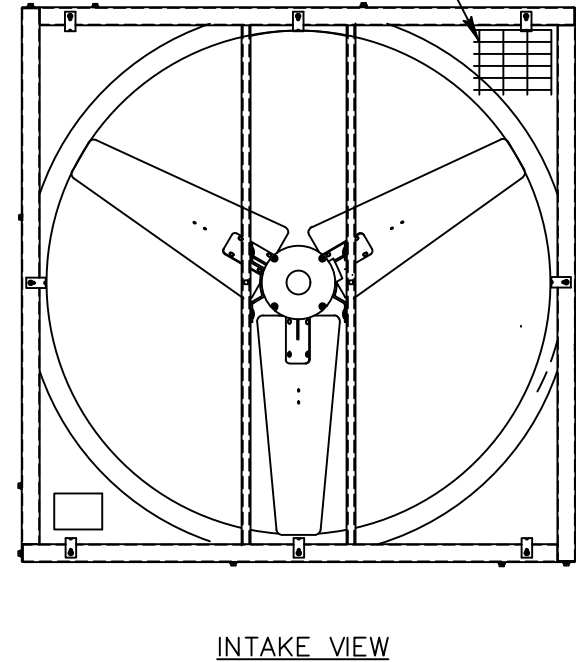

Fan Specifications

Blade Diameter:	48"	Motor Enclosure:	TEAO
Drive:	Direct	Duty Cycle:	Continuous Duty
Horsepower:	1	Guards:	1"X2" Bird Screen
Voltage:	230/460	Power Cord:	N/A
Phase:	3		
RPM:	820		

*See TriangleFans.com for performance specifications
*Specifications are subject to change without notice



PFG4815D-460

NOT TO SCALE | 25 SEP 2017