

Wall Exhaust Fans

MODEL N600/N700 – COMMERCIAL DUTY EXHAUST FAN – BELT DRIVE

APPLICATION

Economical fans for light duty general exhaust requirements. Well suited for factory or warehouse ventilation.

FEATURES AND BENEFITS

- Heavy duty 4-blade fabricated steel propellers standard.
- Sealed pillow block ball bearings.
- Fans shipped fully assembled and factory tested; ready for field installation.
- Motors are high quality industrial grade available in single or three phase - totally enclosed fan cooled.
- Belt driven for quiet operation.
- Suitable for intake or exhaust air flow.

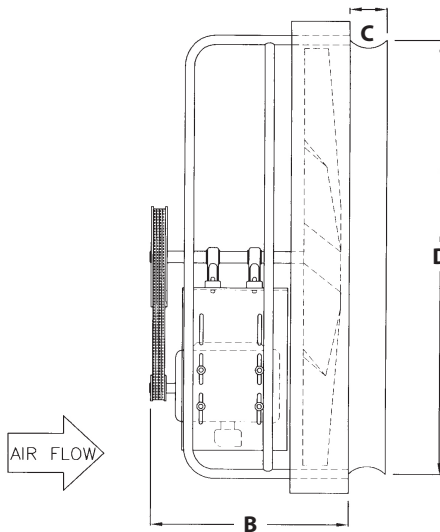
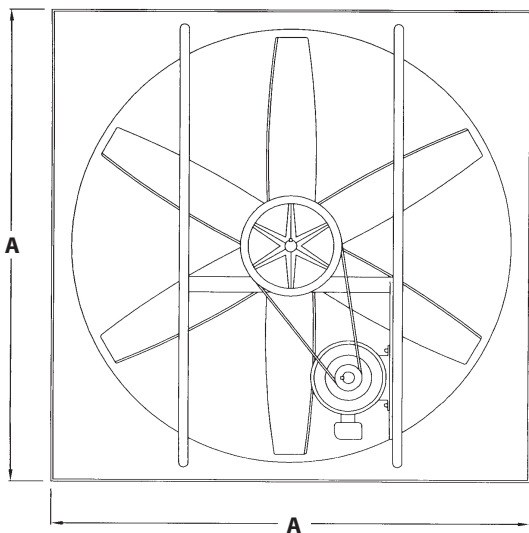

*Fan shown in exhaust configuration.

OPTIONAL ACCESSORIES

- Fan & shutter mounting box
- Front & rear OSHA compliant guards
- All aluminum gravity exhaust shutter
- Weatherhood with birdscreen

DIMENSIONS **subject to change without notice*

MODEL	A	B	C	D	HP
N624	30"	18"	3 1/2"	25 1/2"	1/3-1
N630	36"	18"	3 1/2"	31 1/2"	1/3-1
N636	42"	20"	4"	37 1/2"	1/3-1
N642	48"	20"	4 1/4"	44"	3/4-1 1/2
N648	54"	22"	4 1/2"	50 1/2"	3/4-1 1/2

MODEL	A	B	C	D	HP
N736	42"	20"	4"	37 1/2"	1 1/2-2
N742	48"	20"	4 1/4"	44"	2-3
N748	54"	22"	4 1/2"	50 1/2"	2-5
N760	66"	28"	5"	62"	2-5



MODEL N600/N700 – COMMERCIAL DUTY EXHAUST FAN – BELT DRIVE

PERFORMANCE DATA

Blade Dia.	Model	HP	RPM	Free Air	CAPACITY C.F.M.			
					1/8" SP	1/4" SP	1/2" SP	3/4" SP
24"	N624-B	1/3	825	5300	4700	3800	2200	1400
	N624-C	1/2	925	6200	5700	5000	4000	2600
	N624-D	3/4	1050	7000	6600	6000	4400	3000
	N624-E	1	1175	7800	7400	6900	5700	3500
30"	N630-B	1/3	570	7500	6000	3400	700	-
	N630-C	1/2	625	8500	7100	4400	2700	1300
	N630-D	3/4	725	10000	9100	7600	5100	1800
	N630-E	1	825	11000	10400	9300	5500	2800
36"	N636-B	1/3	425	9000	6800	3500	500	-
	N636-C	1/2	500	10500	8800	5900	3600	2000
	N636-D	3/4	575	11900	10500	8500	5500	4000
	N636-E	1	650	13100	11800	10200	6900	5000
	N736-F	1 1/2	750	15000	13500	12500	8500	5500
	N736-G	2	830	16500	15500	14500	11000	7000
42"	N642-D	3/4	430	14000	11500	7600	4800	3300
	N642-E	1	490	15400	13100	10400	6400	4600
	N642-F	1 1/2	550	17200	15300	12400	7900	5300
	N742-G	2	620	19400	17500	15600	9700	6000
	N742-H	3	700	22000	20500	19000	15000	8000
48"	N648-D	3/4	350	17000	12000	7000	2000	-
	N648-E	1	400	19100	16000	10900	6400	4000
	N648-F	1 1/2	460	22000	19000	14000	10000	6000
	N748-G	2	520	24000	22000	18000	12000	7500
	N748-H	3	590	27500	25000	22500	16000	9000
	N748-I	5	660	30500	28500	26000	21000	13000
60"	N760-G	2	320	31000	26000	16000	7000	-
	N760-H	3	370	35000	31000	23000	11000	-
	N760-I	5	420	39000	35000	29000	18000	-

MODEL NUMBER SCHEMATIC

