

Excellent for use where filtered exhaust air is required. Efficiently supplies clean, filtered air for OEM machinery and equipment markets such as pressurizing electrical cabinets. Economical choice for small unducted paint spray booths.

FEATURES

- Available with TEFC or explosion proof motors
- Rugged, spark-resistant aluminum propellers
- Standard OSHA style propeller guard for 12" - 30" diameters
- Removable filter box section
- Disposable 2" filters are high capacity pleated type that meet MERV 8 rating

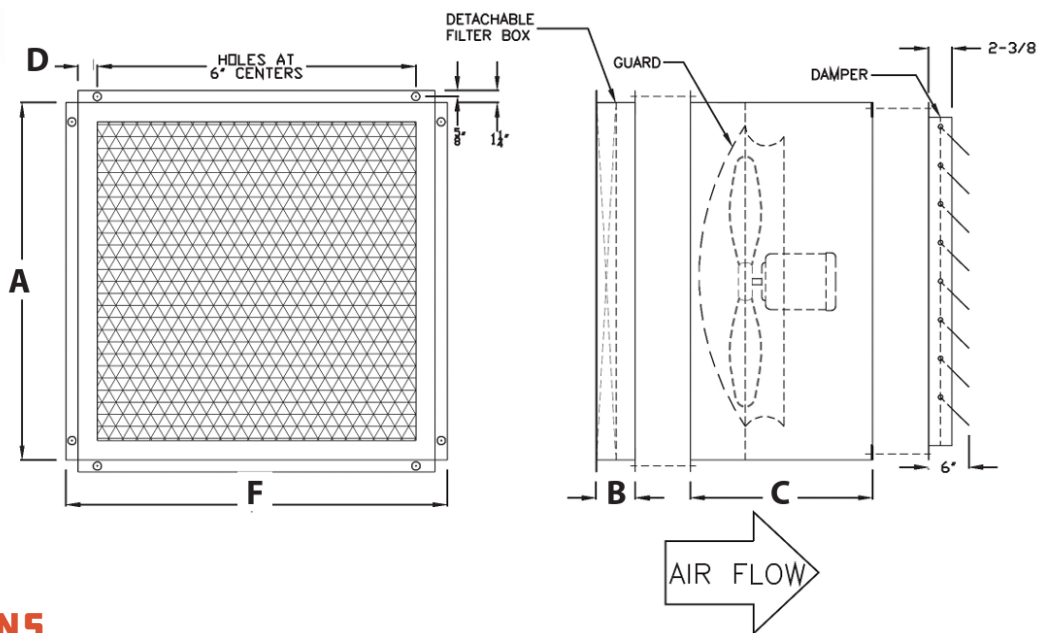

DIMENSIONS

Blade Diameter	Model	Horse Power	RPM	# of Filters	CFM w/ Filters
12"	NCFE12-A	1/4	1725	1	520
16"	NCFE16-A	1/4	1725	1	2000
18"	NCFE18-C	1/2	1725	1	3150
20"	NCFE20-E	1	1725	1	5900
24"	NCFE24-E	1	1725	4	6350
30"	NCFE30-C	1/2	1725	4	6300
36"	NCFE36-G	2	1140	8	13875
42"	NCFE42-G	2	1140	8	16000
48"	NCFE48-H	3	1140	12	18750

PERFORMANCE DATA

Blade Diameter	Model	Horse Power	RPM	# of Filters	CFM w/ Filters
12"	NCFE12-A	1/4	1725	1	520
16"	NCFE16-A	1/4	1725	1	2000
18"	NCFE18-C	1/2	1725	1	3150
20"	NCFE20-E	1	1725	1	5900
24"	NCFE24-E	1	1725	4	6350
30"	NCFE30-C	1/2	1725	4	6300
36"	NCFE36-G	2	1140	8	13875
42"	NCFE42-G	2	1140	8	16000
48"	NCFE48-H	3	1140	12	18750

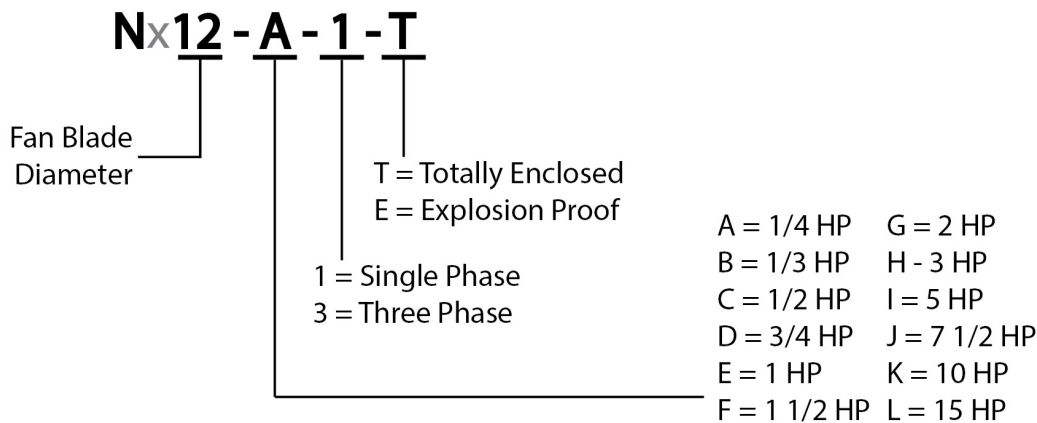
MODEL NUMBER SCHEMATIC

OPTIONAL ACCESSORIES

- Coatings available for harsh environments
- Standard OSHA style propeller guard for 36" - 48" diameters