

BALDOR® • RELIANCE 

Product Information Packet

AMERICRAFT MFG CO., INC.

M7009A

.75HP,3450RPM,3PH,60HZ,56,X3413M,XPFC,F1

Part Detail							
Revision:	AD	Status:	PRD/A	Change #:		Proprietary:	No
Type:	AC	Elec. Spec:	34WG5722	CD Diagram:	CD0007	Mfg Plant:	
Mech. Spec:	34-5323	Layout:	34LY5323	Poles:	02	Created Date:	
Base:	RG	Eff. Date:	01-03-2020	Leads:	12#18		

Specs			
Catalog Number:	M7009A	Insulation Class:	B
Enclosure:	XPFC	Inverter Code:	Not Inverter
Frame:	56	KVA Code:	K
Frame Material:	Steel	Lifting Lugs:	No Lifting Lugs
Output @ Frequency:	.750 HP @ 60 HZ	Locked Bearing Indicator:	No Locked Bearing
Synchronous Speed @ Frequency:	3600 RPM @ 60 HZ	Motor Lead Quantity/Wire Size:	12 @ 18 AWG
Voltage @ Frequency:	208.0 V @ 60 HZ	Motor Lead Exit:	Ko Box
	230.0 V @ 60 HZ	Motor Lead Termination:	Flying Leads
	460.0 V @ 60 HZ	Motor Type:	X3413M
XP Class and Group:	CLI GP D; CLII GP F,G	Mounting Arrangement:	F1
XP Division:	Division I	Power Factor:	73
Agency Approvals:	UR	Product Family:	Hazardous Location Motor
	UL	Pulley End Bearing Type:	Ball
	CSA	Pulley Face Code:	Standard
Auxillary Box:	No Auxillary Box	Pulley Shaft Indicator:	Standard
Auxillary Box Lead Termination:	None	Rodent Screen:	None
Base Indicator:	Rigid	RoHS Status:	ROHS COMPLIANT
Bearing Grease Type:	Polyrex EM (-20F +300F)	Shaft Extension Location:	Pulley End

Blower:	None	Shaft Ground Indicator:	No Shaft Grounding
Current @ Voltage:	1.300 A @ 460.0 V	Shaft Rotation:	Reversible
	2.600 A @ 230.0 V	Shaft Slinger Indicator:	No Slinger
	2.700 A @ 208.0 V	Speed Code:	Single Speed
Design Code:	B	Motor Standards:	NEMA
Drip Cover:	No Drip Cover	Starting Method:	Direct on line
Duty Rating:	CONT	Thermal Device - Bearing:	None
Electrically Isolated Bearing:	Not Electrically Isolated	Thermal Device - Winding:	None
Feedback Device:	NO FEEDBACK	Vibration Sensor Indicator:	No Vibration Sensor
Front Face Code:	Standard	Winding Thermal 1:	Automatic Thermal Overload
Front Shaft Indicator:	None	Winding Thermal 1 Location:	SB
Heater Indicator:	No Heater	Winding Thermal 2:	None
		XP Temp Code:	T3C

Nameplate NP0016XPSL										
NO.		CC								
SER. #										
SPEC	34-5323-5722									
CAT.NO.	M7009A									
H.P.	.75	T. CODE	T3C							
VOLTS	208-230/460									
AMPS	2.7-2.6/1.3									
R.P.M.	3450									
HZ	60	PH	3	CLASS	B					
SER.F.	1.00	DES	B	CODE	K					
RATING	40C AMB-CONT									
FRAME	56	NEMA NOM. EFF	75							
USABLE AT 208V	2.7	PF	73							
BLANK										

Parts List		
Part Number	Description	Quantity
SA008948	SA 34-5323-5722	1.000 EA
RA005395	RA 34-5323-5722	1.000 EA
TPMYJ68KX	THERMAL 3PH 0.75 AUT 120C	1.000 EA
MJ5000A09	EFI KIT #1578 (400 ML CARTRIDGE OF EFI	0.050 EA
35CB3001A01SP	EXPL CONDUIT BOX, MACH, 1/2" PIPE TAP LE	1.000 EA
11XW1032G06	10-32 X .38, TAPTITE II, HEX WSHR SLTD U	1.000 EA
HW3001B01	BRASS CUP WASHER, FOR #10 SCREW	1.000 EA
51XW0832A07	8-32 X .44, TAPTITE II, HEX WSHR SLTD SE	2.000 EA
34EP3703A01	FR ENDPLATE, MACH XP	1.000 EA
HW4002A02	1-11.5X2LG PIPE NIPPLE (F/S)	1.000 EA
HA1025A13	WSHR,FELT,.38" THICK F-26 CLASS	1.000 EA
HW3021E06	1/8 DIA X 5/8 ROLLPIN (F/S)	1.000 EA
HW5100A03	WAVY WASHER (W1543-017)	1.000 EA
34EP3704A01	PU ENDPLATE, MACH XP	1.000 EA
XY3118A12	5/16-18 HEX NUT DIRECTIONAL SERRATION	4.000 EA
34FN3002A01SP	EXTERNAL FAN, PLASTIC, .637/.639 HUB W/	1.000 EA
34FH4002A01SP	IEC FH NO GREASER PRIMED	1.000 EA
51XW1032A06	10-32 X .38, TAPTITE II, HEX WSHR SLTD S	3.000 EA
35CB3500A01SP	CONDUIT BOX LID, MACH	1.000 EA
51XN2520A16	SCREW, HEX WS SLT, ZN, 1/4-20 X 1.00	4.000 EA
HW2501D13	KEY, 3/16 SQ X 1.375	1.000 EA
HA7000A04	KEY RETAINER 0.625 DIA SHAFTS	1.000 EA
NP0018W	ALUM UL XP CONDUIT BOX NAMEPLATE	1.000 EA
HA6001A01	THERMAL RETAINER (PLATED)	1.000 EA

Parts List (continued)		
Part Number	Description	Quantity
NS2500A05	INSULATOR, AUTO THER PROT	1.000 EA
12XF0632A06	6-32X3/8 TY F HEX HD SLT	2.000 EA
MG1025G29	WILKOFASST, 789.229, DARK CHARCOAL GRAY	0.014 GA
85XU0407S04	4X1/4 U DRIVE PIN STAINLESS	6.000 EA
WD1000A16	2-520128-2 AMP FLAG TERMINAL(4M/RL)	12.000 EA
SP5037A01	TERMINAL PLATE ASS'Y MODEL 34 - 3 PHASE	1.000 EA
WD1000A16	2-520128-2 AMP FLAG TERMINAL(4M/RL)	12.000 EA
HA3104A05	THRUBOLT, 5/16-18 X 8.375	4.000 EA
MN416A01	TAG-INSTAL-MAINT no wire (1200/bx) 3/19	1.000 EA
LB1118	LABEL,WARNING (ROLL LABEL)	1.000 EA
LC0007	CONNECTION LABEL	1.000 EA
NP0016XPSL	SS XP UL CSA CC CL-I GP-D CL-II GP-F&G	1.000 EA
35PA1000	PKG GRP, PRINT PK1008A06	1.000 EA

AC Induction Motor Performance Data

Record # 6819 - Typical performance - not guaranteed values

Winding: 34WG5722-R001	Type: 3413M	Enclosure: XPFC
-------------------------------	--------------------	------------------------

Nameplate Data				460 V, 60 Hz: High Voltage Connection	
Rated Output (HP)	.75			Full Load Torque	1.2 LB-FT
Volts	208-230/460			Start Configuration	direct on line
Full Load Amps	2.7-2.6/1.3			Breakdown Torque	4.8 LB-FT
R.P.M.	3450			Pull-up Torque	3.5 LB-FT
Hz	60	Phase	3	Locked-rotor Torque	3.9 LB-FT
NEMA Design Code	B	KVA Code	K	Starting Current	7.6 A
Service Factor (S.F.)	1			No-load Current	0.85 A
NEMA Nom. Eff.	75	Power Factor	73	Line-line Res. @ 25°C	24.6 Ω
Rating - Duty	40C AMB-CONT			Temp. Rise @ Rated Load	64°C

Load Characteristics 460 V, 60 Hz, 0.75 HP

% of Rated Load	25	50	75	100	125	150
Power Factor	39	58	67	78	82	84
Efficiency	57.7	70.6	73.6	75.1	74.7	74
Speed	3553	3518	3481	3440	3395	3344
Line amperes	0.95	1.02	1.12	1.33	1.5	1.62

Performance Graph at 460V, 60Hz, 0.75HP Typical performance - Not guaranteed values

ABB Motors and Mechanical Inc.

WINDING # 34WG5722

Typical performance - not guaranteed values.

0.75 HP 3 PH 60 HZ 3450 RPM 460 V 3413M
 TORQUES(LB-FT): PO=4.8 PU=3.5 LR=3.9 LRA=7.6

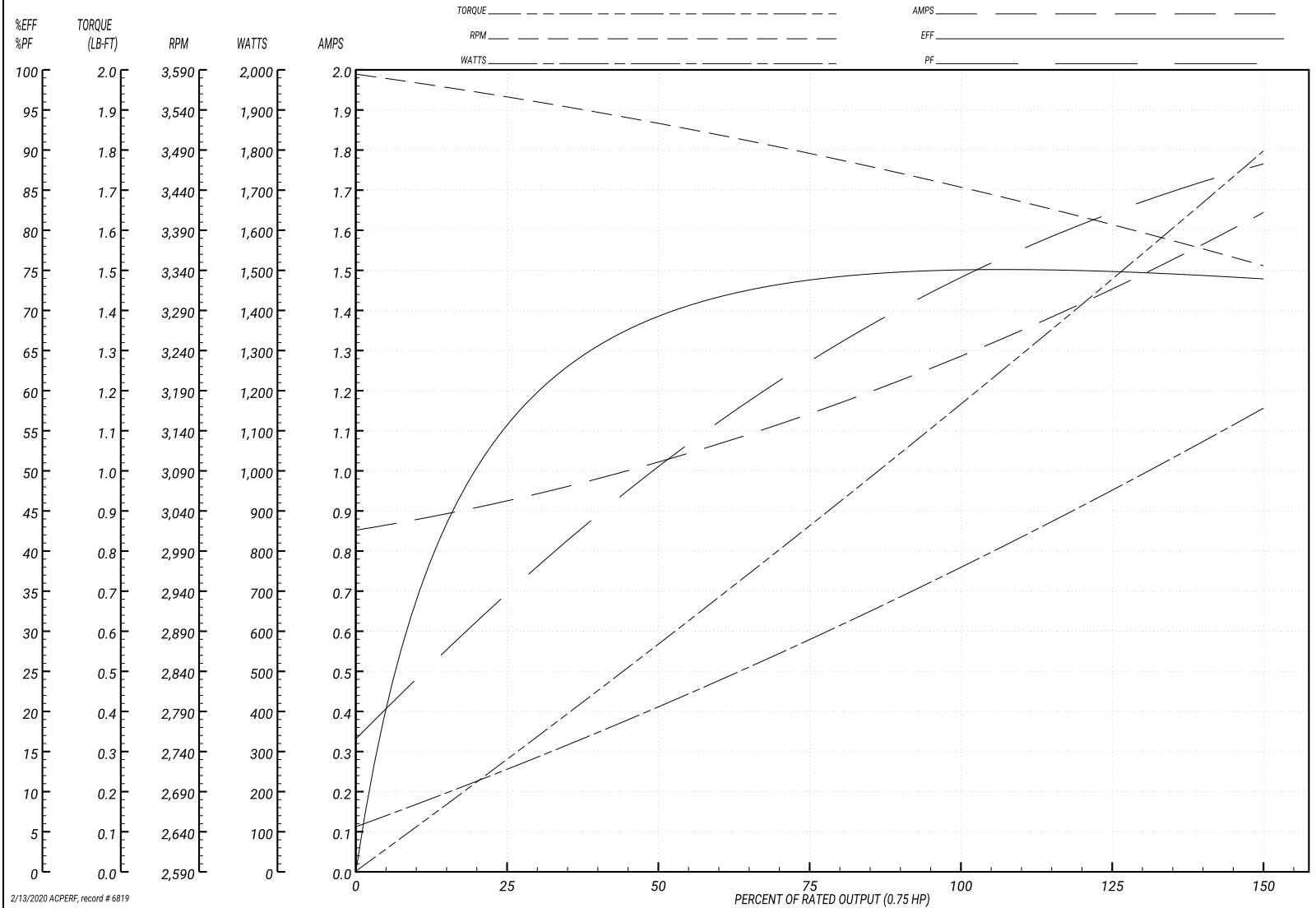

2/13/2020 ACPERF, record # 6819

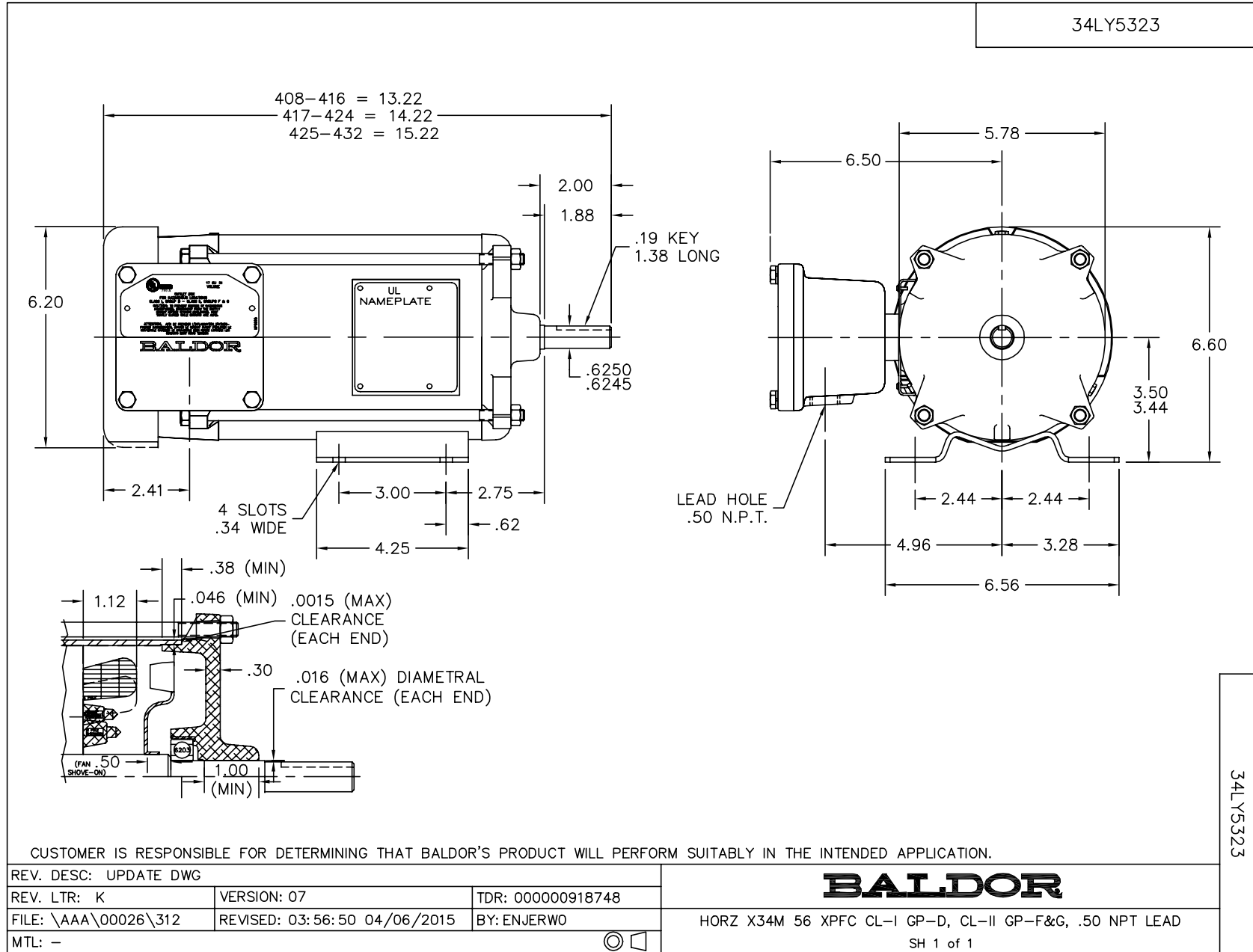

CD0007

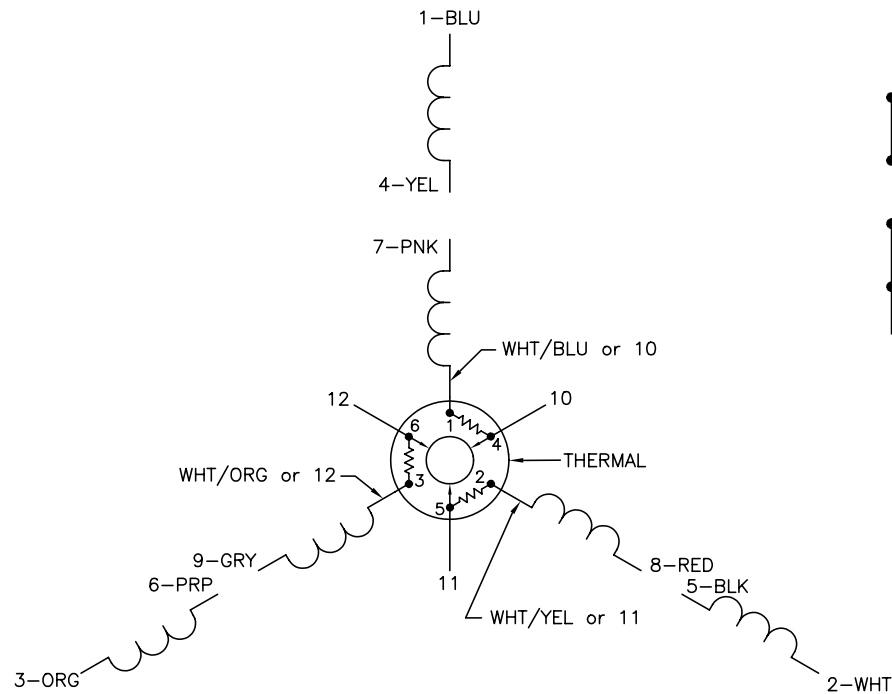

LOW VOLTAGE
(2Y)

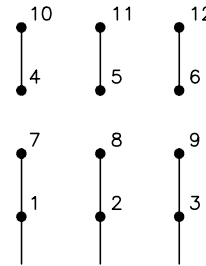

LINE

HIGH VOLTAGE
(1Y)

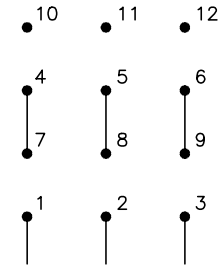

LINE

NOTES:

1. INTERCHANGE ANY TWO LINE LEADS TO REVERSE ROTATION.
2. ACTUAL NUMBER OF INTERNAL PARALLEL CIRCUITS MAY VARY.
3. LEAD COLORS ARE OPTIONAL. LEADS MUST ALWAYS BE NUMBERED AS SHOWN.

REV. DESC: ADDED "CK" PLANT CODE			
REV. LTR: E	BY: EAH	REVISED: 05/06/99 17:1	TDR: 0181040
L00000		FILE: AAA00008370	MDL: -
		MTL: -	

BALDOR ELECTRIC Co.

3PH, DV, THERMAL, 12 LEADS

CD0007