



MODEL PV

INLINE CENTRIFUGAL DUCT FAN



MODEL FEATURES

- Exhaust air up to 943 CFM with static pressure capabilities to 1.5" w.g.
- Galvanized steel casing with black baked enamel coating
- Pre-wired junction box
- Ideal for applications where space is limited
- Non-overloading backward inclined wheel for efficiency at higher static pressures
- AMCA Rated for Air Performance
- cULus Listed, Standard 507 & 705

MODEL OVERVIEW

The POWERVENT (PV) series of direct drive centrifugal in-line duct ventilation fans consists of twelve model sizes 4", 5", 6", 8", 10" and 12.4" respectively. All models are designed for direct connection in-line with standard diameter round ducting. Airflow performance values range from 152 CFM (PV-100X) up to 943 CFM (PV-315x).

All PV fan models incorporate a powerful external rotor motor that has been factory matched to a non-overloading backward curved centrifugal fan wheel.

This powerful combination enables the PV fans to deliver exceptional airflow performances against high static pressure typically found in ducted ventilation systems. All motors within PV fans are fully speed controllable using voltage or frequency control regulators.

The PV series of duct exhaust or supply fans have been specifically designed for simple installation and many years of maintenance free operation. The PV fans can be mounted at any angle and at any point along the duct. The totally enclosed motor design allows the PV fans to operate in high moisture, lint and dust laden air. All models are manufactured with high quality materials and workmanship that is supported by a comprehensive **five (5) year warranty**.

All PV Fans feature a corrosion resistant galvanized steel casing with black baked enamel coating and are supplied with a strong mounting bracket and pre-wired junction box.

The PV100X fans feature Class F motor insulation.



Model PV is available in our Quickship program. All sizes are available for next day shipping from stock.

5 year fan housing and motor warranty

CONSTRUCTION/SPECIFICATION CHECKLIST

Casing

- Manufactured from high grade pressed galvanized steel, with black baked enamel coating.
- Extra long inlet and discharge collars make installation quick and trouble free.
- Supplied with a strong galvanized steel mounting bracket.
- Supplied with a prewired junction box.

Wheel / Impeller

- Backward curved centrifugal type.
- Factory matched to an external rotor motor and dynamically balanced to eliminate vibration.

Long Life

- Permanently lubricated motors are engineered for trouble-free continuous operation for 40,000 hours.

Motor

- Totally enclosed permanent split capacitor start and run external rotor motors.
- 120V 60Hz (single phase) electrical connection.
- Permanently sealed, self lubricating precision ball bearings.
- Safety Thermal Overload Protection Cut-Out (Automatic Reset Type).
- All Models are suitable for working airstreams up to 140°F. PV-100X works up to 158°F.

Code Approval

- All models have been independently safety tested by Underwriters Laboratories, Inc. and are UL and cUL Listed.
- Independently safety tested by Intertek Laboratories, and are ETL Listed.
- Independently tested for Airflow Performance. The PV range is licensed to bear the AMCA seal for Air Performance.

ACCESSORIES



BOC
Interior
Air Valve



CAR
Backdraft
Damper



ACOP-VENT
Antivibrating
coupling



SIL
Sound
Attenuator



PER
Plastic louver
shutter



SC 15
Variable speed
control

Please refer to the S&P Group A (Residential/Light Commercial) catalog for a complete line of accessories.

PERFORMANCE/DIMENSIONS

Dimensions in inches/mm

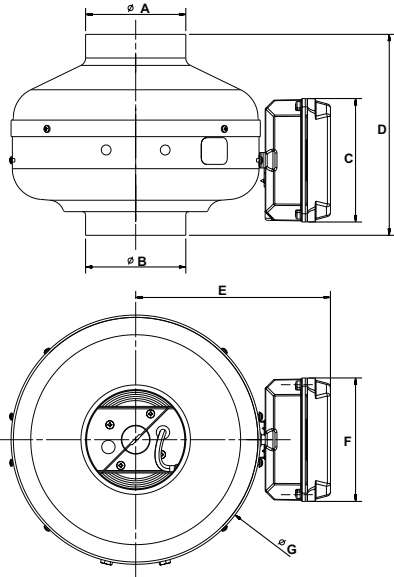

Model	A	B	C	D	E	F	G	Weight lbs(kgs)
PV-100x	3 ^{13/16} 97.5	3 ^{13/16} 97.5	4 ^{3/4} 120	7 ^{11/16} 196	7 ^{1/2} 190	4 ^{3/4} 120	9 ^{9/16} 243	7 3.0
PV-125x	4 ^{13/16} 122.5	4 ^{13/16} 122.5	4 ^{3/4} 120	7 ^{13/16} 198	7 ^{1/2} 190	4 ^{3/4} 120	9 ^{9/16} 243	7 3.0
PV-150x	5 ^{3/16} 147	5 ^{3/16} 147	4 ^{3/4} 120	8 ^{7/16} 214	9 ^{5/16} 236	4 ^{3/4} 120	13 ^{1/8} 334	11 5.0
PV-200x	7 ^{3/16} 198	7 ^{3/16} 198	4 ^{3/4} 120	8 ^{3/4} 223	9 ^{5/16} 236	4 ^{3/4} 120	13 ^{1/8} 334	11 5.0
PV-250x	9 ^{3/4} 248	9 ^{3/4} 248	4 ^{3/4} 120	8 ^{1/16} 205	9 ^{5/16} 236	4 ^{3/4} 120	13 ^{1/8} 334	13 6.0
PV-315	12 ^{5/16} 312	12 ^{5/16} 312	4 ^{3/4} 120	9 ^{3/16} 233	10 ^{9/16} 269	4 ^{3/4} 120	15 ^{13/16} 401	21 10.0
PV-315x	12 ^{5/16} 312	12 ^{5/16} 312	4 ^{3/4} 120	9 ^{3/16} 233	10 ^{9/16} 269	4 ^{3/4} 120	15 ^{13/16} 401	21 10.0

SPECIFICATIONS

Model	Nom.RP M	Volt	Max Watts	CFM V Static Pressure SP in W.G. (IN)									Max SP	MAX CFM	Duct Diameter (IN)
				0	0.125	0.25	0.375	0.5	0.75	1	1.25	1.5			
PV-100X	2880	115V	84W	153	142	130	120	111	96	80	63	34	1.85	153	4
PV-125X	2745	115V	85W	206	190	170	153	135	110	88	62	33	1.77	206	5
PV-150X	2750	115V	135W	390	367	340	312	285	233	193	153	110	2.05	390	6
PV-200X	2930	115V	180W	544	515	485	446	415	360	312	273	230	2.64	544	8
PV-250X	3045	115V	214W	618	595	570	540	509	450	390	340	297	2.8	618	10
PV-315	2920	115V	200W	669	640	610	581	552	489	427	368	309	2.21	669	12.4
PV-315X	2720	115V	365W	943	903	860	815	766	628	511	440	389	3.9	943	12.4

Performance certified is for installation type D-Ducted inlet, Ducted outlet. Performance ratings do not include the effects of appurtenances (accessories). Speed (RPM or RPS) shown is nominal. Performance is based on actual speed of test.



S&P USA Ventilation Systems, LLC., Div. of Soler & Palau Ventilation Group, certifies that the PV range shown herein is licensed to bear the AMCA Seal. The ratings shown are based on tests and procedures performed in accordance with AMCA Publication 211 and comply with the requirements of the AMCA Certified Ratings Program.



The PV-POWERVENT Series fans are California Title 24 compliant and meet ASHRAE 62.2 when installed with 3 way switch and remotely mounted speed control.

Sound

Fan sound levels are measured in sones. At this time there are no sone level test standards available through HVI due to the fact that remote mounted fan noise levels are in proportion to the following: type of duct, length of duct, fan distance from the intake source and other random factors. It is generally accepted that remote mounted venting is usually quieter than standard (in room) venting.



KIT - PV BATHROOM EXHAUST KITS

FEATURING PV-POWERVENT FANS

S&P PV-POWERVENT Series fans are also available as easy-to-install kits. This ultra powerful bathroom fan offers a choice of single or dual vent exhaust. These kits are used for installations that require long or complicated duct runs.



PV Deluxe Exhaust Kits



Standard Exhaust Kits



KIT-PV100x

- 1 PV100x exhaust fan
- 1 plastic round grille (PG-100)
- Mounting bracket

KIT-PV150X

- 1 PV150X exhaust fan
- 1 plastic round grille (PG-150)
- Mounting Bracket

KIT-PV100X-DV

- 1 PV100x exhaust fan
- 2 plastic round grilles (PG-100)
- 1 Y-fitting (SY-4)
- Mounting Bracket

KIT-PV150X-DV

- 1 PV150X exhaust fan
- 2 plastic round grilles (PG-150)
- 1 Y-fitting (SY-6)
- Mounting Bracket

KIT-PV200-DV

- 1 PV200 exhaust fan
- 2 plastic round grilles (BOR-200)
- 1 Y-fitting (SY-8)
- Mounting Bracket