

J&D Manufacturing

MAGNUM 58" EXHAUST FAN



WARRANTY

J&D Mfg. warrants this products is free from defects in materials and workmanship under normal use for the period of three years from date of purchase. Our warranty does not cover ordinary wear and tear. J&D Mfg can repair or replace at our option, any product or part of the product that is found to be defective. Our warranty applies to materials only and does not include return freight, delivery, loss or damage to personal property, cost of removal or installation, any incidental or consequential damages or labor. This warranty does not apply to products which are misused, abused, altered, improperly installed or subject to negligence. All warranties must be approved through our warranty department. The original purchaser must present a copy of the invoice for the defective product.

RECOMMENDED TOOLS FOR INSTALLATION AND ASSEMBLY (NOT PROVIDED)

- Safety Glasses
- Socket Wrench
- 1/2" Socket
- 1/4" Nut Driver
- 1/2" Wrench
- 3/8" Wrench
- Impact Driver
- Drill
- 1/8" Drill Bit
- 13/64" Drill Bit
- 10 ft-lb Torque Wrench
- 23 ft-lbs Torque Wrench
- Cutting Device (for Rubber Gasket)

INSTALLATION

Please read over ALL instructions carefully before you begin.

If you have any questions please call your local dealer, or contact J&D Manufacturing at 1-800-998-2398.

PARTS LEGEND

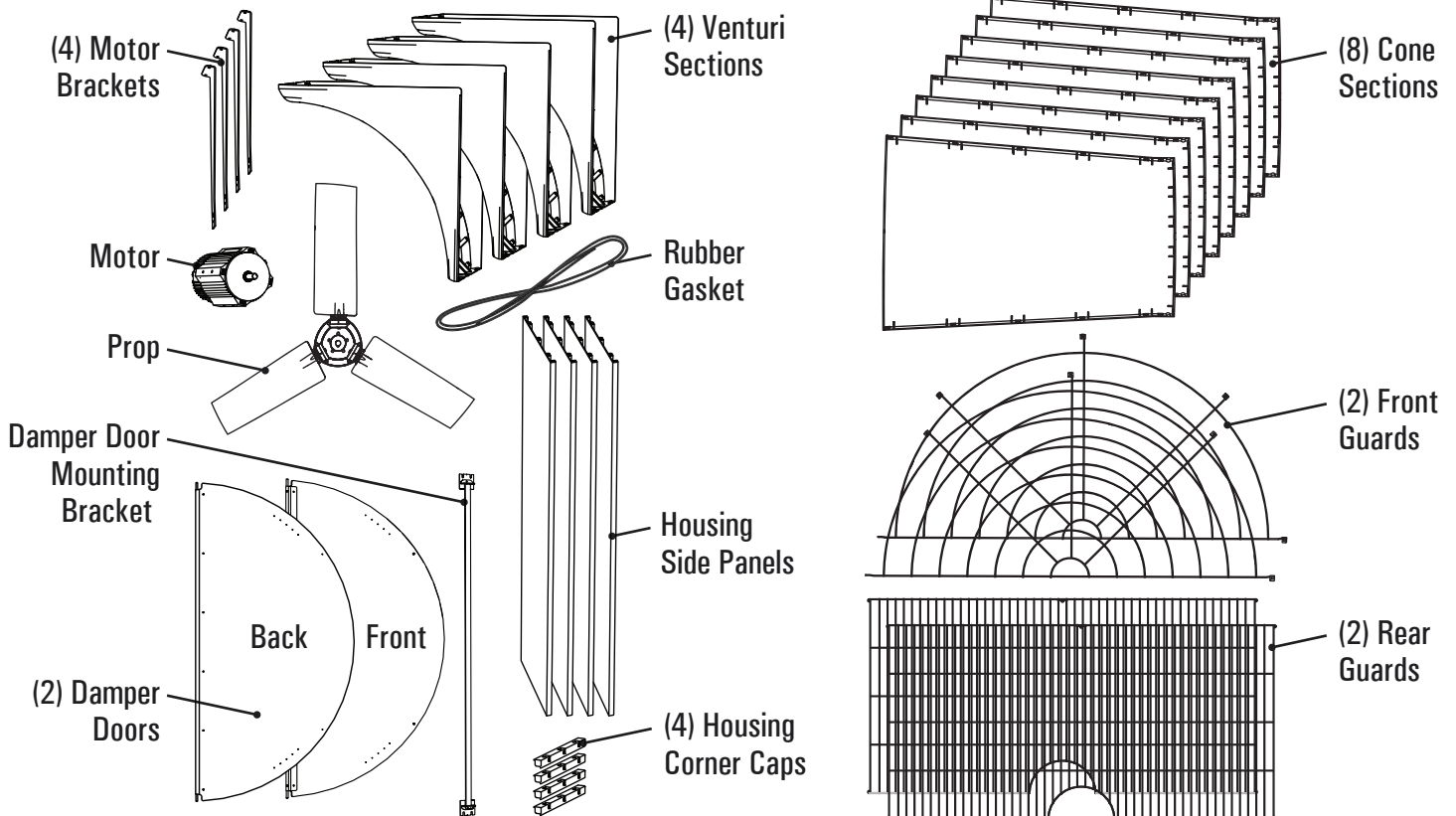

Bag 1 (Tools)

- #3 Phillips Bit
- 1/16" Hex Wrench

Bag 2 (Housing)

Bag 2 (Part 1)

- (28) 5/16"-18 x 7/8" Bolts

Bag 2 (Part 2)

- (28) 5/16"-18 Serrated Flange Nuts

Bag 2 (Part 3)

- (24) #14-10 x 2" Screws (Use #3 Phillips Bit from Bag 1)

Bag 3 (Motor)

- (8) 3/8"-16 x 3/4" Bolts
- (8) 3/8" Washers

Bag 4 (Damper Doors)

- (5) #4-40 x 3/4" Screw
- (5) #4-40 Lock Nuts

Bag 5 (Cone)

Bag 5 (Part 1)

- (50) #14-10 x 2" Screws (Use #3 Phillips Bit from Bag 1)

Bag 5 (Part 2)

- (50) 5/16"-18 x 7/8" Bolts

Bag 5 (Part 3)

- (50) 5/16"-18 Serrated Flange Nuts

Bag 6 (Cone Guard)

- (8) 5/16"-18 x 1" Bolts
- (8) 5/16"-18 Serrated Flange Nuts

Bag 7 (Mounting Screws)

- (4) #12-11 x 3 1/2" Screws (Use #3 Phillips Bit from Bag 1)

Bag 8 (Motor Guard)

- (10) #12-11 x 5/8" Screws (Use #3 Phillips Bit from Bag 1)

Bag 9 (Misc. Hardware)

- (2) SS Eyebolts
- (4) SS Serrated Flange Nuts #10-24
- (1) 1/4" x 2" Machine Key
- (4) SS Damper Door Striker Plates
- (4) Damper Door Magnets
- (4) 1/2" OD 1/8" ID Nylon Spacers
- (2) SS Damper Door Springs
- (1) Front Guard Plate Hub w/Hardware
- (4) 11" Cable Ties

Site Requirements:

- Rough Opening - 65 1/4" W x 65 1/4" H
- Side-By-Side Recommended OC Dimension - Minimum 75"

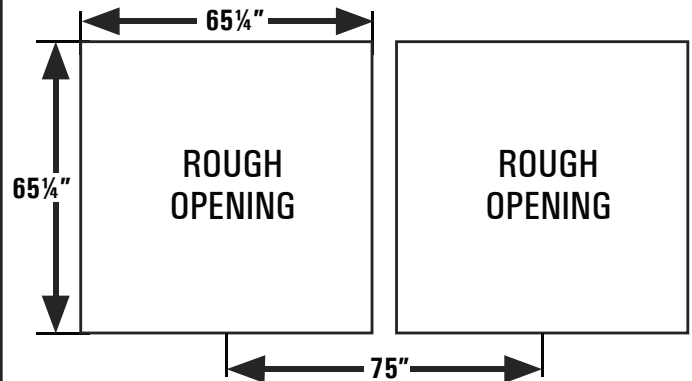

Venturi Assembly:

- Lay out the (4) venturi sections flat on the floor with the curve side of the sections facing up.
- Assemble the motor mount brackets (flat side down) in-between each venturi section.

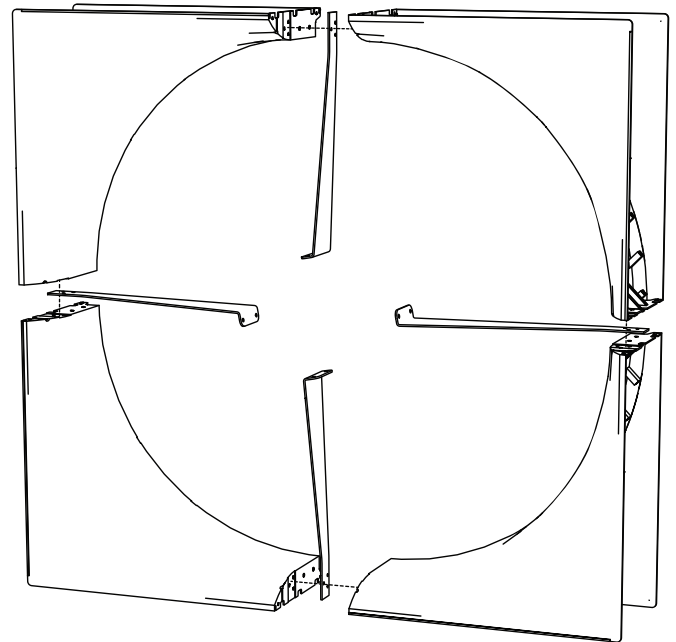

1

- Using (28) 5/16"-18 x 7/8" Bolts from Bag 2 (Part 1) and (28) 5/16"-18 Serrated Flange Nuts from Bag 2 (Part 2), assemble the motor mount brackets and venturi sections.

- Tighten only the bolts and nuts securing venturi sections.
- Holding the motor brackets up so the back side is flush to the outside of the venturi sections, tighten the bolts and nuts securing motor mounts and venturi sections.

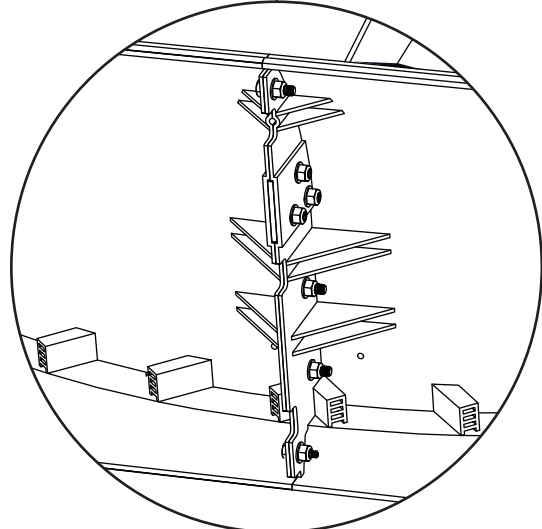
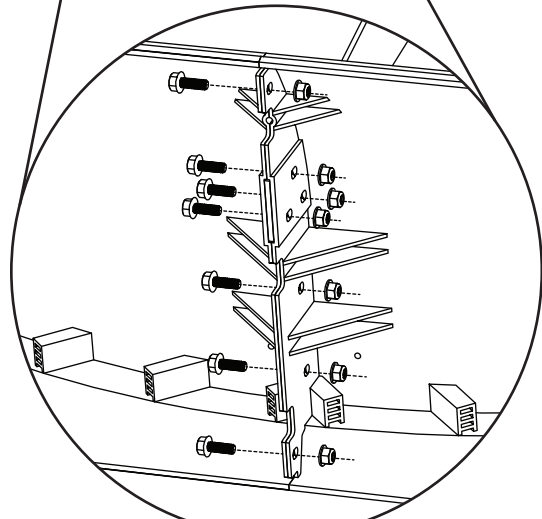
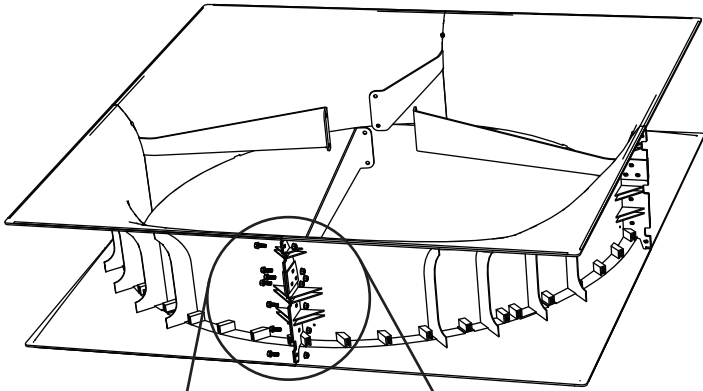

Eye Bolt Installation:

- Stand the housing assembly up.
- Locate the dimple marks on the exterior of the venturi next to the motor brackets.
- With a 13/64" drill bit drill out the (2) holes for the eyebolts.

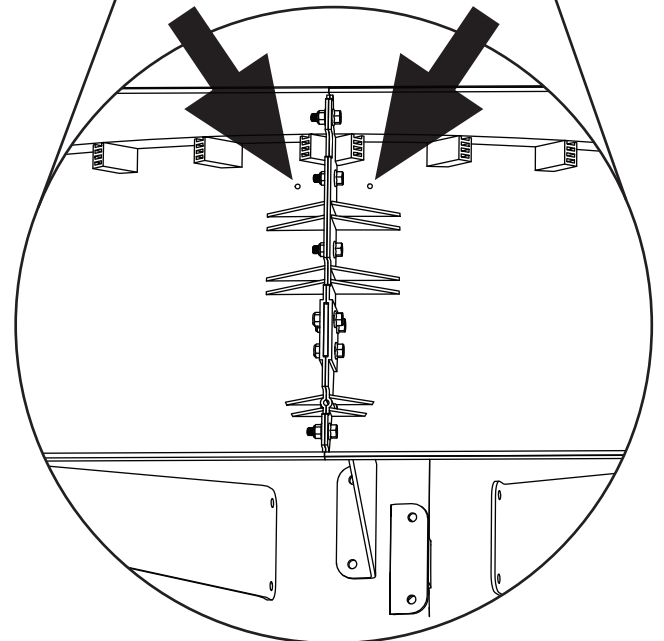
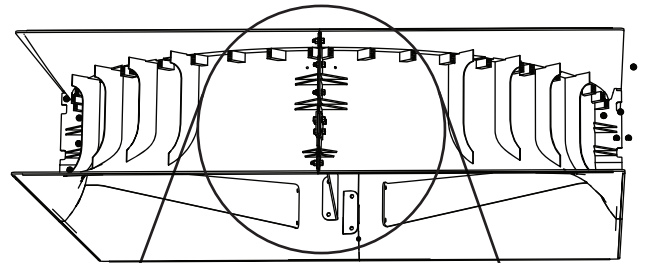
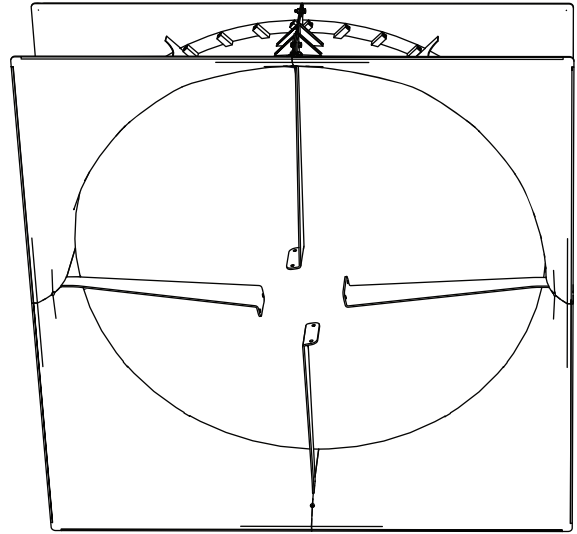

2

3

- Assemble (2) SS **Eyebolts** and (2) SS **Serrated Flange Nuts** #10-24 from **Bag 9 (Misc. Hardware)**
 - With the flange facing up thread (1) **Serrated Flange Nut** onto each **Eyebolt** as far as it will go.
- Insert each eyebolt nut assembly up through the hole drilled in **Step 3** and secure with a SS **Serrated Flange Nut** #10-24 from **Bag 9 (Misc. Hardware)**, flange facing down.
- Using 3/8" wrench tighten each eyebolt assemblies

NOTES:

- Turn the eyebolts so the opening of the loops are facing each other.
- Where the eyebolts are installed is now considered the TOP of the fan.

Location of eyebolts=Top of Fan

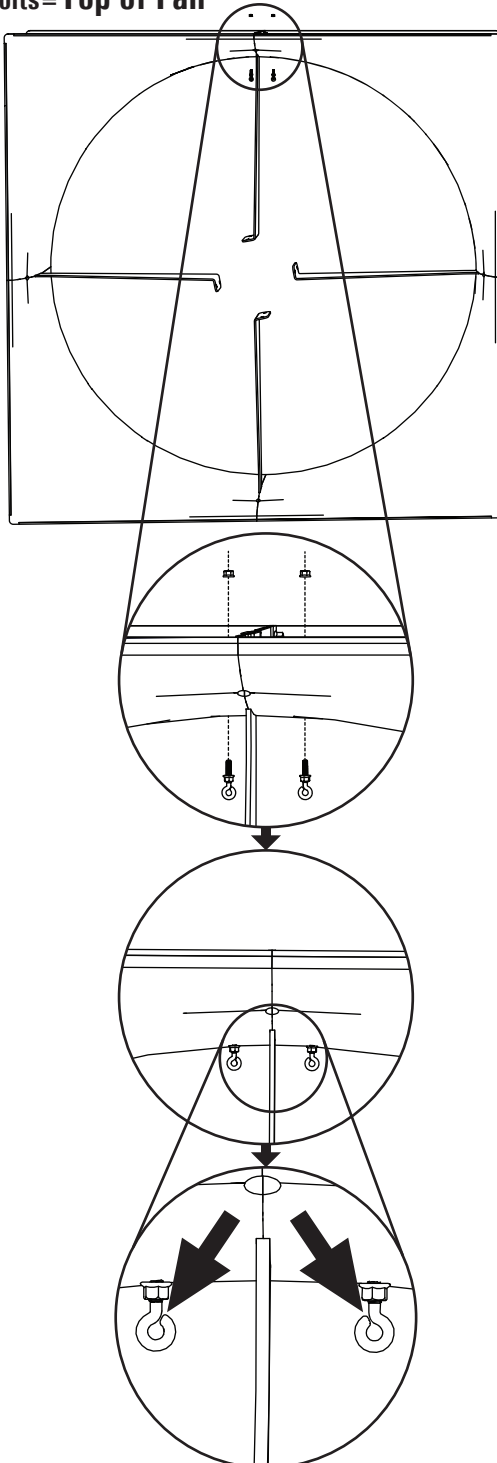

4

Housing Side Panel Assembly:

- Starting on a corner and with the front and back venturi section channels inserted into the grooves of the housing side panel.
- Slide the housing side panel across the top until it hits the center seam of the assembled venturi sections.
- Lift up on the center of the housing side panel and continue to slide housing side panel until it is centered.
- Repeat until all four sides have housing side panels installed

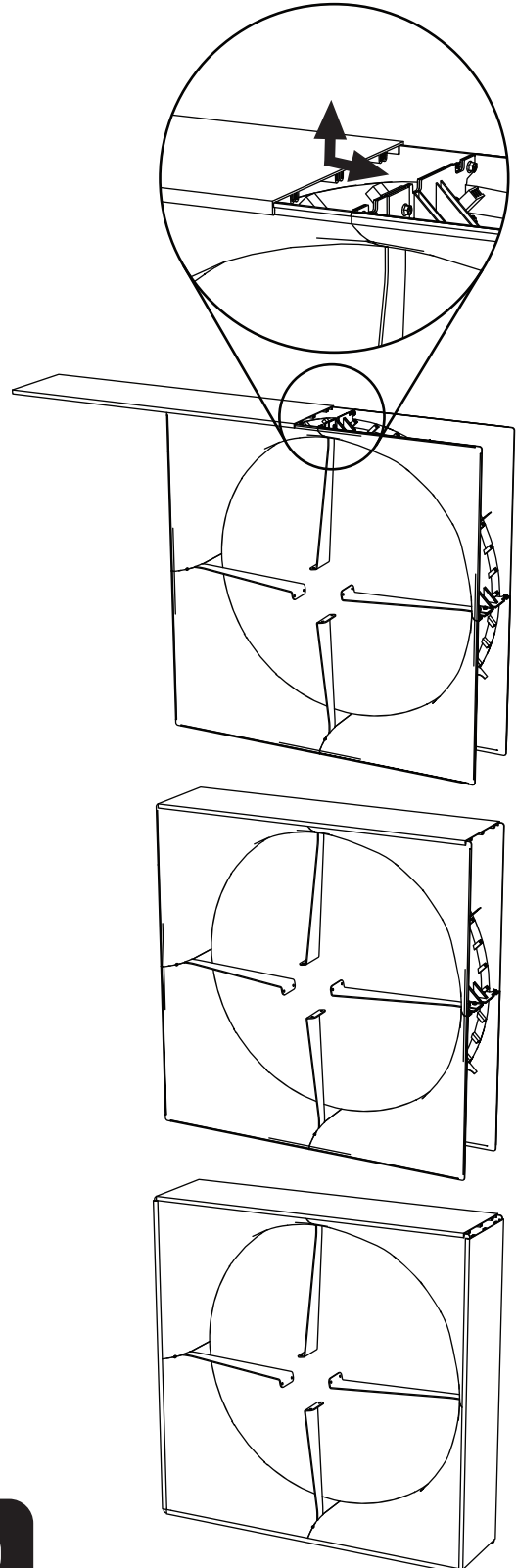

5

Installing Housing Corner Caps:

- Place a housing corner cap onto the housing between (2) housing side panels assembled in the previous step.
- Using the included **#3 Phillips Bit from Bag 1 (Tools)** and (6) **#14-10 x 2" Screws from Bag 2 (Part 3)**, screw the corner to the panels.

NOTE:

- The screws should draw the housing side panel up tight to the housing corner cap, but the housing side panel may need to be pushed/pulled as it is being screwed together.
- Repeat until all four housing corner caps have been installed

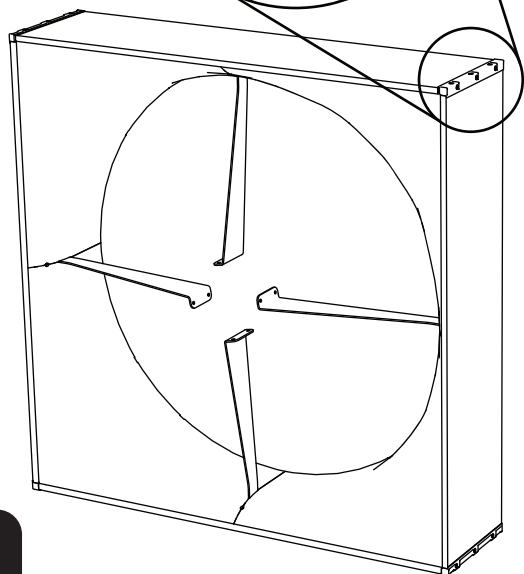
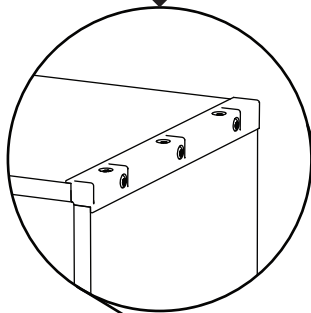
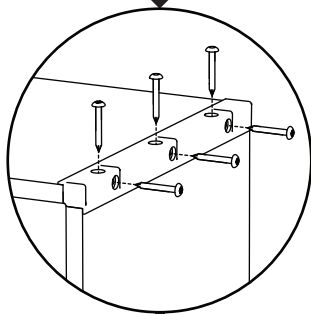
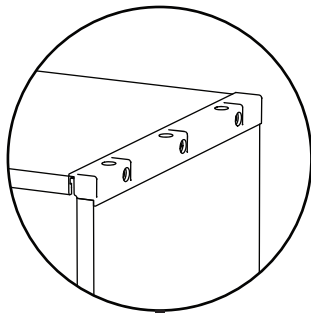

6

Motor Installation:

NOTE: 2 person lift is recommended for handling of 105lb motor

- Using the pallet the fan came on, place the motor in the center between the pallet slats with the shaft facing up.
- Place housing over motor with the housings eyebolts aligning with motor wiring ports as shown below.
- Use scrap wood 2x4's or other items to lay between the pallet and the fan housing to align motor brackets with motor and to support the housing.

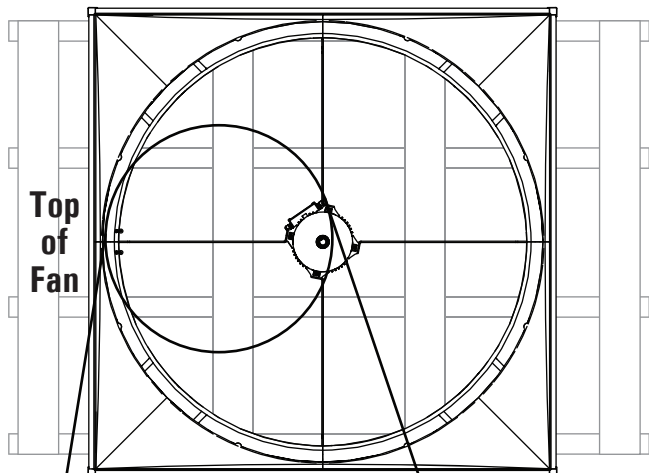
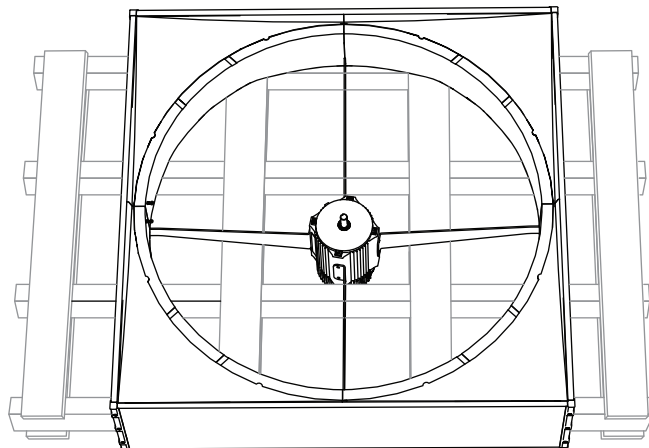

Top of Fan

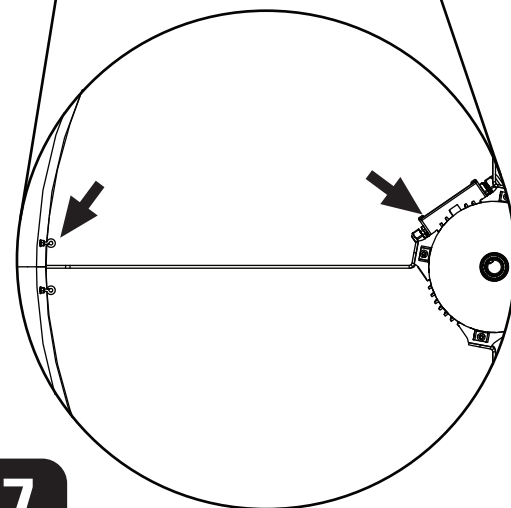

7

- Line up the holes of the motor mount brackets to the holes in the motor housing.
- Assemble the (8) 3/8"-16 x 3/4" **Bolts** and (8) 3/8" **Washers from Bag 3 (Motor)**
- Starting each bolt and washer assembly **by hand**, begin attaching motor to brackets - since motor has an aluminum housing **care must be taken to not cross-thread or strip-out the motor mounting threads**
- Once all motor mounting hardware has been hand started, torque the bolts to 23 ft-lbs using hand tools only

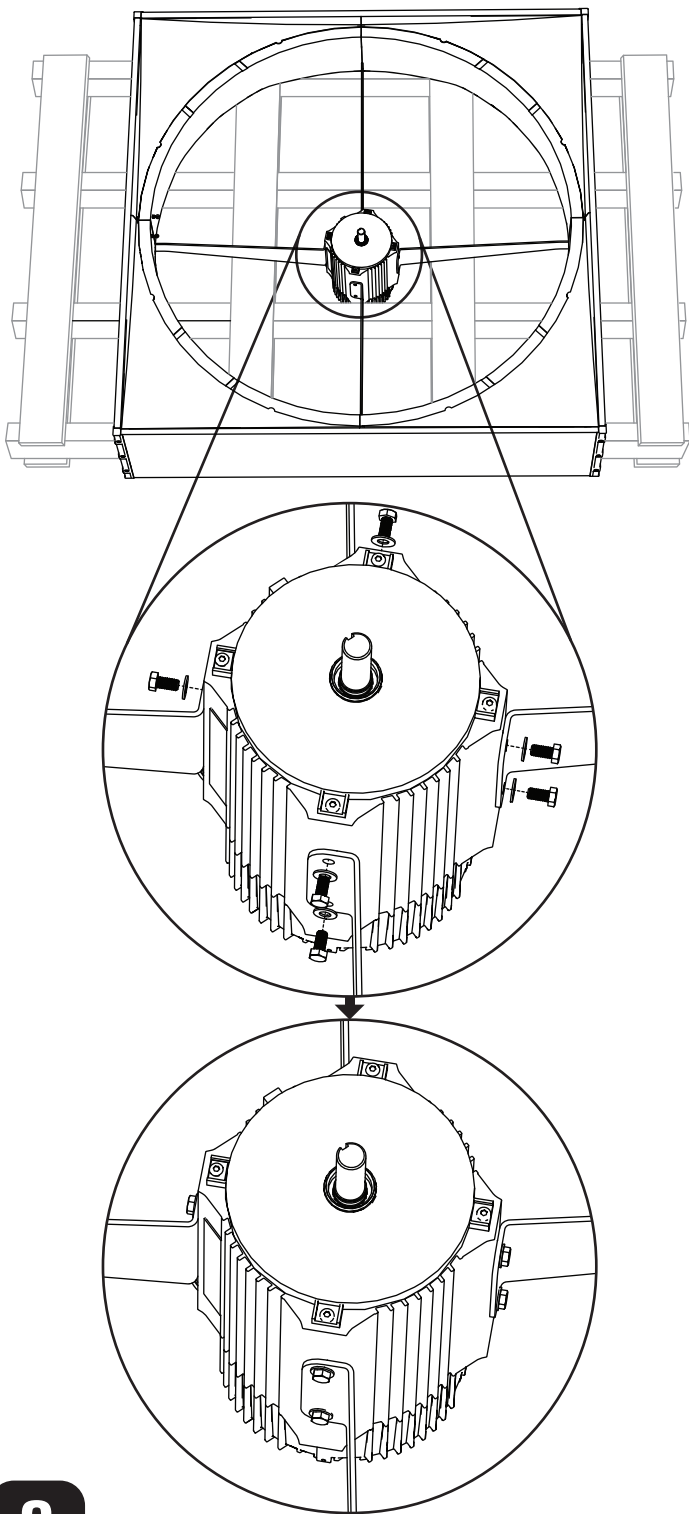

8

Prop Installation:

- Insert the 1/4" x 2" **Machine Key from Bag 9 (Misc. Hardware)** into the key notch on the motor shaft
- Slide prop onto the keyed motor shaft until flush with end of motor shaft.
- Secure prop by tightening the (2) set screws (located on underside of prop) to 10 ft-lbs
- Rotate the blade to make sure there is no interference.

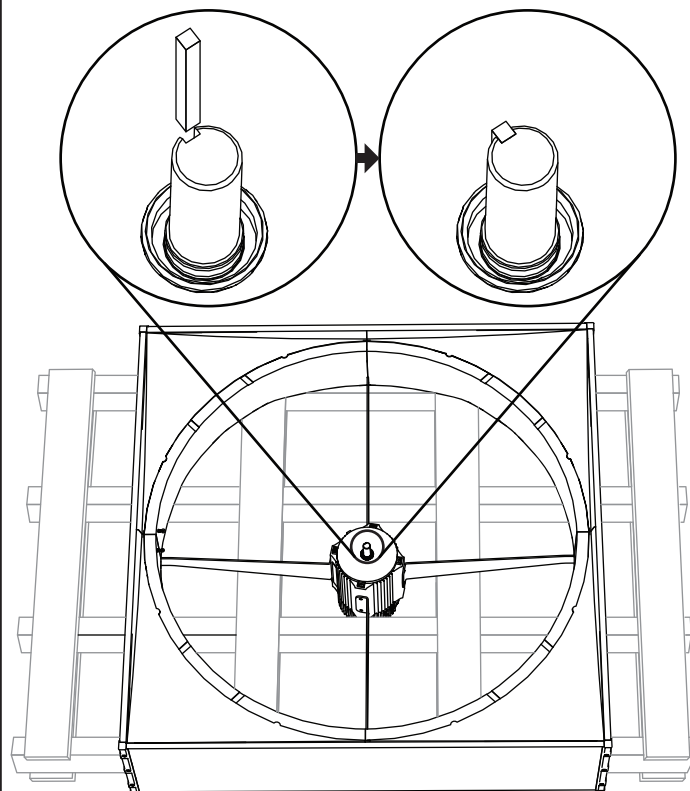

9

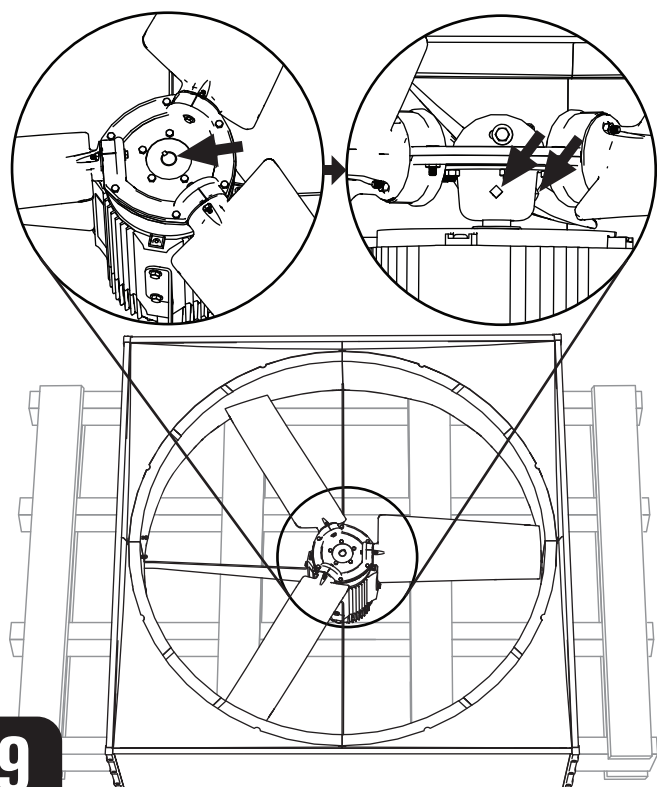

Damper Door Mounting Bracket Installation:

- Using the illustrations below identify the top and bottom of the damper door mounting bracket
- Arrange bracket so that the top of the bracket is matched to the top of the fan
- Using the center markers on the damper door mounting bracket align the bracket with the seams of the assembled venturi as shown below

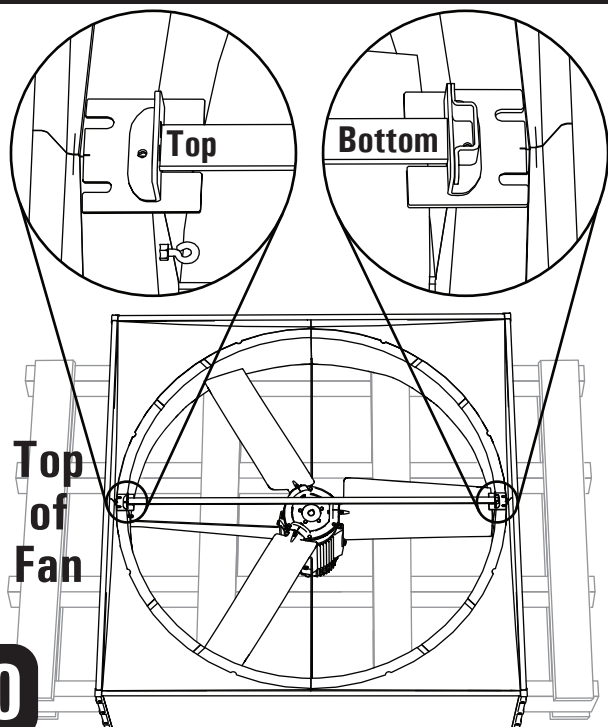

10

Damper Door Striker Plates Installation:

- On the edge of the housing venturi under the just placed rubber gasket locate the 4 striker plate grooves nearest the center of the fan venturi, (do not use the ones nearest the top or the bottom of the fan).
- Carefully lift off the rubber gasket over the striker plate groove and insert (1) SS Damper Door **Striker Plates from Bag 9 (Misc. Hardware)** at each location, angle the striker plate so the angle matches the fan housing. To secure the striker plates, press the rubber gasket back down.

NOTE: No hardware is used to secure striker plates at this time.

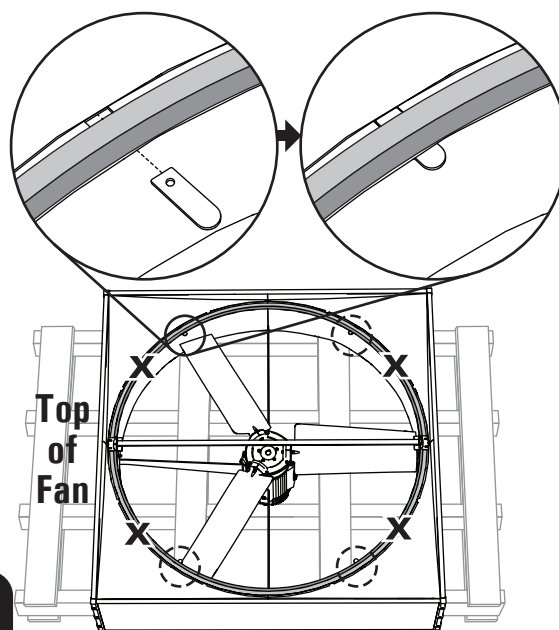

12

Rubber Gasket Installation:

- Starting on one side of the damper door mounting bracket peel the backing off the rubber gasket 1' at a time and with the raised portion to the center and flush to the interior of the venturi stick it to the housing.
- Continue to stick the gasket around the circumference until you come to the damper door mounting bracket, trim flush with end of bracket
- Repeat for other side of the housing opening.
- Go back and press down on the flat part of the gasket all the way around the housing to make sure it is stuck down.

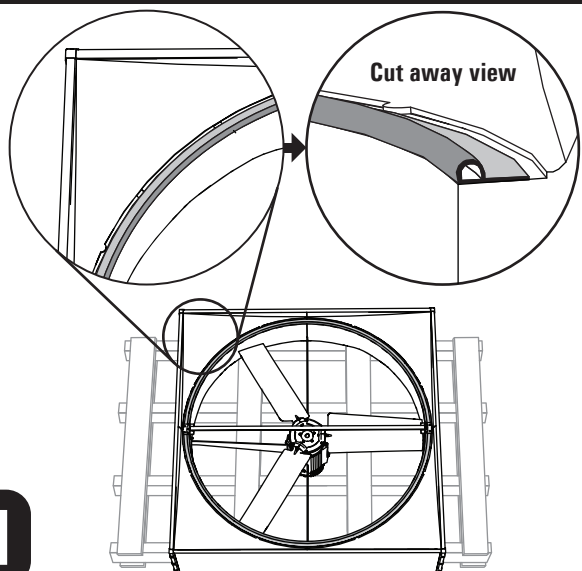

11

Attaching Magnets to Damper Door:

- Identify the back and front of the damper doors the magnet will be attached to the back of the damper doors
- Get (1) #4-40 x 3/4" **Screw from Bag 4 (Damper Doors)** and assemble (1) Damper Door **Magnet** then (1) 1/2" OD 1/8" ID **Nylon Spacer from Bag 9 (Misc. Hardware)** onto screw, insert through drilled hole and secure with (1) #4-40 **Lock Nuts from Bag 4 (Damper Doors)**, using 1/16" **Hex Wrench from Bag 1 (Tools)**. Repeat until all (4) Damper Door Magnets are installed.

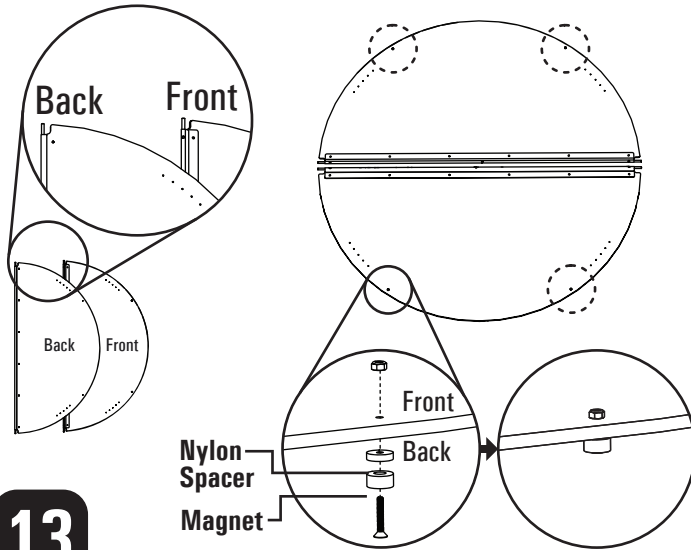

13

Installing Damper Door:

- Insert damper door rod fully into the top part of the damper door mounting bracket then slide damper door down so that the damper door rod end rests against the stop on the damper door mounting bracket as shown below.
- Repeat for second damper door

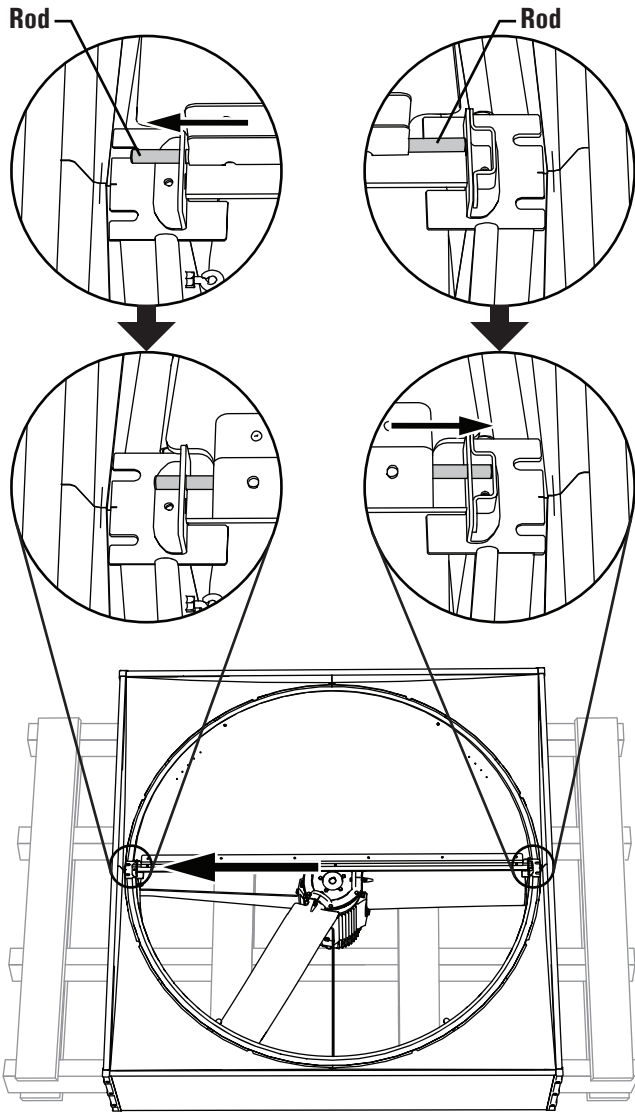

14

Cone Assembly:

- Lay out the (8) cone pieces, place the (2) sections with the J&D logo across from each other as shown below.
- Using (6) 5/16"-18 x 7/8" Bolts from Bag 5 (Part 2) and (6) 5/16"-18 Serrated Flange Nuts from Bag 5 (Part 3), assemble two cone pieces. Repeat until all (8) cone pieces are assembled.
- Using a 1/2" socket with impact driver and wrench tighten the cone pieces together.

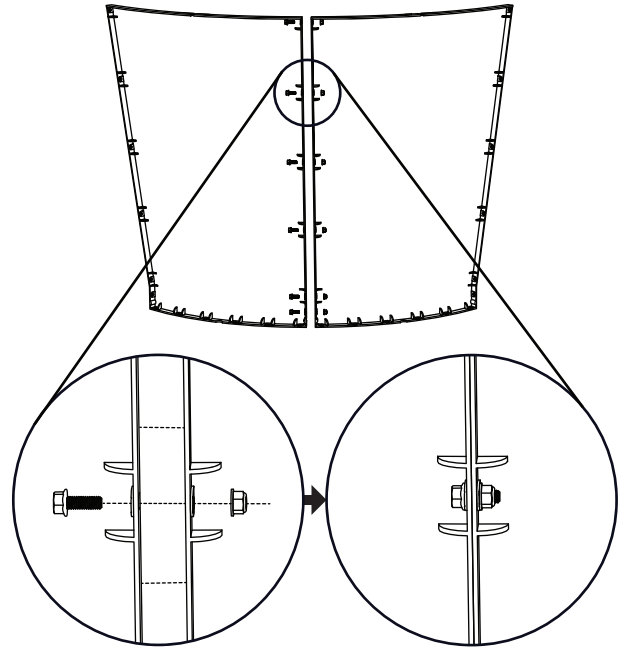
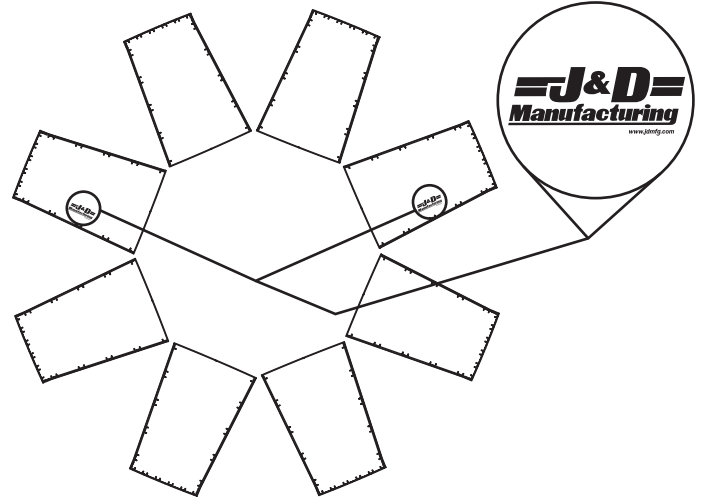

15

Cone Installation:

- Using (2) people lift the cone assembly onto the housing assembly.
 - With J&D logoed cone sections facing the sides (not the top and bottom) line up the edge of one of the cone pieces to the center line of the housing.
 - Make sure the raised part of the rubber gasket is inside the cone assembly and not underneath it or crushed anywhere.
- Using the included **#3 Phillips Bit from Bag 1 (Tools)** and (1) **#14-10 x 2" Screw from Bag 5 (Part 1)** at each of the venturi section connections, secure the cone assembly to the housing
- Recheck the rubber gasket for proper placement and make adjustments as needed
- Secure all 8 cone sections to the housing using the included **#3 Phillips Bit from Bag 1 (Tools)** and (6) **#14-10 x 2" Screws from Bag 5 (Part 1)** per cone section.

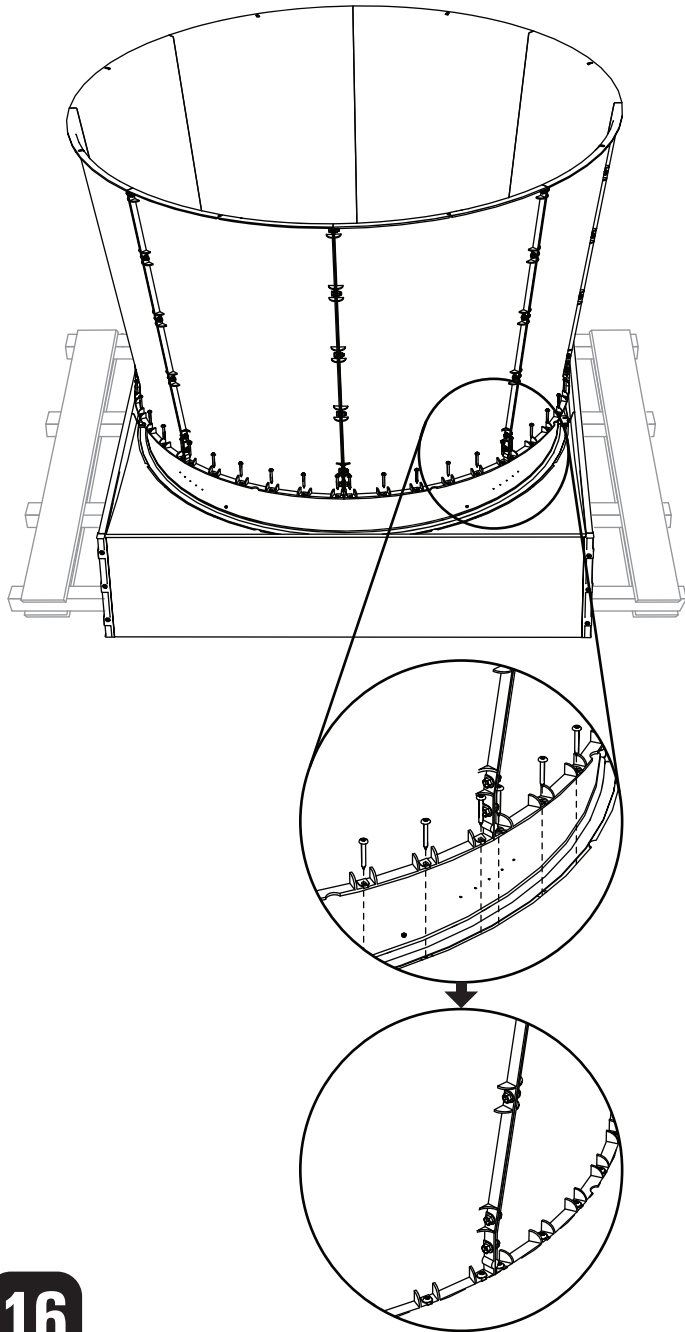

16

Front Guard Installation:

- Place front guards onto cone and align guard tabs to the mounting holes in the cone flange.
- Secure guard to cone using (8) 5/16"-18 x 1" **Bolts** and (8) 5/16"-18 **Serrated Flange Nuts from Bag 6 (Cone Guard)**
- Disassemble the (1) **Front Guard Plate Hub w/Hardware from Bag 9 (Misc. Hardware)**, insert hub bolt post between the two front guard pieces, center, and secure with washer and nut.

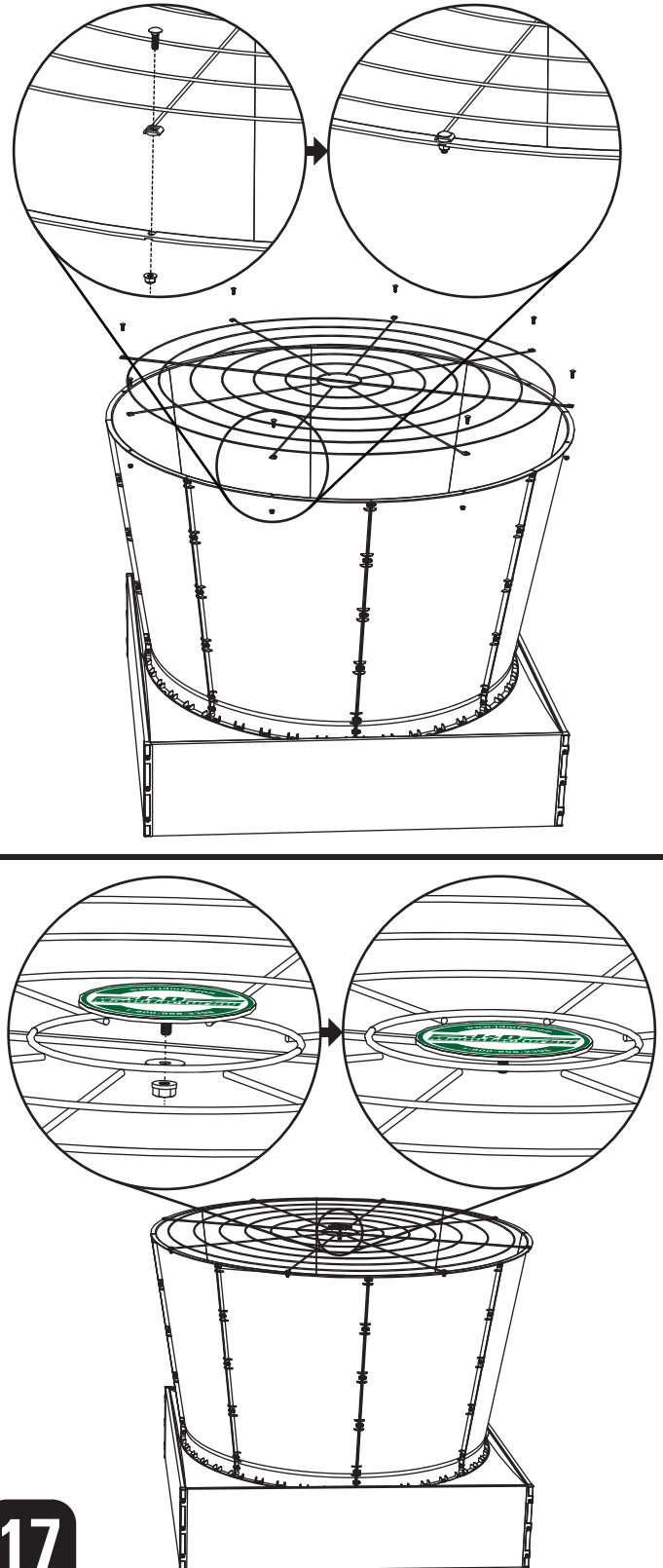

17

Damper Door Spring Installation:

- Hook the (2) SS Damper Door Springs from Bag 9 (Misc. Hardware), onto the eyebolts.
- Swing the loose end of the damper door spring over to the pre-drilled holes on the damper door edge and hook the end of damper door spring through hole which is closest to the spring end and gives the least amount of tension.

NOTE: Test damper door spring tension, if damper doors do not fully close select the next hole over and retest spring tension. Continue until the correct spring tension is found.

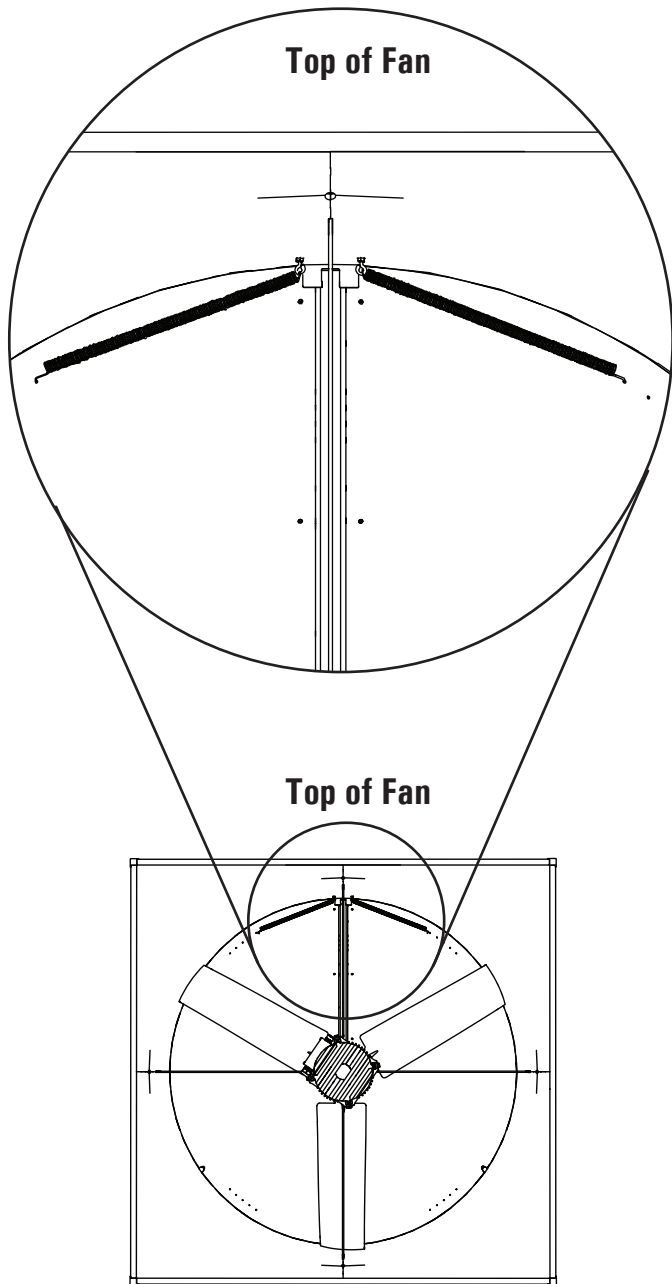

18

Magnum Installation:

- From the exterior of the building insert fan into opening.
- Using the included #3 Phillips Bit from Bag 1 (Tools) and (4) #12-11 x 3 1/2" Screws from Bag 7 (Mounting Screws) secure fan in opening as shown below.

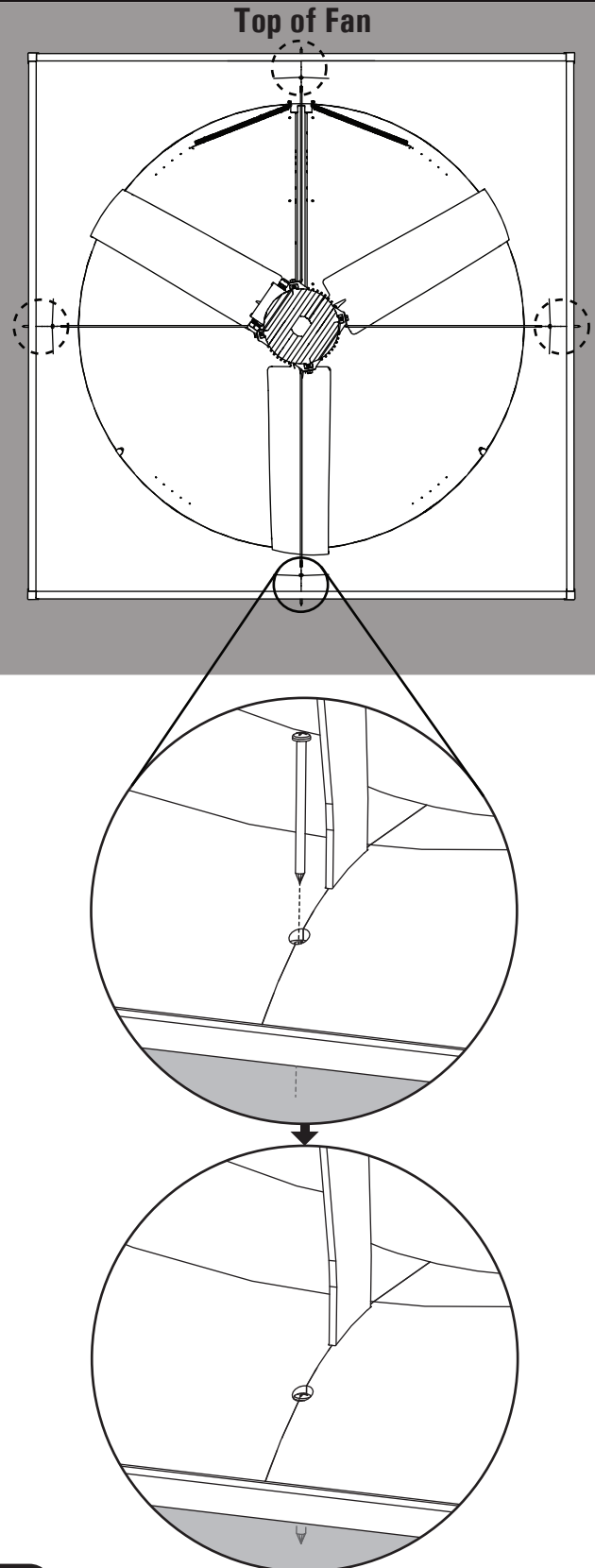

19

Rear Guards Installation:

- Using the included #3 Phillips Bit from Bag 1 (Tools) and (5) #12-11 x 5/8" Screws from Bag 8 (Motor Guard) per guard, secure rear guard sections to housing as shown below.
- Secure rear guard sections to each other using (4) 11" Cable Ties from Bag 9 (Misc. Hardware).

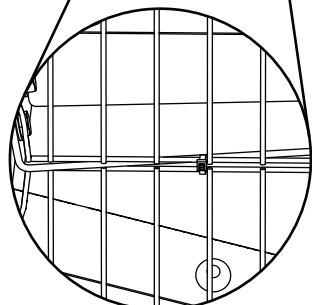
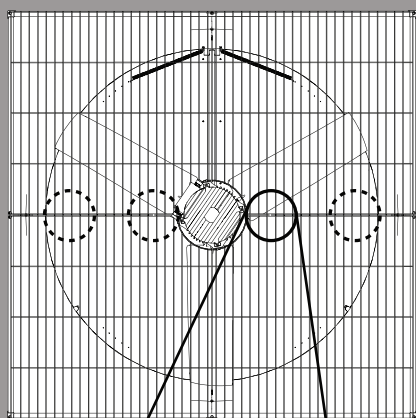
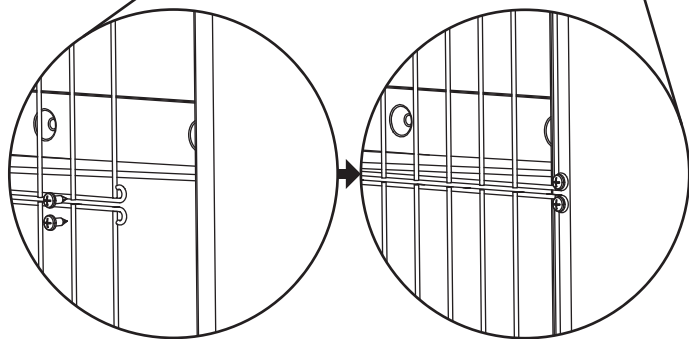
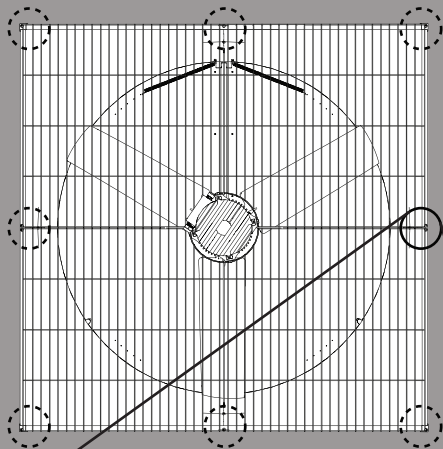

20



DISCONNECT POWER
BEFORE INSTALLING OR SERVICING.



ALL ELECTRICAL WORK SHOULD BE COMPLETED BY
QUALIFIED PERSONNEL AND MEET NATIONAL (NEC),
REGIONAL AND LOCAL ELECTRIC CODES.

Identify cords coming from motor

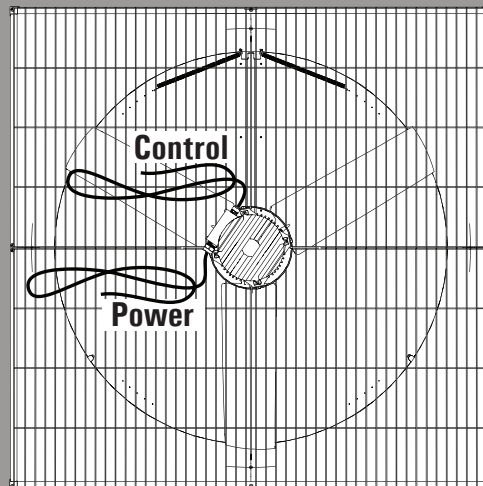

General Wiring Instructions:

- Wiring should only be performed by a trained electrician to prevent injury or death.
- Install manual disconnect switch inside building adjacent to fan.
- Route wire to motor with drip loop and secure. Drip loop will drain accumulated moisture away from the motor.
- Configure internal wires to match supply voltage and wire according to motor nameplate. Test to verify correct rotation.
- Only permit power to unit when guards are properly installed to prevent injury.

Control Wiring Instructions:

- For dry contact ON/OFF control, connect dry contact from STOP/RUN to signal ground.
 - Closed contact is motor ON, open contact is motor OFF.
 - Connect STOP/RUN wire to signal ground wire if dry contact ON/OFF control is not used.
- Use the two 4-20ma IN wires for analog current speed control.
 - Leave 4-20ma wires disconnected if not used, (less than 5.6ma is OFF).
- 0-10V in to signal ground for analog voltage speed control, (less than 1V is OFF).
 - Connect 10V OUT wire to 10V IN wire for no speed control, (full speed).
- Use four conductor 26AWG (or heavier), shielded, dual twisted pair, signal wire with drain wire from J&D control to Permanent Magnet fan.

Single Phase Wired for 190-240v

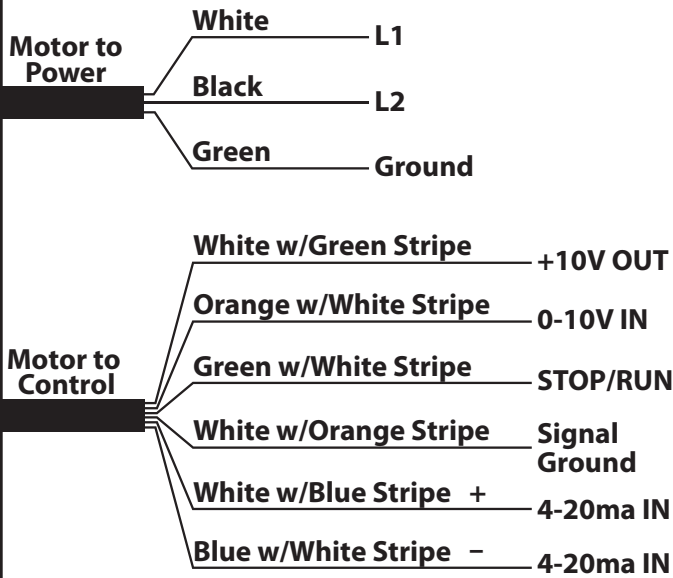

- Use the two 4-20ma IN wires for analog current speed control.
- Leave 4-20ma wires disconnected if not used, (less than 5.6ma is OFF).

Three Phase Wired for 190-240v / 380-460v

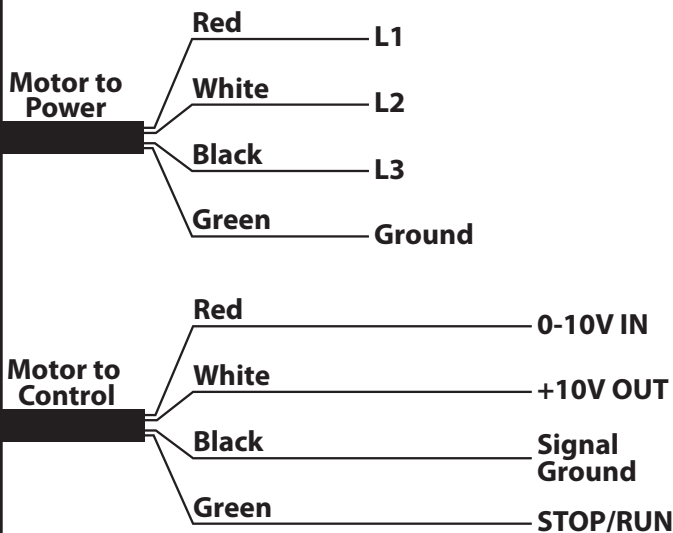

Maintenance Instructions:

- Disconnect power before cleaning or maintaining your fan in order to prevent serious injury or death.
- Service and repair of fan should only be completed by a qualified technician.
- For maximum efficiency and fan life, keep the following free from dirt and dust: blades, damper doors, motor and guard.
- The totally enclosed air over motor has sealed ball bearings and does not require additional oil.