

Excellent for use in higher static pressure applications in factories, warehouses and mills for fume, smoke or dust removal. Provides dependable performance with little maintenance.

FEATURES

- Cast aluminum, spark resistant propellers standard
- Suitable for use in hazardous locations with addition of explosion proof motor
- Low maintenance
- Lighter weight than belt driven units
- Heavy duty, spun venturi panel with rugged all welded motor support structure

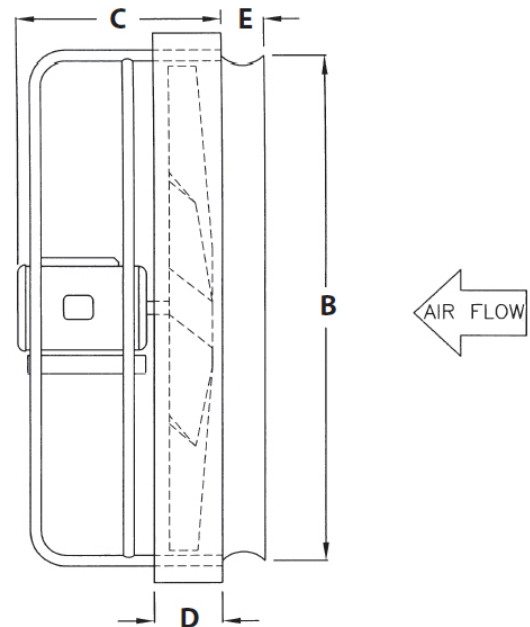
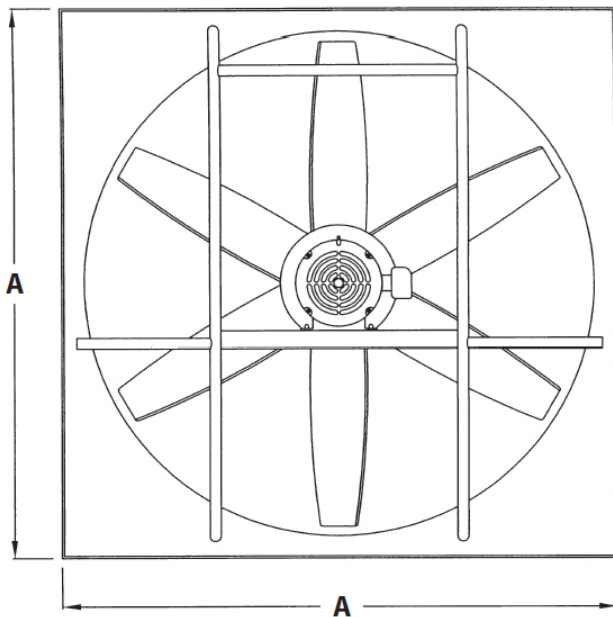

DIMENSIONS

Model	A	B	C	D	E
N912	16"	13"	11"	1"	1-1/4"
N916	20"	17-1/2"	11"	1"	2-1/4"
N918	24"	19-1/2"	13"	1"	2-1/2"
N920	24"	21-1/2"	13"	1"	2-3/4"
N924	30"	25-1/2"	15"	2-3/4"	3-1/2"
N930	36"	31-1/2"	15"	2-3/4"	3-1/2"
N936	42"	37-1/2"	15"	2-3/4"	4"
N942	48"	44"	18"	2-3/4"	4-1/4"
N948	54"	50-1/2"	20"	2-3/4"	4-1/2"
N954	60"	56-1/2"	22"	2-3/4"	4-3/4"
N960	66"	62"	22"	2-3/4"	5"

OPTIONAL ACCESSORIES

- Fan & shutter mounting box
- Front & rear OSHA compliant guards
- All aluminum gravity exhaust shutter
- Weather hood with birdscreen
- Motorized exhaust or intake shutter

PERFORMANCE DATA

Blade Diameter	Model	Horse Power	RPM	Free Air	1/8" SP	1/4" SP	3/8" SP	1/2" SP	3/4" SP	1" SP	1-1/4" SP	1-1/2" SP
12"	N912-A	1/4	1725	1180	930	520	-	-	-	-	-	-
16"	N916-A	1/4	1725	2800	2400	2000	1400	700	-	-	-	-
	N916L-A	1/4	1140	2100	1700	500	-	-	-	-	-	-
18"	N918-B	1/3	1725	3375	3000	2600	2000	1400	-	-	-	-
	N918-C	1/2	1725	4150	3850	3150	2800	1700	-	-	-	-
20"	N920L-A	1/4	1140	2800	2560	2380	1400	-	-	-	-	-
	N920-A	1/4	1725	3720	3160	2510	1650	-	-	-	-	-
	N920-C	1/2	1725	4800	4450	3950	3340	2500	-	-	-	-
	N920-E	1	1725	6900	6600	6200	5900	5500	3700	850	-	-
24"	N924-A	1/4	1725	5200	4200	2820	1050	-	-	-	-	-
	N924L-B	1/3	1140	4975	4690	4250	3920	2850	-	-	-	-
	N924-C	1/2	1725	6510	5880	5200	4150	3100	1800	-	-	-
	N924L-C	1/2	1140	6840	6100	5170	1900	-	-	-	-	-
	N924-D	3/4	1725	6900	6510	5900	5440	4650	2750	-	-	-
	N924L-D	3/4	1140	6900	6450	6265	5600	3300	-	-	-	-
	N924-E	1	1725	7425	7000	6350	5850	5000	3300	1775	-	-
	N924-G	2	1725	9525	9196	8810	8360	7980	6960	3000	-	-
N924-H	3	1725	10500	9800	9500	9100	8700	7800	5000	3600	-	
30"	N930L-B	1/3	1140	6950	5550	3900	1500	-	-	-	-	-
	N930-C	1/2	1725	8980	7650	6300	5400	4350	2300	-	-	-
	N930L-C	1/2	1140	7500	6150	4400	2200	-	-	-	-	-
	N930L-D	3/4	1140	10440	9750	8750	7640	6000	-	-	-	-
	N930LL-E	1	870	10640	10450	9800	9000	7900	-	-	-	-
	N930-F	1-1/2	1725	12000	11250	10450	9600	8700	6700	-	-	-
	N930L-F	1-1/2	1140	13350	12500	11450	10200	8000	5000	-	-	-
	N930L-G	2	1140	14000	14000	13750	12900	11850	10450	2500	-	-
N930-H	3	1725	16000	15350	14700	13850	12900	10200	8000	6000	-	
36"	N936L-E	1	1140	13600	12000	11100	9000	7500	2800	-	-	-
	N936LL-G	2	870	17600	16500	15200	13620	11400	-	-	-	-
	N936L-G	2	1140	17620	16500	15200	13620	12300	8500	-	-	-
	N936L-H	3	1140	20500	19500	18500	17100	15850	11600	6500	-	-
	N936-I	5	1725	23000	22150	21100	20200	19000	18100	16400	14500	6000
42"	N942L-G	2	1140	17964	17277	15326	13990	12351	7600	-	-	-
	N942L-H	3	1140	24500	23150	23000	22000	19650	14000	10000	-	-
	N942L-I	5	1140	28970	27960	26840	25700	24200	19500	13800	2000	-
	N942LL-E	1	870	15800	15200	13480	12310	5800	900	-	-	-
	N942LL-G	2	870	22040	21000	20500	18500	15000	6000	-	-	-
48"	N948L-H	3	1140	28600	26500	24400	22000	20000	15900	11000	-	-
	N948L-I	5	1140	32000	30493	28900	27173	25432	21054	14985	7100	-
	N948LL-H	3	870	28700	26500	24200	21600	18500	10000	-	-	-
	N948LL-I	5	870	33000	31500	29750	27650	25300	18000	-	-	-
60"	N960L-I	5	1140	45000	41000	37000	33500	28500	16000	2500	-	-
	N960LL-I	5	870	45200	41500	37000	33000	26000	14000	-	-	-
	N960LL-J	7-1/2	870	47000	45500	43600	41000	38700	33000	24000	-	-
	N960LL-K	10	870	57200	54400	51000	48500	45000	38000	29500	-	-

MODEL NUMBER SCHEMATIC

