

48" Direct Drive Supply Fan with 54" Filter Section

APPLICATION

This air movement system is designed for the demanding environment of a crypto-mining shipping container. Specifically engineered with a shallow mounting depth, higher HP motors, and larger filter sections, these units supply a high volume of clean filtered air to keep your miners cool. This is an all-in-one solution, complete with mounting box, gravity operated intake shutter, and easily-accessible filters.

SPECS & DETAILS

- 3 HP, 1170 RPM, Maintenance Free Direct Drive TEFC Motor, Inverter Duty
- 3 Phase, 60Hz, 230V/460V (able to run on 415V 60hz)
- 20,000 CFM @ 0.5" WG
- 77 dBA @ 5'
- Disposable 2" filters are high capacity, pleated type that meet MERV 8 rating
- Designed and built in the USA

OPTIONAL ACCESSORIES

- Electrically operated exhaust shutter for opposite wall (passive exhaust)
- 48" 20,000 CFM exhaust fan for opposite wall (forced exhaust)
- Inlet weatherhood and/or birdscreens for intake fans
- VFD for speed control and phase converters for adapting to nearly any power source

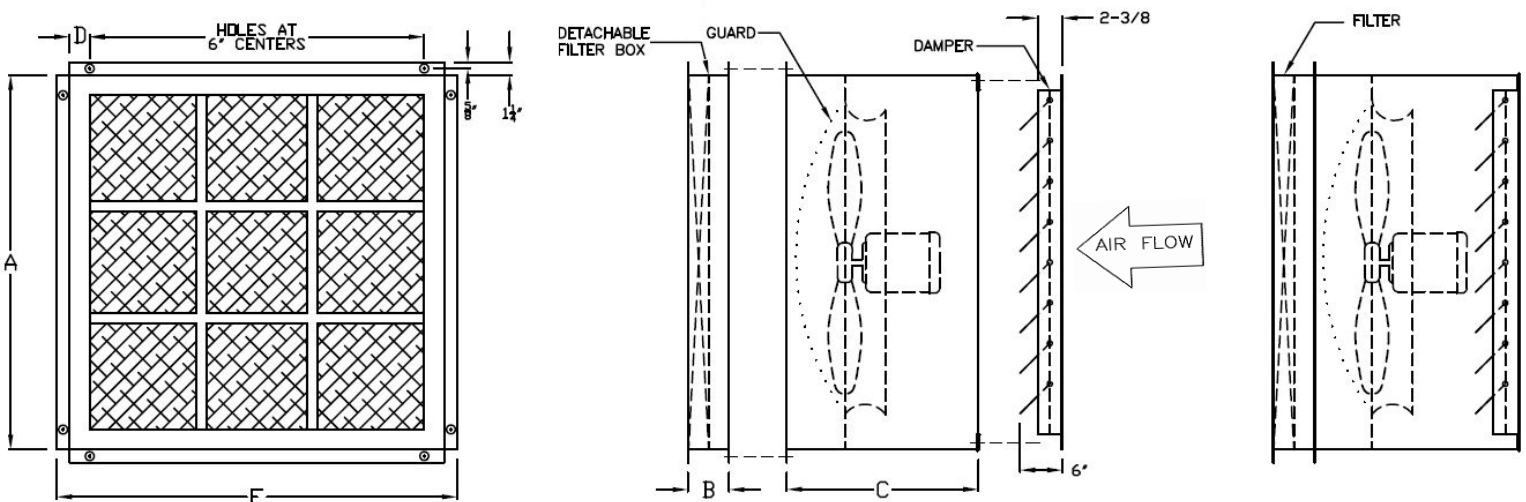

Model #	A	B	C	D	F	Rough in Opening	Filter Size
NFC48-3-S	54.25"	4"	30"	5.12"	56.75"	54.75"	18"x18"x2" (qty 9)