

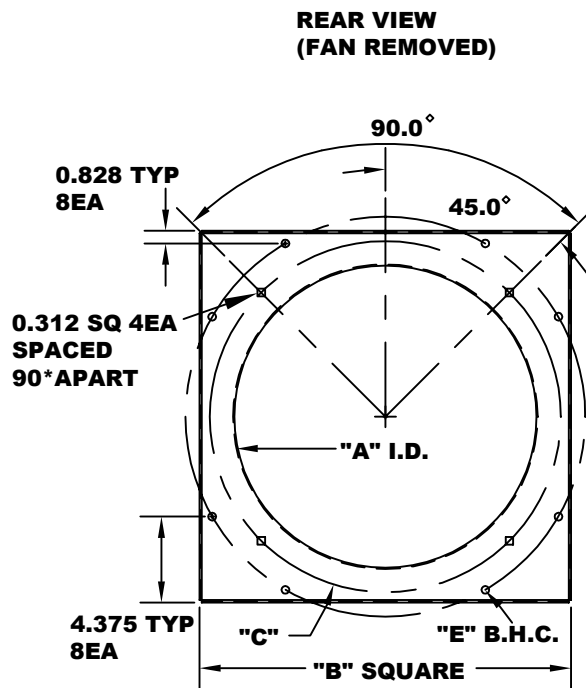

**CE VENTURI MOUNTED SERIES**

UPC 686334	SIZE	MODEL	HP	CFM			AMPS HIGH	SHIPPING WEIGHT(LBS)
				HIGH	MED	LOW		
868034	10"	CE 10-DV	1/12	680	540	460	1.0	11
798662	12"	CE 12-DV	1/12	825	710	560	1.1	17
869041	14"	CE 14-DV	1/8	1520	1400	1250	2.0	17
869058	16"	CE 16-DV	1/8	2100	1900	1700	2.1	18
798679	18"	CE 18-DV	1/8	2300	2100	1850	2.2	26
869065	20"	CE 20-DV	1/4	2925	-	2380	2.3	34
798686	24"	CE 24-DV	1/4	3400	-	2770	2.5	48
798693	30"	CE 30-DV	1/4	3950	-	3080	2.7	55

- \* **SIZE:** 10 THRU 30"
- \* **MOTOR:** 120V, 1-PHASE TOTALLY ENCLOSED PERMANENTLY LUBRICATED-UL LISTED  
- 1/12 HP MOTOR IS 3-SPEED SLEEVE BEARING SHADED POLE TYPE  
- 1/8 HP MOTOR IS 3-SPEED SLEEVE BEARING PERMANENT SPLIT CAPACITOR  
- 1/4 HP MOTOR IS 2-SPEED BALL BEARING PERMANENT SPLIT CAPACITOR
- \* **SWITCH:** PULL CHAIN TYPE
- \* **CORD:** NONE, JUNCTION BOX PROVIDED FOR DIRECT WIRING
- \* **BLADE:** ALUMINUM
- \* **GUARDS:** STEEL SPIRAL WIRE
- \* **INSTALLS ON INSIDE OF WALL**
- \* **CAN BE USED WITH EXTERNAL SHUTTER**

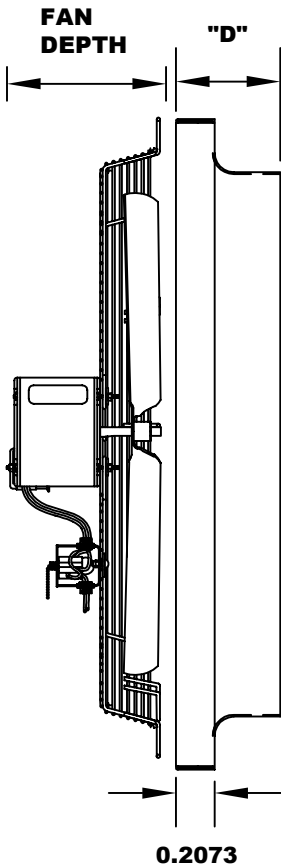

CE VENTURI MOUNTED						
SIZE	FAN DEPTH	DIMENSIONS				
		"A"	"B"	"C"	"D"	"E"
10"	5.81	10.250	12.63	12.375	2.000	12.875
12"	7.18	12.250	14.50	14.375	2.000	14.625
14"	7.18	14.250	17.13	16.375	2.500	17.375
16"	7.18	16.250	19.13	18.250	2.875	20.000
18"	7.18	18.125	21.00	21.750	2.750	22.875
20"	7.18	20.250	23.13	23.686	2.750	25.625
24"	7.18	24.250	29.50	27.750	2.875	27.875
30"	7.18	30.250	33.50	33.750	2.875	33.875

OPTIONAL WALL SHUTTERS					
UPC 686334	SIZE	MODEL	WIDTH LENGTH		WT LBS
			868433	10"	
798556	12"	CE 12-G	15.13	15.13	5.5
868457	14"	CE 14-G	17.13	17.13	6.5
851473	16"	CE 16-G	19.00	19.00	8
798563	18"	CE 18-G	21.13	21.13	9
797528	20"	CE 20-G	23.13	23.13	10
798570	24"	CE 24-G	27.13	27.13	13
798587	30"	CE 30-G	33.13	33.13	19

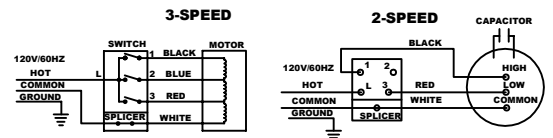

QTY	CATALOG NUMBER	TAG	SIZE	VOLTS	AMPS	OPTIONAL ACCESSORIES	NOTES

SUBMITTED BY:	DATE:
APPROVED BY:	DATE: