

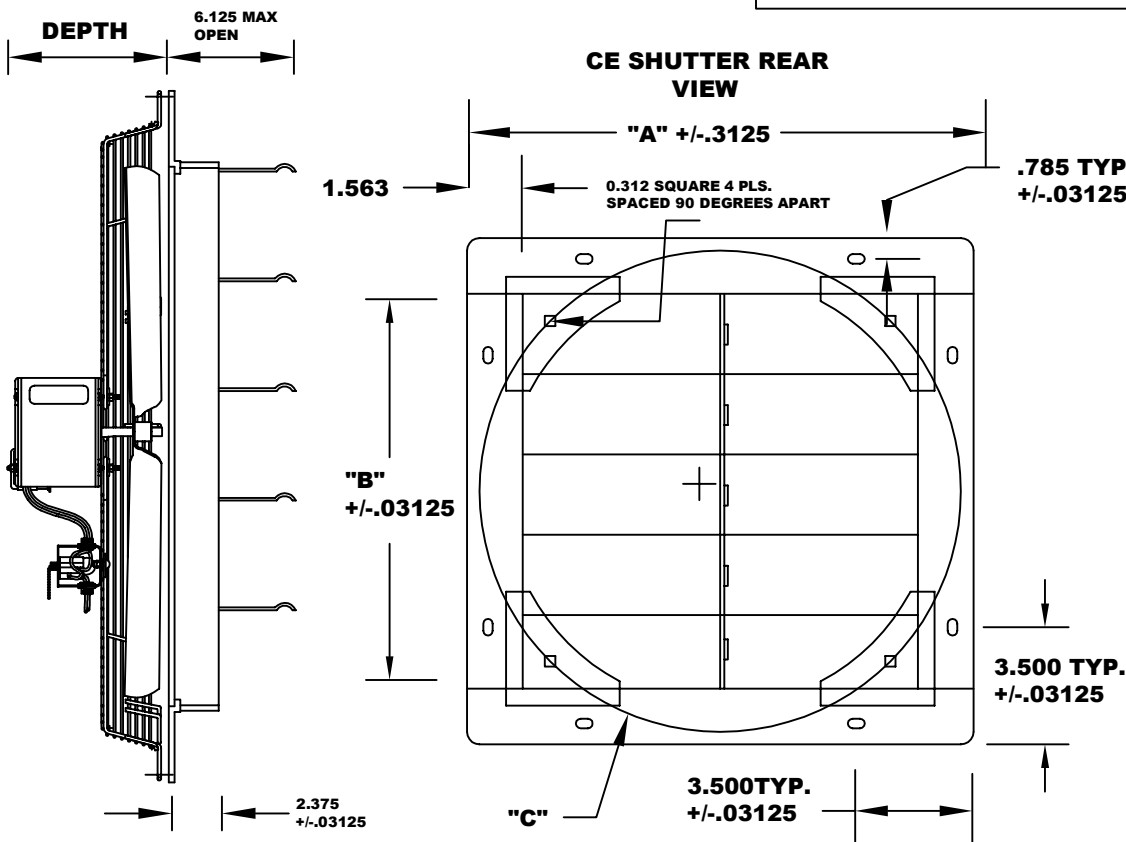

**CE SHUTTER MOUNTED SERIES**

UPC 686334	SIZE	MODEL	HP	CFM			AMPS HIGH	SHIPPING WEIGHT(LBS)
				HIGH	MED	LOW		
868990	10"	CE 10-DS	1/12	680	540	460	1.0	11
798624	12"	CE 12-DS	1/12	825	710	560	1.1	12
869003	14"	CE 14-DS	1/8	1520	1400	1250	2.0	17
869010	16"	CE 16-DS	1/8	2100	1900	1700	2.1	18
798631	18"	CE 18-DS	1/8	2300	2100	1850	2.2	19
869027	20"	CE 20-DS	1/4	2925	-	2380	2.3	34
798648	24"	CE 24-DS	1/4	3400	-	2770	2.5	38
798655	30"	CE 30-DS	1/4	3950	-	3080	2.7	42

- \* **SIZE:** 10 THRU 30"
- \* **MOTOR:** 120V, 1-PHASE TOTALLY ENCLOSED PERMANENTLY LUBRICATED-UL LISTED
  - 1/12 HP MOTOR IS 3-SPEED SLEEVE BEARING SHADED POLE TYPE
  - 1/8 HP MOTOR IS 3-SPEED SLEEVE BEARING PERMANENT SPLIT CAPACITOR
  - 1/4 HP MOTOR IS 2-SPEED BALL BEARING PERMANENT SPLIT CAPACITOR
- \* **SWITCH:** PULL CHAIN TYPE
- \* **CORD:** NONE, JUNCTION BOX PROVIDED FOR DIRECT WIRING
- \* **BLADE:** ALUMINUM
- \* **GUARDS:** STEEL SPIRAL WIRE
- \* **SHUTTER PANEL:** 19GA STEEL
- \* **SHUTTER BLADES:** 26GA ALUMINUM, UNFINISHED
- \* **RPM** 1650,1550,1300



SIZE	DEPTH	DIMENSIONS		
		"A"	"B"	"C"
10"	5.81	13.125	10.00	12.375
12"	7.18	15.125	12.00	14.375
14"	7.18	17.125	14.00	16.375
16"	7.18	19.125	16.00	18.250
18"	7.18	21.125	18.00	21.750
20"	7.18	23.125	20.00	23.686
24"	7.18	27.125	24.00	27.750
30"	7.18	33.125	30.00	33.750

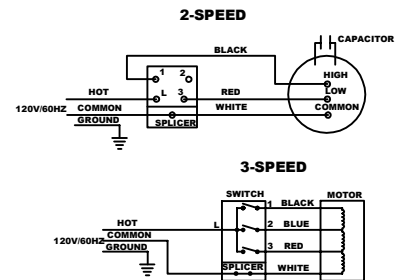

QTY	CATALOG NUMBER	TAG	SIZE	VOLTS	AMPS	OPTIONAL ACCESSORIES	NOTES

SUBMITTED BY:	DATE:
APPROVED BY:	DATE: