



clearwater
LIGHTS™



Installation Manual

BMW R1300GS

Darla LED Light Kit

Dimmable

Patent Pending



Made in USA

Bike Preparation and General Info

Bike Preparation:

- First, park the motorcycle on hard pavement or concrete to insure the bike will be stable during the installation. If you can mount the bike on a stand with tie-down straps, this will help secure the motorcycle
- Follow the manufacturers guidelines for disconnecting the battery. This is important to prevent damage to the electrical system



Installation Tips:

There are two main parts to the installation of your new Clearwater Lights. The mechanical portion, and the electrical portion. With this manual, we will go over the basics of both which should allow you to get your lights up and running. If you purchased a bracket made specifically for your bike, refer to our manuals online for that specific installation at:

www.clearwaterlights.com

Note: Engine needs to be turned on before the lights will function

*Please be sure to read our instructions thoroughly
before attempting installation*

Tools that may be needed for installation:

1. **Torx T25**
2. **Torx T40**
3. **M5 Alan Key**
4. **M8 Alan Key**
5. **M10 Alan Key**
6. **17mm Wrench**

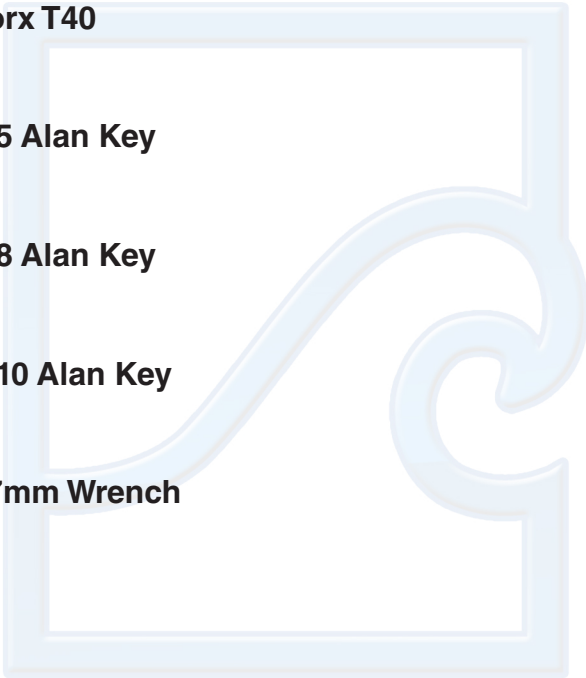

Disassembly



1. Remove the seats, ensuring to disconnect the seat warmer cables



Disassembly

2. To remove the front fairing first loosen the clear plastic guards on the front left and right by removing the two T25 screws on each and then move it out of the way



3. remove the two plastic pins from below (they look like screws)



Disassembly

4. The nose piece can be removed with a firm pull from the top and the bottom pulling diagonally upwards. We also recommend digging into the fender from under the blinker as it helps to release a compression fitting



5. Take off the side panels using a T25, there are two screws



Disassembly



6. After the screws are removed, the panel can be pulled off with a firm pull



Wiring Diagram

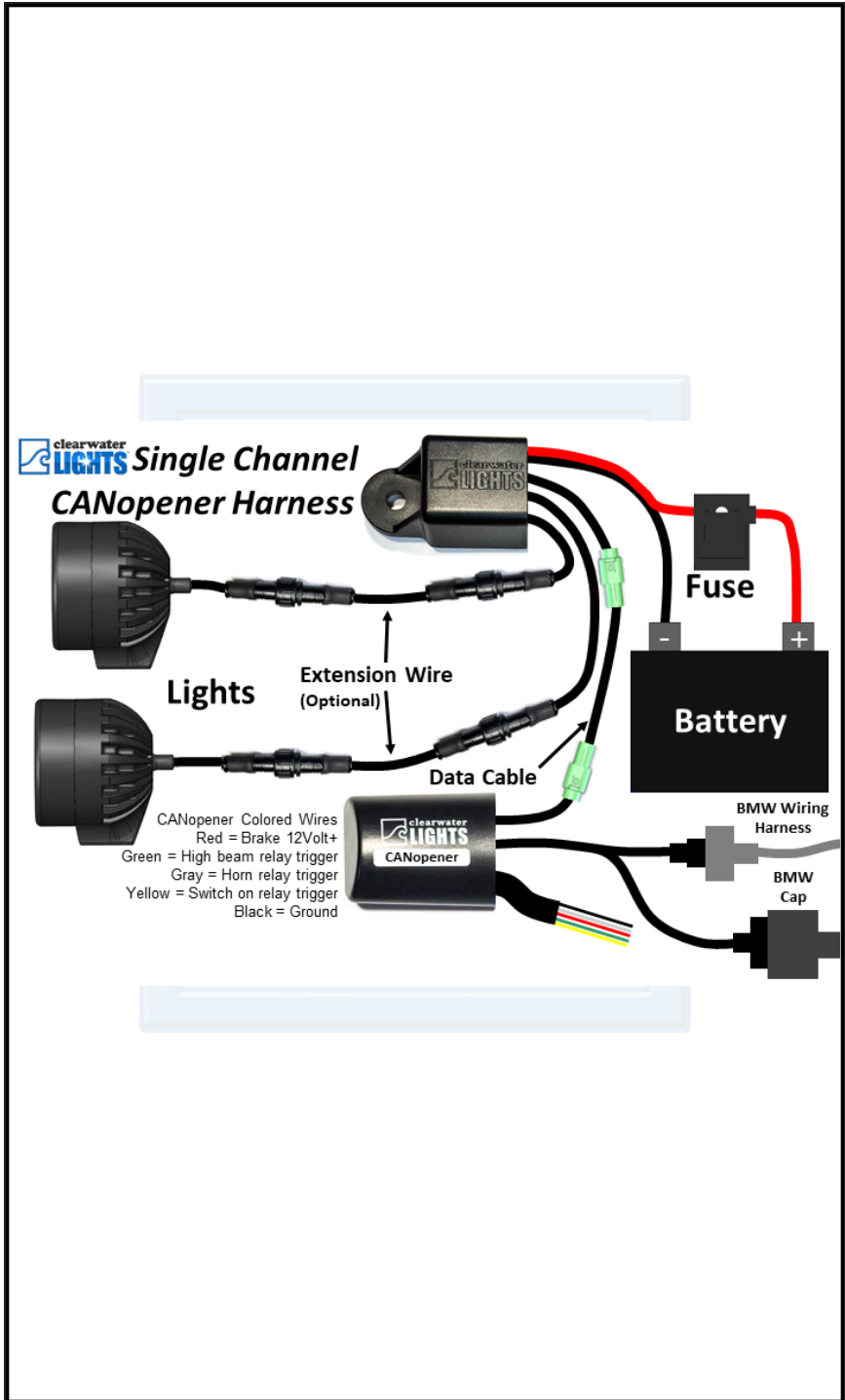

Harness Installation

1. Make room for the harness by moving this connector



2. To do this, release the clip sliding the connector off towards the front. Flip the connector forward and zip tie it in place

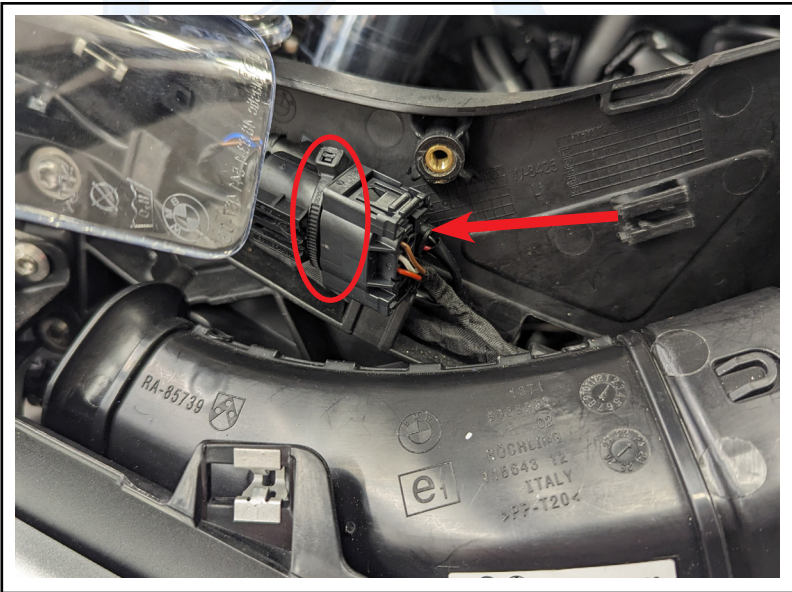

Harness Installation

3. Drop the harness in, routing the wires

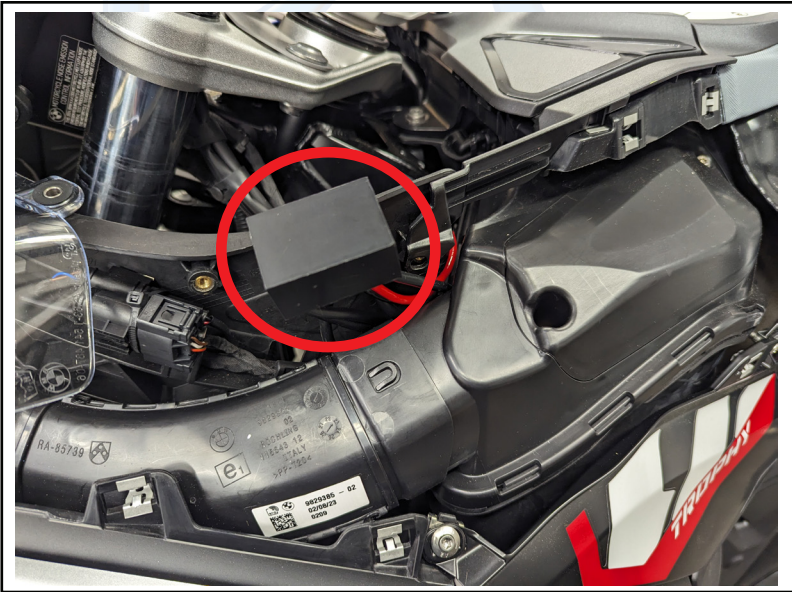
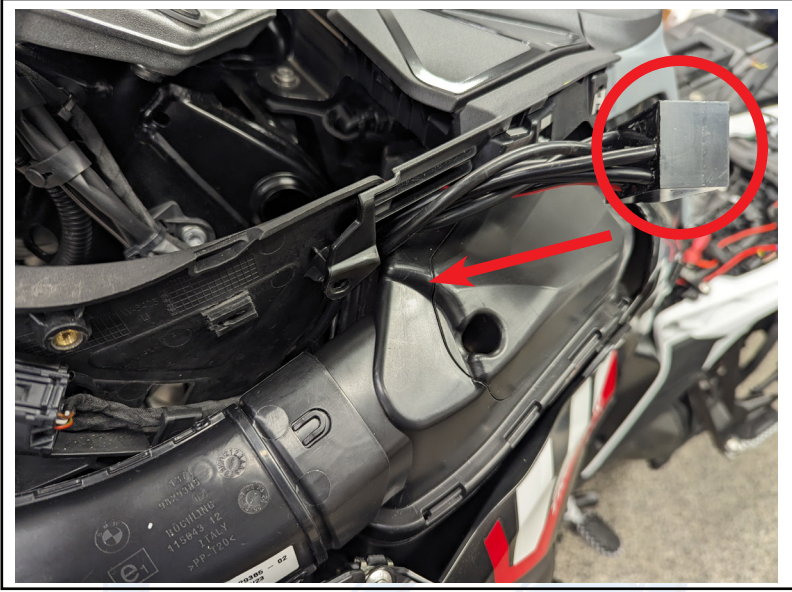

Harness Installation

a. Secure the harness with zip ties in this position

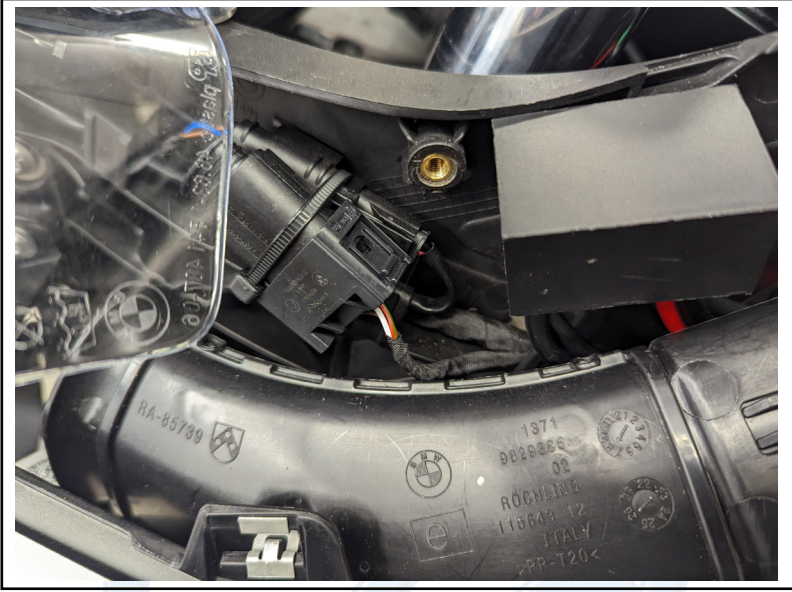

Route the wires

1. Before routing the wires remove these two panels



2. To take off the first panel remove these two screws



Route the wires

3. To take off the second panel just remove this one screw and then pull



4. Plug in data cable extension and then when routing the wires make sure that the data cable is taut and isn't kinked

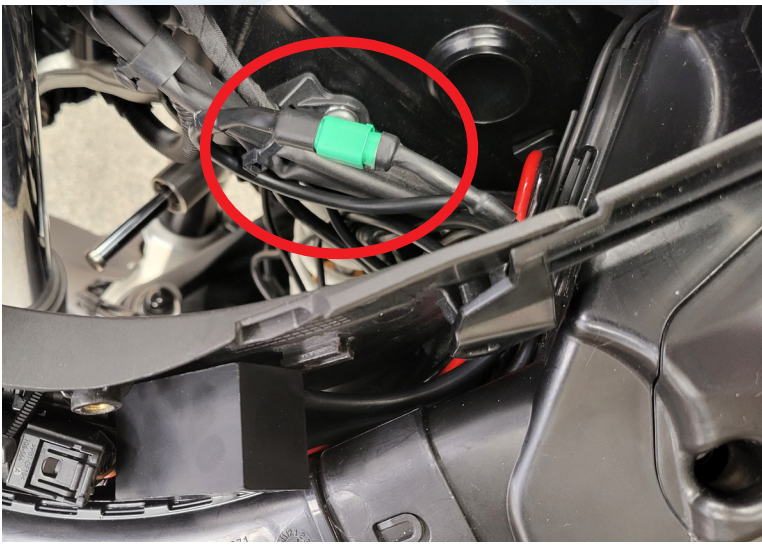

Route the wires

Note:

To route the wire through the frame we recommend getting a thick and long zip tie and then taping the wires to it. This helps to fish the wires through. Although, anything decently strong and flexible can be used as well

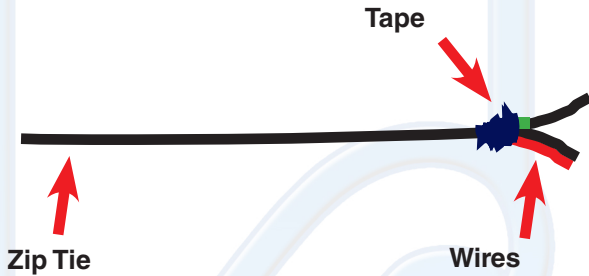

5. Route the wires along the frame as shown (this process can take some time as fishing the wire through can be difficult, **you don't need to take off the fuel tank**)



Route the wires

6. Attach the fuse to the red wire using the provided posi-lock

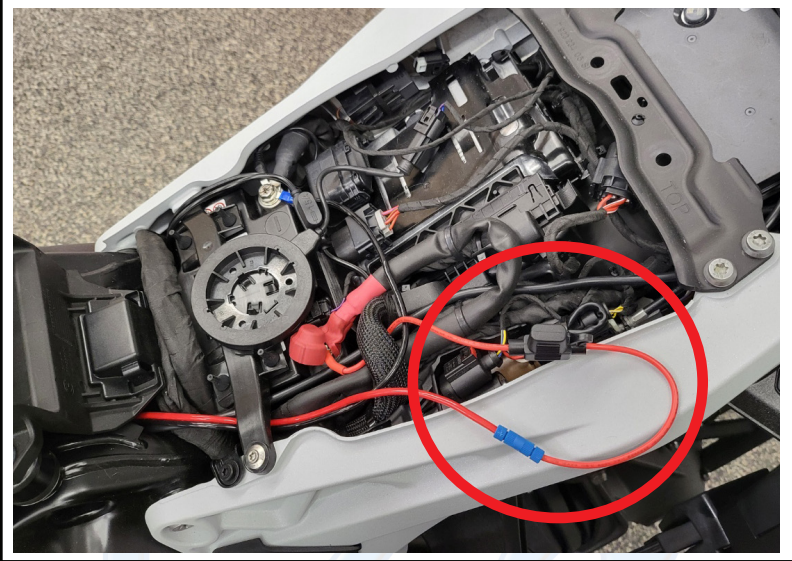

7. Attach the power wire to the positive and negative terminal making sure to **remove the negative first and then putting it back last**

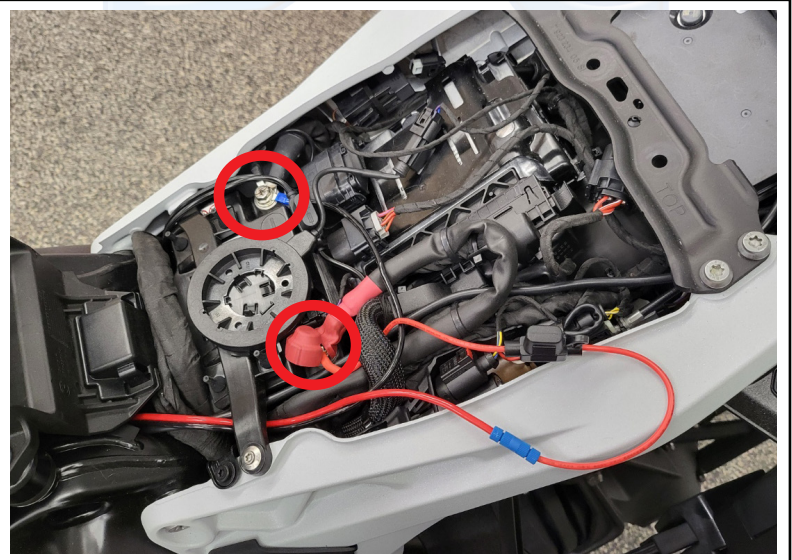

Canopener Installation

1. Make sure that the data cable extends to the back of the bike before continuing

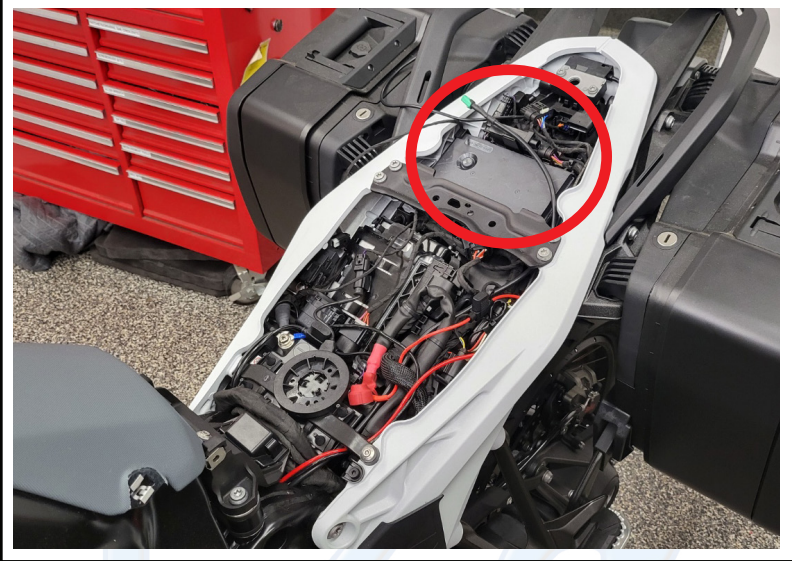

2. Remove this connector at the very back of the bike

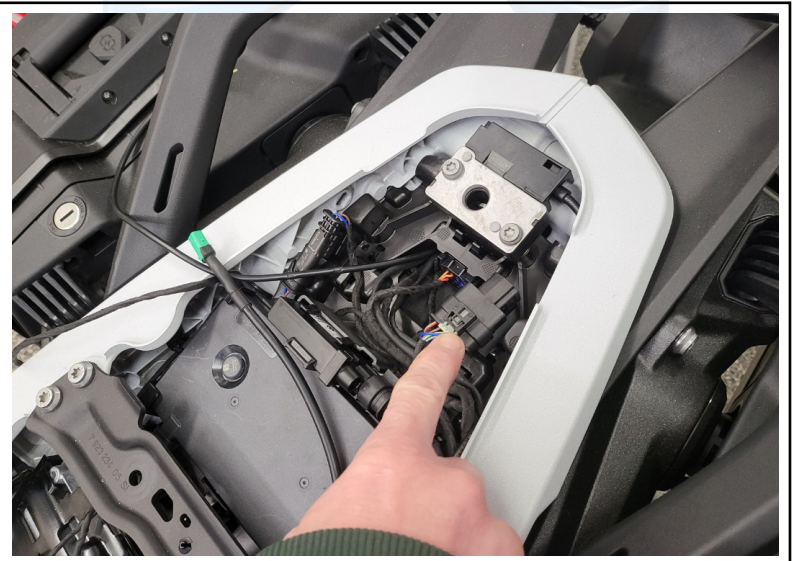

Canopener Installation

3. Plug in the connector to our canopener



4. Plug in the canopener's connector into the port on the bike

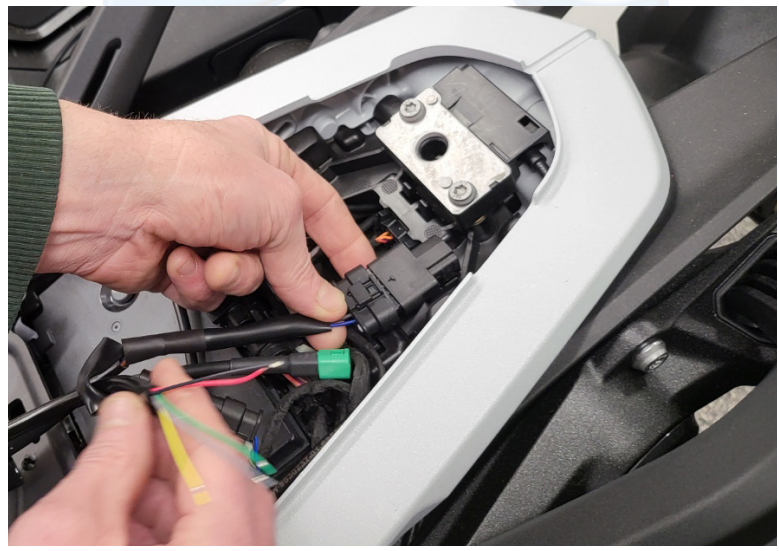

Canopener Installation

5. Plug in the data cable



6. Take off the plastic on the velcro pad and then stick it on the bike

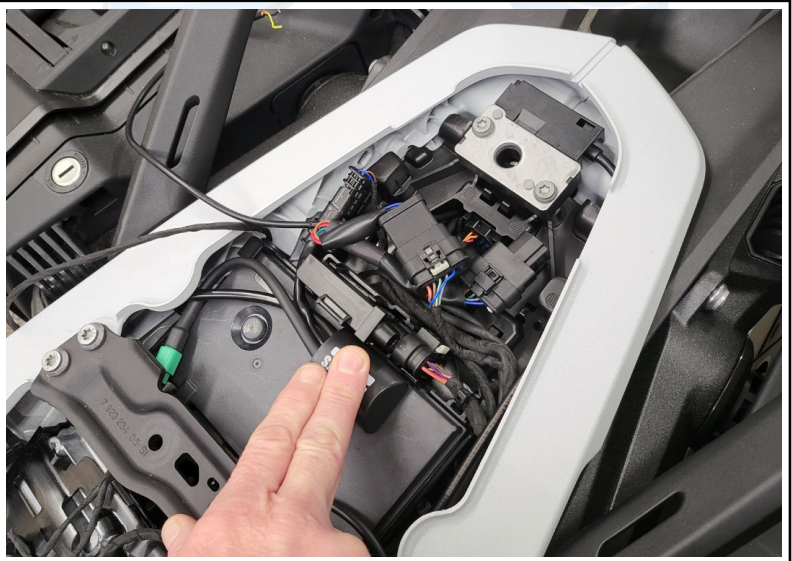

Light Bar/Fog Mount Installation

1. **If installing the light bar or fog mount brackets** then remove the fog lights on both sides and disconnect the wire

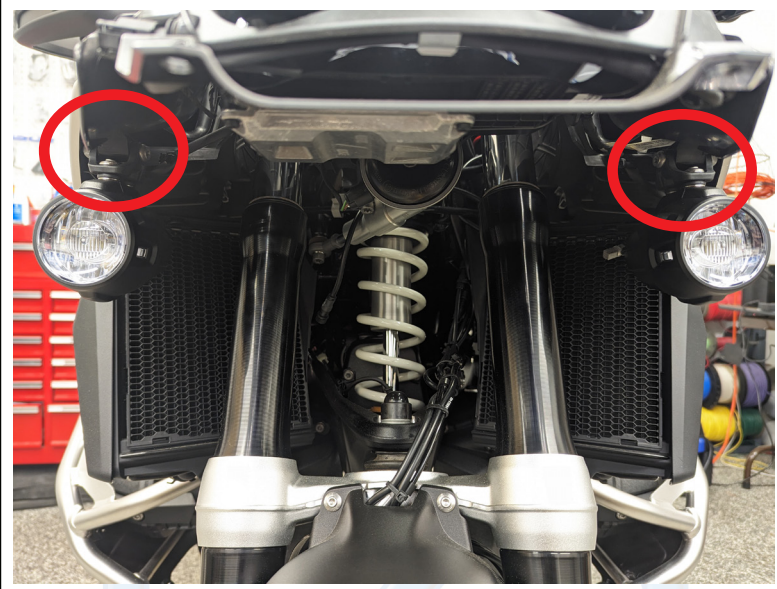

- a. To do this, carefully pull the two clips holding the connector outwards and then you can disconnect the wire



Light Bar Installation

(skip forward for crash bar/fork/fog installation)

1. Take out these three screws on both sides of the bike. On each side, two are T25 and one is T40

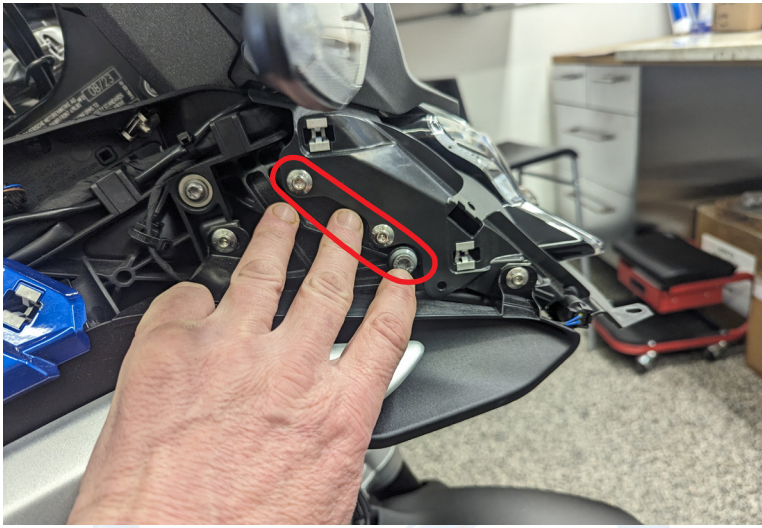

2. Install the left and right brackets by inserting them from the bottom of the bike. On each side, you will use two of the provided M5x20 screws (four total) in place of the T25 screws that were removed before. Additionally, you will **re-use** the T40 screw that was originally in place. **Don't tighten all the way yet**



Light Bar Installation

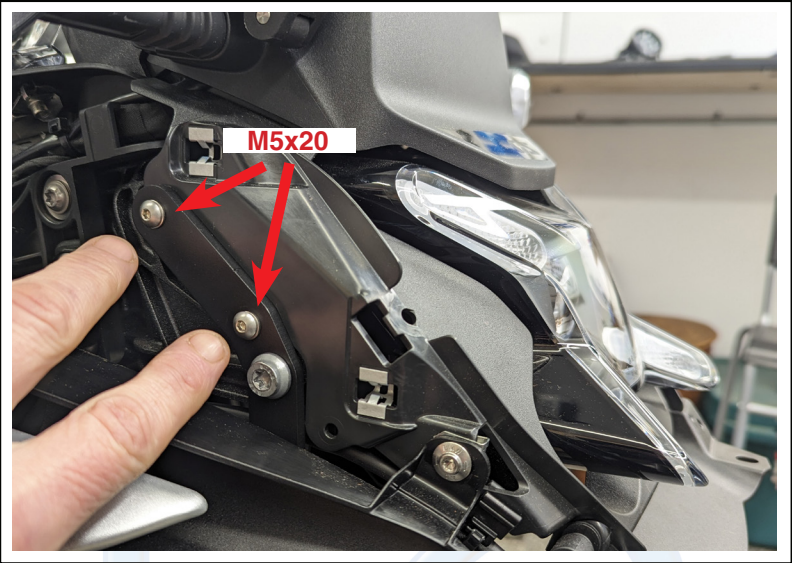

Light Bar Installation

3. Install the bar between the brackets using the M8x16 bolts supplied. Then go back and tighten the screws from the previous step



Light Bar Installation

4. Install the brackets on the left and right side. The curved slider/adjustment slot in the bracket should be toward the rear of the bike



5. Install the Darla with the provided screws and washers



Crash Bar Installation

1. The installation of the crash bar mount can vary based on what crash bars you have, but for the default crash bars we recommend mounting on this bar



2. Install the lights using the diagram below



Fork Mount Installation

1. The installation of the fork mount can vary based on where you want to mount the lights but we recommend to mount them here



2. Install the lights using the diagram below



Fog Mount Installation

1. The installation of the fog mount

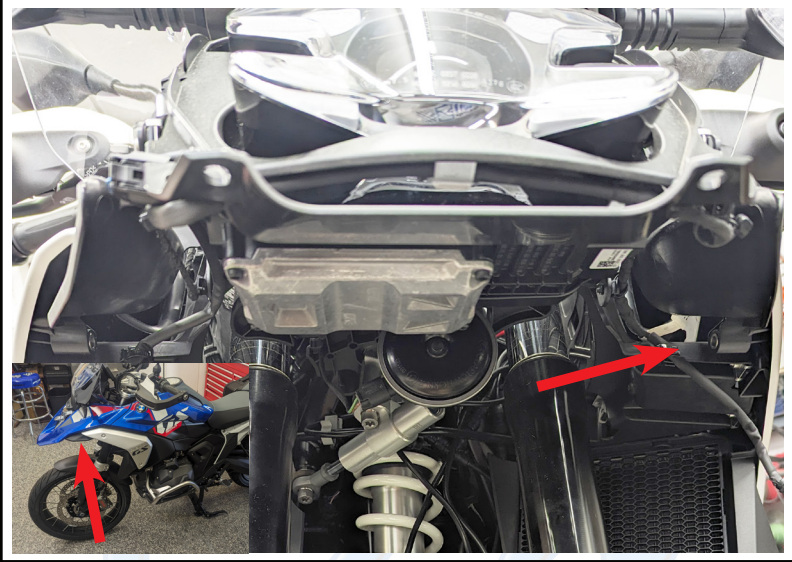

2. Install the lights using the diagram below

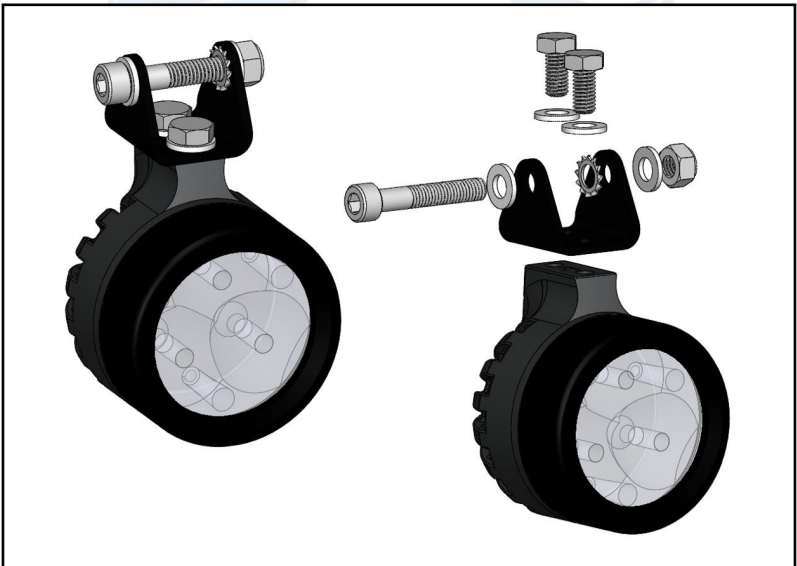

Alignment / Grommet Precaution

Aligning The Lights:

As Erica, Krista, and Sevina are designed as auxiliary lights, adjustment is up to the user depending on his needs. Ask an assistant to help you with this procedure. Make sure the bike is on level ground and have an assistant sit on the bike. With a right angle board or object, position the board on the floor and slide it up to the light. The goal is to adjust the lights so that the light is level with the ground.

Passengers and luggage may alter the alignment of the light, so further adjustments may be needed. You may find that a slight downward angle (**5 degrees**) is helpful. Often times it is helpful to angle the right side light toward the right side of the road. This helps with identifying road terrain and potential critters.



Do Not Kink The Grommet

To maintain the integrity of the water sealling grommet, do not kink, deform or put pressure on the grommet when dressing the wires during install of Clearwater Lights.

Do Not Kink The Grommet

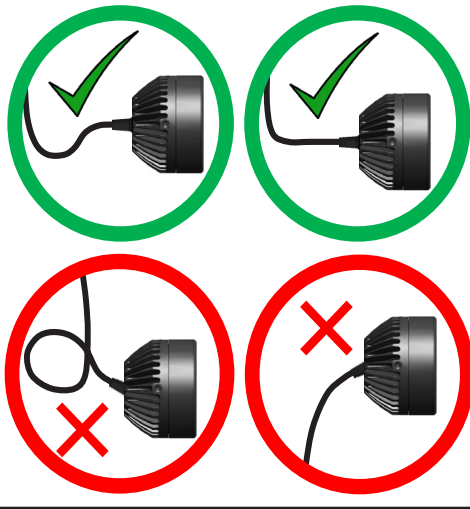

Thank you for purchasing your **Clearwater Lights**. We hope this product will help make you a safer rider. Please feel free to send us comments or suggestions at any time. We learn from you. Visit our website for more exciting products to help you see better at night.

Ride safe!

Sincerely,

Glenn and the team at Clearwater.



The Clearwater Company - 11305 Sunrise Gold Circle, Suite D
Rancho Cordova, CA 95742
Phone: (916) 852-7029 | Fax: (916) 852-9410 | www.clearwaterlights.com

Revised 4/9/2024