



clearwater
LIGHTS™



Installation Manual

Honda Goldwing (2018-2022)

Krista, Erica, Sevina LED Light Kit

Dimmable

Patent Pending



Made in USA

Parts List and Bike Preparation

Please be sure to read our instructions thoroughly before attempting installation.

- Check Parts list supplied with your kit to be sure all parts are handy.
- First, park the motorcycle on hard pavement or concrete to insure the bike will be stable during the installation. If you can mount the bike on a stand with tie-down straps, this will help secure the motorcycle.
- Follow the manufacturers guidelines for disconnecting the battery. This is important to prevent damage to the electrical system.

This Goldwing Mirror Mount Kit is specifically for models 2018-2021. If you have a Goldwing before 2018, this kit will not work.

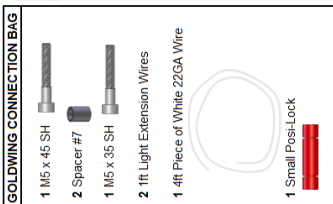

Last updated: 7/28/22

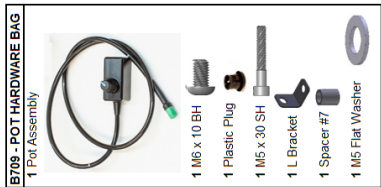
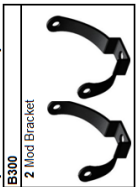
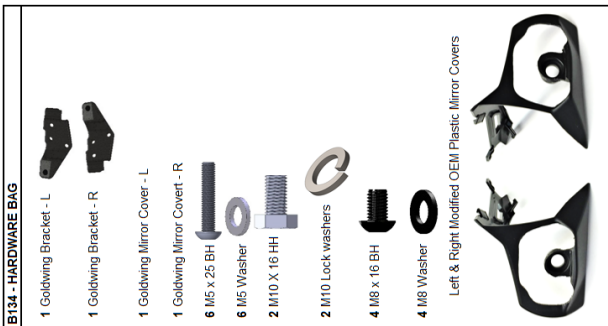

E-K 34 - Goldwing 1800 (2018 - 2022)

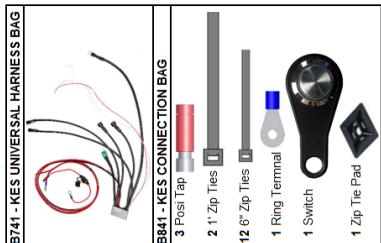

Wiring Diagram

The wiring diagram below serves as an overview for the entire Clearwater Lights system for your Honda Goldwing. Note each component and how they are connected.

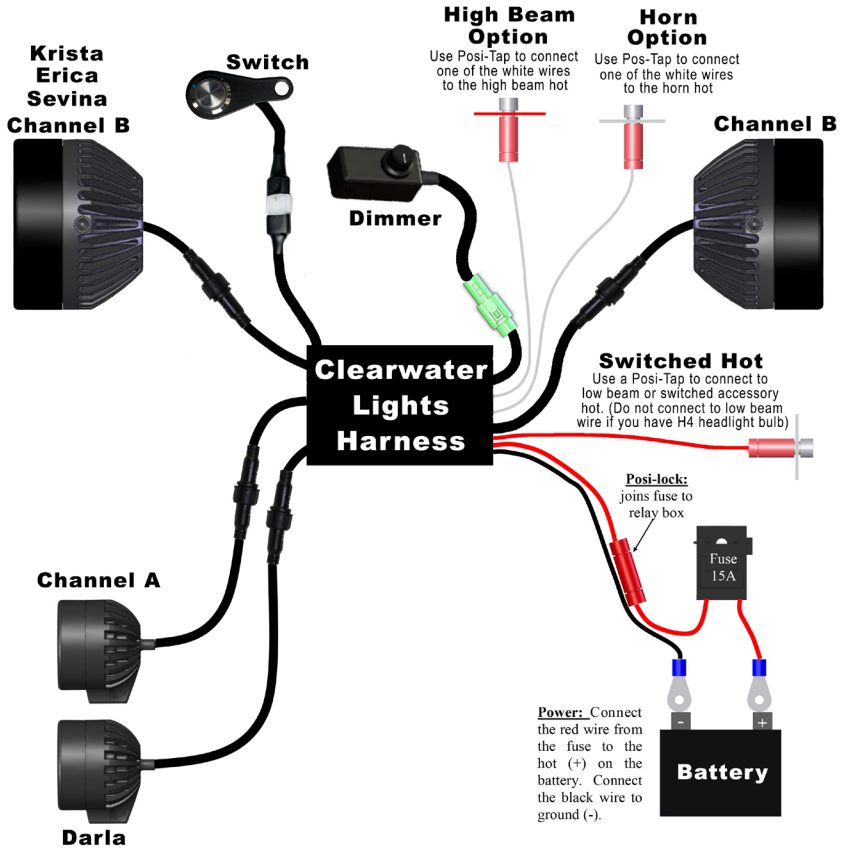

Bike Disassembly

The Left side panel will need to be removed as well as both mirrors and their respective covers. Guidelines for removal of the left side panel is below:

1. Open the left saddlebag lid as shown.
 - Repeat on the right side.

<Left side>

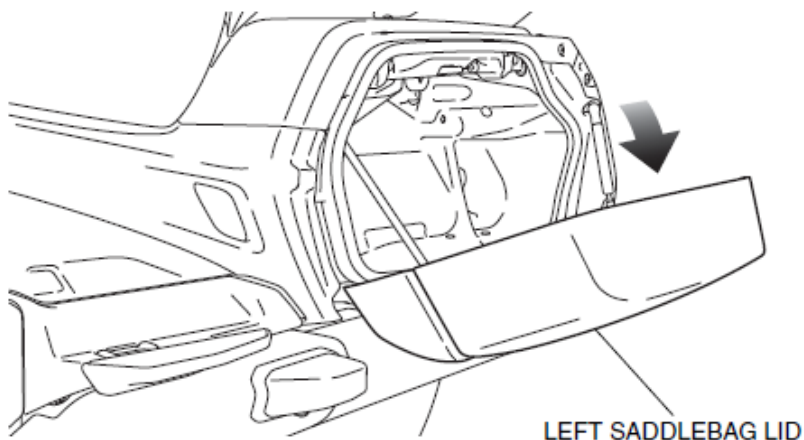

2. Remove the left side cover as shown, and disconnect the negative (-) cable of the battery.

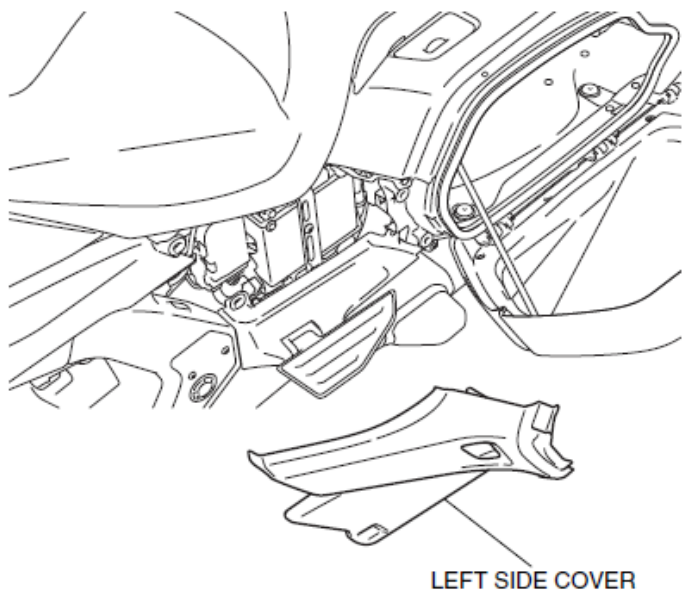

Bike Disassembly

3. Remove the right side cover in the same manner as the left side.
4. Remove the seat as shown.

Note: Disconnect the connector for GL1800/D/DA

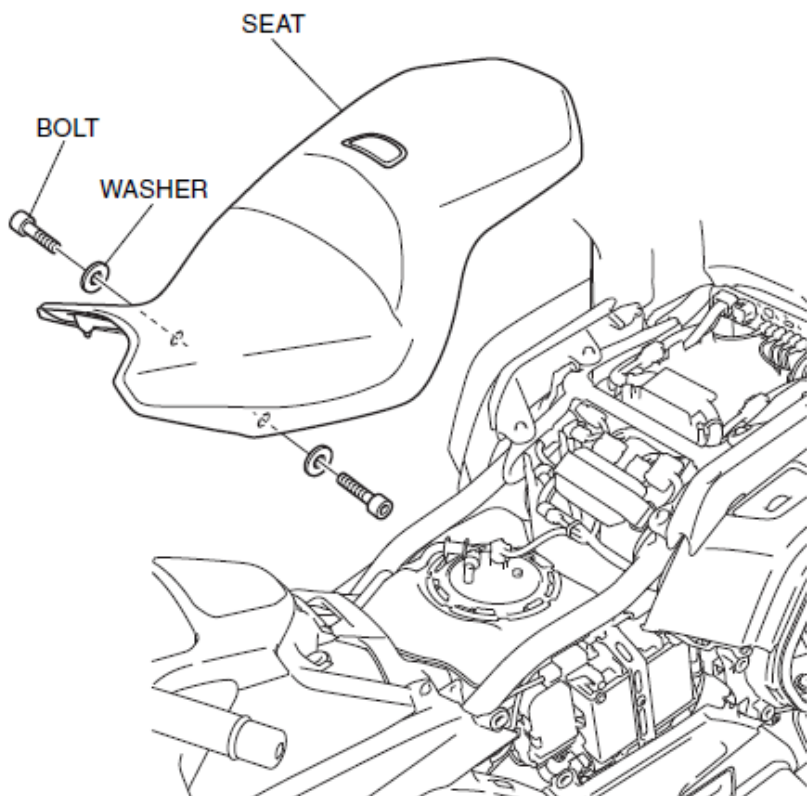

Bike Disassembly

5. Fold down the left rear view mirror backward as shown.

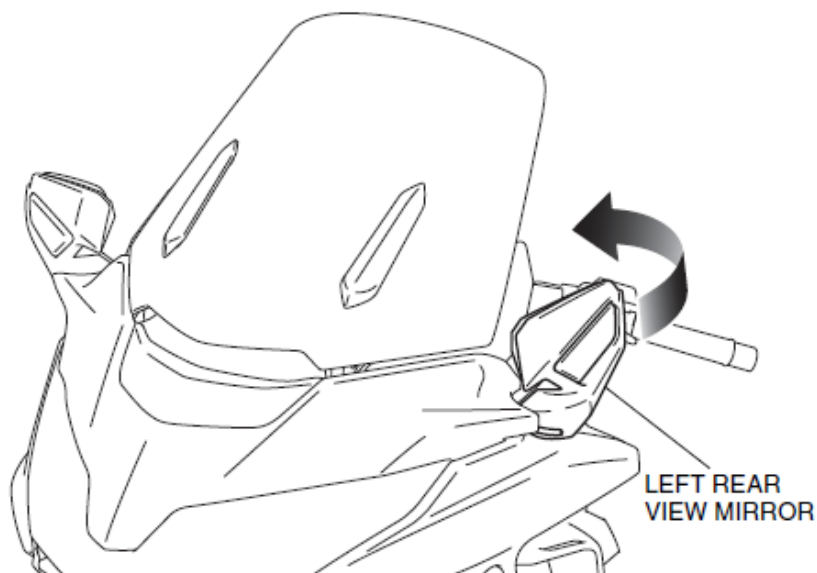

6. Remove the left mirror arm panel as shown.

<Left side>

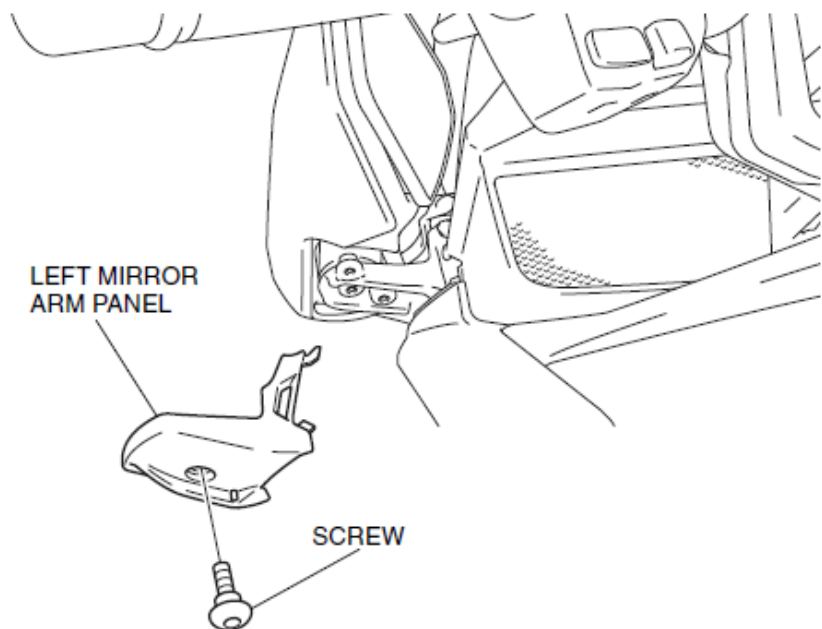

Bike Disassembly

7. Remove the left rear view mirror as shown.

LEFT REAR VIEW MIRROR
Disconnect the connector.

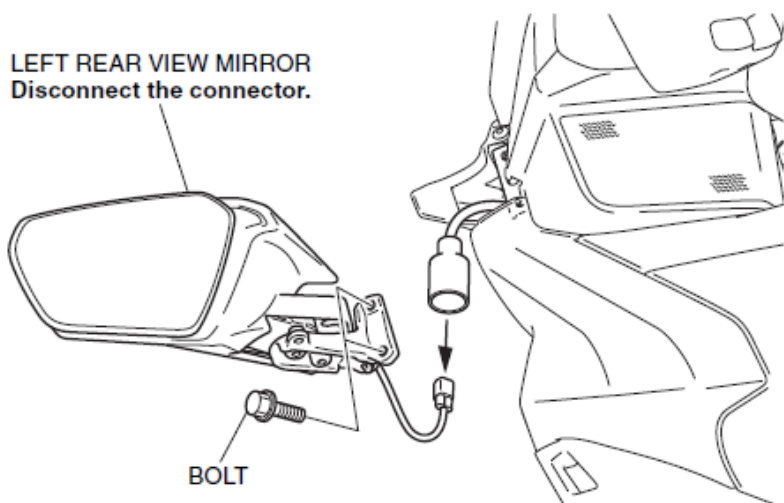

8. Remove the right mirror arm panel and right rear view mirror in the same manner as the left side.
9. Remove the screw as shown.
- Repeat on the right side.

<Left side>

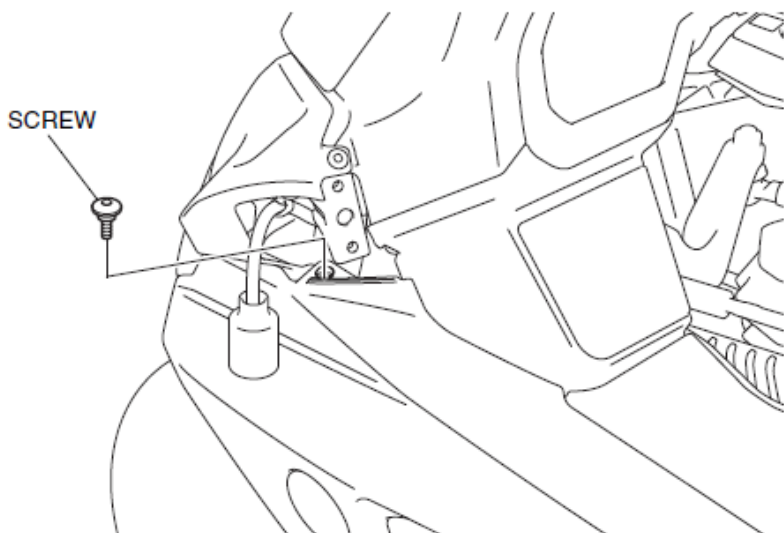

Bike Disassembly

10. Remove the left deflector panel as shown.

<Left side>

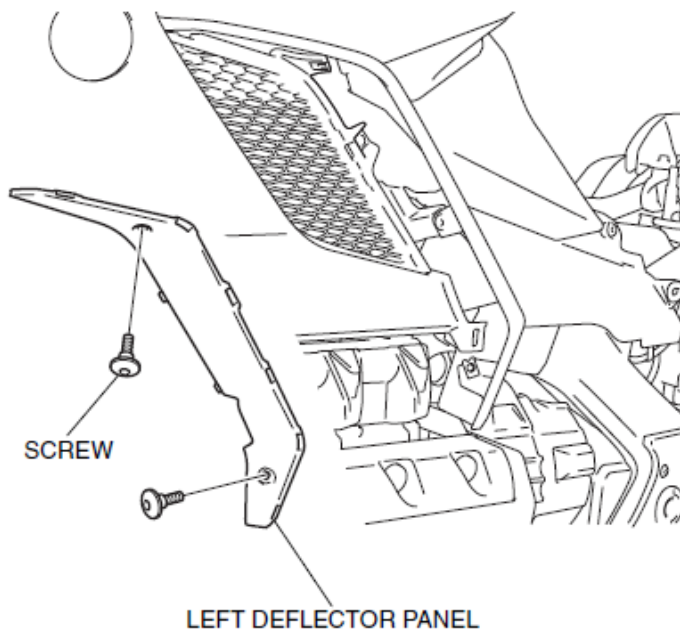

11. Remove the clip as shown.

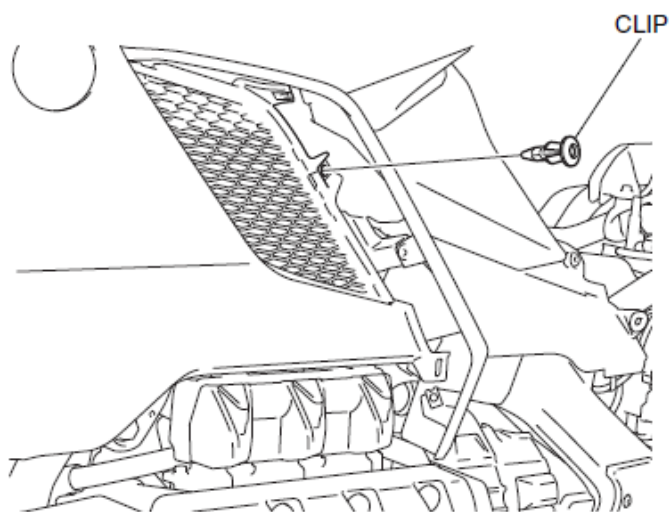

Bike Disassembly

12. Remove the left inner cowl as shown.

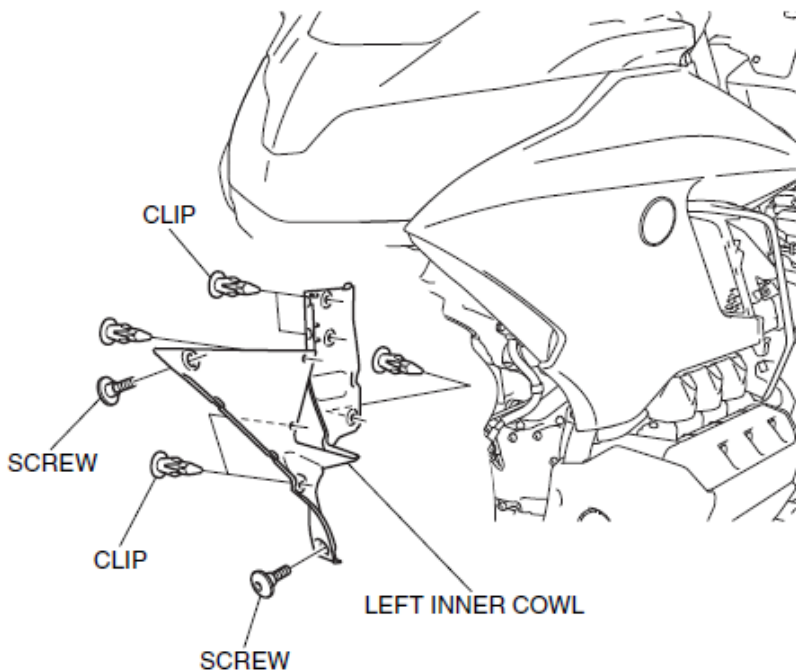

13. Remove the clip as shown.

<Left side>

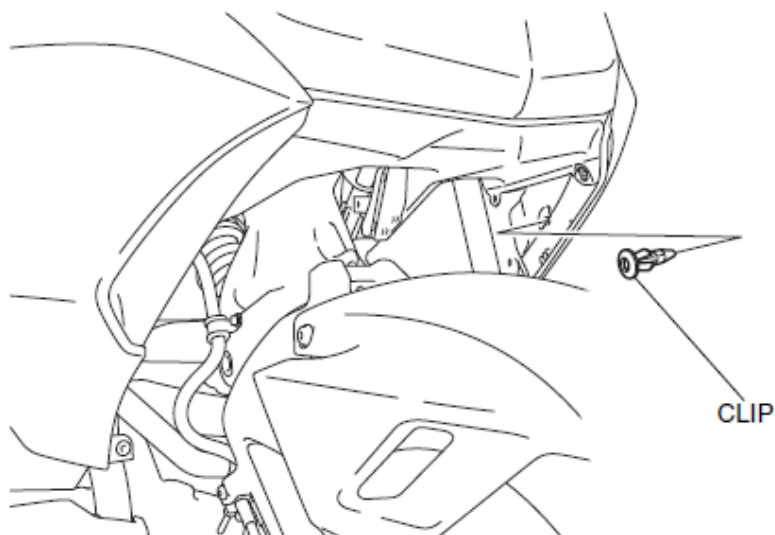

14. The left side panel can be gently pulled away from the bike and removed.

Mounting the Harness

Once the left side fairing has been removed, access to the headlight connector and location for mounting the harness can be obtained. A detailed photo of the exact harness location can be found on the next page. Mount the harness in a location behind and above the headlight, along the centerline of the bike. Make sure wires are dressed neatly and secured with zip-ties away from pinch points and direct heat.

Route the power wires from the harness toward the battery in the path shown above. It may be useful to use a wire pull tool for this task.



Wiring

To utilize the switched hot, highbeam and horn functions of your Clearwater Lights, use the provided Posi-Taps to tap into the corresponding wires at the headlight connector and horn respectively. Reference the overview wiring diagram on Page 2 for an overview.

Switched Hot: Use a Posi-Tap to tap the red wire from the Clearwater Lights Harness to the Blue with Black Stripe wire at the headlight connector.

Highbeam: Use a Posi-Tap to tap one of the white wires from the Clearwater Lights Harness to the Solid Blue wire at the headlight connector.

Horn: Posi-Tap the other white wire from the Clearwater Lights harness to the hot wire of the horn. The horn is located on the left side of the bike, next to the factory AUX fog light.

Harness Location



Horn Location



Dimmer + Switch Installation

Mounting Dimmer Control and Switch:

Mount the dimmer to the handlebar cluster using the supplied L bracket, two spacers, flat washer and bolt stackup. The M6 x 10 BH will thread into the dimmer box through the L bracket. Reference photos below.

Try to route wires from lights and volume control knob along pre-existing wires.

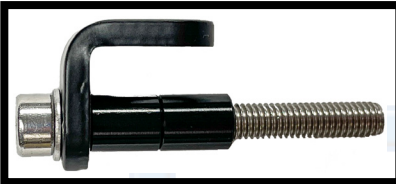

Stackup of hardware for mounting dimmer box to control cluster on handlebars using the M5 x 45 SH.



Dimmer and switch mounting location

Mount the switch to the adjacent faster utilizing the M5 x 35 SH bolt and spacer.



NOTE: Make sure the dimmer and switch connections to the harness are securely fastened. The lights will not turn on without the switch connected.

Mounting the Lights

Removal of the original mirror covers is required, they will be replaced with modified ones included in this kit. Once the original covers are removed, three fasteners will be exposed. Assemble the mirror mount and modified cover. The bracket should easily fall into place and will align with the three fastener points. Follow the exploded diagram below for complete installation.

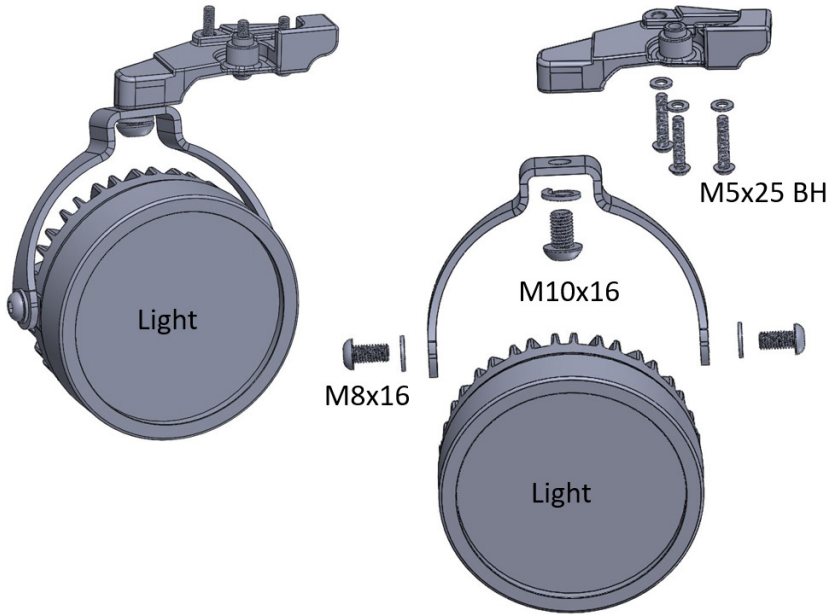

Modified Mirror Cover



Bike Right Side



Bike Left Side

Light Alignment & Tips

Light Alignment:

Ask an assistant to help you with this procedure. Make sure the bike is on level ground and have an assistant sit on the bike. Press a level against the face of the light, and adjust its angle.

The goal is to adjust the lights so that the light is level with the ground.

Passengers and luggage may alter the alignment of the light, so further adjustments may be needed. You may find that a slight downward angle (5 degrees) is helpful.



Do Not Kink The Grommet

To maintain the integrity of the water sealling grommet, do not kink, deform or put pressure on the grommet when dressing the wires during install of Clearwater Lights.

Do Not Kink The Grommet

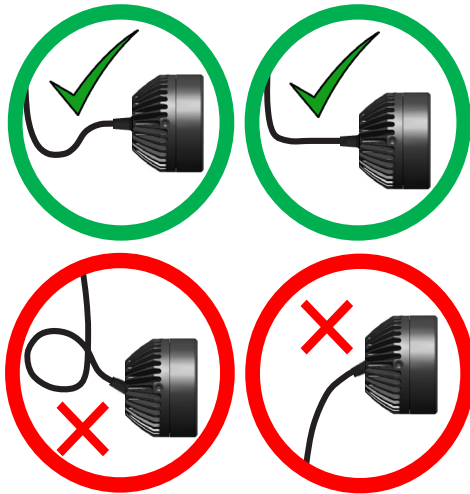

Congratulations!

Congratulations! You have finished the install of Clearwater Lights to the mirror mounts on a Honda Goldwing! Get out and ride!

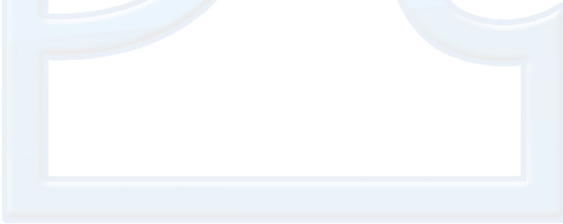

Thank you for purchasing your **Clearwater Lights**. We hope this product will help make you a safer rider. Please feel free to send us comments or suggestions at any time. We learn from you. Visit our website for more exciting products to help you see better at night.

Ride safe!

Sincerely,

Glenn and the team at Clearwater.



The Clearwater Company - 11305 Sunrise Gold Circle, Suite D
Rancho Cordova, CA 95742
Phone: (916) 852-7029 | Fax: (916) 852-9410 | www.clearwaterlights.com

Revised 7/28/2022