

The logo features a blue square frame containing a stylized blue wave graphic that flows from the top left towards the bottom right.

clearwater LIGHTS™



Installation Manual

BMW F750 & F850

Darla LED Light Kit

Dimmable

Patent Pending









Parts List - Beak Mount (GS Only)

Please be sure to read our instructions thoroughly before attempting installation.

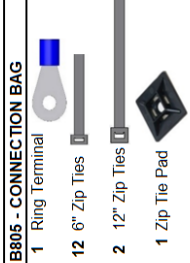
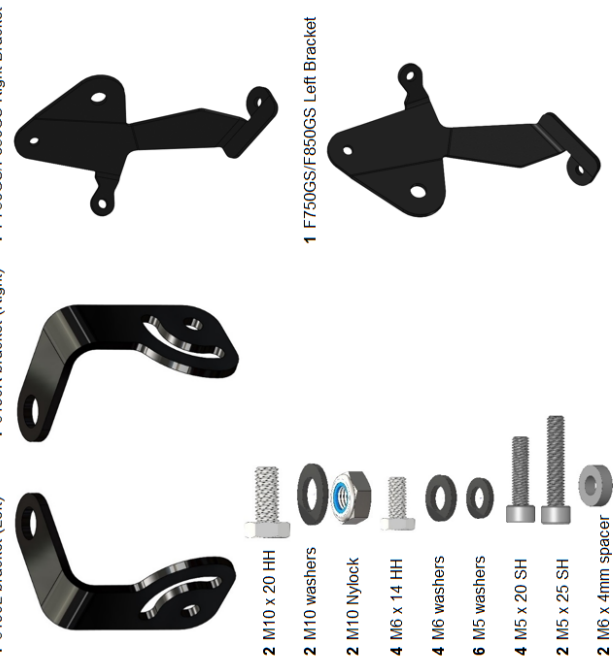
- Check Parts list below with your kit to be sure all parts are handy. If something is missing, please call us at (916) 852-7029.

D-136 Beak Mount Kit for F750 GS and F850 GS Only (NO GSA)

<p>B764 - CANOPENER HARNESS BAG</p> <p>1 Harness + Fuse + Fuse Holder</p> 	<p>B713 - CAN3 BAG</p> <p>1 CAN-Opener</p> 	<p>B805 - CONNECTION BAG</p> <p>1 Ring Terminal</p> <p>12 6" Zip Ties</p> <p>2 12" Zip Ties</p> <p>1 Zip Tie Pad</p> 	<p>B-236 HARDWARE BAG</p> <p>1 619cL bracket (Left)</p> <p>1 619cR bracket (Right)</p> <p>1 F750GS/F850GS Right Bracket</p> <p>1 F750GS/F850GS Left Bracket</p> 
<p>2 Light Assembly</p> 			
<p>2 M10 x 20 HH</p> <p>2 M10 washers</p> <p>2 M10 Nylock</p> <p>4 M6 x 14 HH</p> <p>4 M6 washers</p> <p>6 M5 washers</p> <p>4 M5 x 20 SH</p> <p>2 M5 x 25 SH</p> <p>2 M6 x 4mm spacer</p> 			
<p>2 1 ft Extension</p> <p>Last Updated: 1/25/21</p> 			

Parts List - Fender Mount (F850 Only)

Please be sure to read our instructions thoroughly before attempting installation.

- Check Parts list below with your kit to be sure all parts are handy. If something is missing, please call us at (916) 852-7029.

D-138 Fender Mount for F850GS/GSA only (Not for 750)



2 Light Assembly



B764 - CAN opener HARNESS BAG
1 Harness + Fuse + Fuse Holder

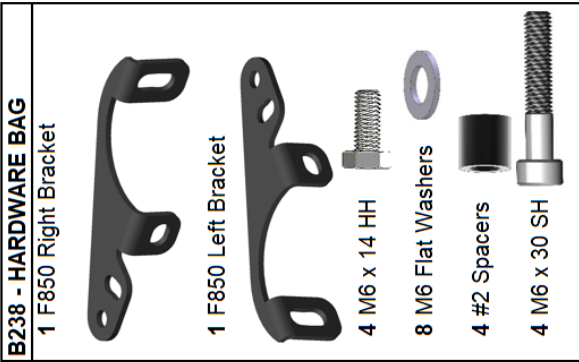

B238 - HARDWARE BAG
1 F850 Right Bracket
1 F850 Left Bracket
4 M6 x 14 HH
8 M6 Flat Washers
4 #2 Spacers
4 M6 x 30 SH

Last Updated: 1/25/21



B713 - CAN3 BAG
1 CAN-Opener

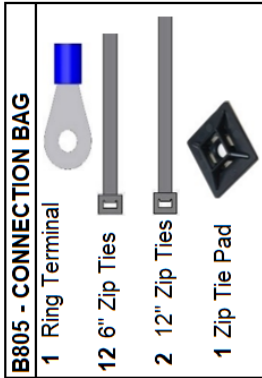

B805 - CONNECTION BAG
1 Ring Terminal
12 6" Zip Ties
2 12" Zip Ties
1 Zip Tie Pad



2 1 ft Extension

Bike Preparation & Fender Mount

Bike Preparation:

- First, park the motorcycle on hard pavement or concrete to insure the bike will be stable during the installation. If you can mount the bike on a stand with tie-down straps, this will help secure the motorcycle.
- Follow the manufacturers guidelines for disconnecting the battery. This is important to prevent damage to the electrical system.

Installation Tips:

There are two main parts to the installation of your new Clearwater Lights. The mechanical portion, and the electrical portion. With this manual, we will go over the basics of both which should allow you to get your lights up and running. If you purchased a bracket made specifically for your bike, refer to our manuals online for that specific installation at:

www.clearwaterlights.com

Note: Motorcycle needs to be turned on before the lights will function.

Mounting The Lights Fender Mount



F750 Fender Mount - D50 Kit

F750 Fork Mount - D50 Kit Exploded Diagram



Note: This is the only Darla fork kit available for the F750.



Mounting The Lights - Beak Mount



D136

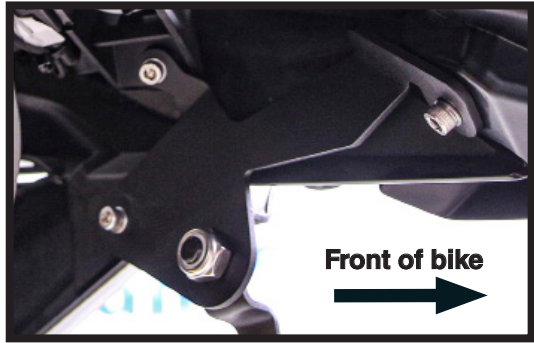

Left Side Assembly View From Outside the Bike

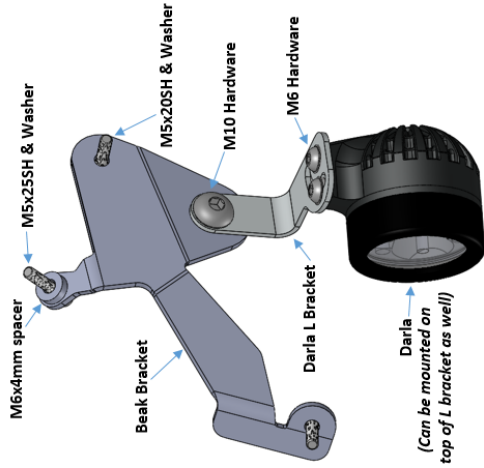

Left Side Assembly View From Under the Fender

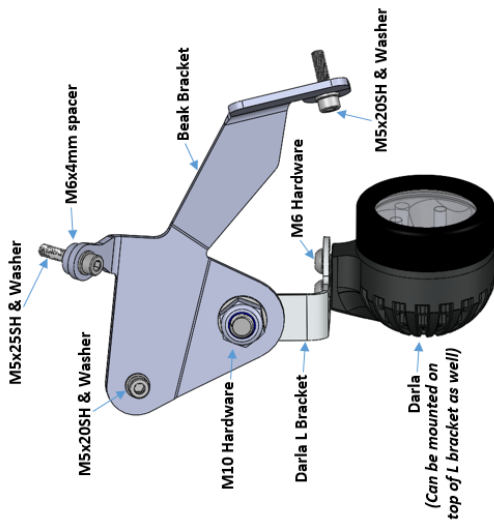

Wiring Diagram

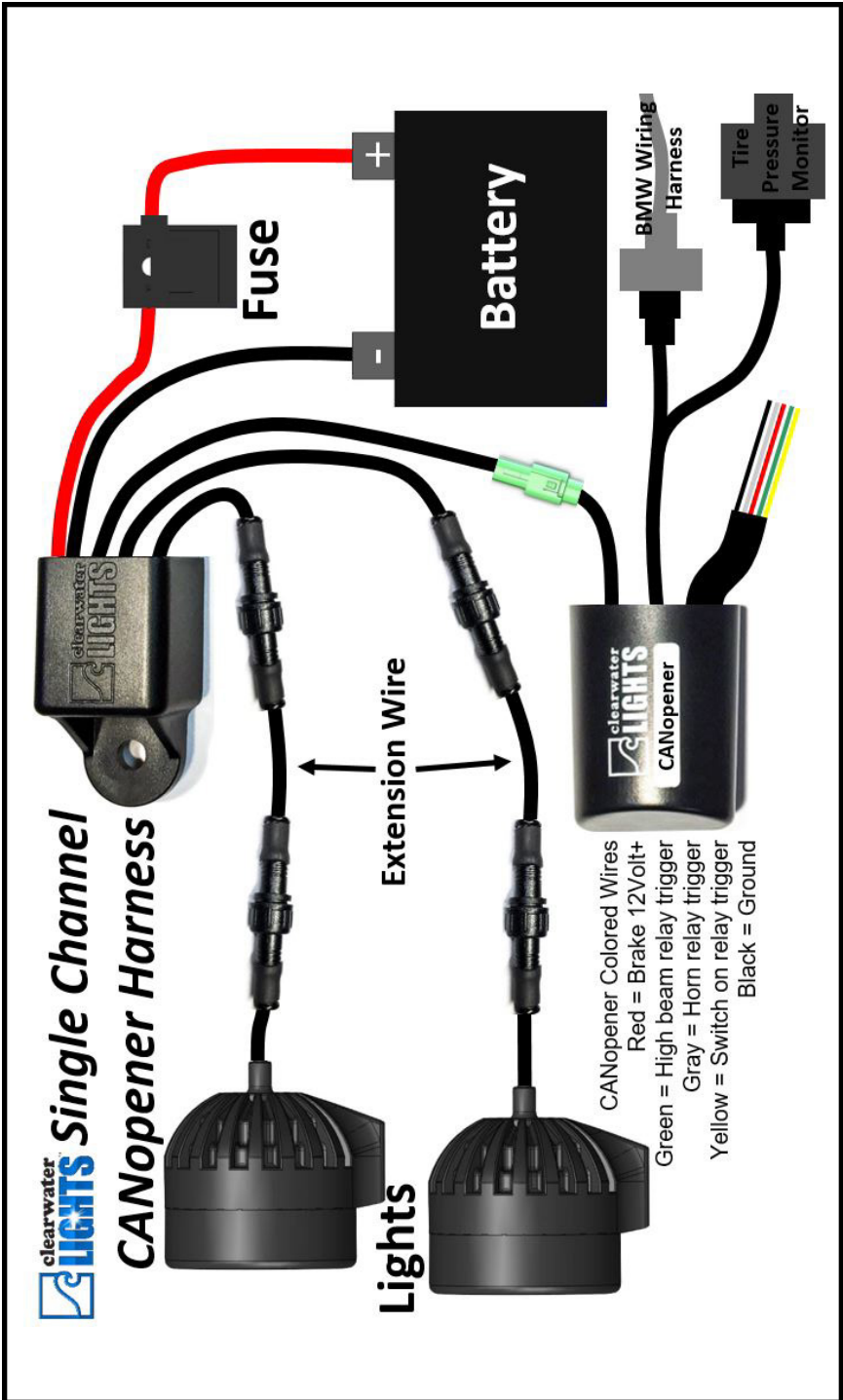

Disassembly & Wire Routing

1. Park the motorcycle on hard, flat pavement or concrete to ensure the bike will be stable during installation. Utilize a center stand if possible.

2. Follow the manufacturer's guidelines for removing the seat, and disconnecting the negative terminal on the battery. Remove the center gas tank cover (NOT THE GAS TANK) and the top and rear bolts of the left side fairing so it can be pulled slightly away from the tank for routing wires.

3. The harness mounts just behind the fork in the front of the bike.

4. Connect the CANopener to the Tire Pressure Monitor (TPM), located under the REAR SEAT. TPM is circled in red in photo below and plug the bikes' TPM connector back into the CANopener. Plug the green connector from the harness into the green connector on the CANopener. Use the Green Connector Extension. Reference wiring diagram.

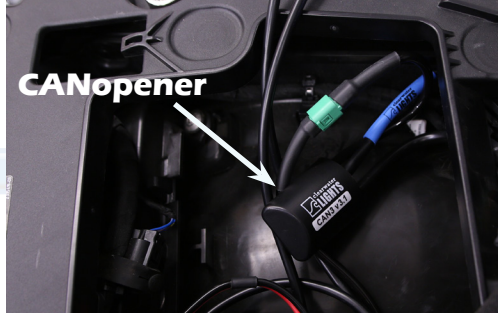

Wire Routing

5. Power wires from the harness should be routed along the left side, so that the ends are just in front of the battery. The battery wires can be shortened so that the wires lay neatly to the battery terminals. Do not connect the battery yet.

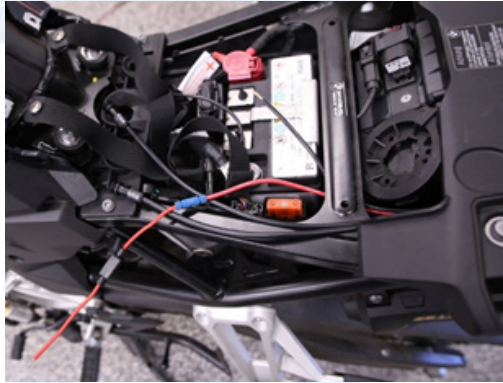

6. FOR BEAK MOUNT: utilizes the existing mount points for the front fender. However, use the hardware provided in your Clearwater Lights kit for fastening the bracket in place. Refer to the exploded diagram for assembly. The longer of the three screws is used at the center/upper most mounting point. The provided spacer is used at this mounting point as well, placing it between the



Alignment & Tips

9. Align and level the lights, on flat ground, with a rider on the bike. Reassemble the tank body work, and side panel fasteners. Connect the battery wires to the terminals, fit the seat back onto the bike. Ensure the bike starts and that the lights operate as expected. Congratulations! You have completed the installation of your Clearwater Lights!

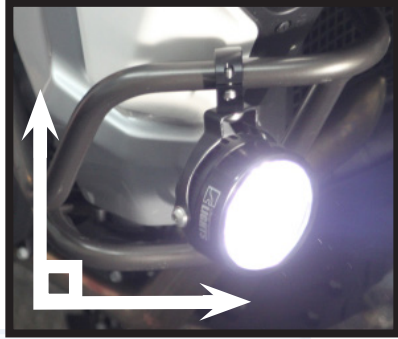

Do Not Kink The Grommet

To maintain the integrity of the water sealling grommet, do not kink, deform or put pressure on the grommet when dressing the wires during install of Clearwater Lights.



Notes



Thank you for purchasing your **Clearwater Lights**. We hope this product will help make you a safer rider. Please feel free to send us comments or suggestions at any time. We learn from you. Visit our website for more exciting products to help you see better at night.

Ride safe!

Sincerely,

Glenn and the team at Clearwater.



clearwater
LIGHTSTM

The Clearwater Company - 11305 Sunrise Gold Circle, Suite D
Rancho Cordova, CA 95742
Phone: (916) 852-7029 | Fax: (916) 852-9410 | www.clearwaterlights.com
Revised 4/9/21