

REVISION HISTORY				
ZONE	REV.	DESCRIPTION	DATE	APPROVED
C8	A	CHANGED TIP FROM A FLAT END TO A .030 RADIUS	4/28/15	JRE

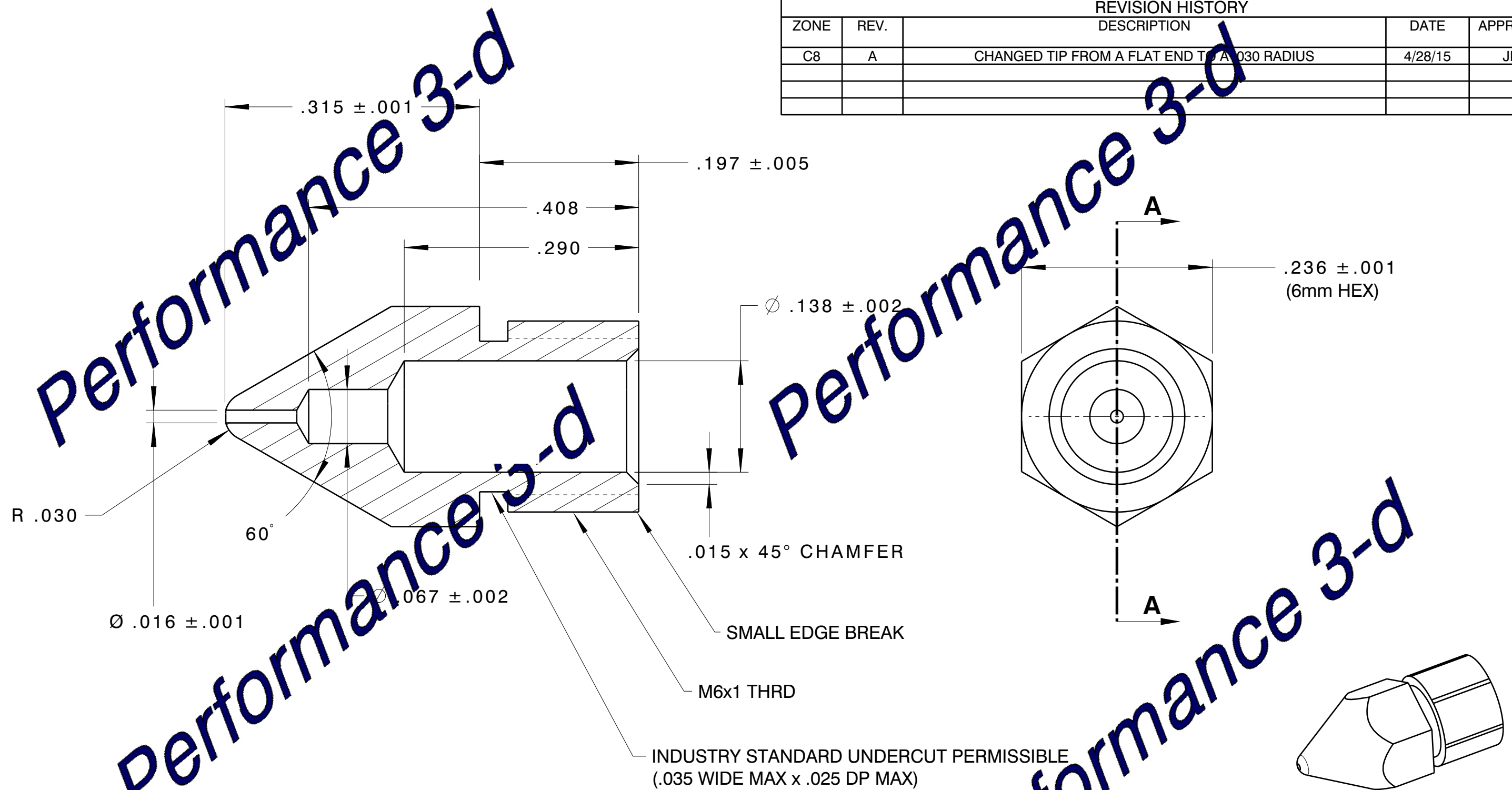

- NOTES:
- INNER FLOWPATH SURFACE FINISH 63 RMS
 - INNER SURFACE FLOWPATH MUST BE FREE FROM BURRS OR SHARP EDGES

MATERIAL	
360 BRASS	
TOLERANCES	
.X = ±.1	X° = ±.25°
.XX = ±.015	(X) = NO IMPLIED TOLERANCE (REFERENCE DIM)
.XXX = ±.005	
XX = ±1/16	
⊕ = ±.002	SURF. FIN = 125
UNLESS OTHERWISE INDICATED	
ALL DIMS IN INCHES (UNLESS SPECIFIED)	
DO NOT SCALE DRAWING	

ENGINEER	JRE	DATE	4-18-15
DRAFTER	JRE	DATE	4-18-15

DWG FILENAME	P3D-Nozzle.CATDrawing
3D MODEL FILENAME:	P3D-Nozzle.CATPart

P3-d
Performance 3-d

DRAWING TITLE: .4mm ZORTRAX NOZZLE
P/N P3D-M200

SIZE	B	WEIGHT (lbs)	N/A	SCALE	8:1	SHEET	1/1
------	---	--------------	-----	-------	-----	-------	-----

REV
A