

REVISION HISTORY				
ZONE	REV.	DESCRIPTION	DATE	APPROVED

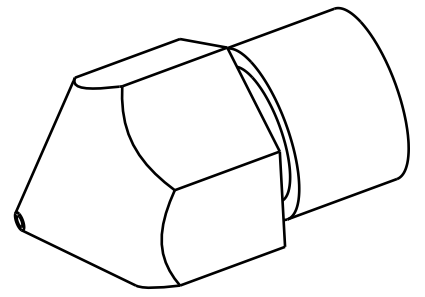
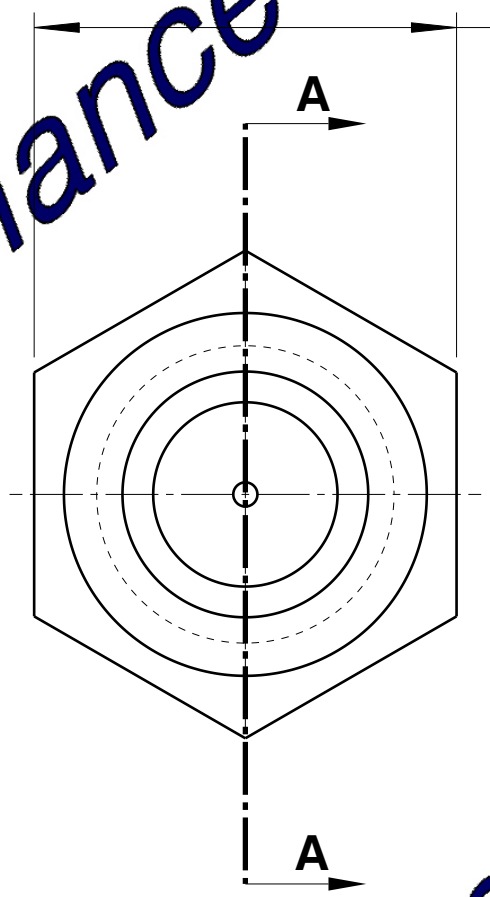
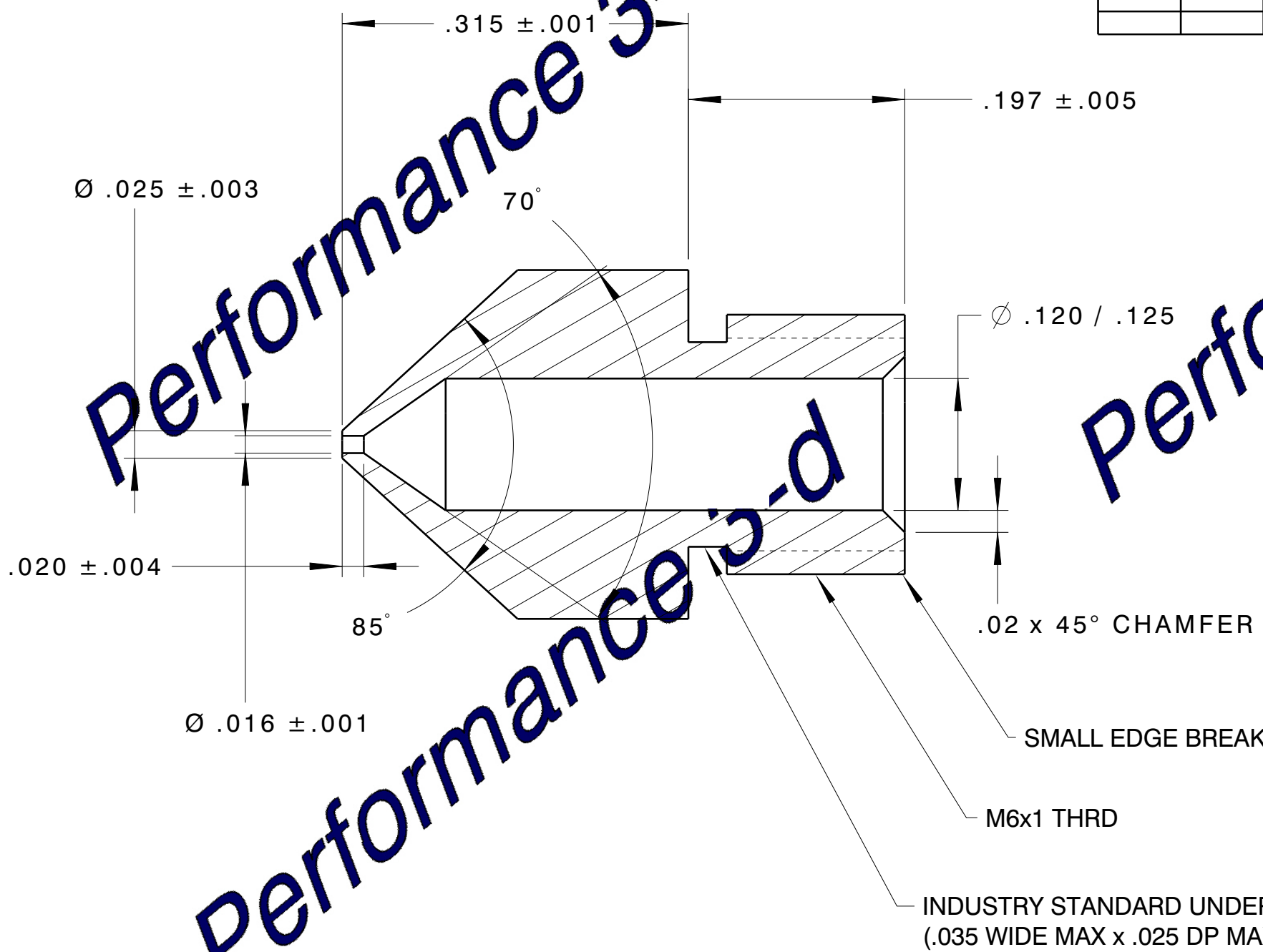

- NOTES:
- INNER FLOWPATH SURFACE FINISH 63 RMS
 - INNER SURFACE FLOWPATH MUST BE FREE FROM BURRS OR SHARP EDGES

MATERIAL	
360 BRASS	
TOLERANCES	
.X = ±.1	X° = ±.25°
.XX = ±.015	(X) = NO IMPLIED TOLERANCE (REFERENCE DIM)
.XXX = ±.005	
XX/ = ±1/16	
⊕ = ±.002	SURF. FIN = 125
UNLESS OTHERWISE INDICATED	
ALL DIMS IN INCHES (UNLESS SPECIFIED)	
DO NOT SCALE DRAWING	

ENGINEER	JRE	DATE	8-14-14
DRAFTER	JRE	DATE	8-14-14

P3-d
Performance 3-d

DRAWING TITLE:		REV
.4mm MK8 FF NOZZLE		N/C
P/N P3D-4N2		
SIZE	WEIGHT (lbs)	SHEET
B	N/A	1/1

DWG FILENAME
P3D-Nozzle.CATDrawing
3D MODEL FILENAME:
P3D-Nozzle.CATPart
ALL INFORMATION CONTAINED HEREIN IS PROPERTY OF PERFORMANCE 3-d LLC AND MAY NOT BE DISSEMINATED OR SHARED WITHOUT WRITTEN CONSENT.