

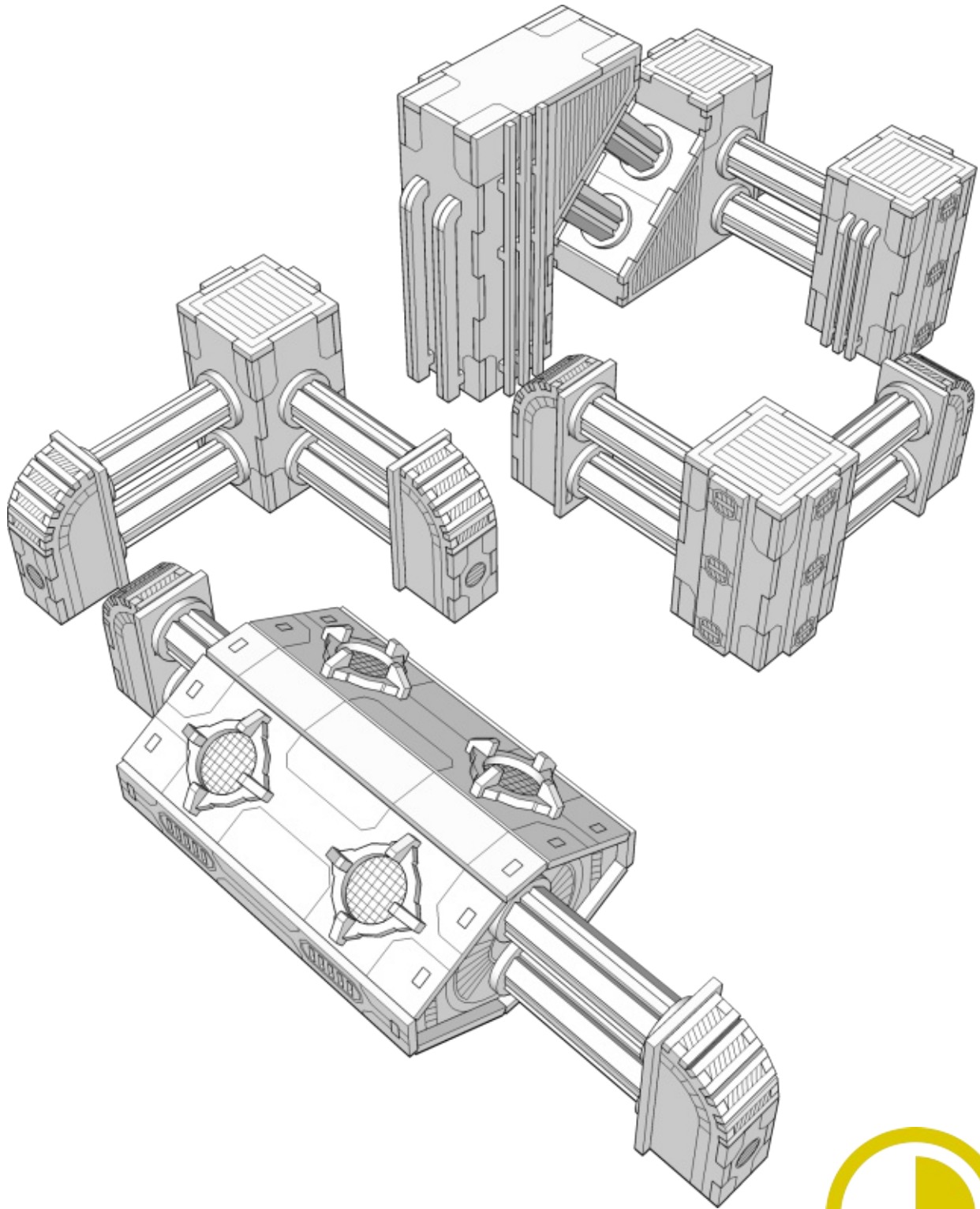

**TABLETOP  
SCENICS**

**TTSC-SFX-079  
Burton  
Quartersections**



**TTCOMBAT**



**1**

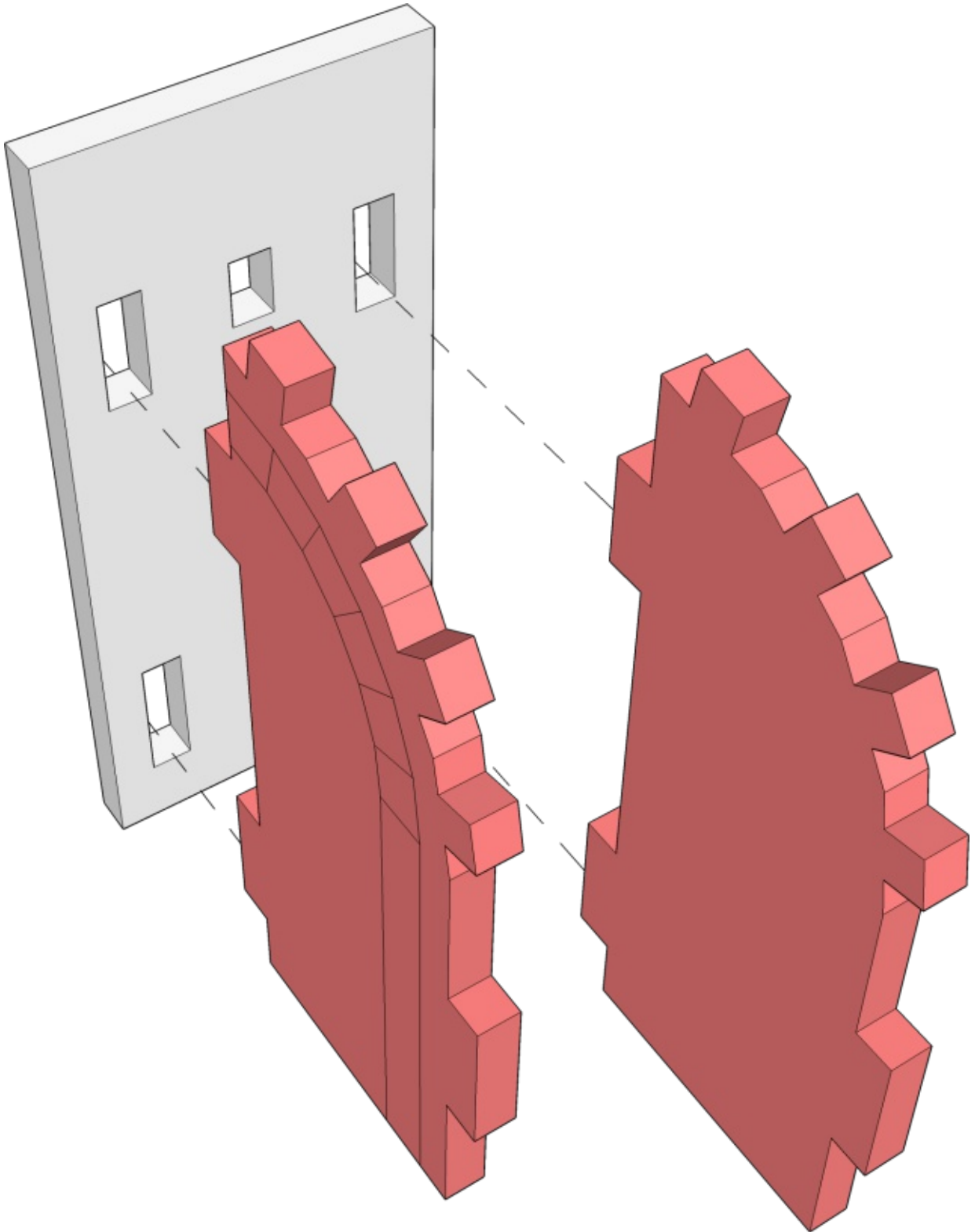

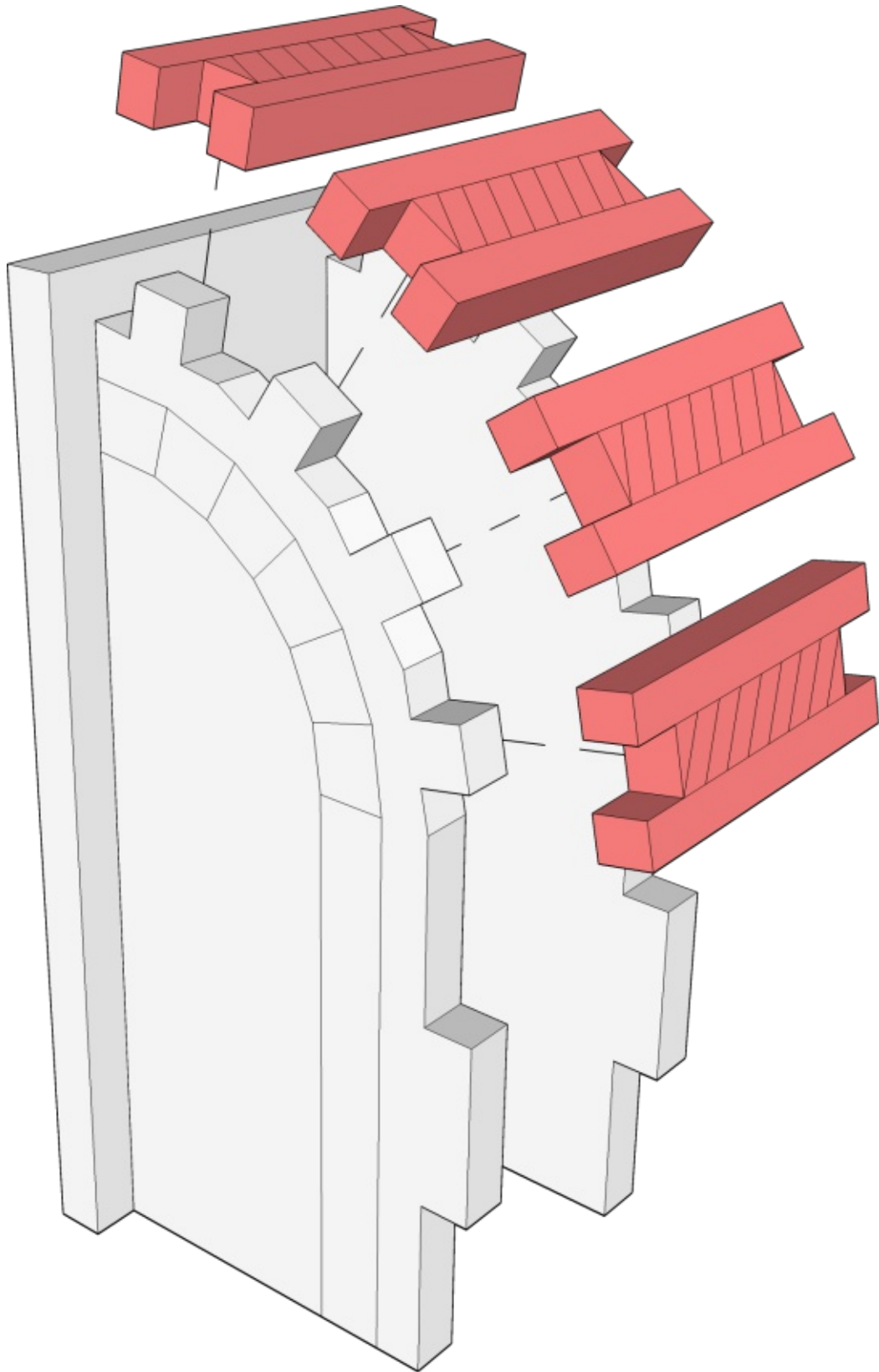



TABLETOP  
**SCENICS**

3

**TTSC-SFX-079**  
**Burton**  
**Quartersections**

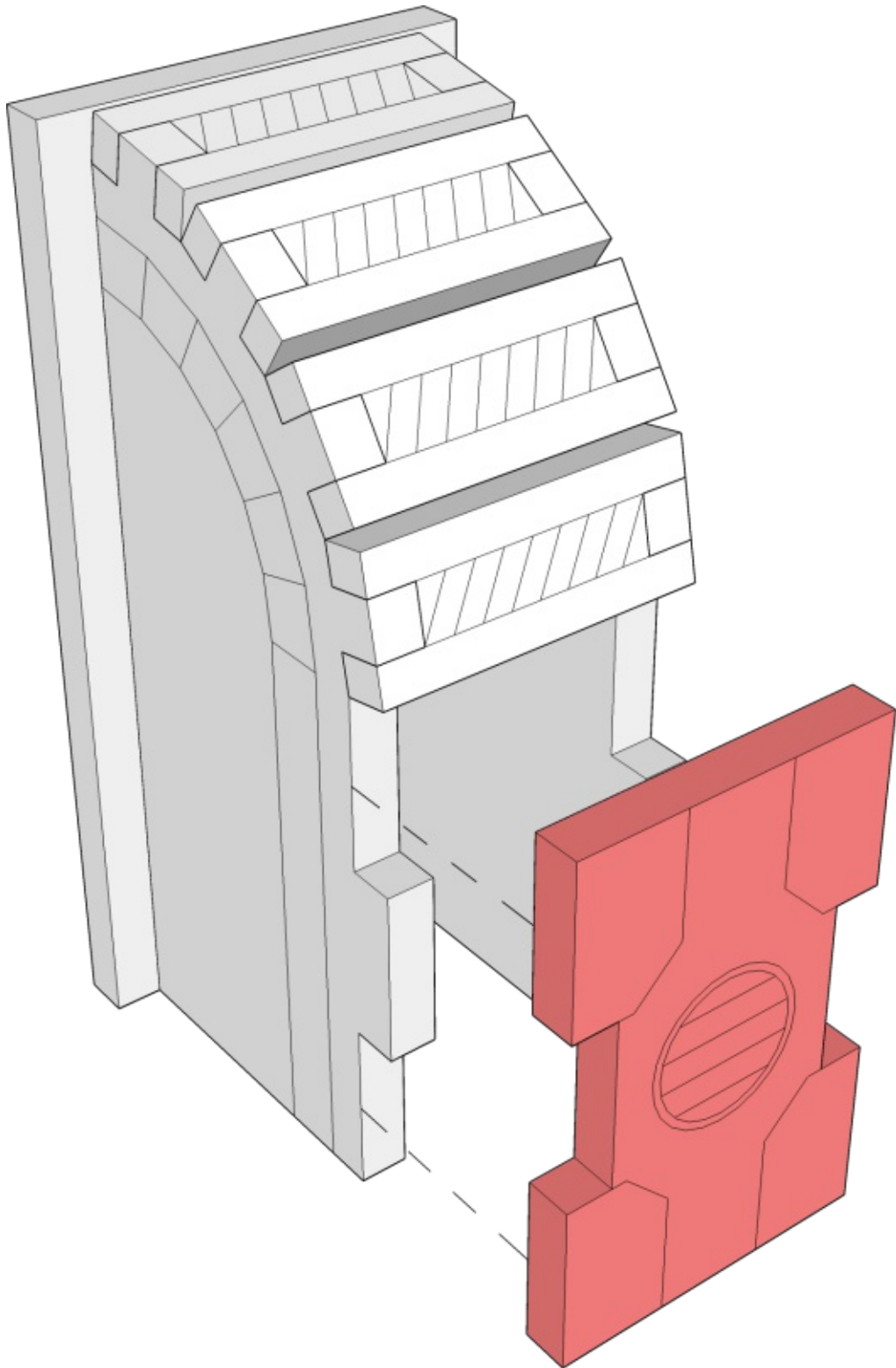



TABLETOP  
**SCENICS**

**TTSC-SFX-079**  
**Burton**  
**Quartersections**

**4**

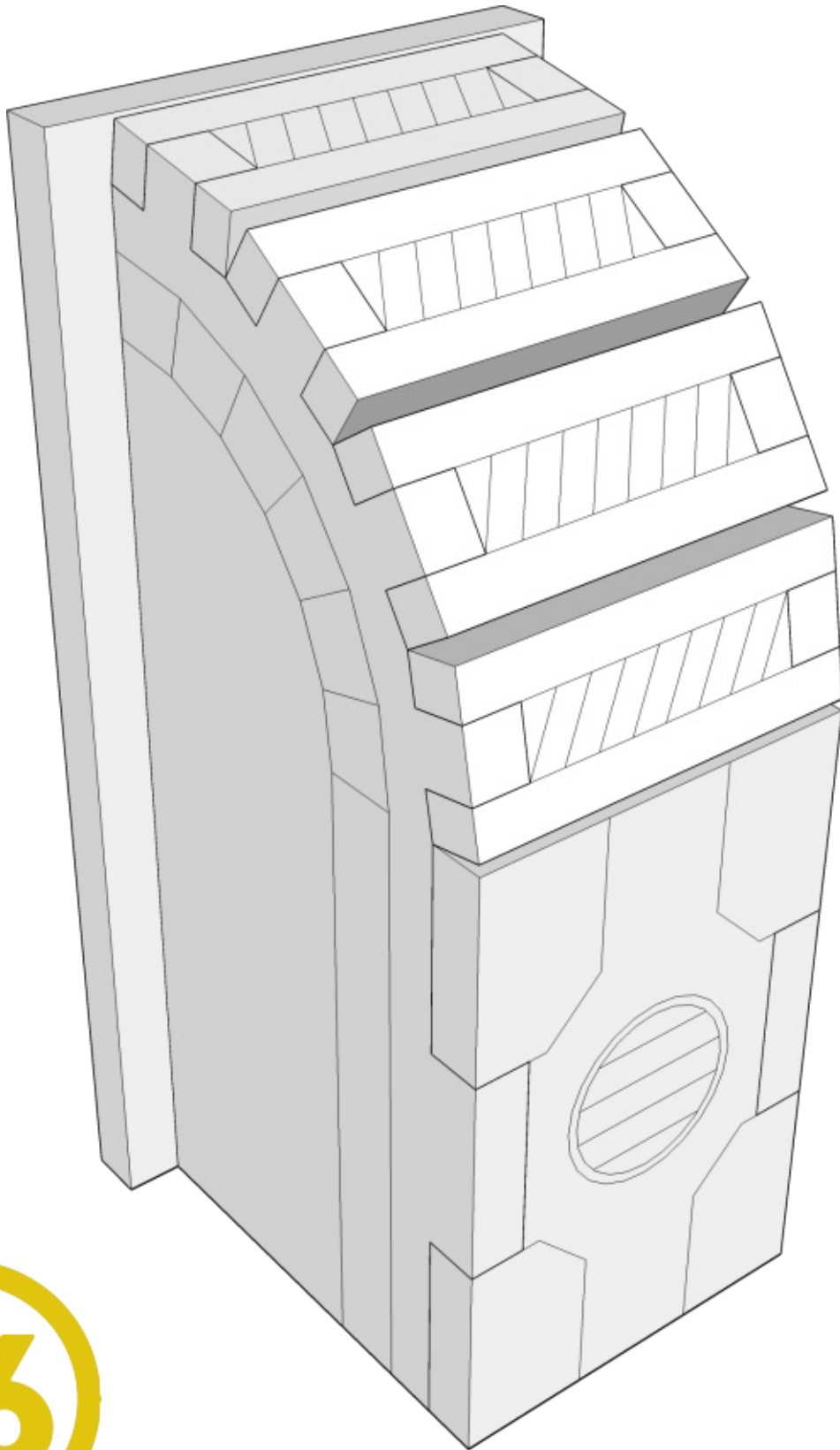

**x6**

 **TTCOMBAT**

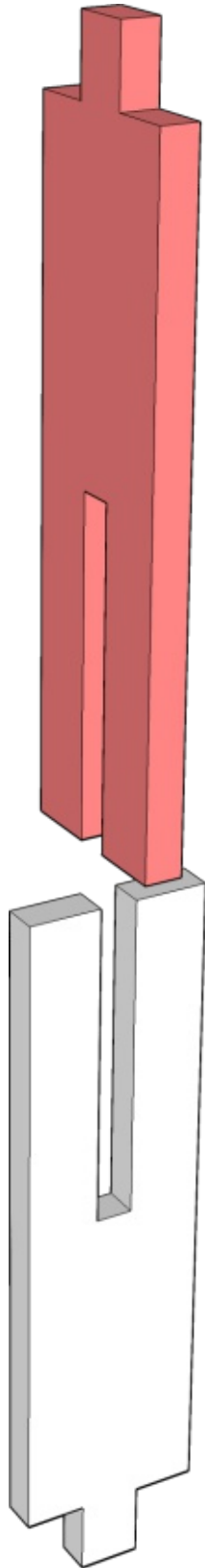

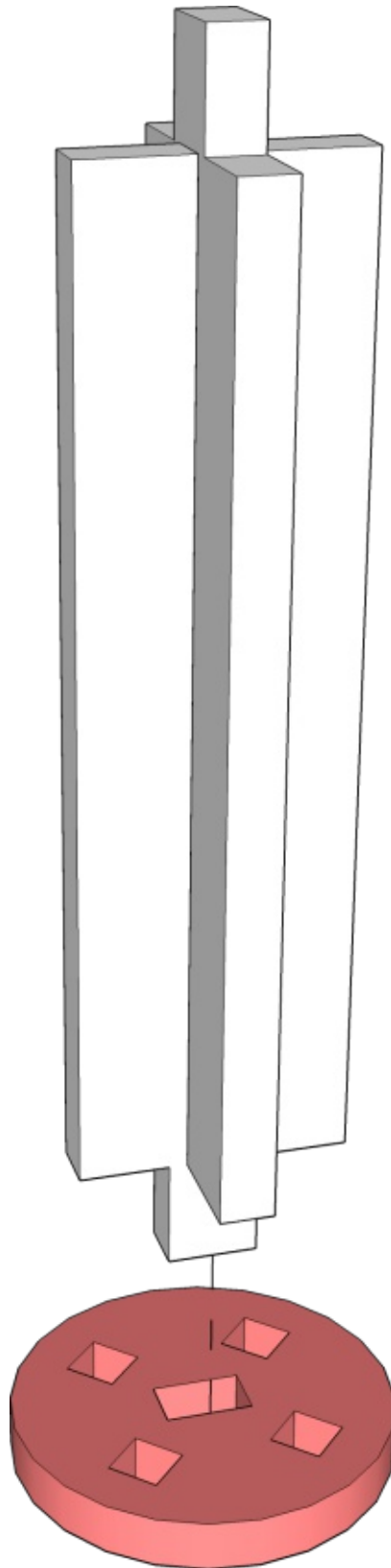



TABLETOP  
**SCENICS**

7

**TTSC-SFX-079**  
**Burton**  
**Quartersections**

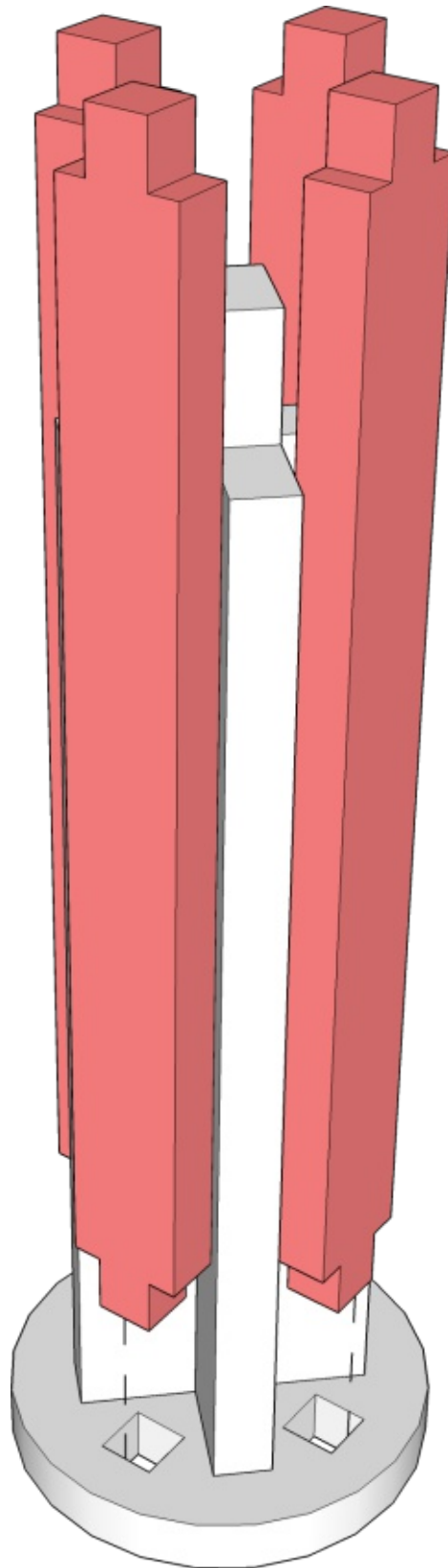

 **TTCOMBAT**



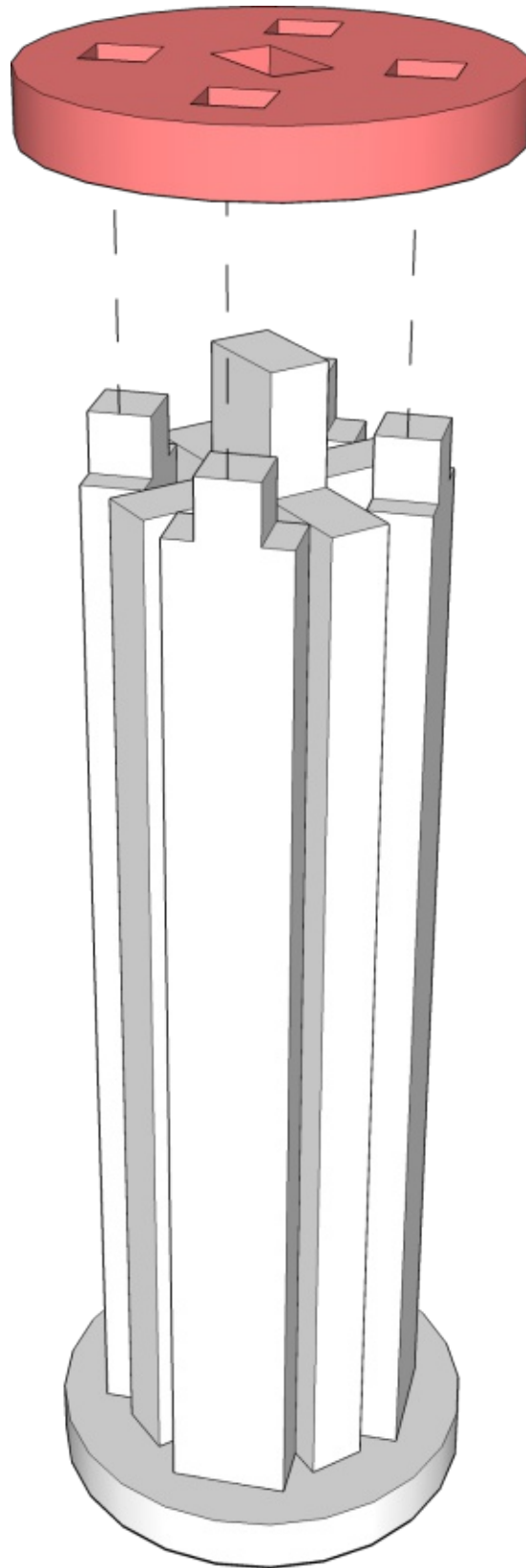



TABLETOP  
**SCENICS**

9

**TTSC-SFX-079**  
**Burton**  
**Quartersections**

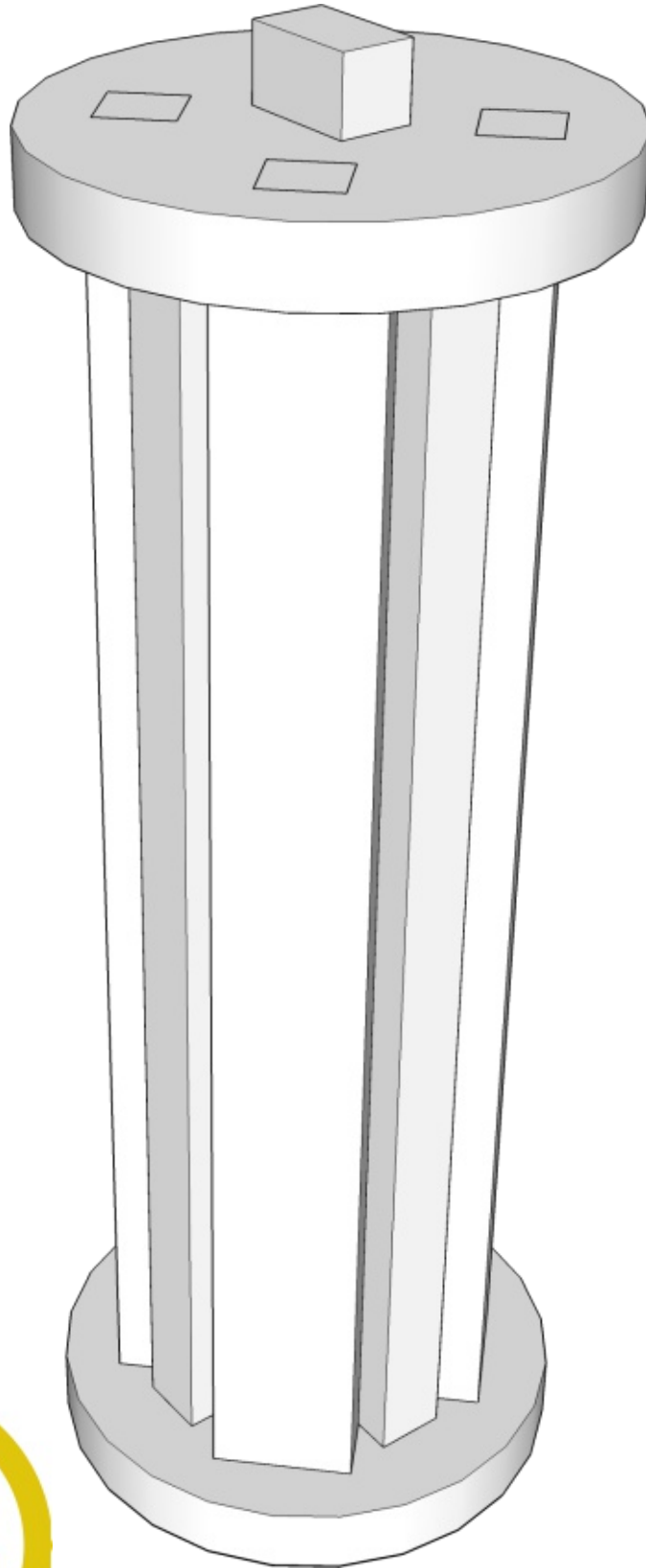

**x14**

 **TTCOMBAT**



TABLETOP  
**SCENICS**

10

**TTSC-SFX-079**  
**Burton**  
**Quartersections**

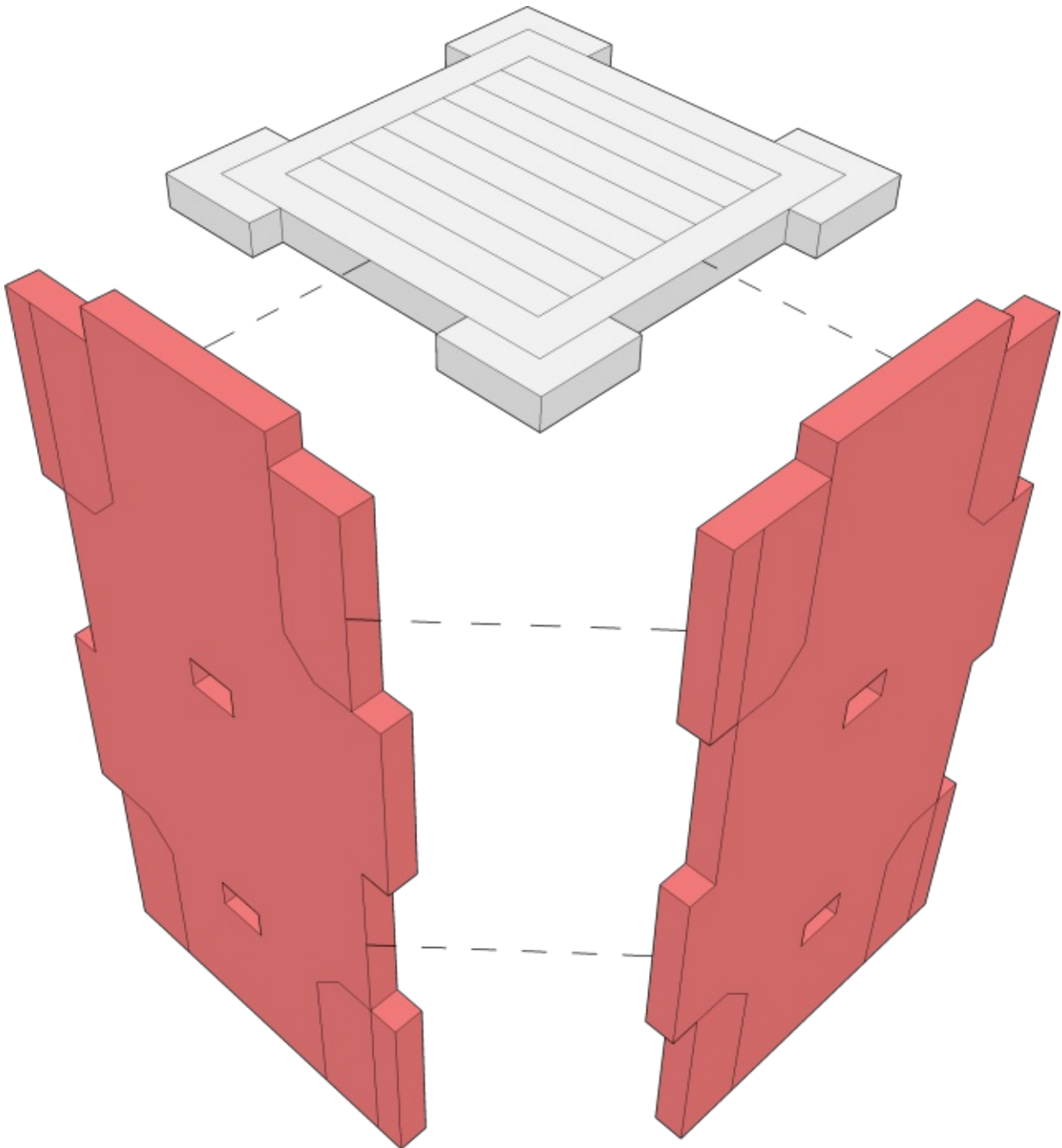

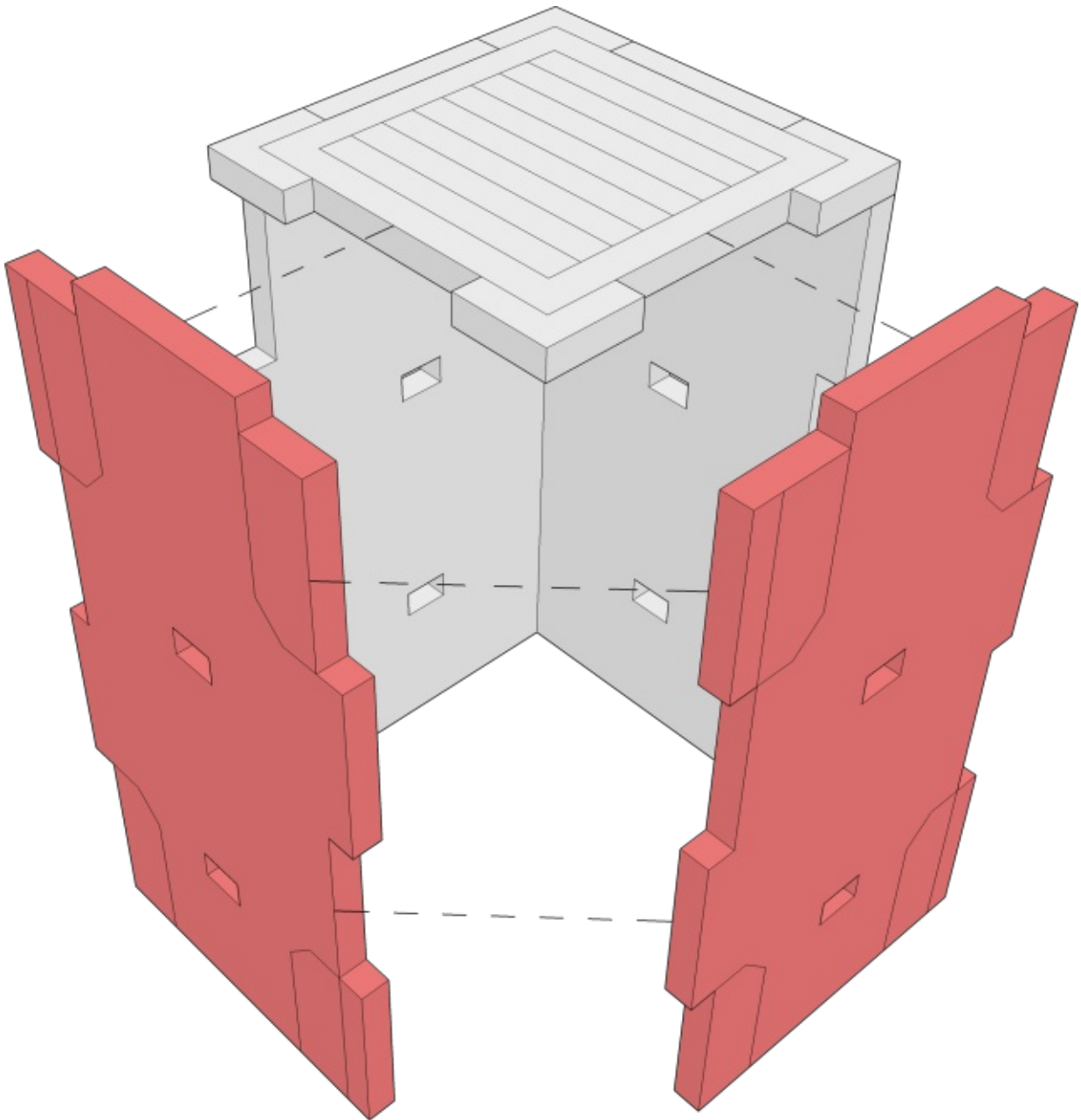



TABLETOP  
**SCENICS**

12

**TTSC-SFX-079**  
**Burton**  
**Quartersections**

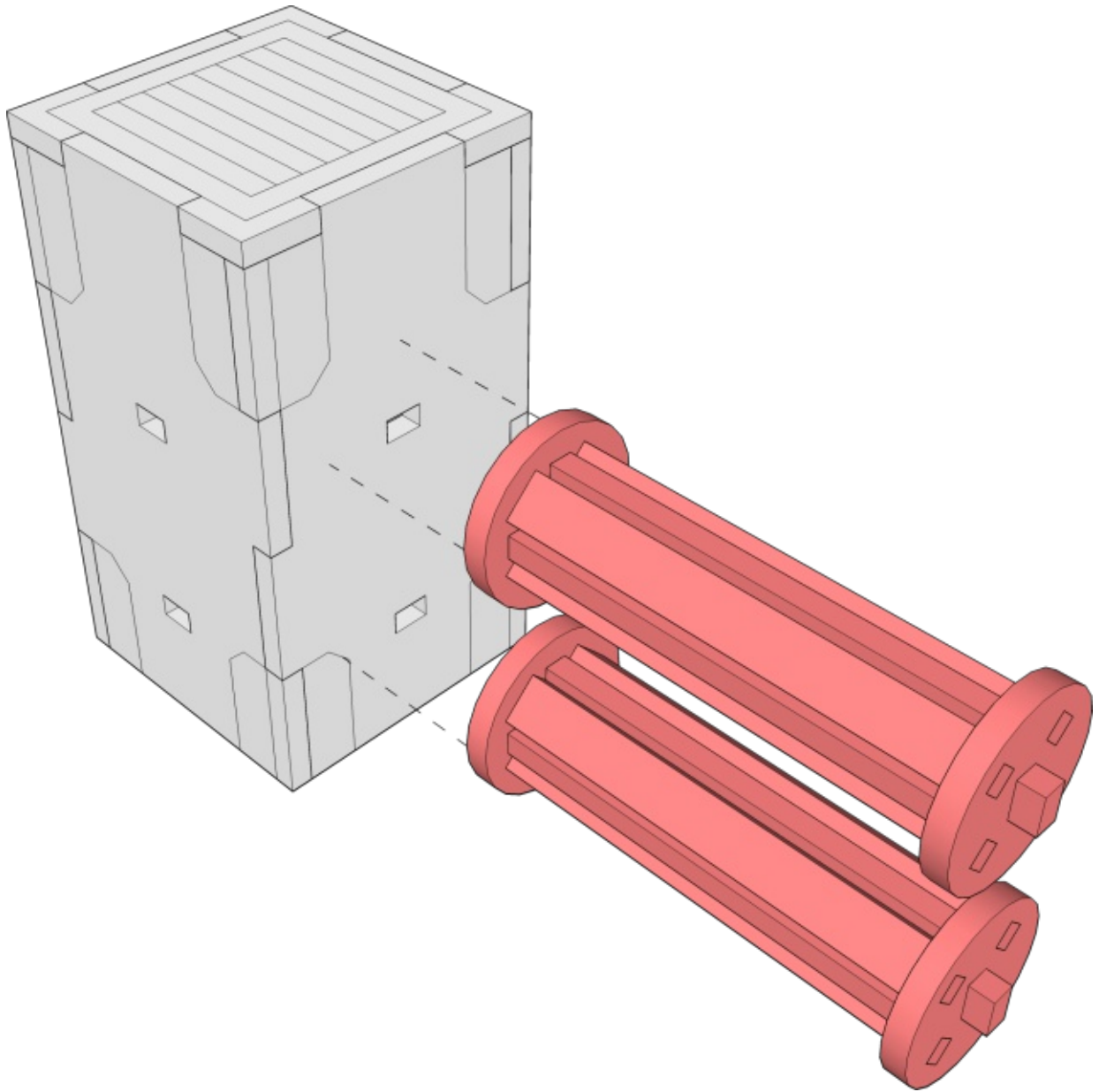



TABLETOP  
**SCENICS**

13

**TTSC-SFX-079**  
**Burton**  
**Quartersections**

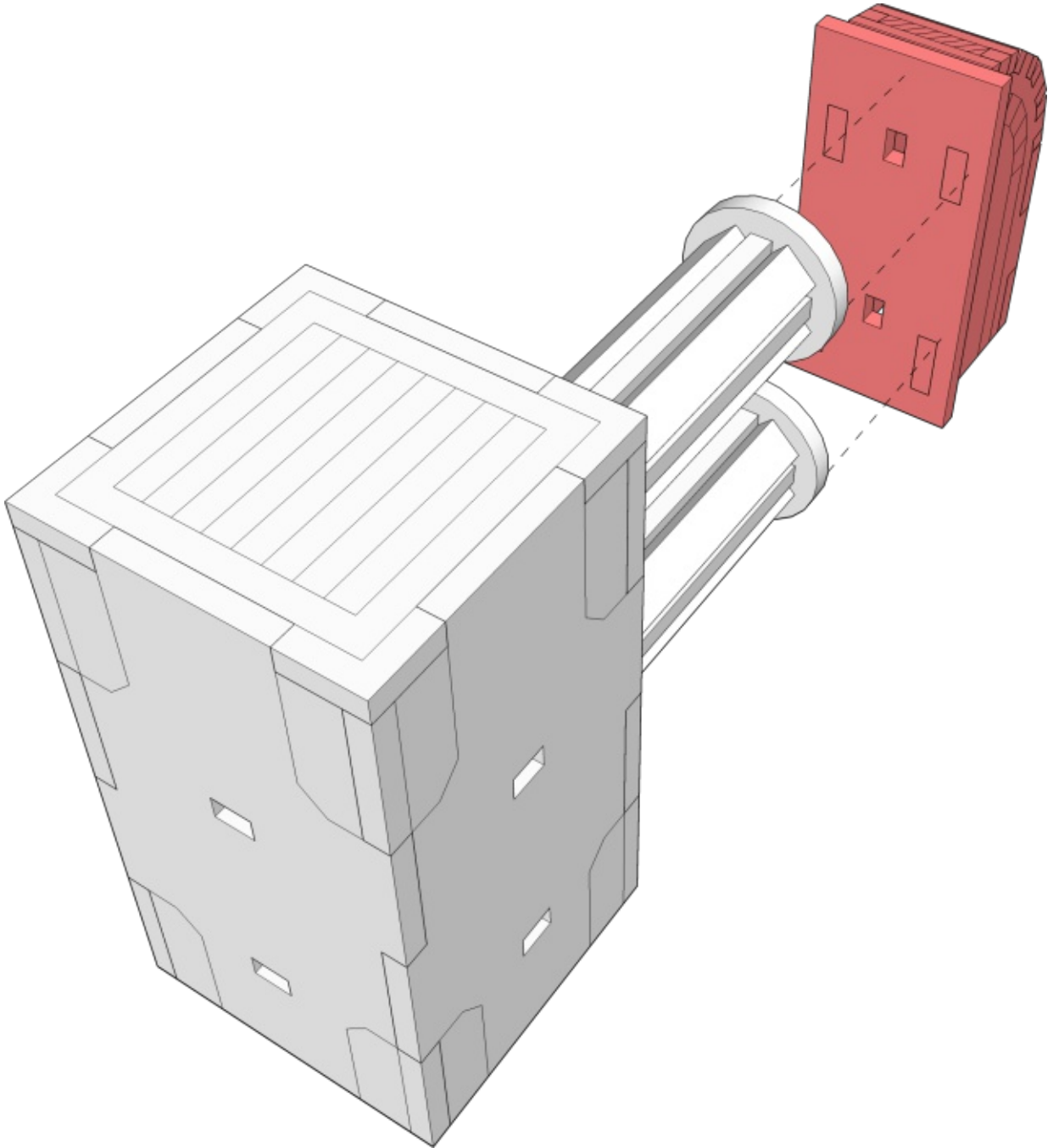



TABLETOP  
**SCENICS**

14

**TTSC-SFX-079**  
**Burton**  
**Quartersections**

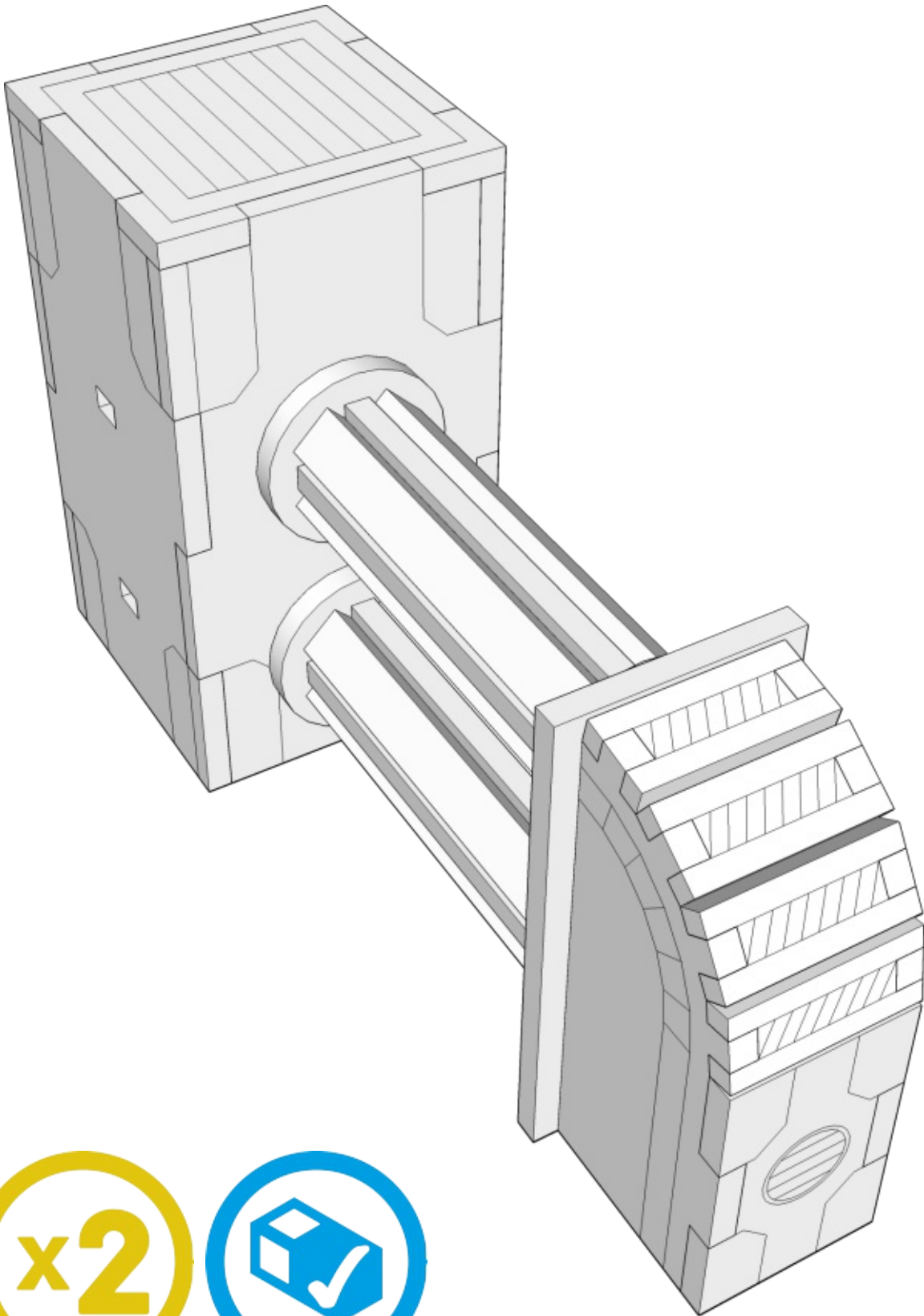

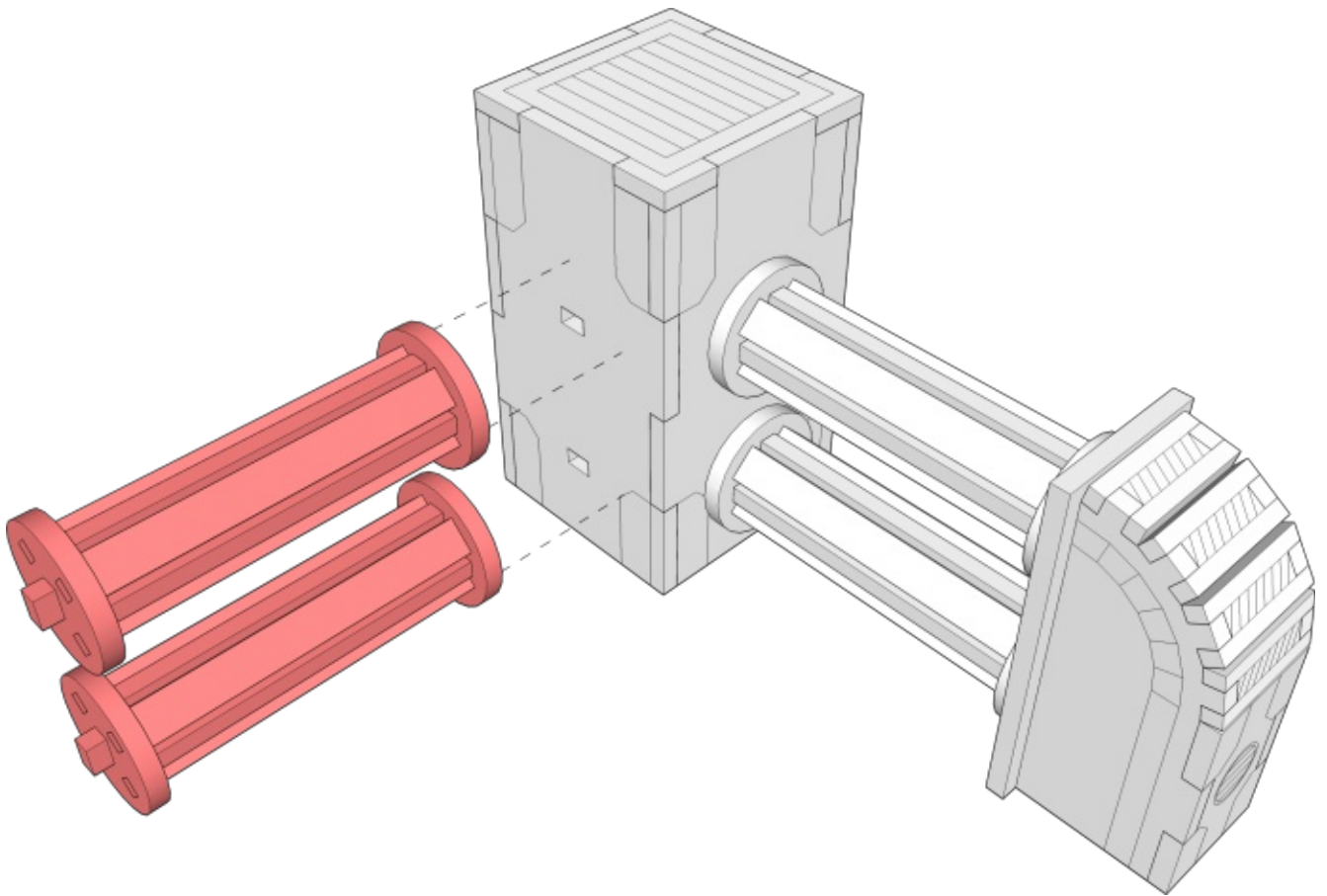



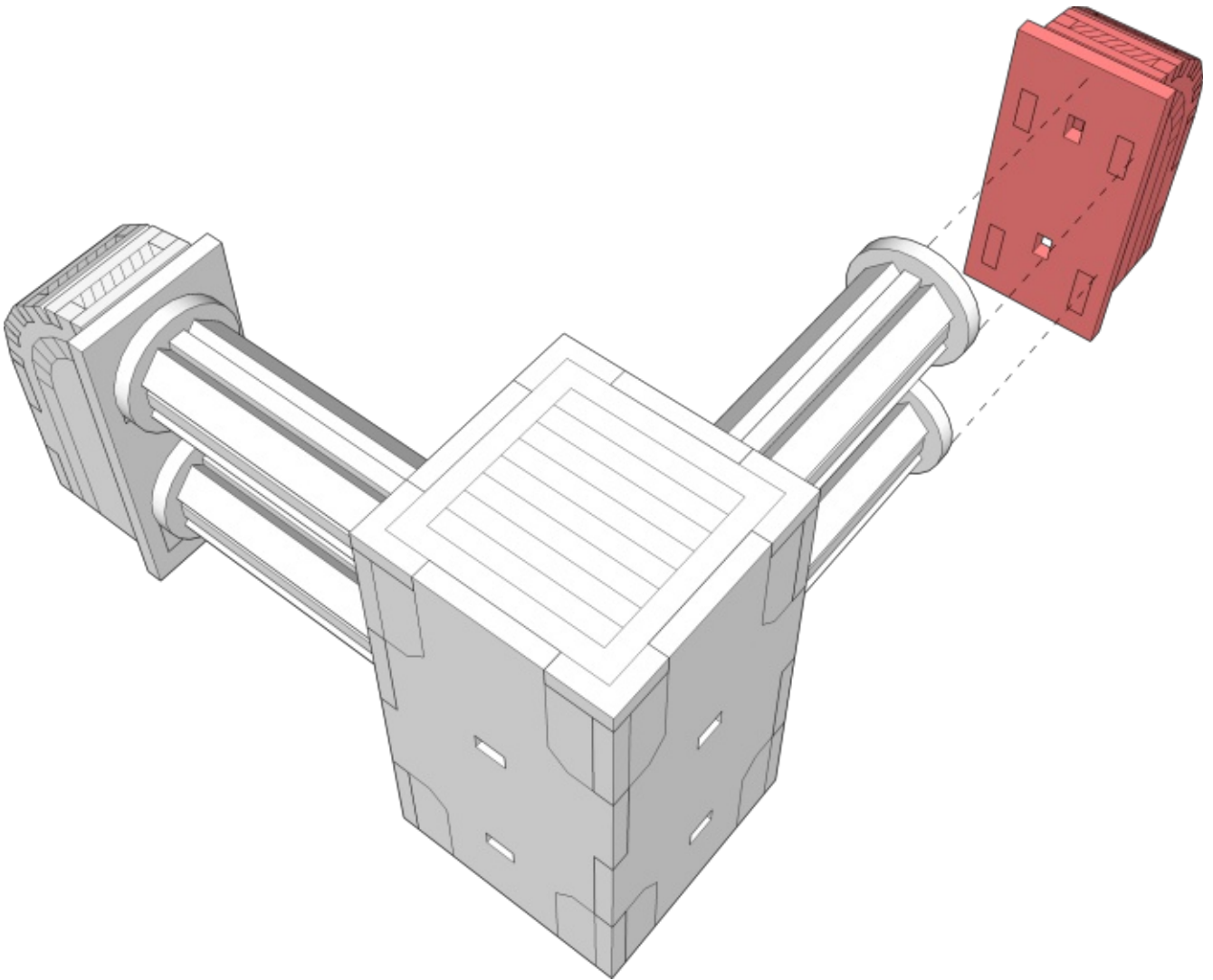



TABLETOP  
**SCENICS**

17

**TTSC-SFX-079**  
**Burton**  
**Quartersections**

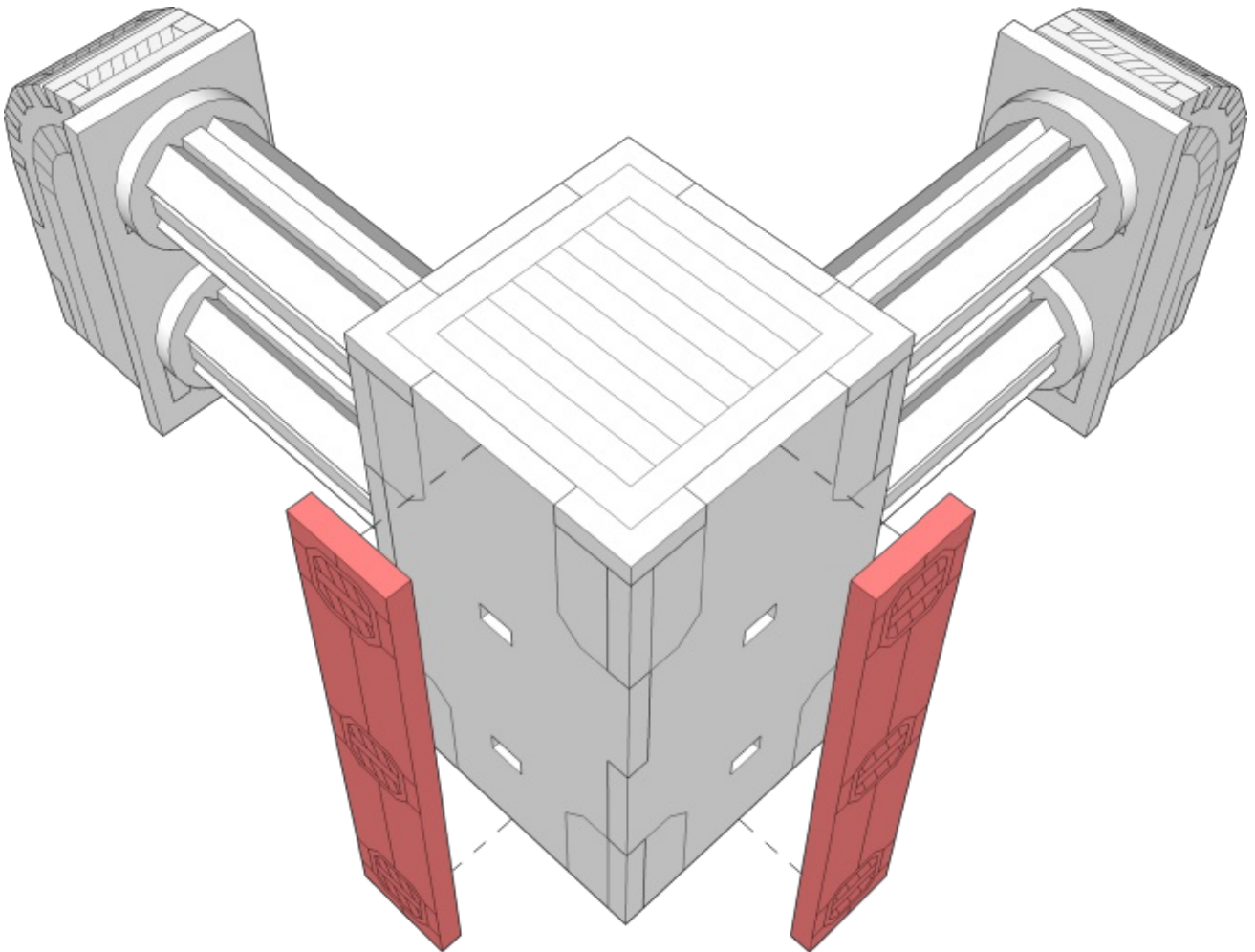



TABLETOP  
**SCENICS**

18

**TTSC-SFX-079**  
**Burton**  
**Quartersections**

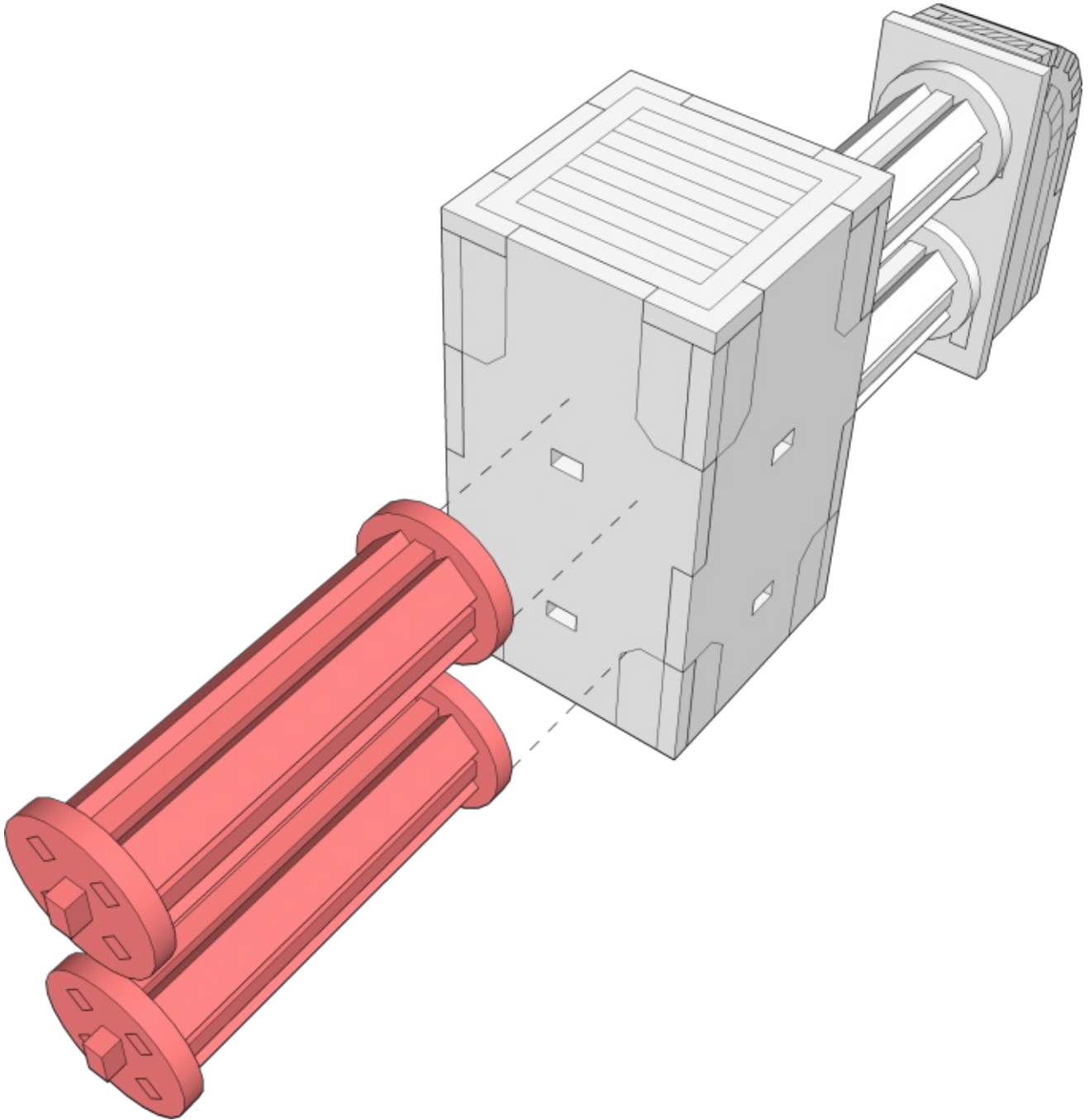

 **TTCOMBAT**

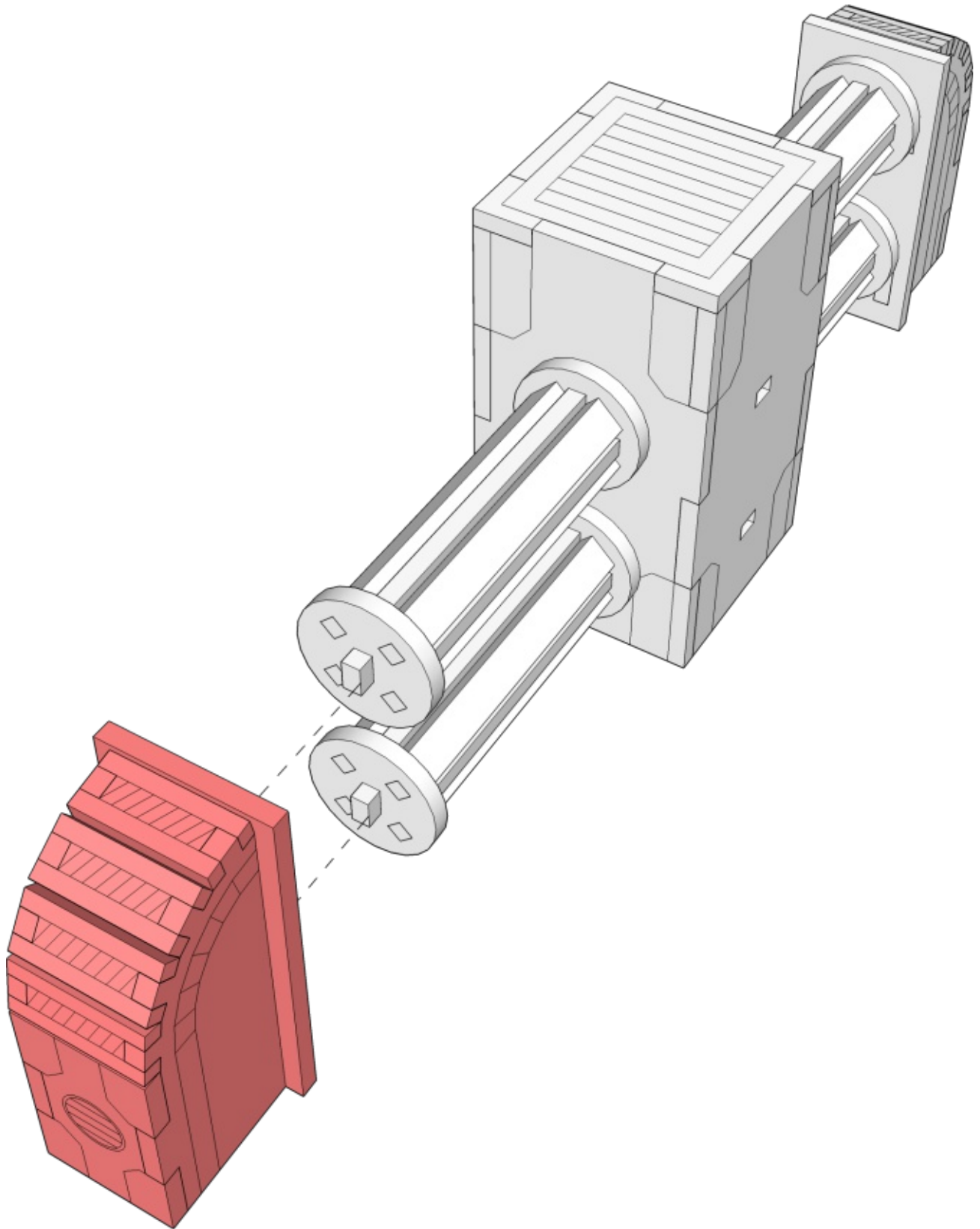



TABLETOP  
**SCENICS**

20

**TTSC-SFX-079**  
**Burton**  
**Quartersections**

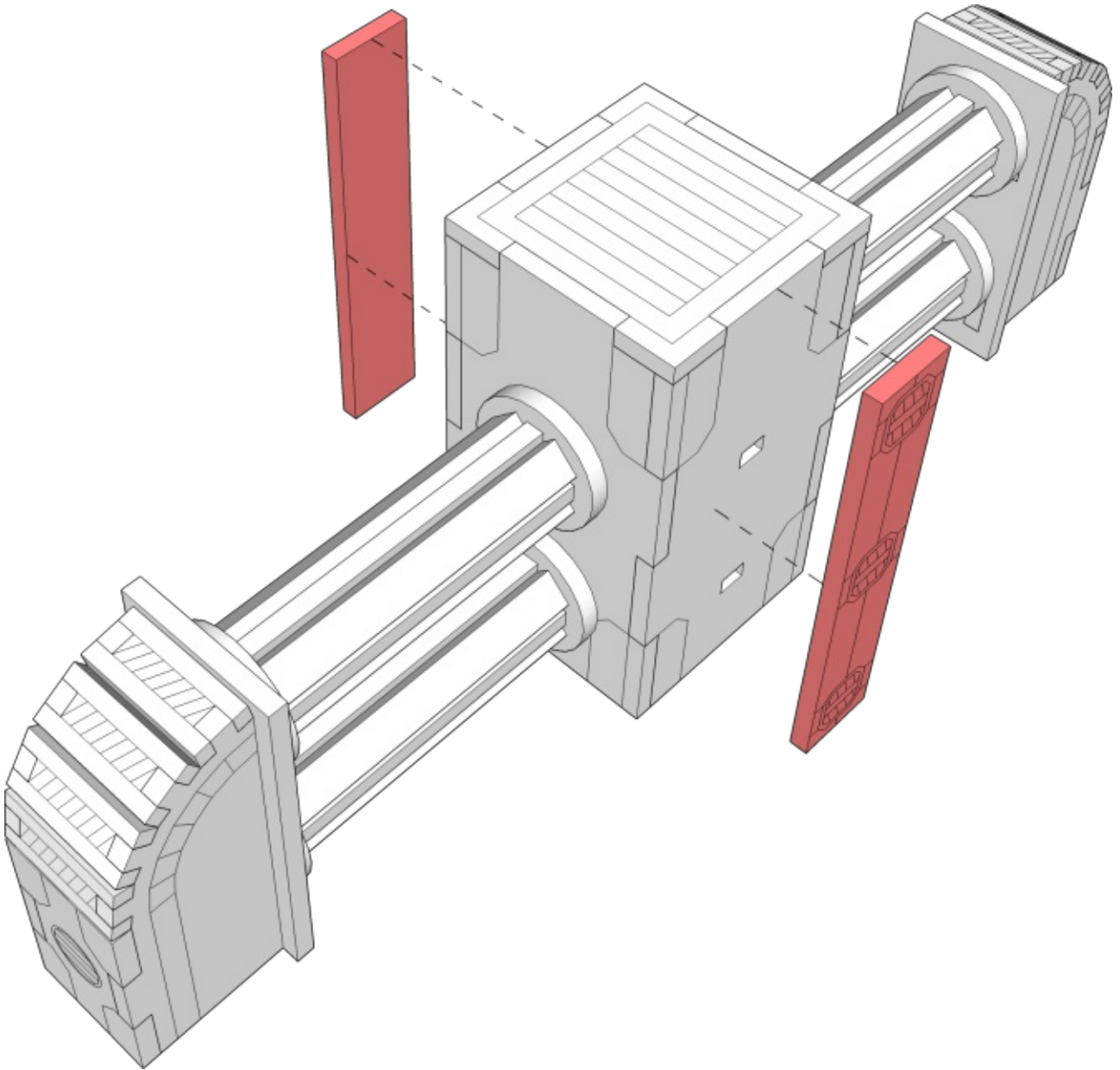

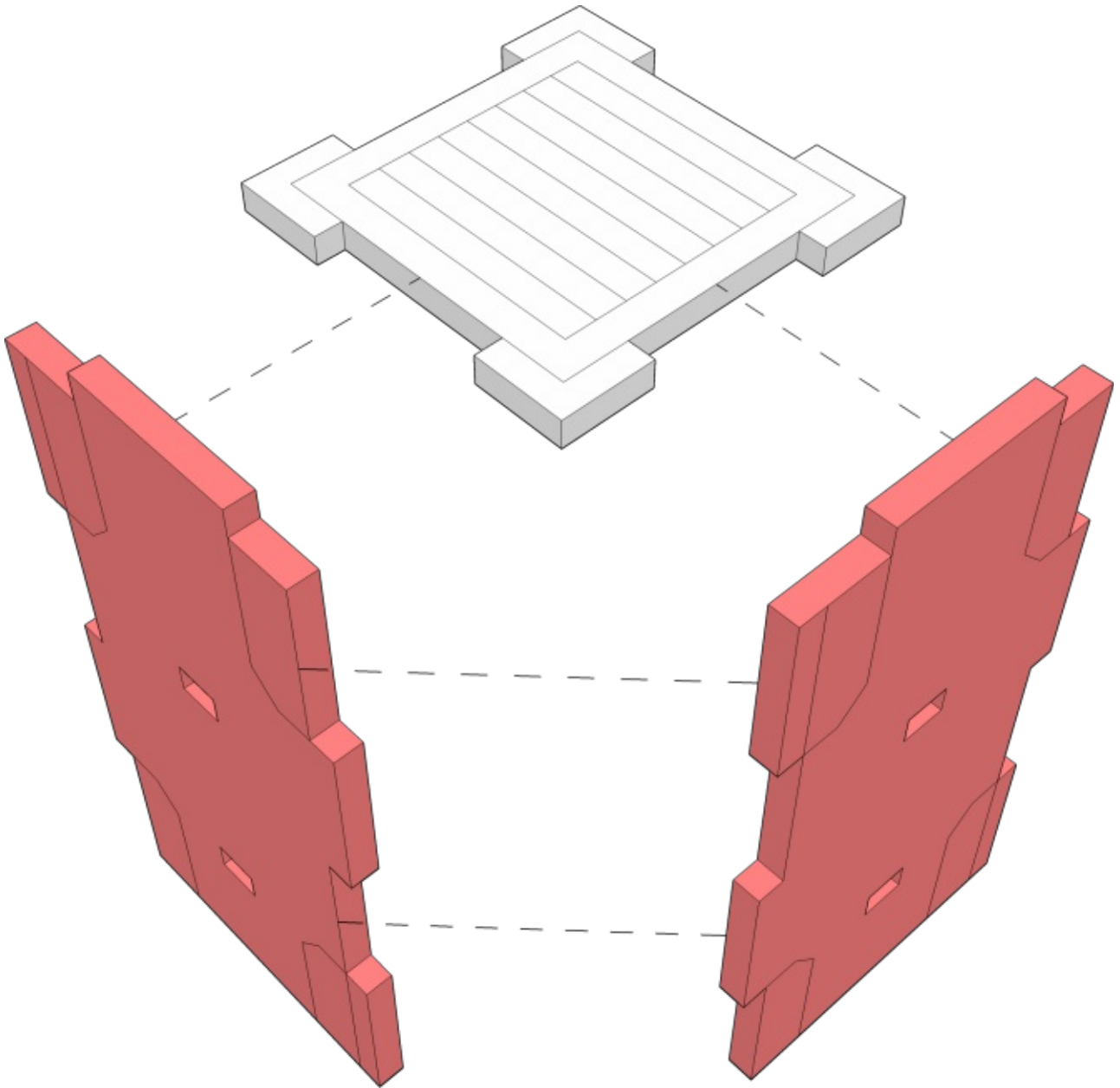

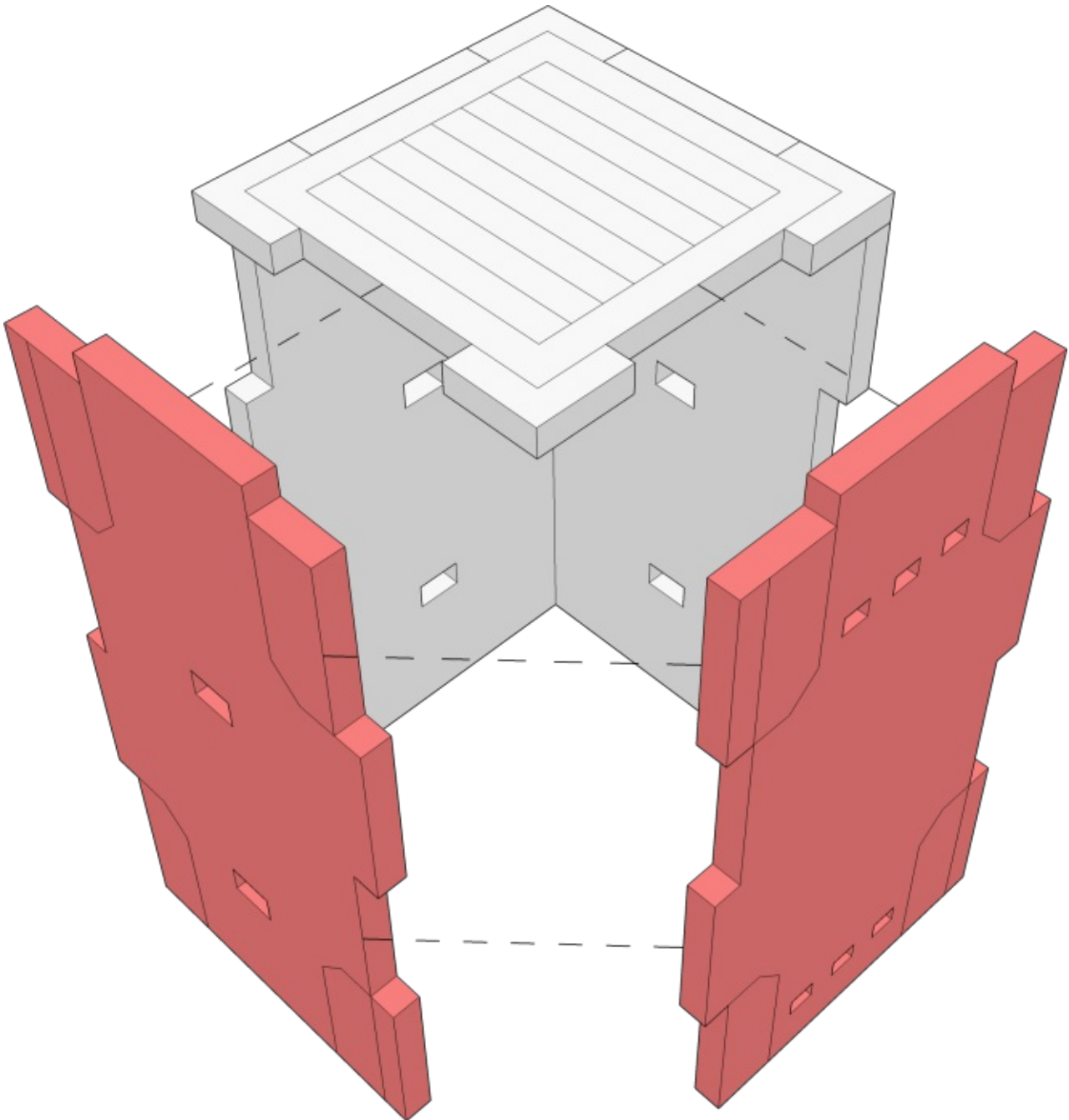

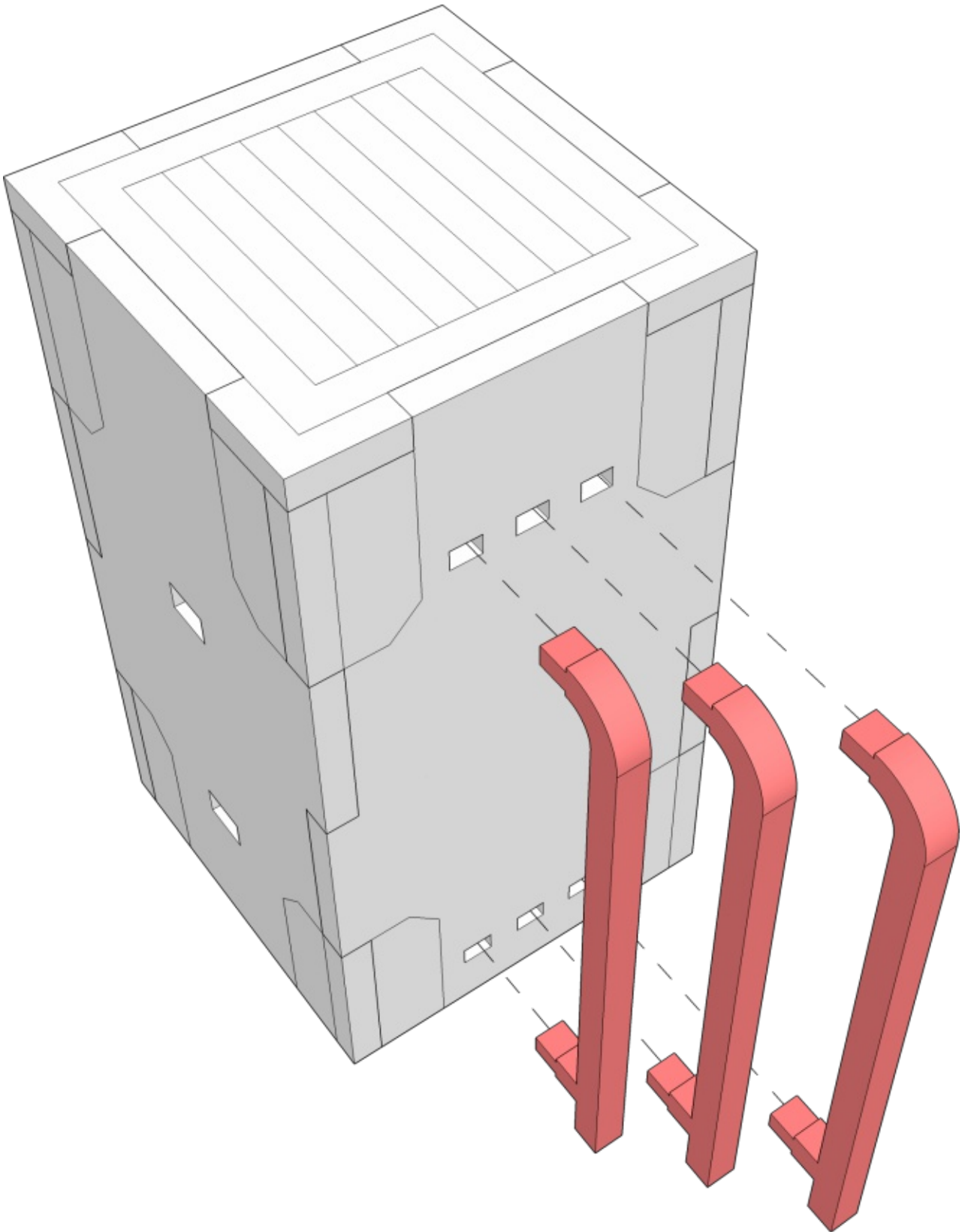





TABLETOP  
**SCENICS**

24

**TTSC-SFX-079**  
**Burton**  
**Quartersections**

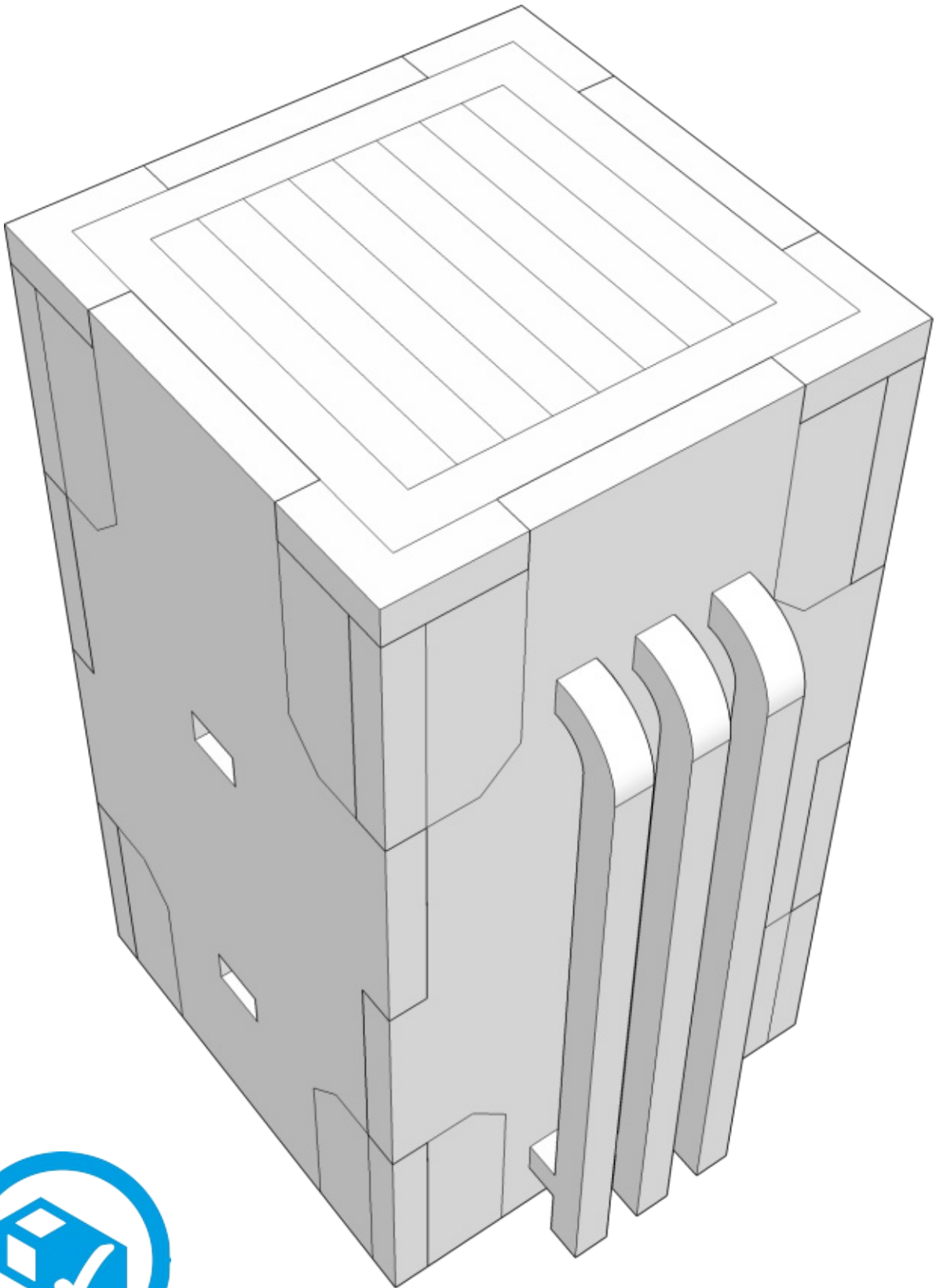

 **TTCOMBAT**

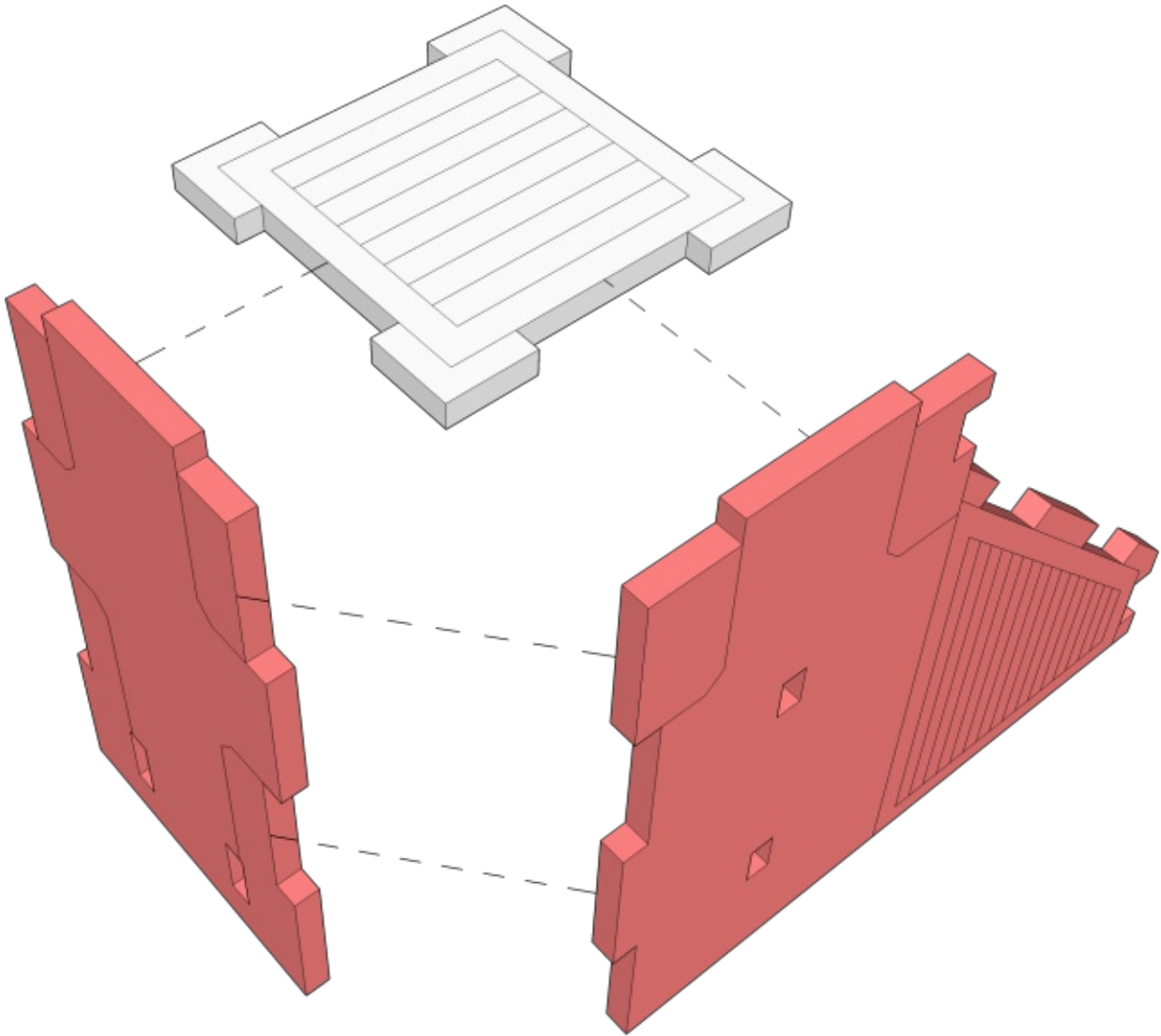

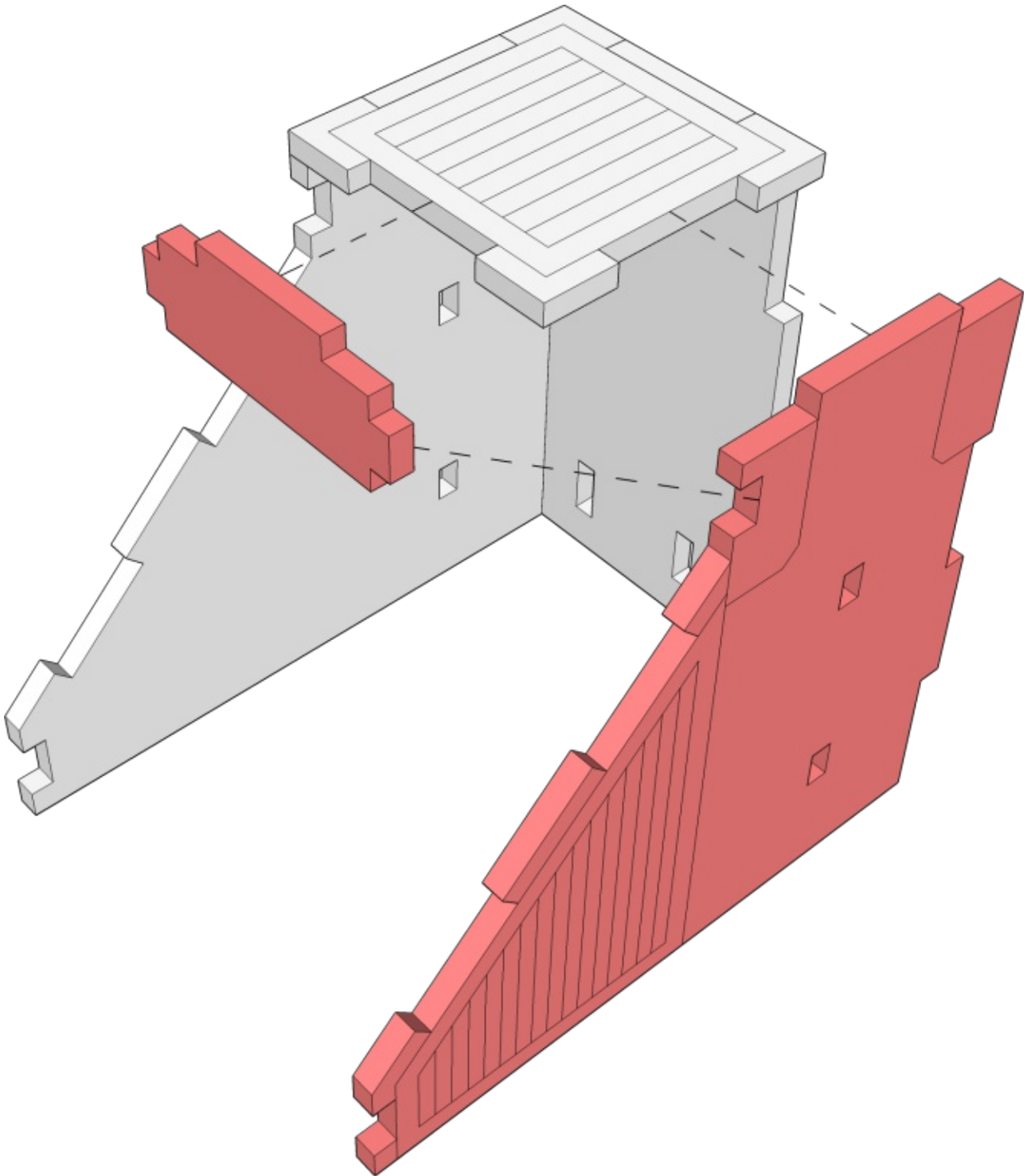

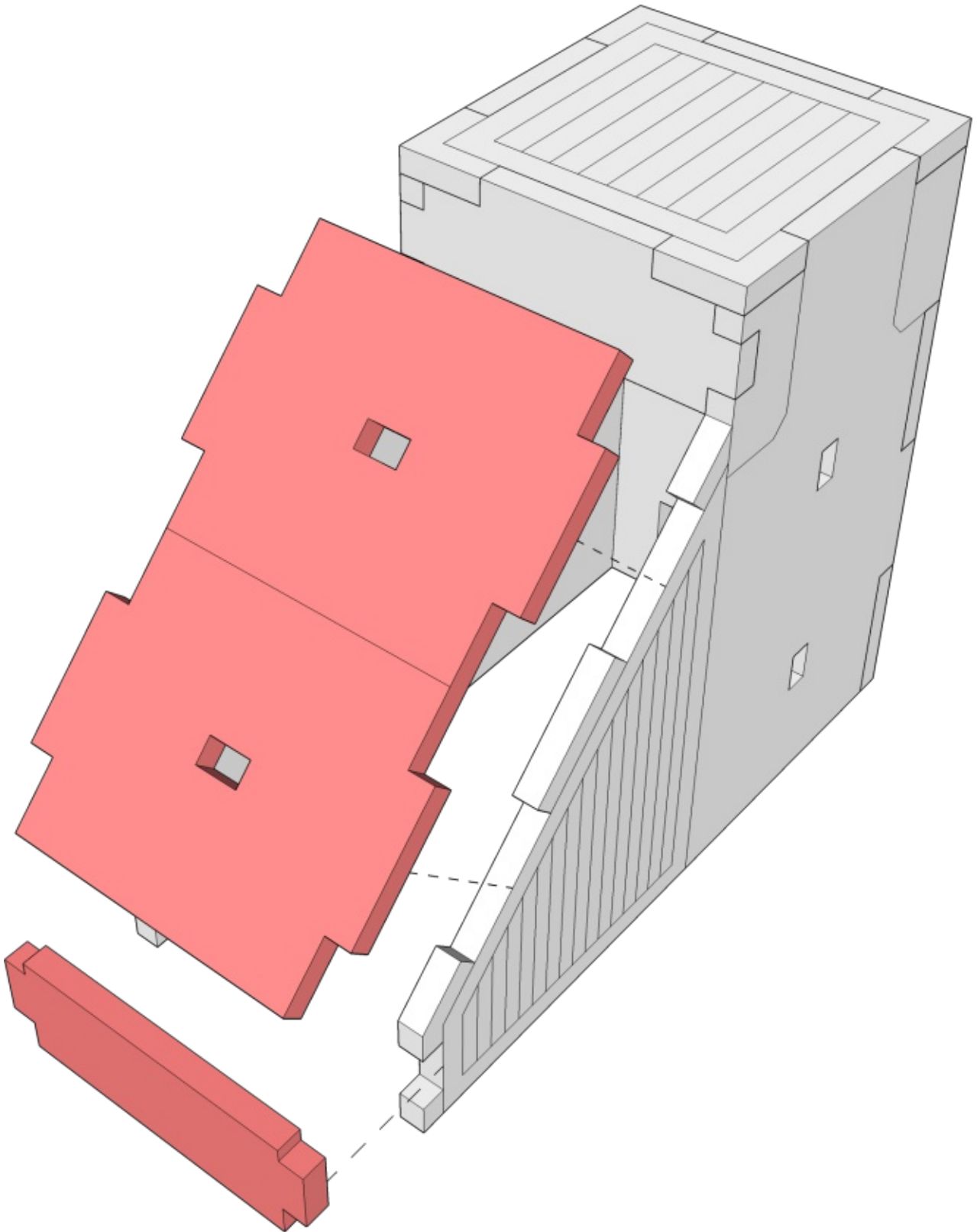

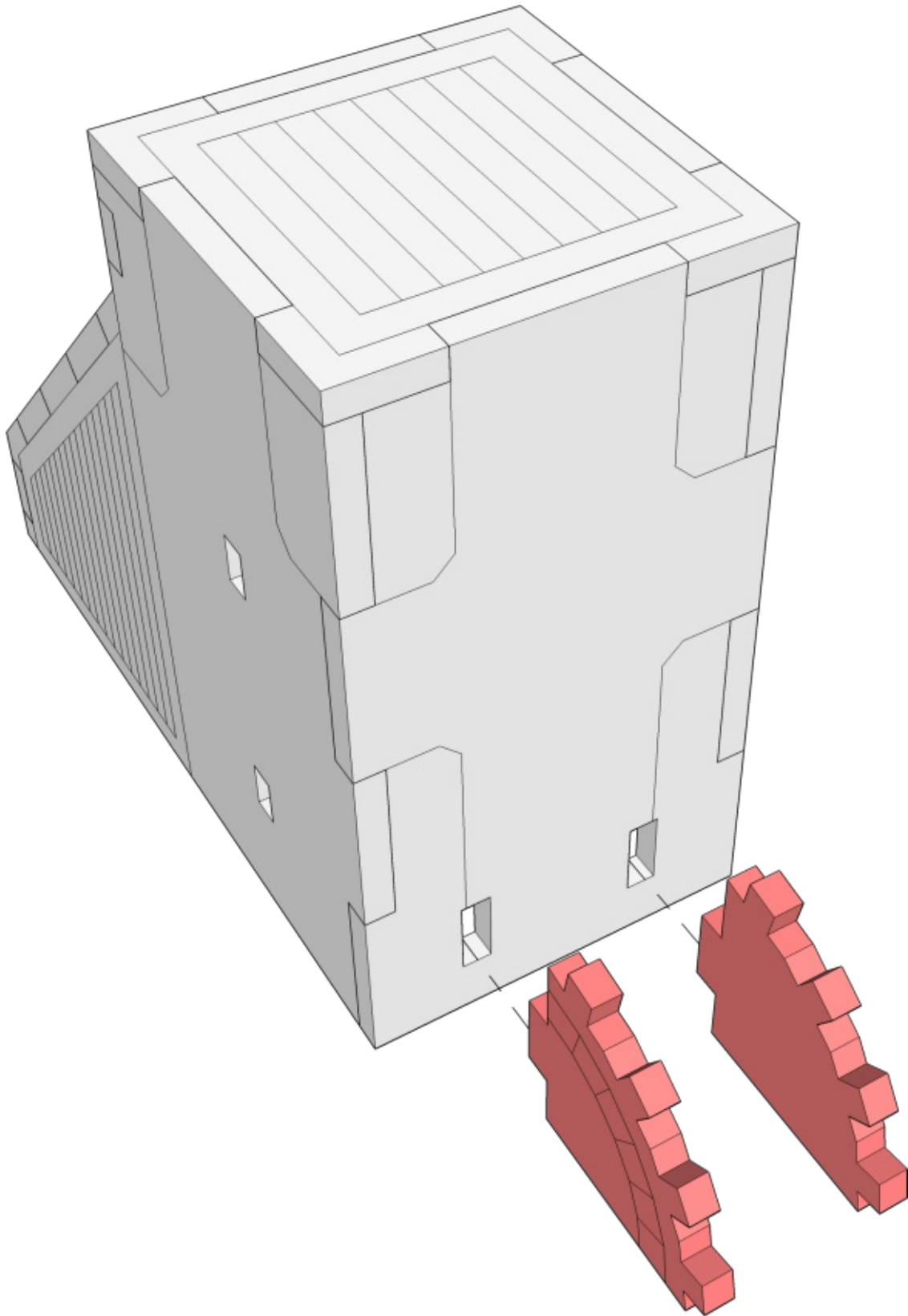



TABLETOP  
**SCENICS**

29

**TTSC-SFX-079**  
**Burton**  
**Quartersections**

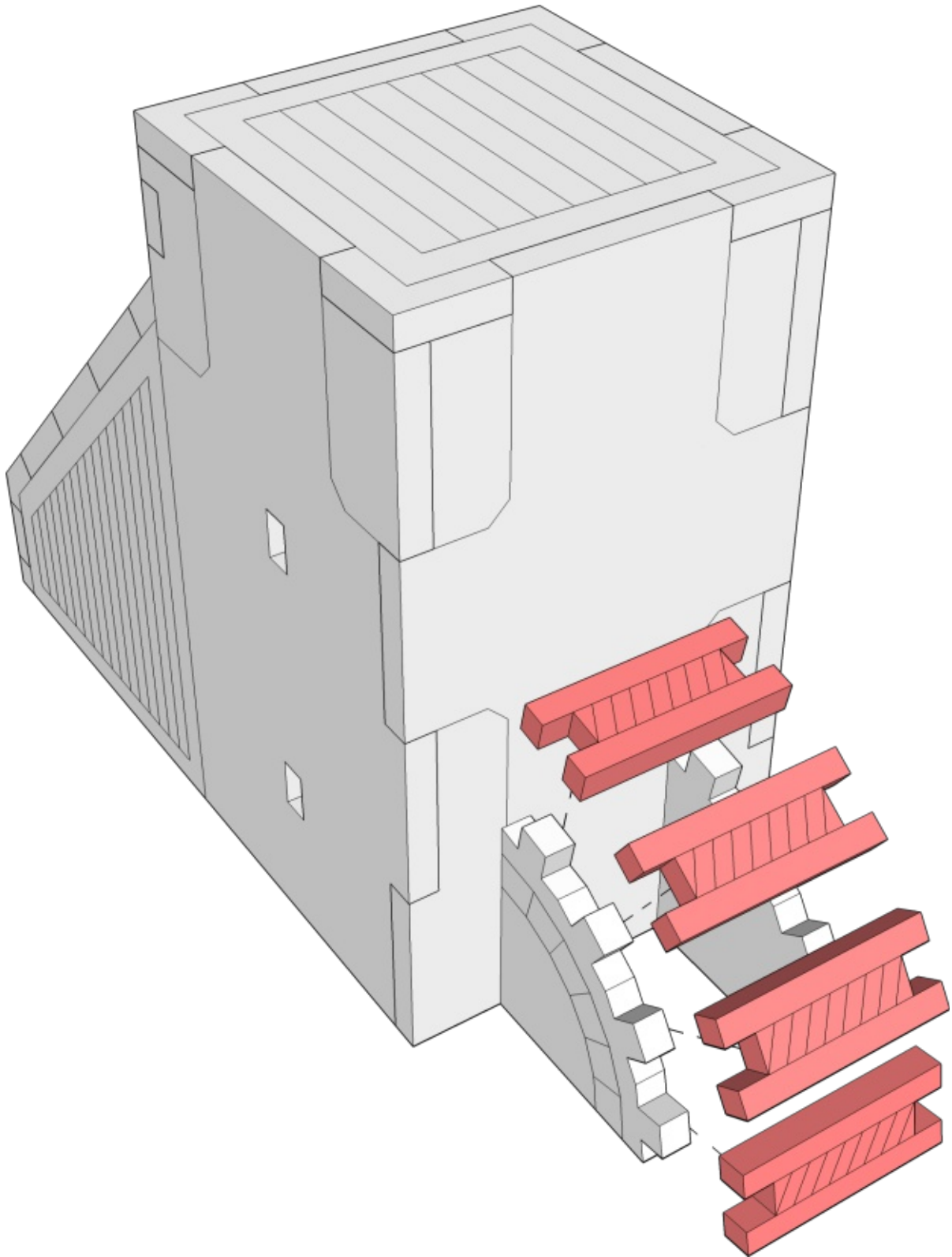



TABLETOP  
**SCENICS**

30

**TTSC-SFX-079**  
**Burton**  
**Quartersections**

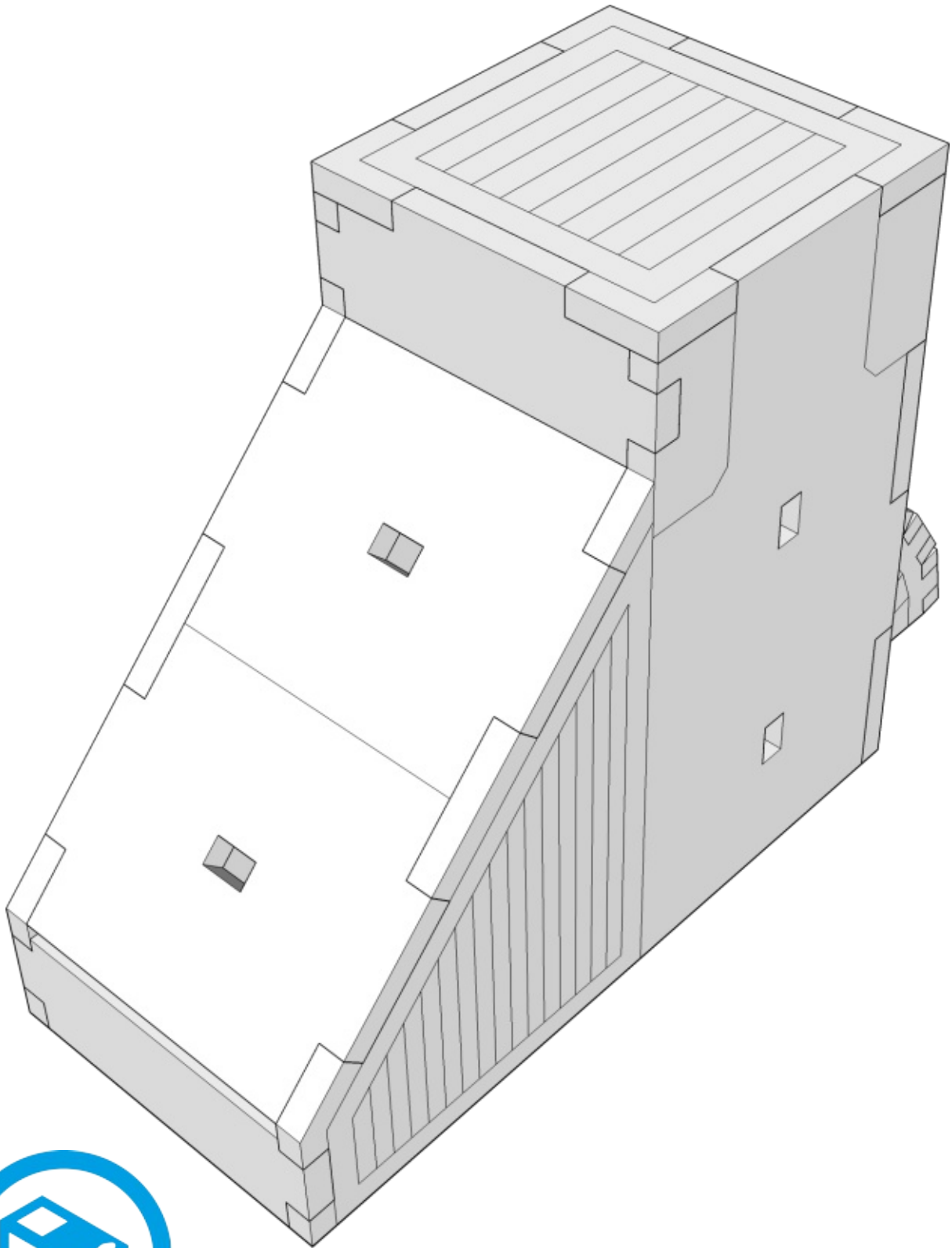

 **TTCOMBAT**

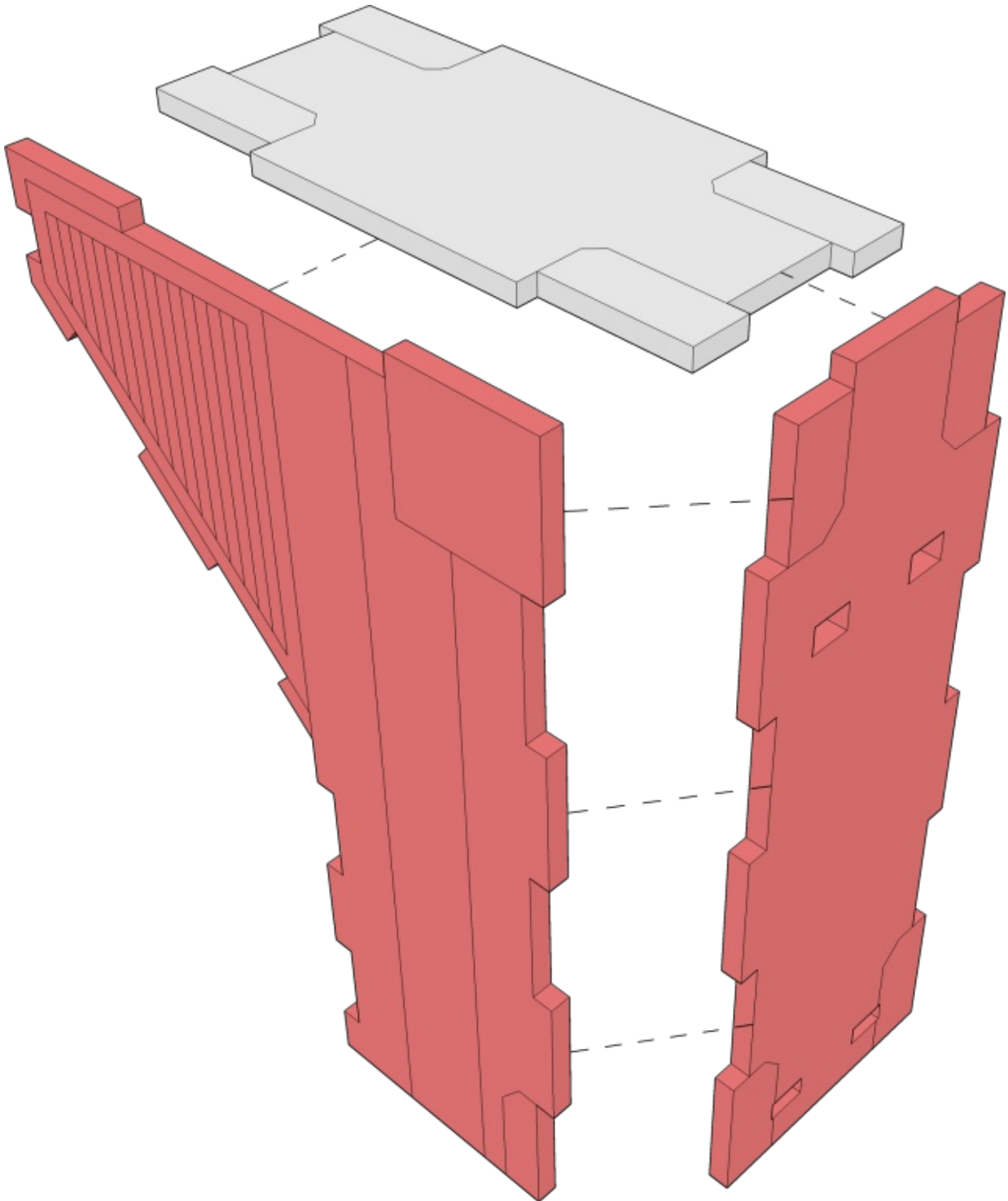



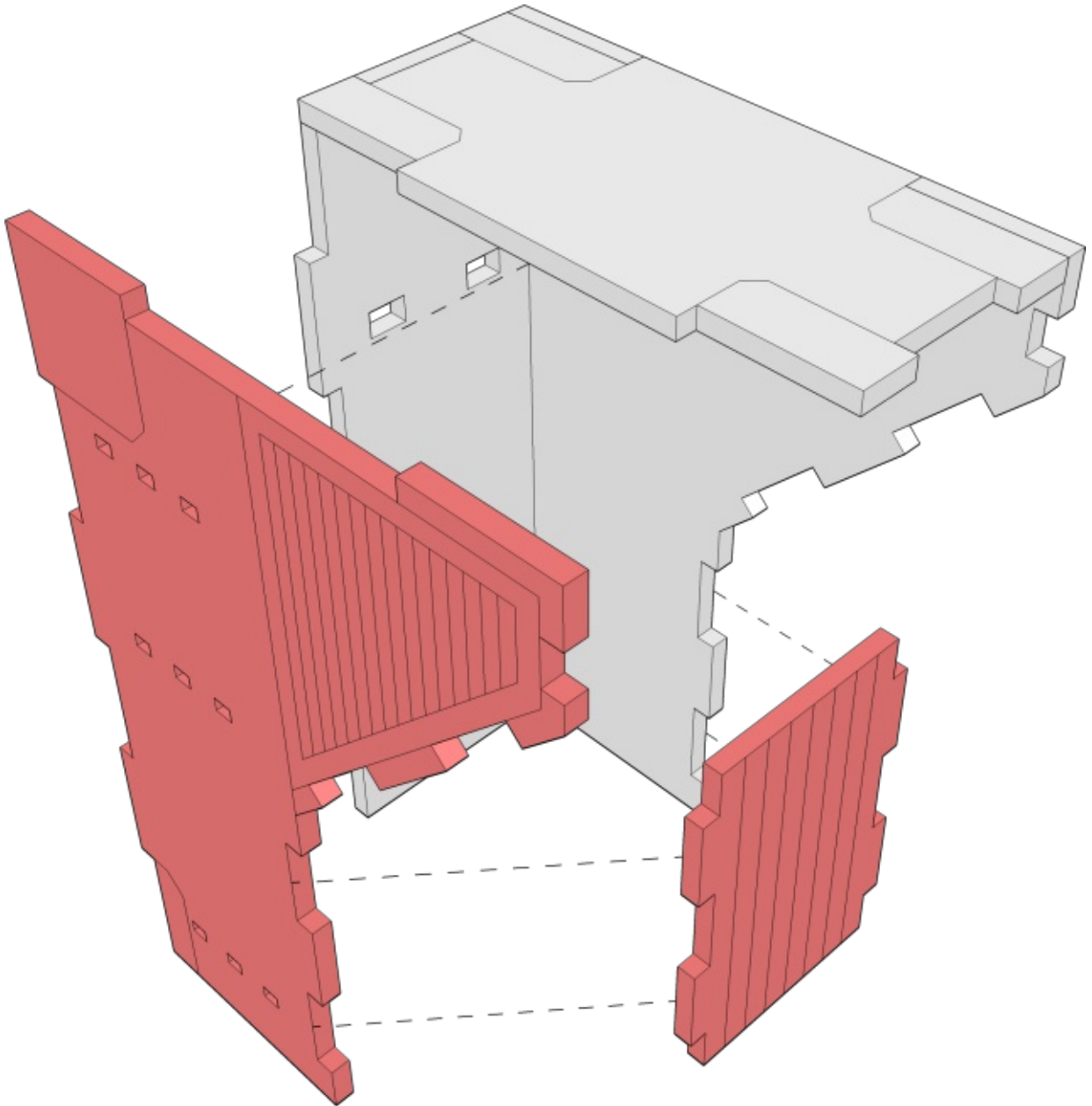

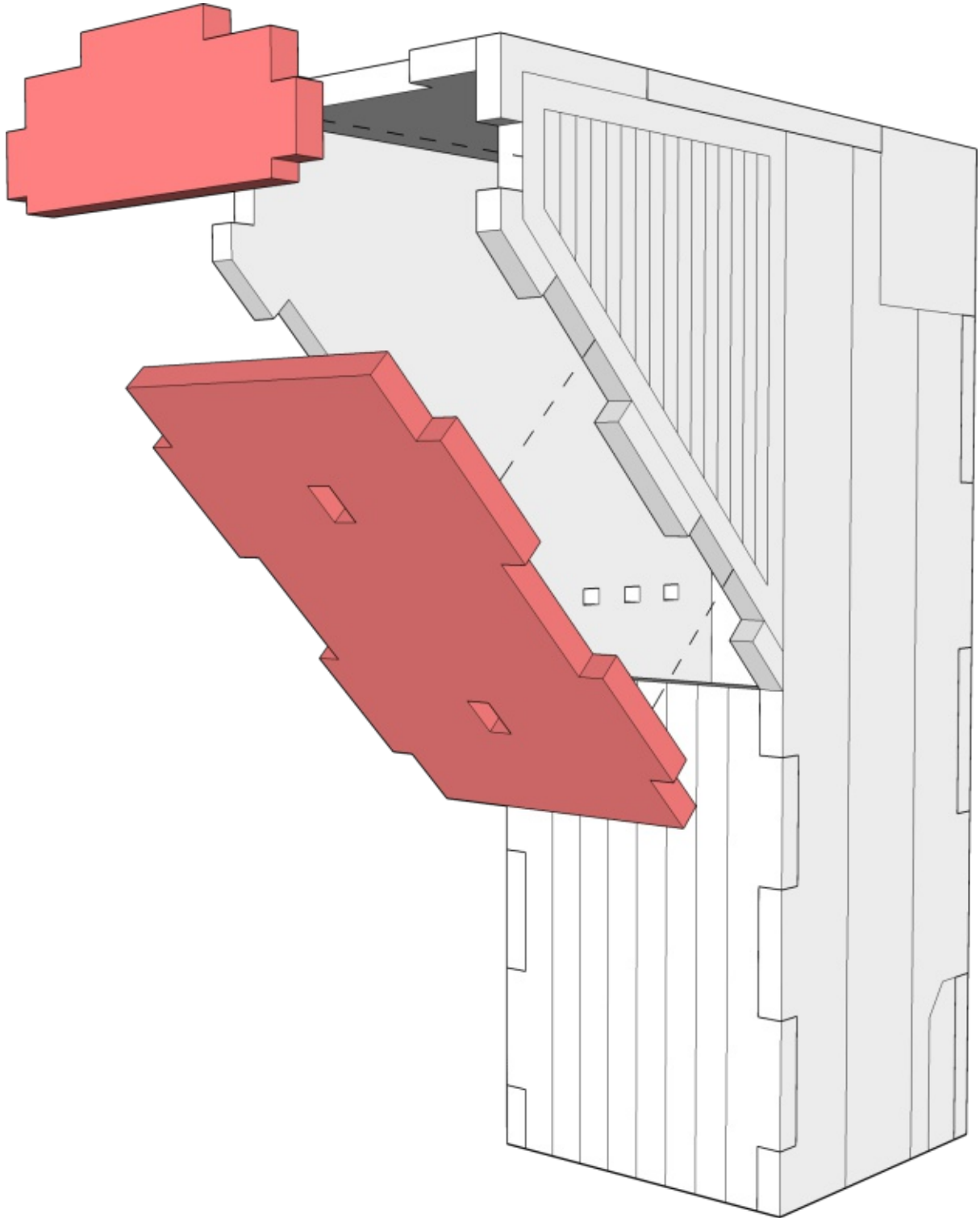



TABLETOP  
**SCENICS**

34

**TTSC-SFX-079**  
**Burton**  
**Quartersections**

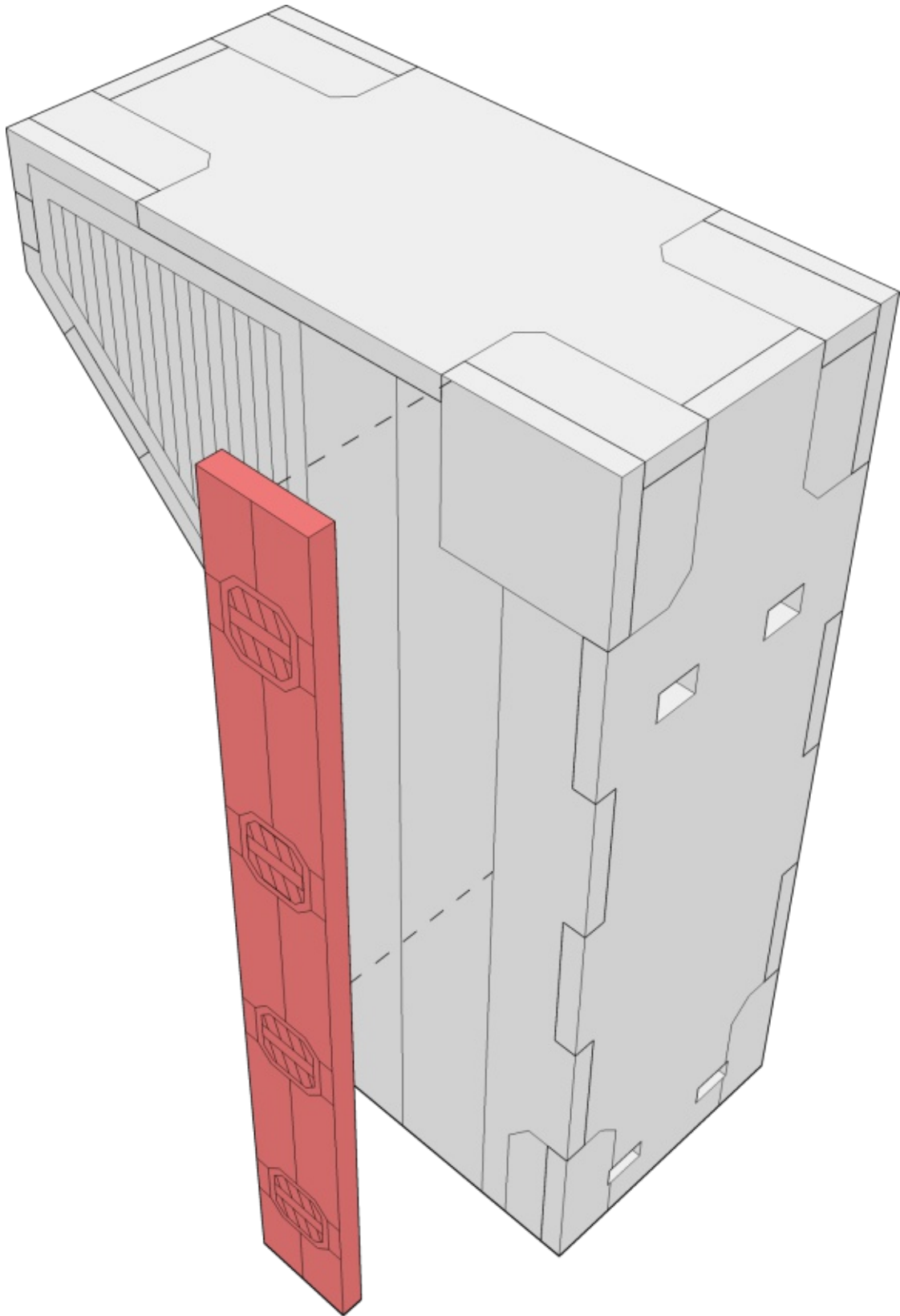



TABLETOP  
**SCENICS**

35

**TTSC-SFX-079**  
**Burton**  
**Quartersections**

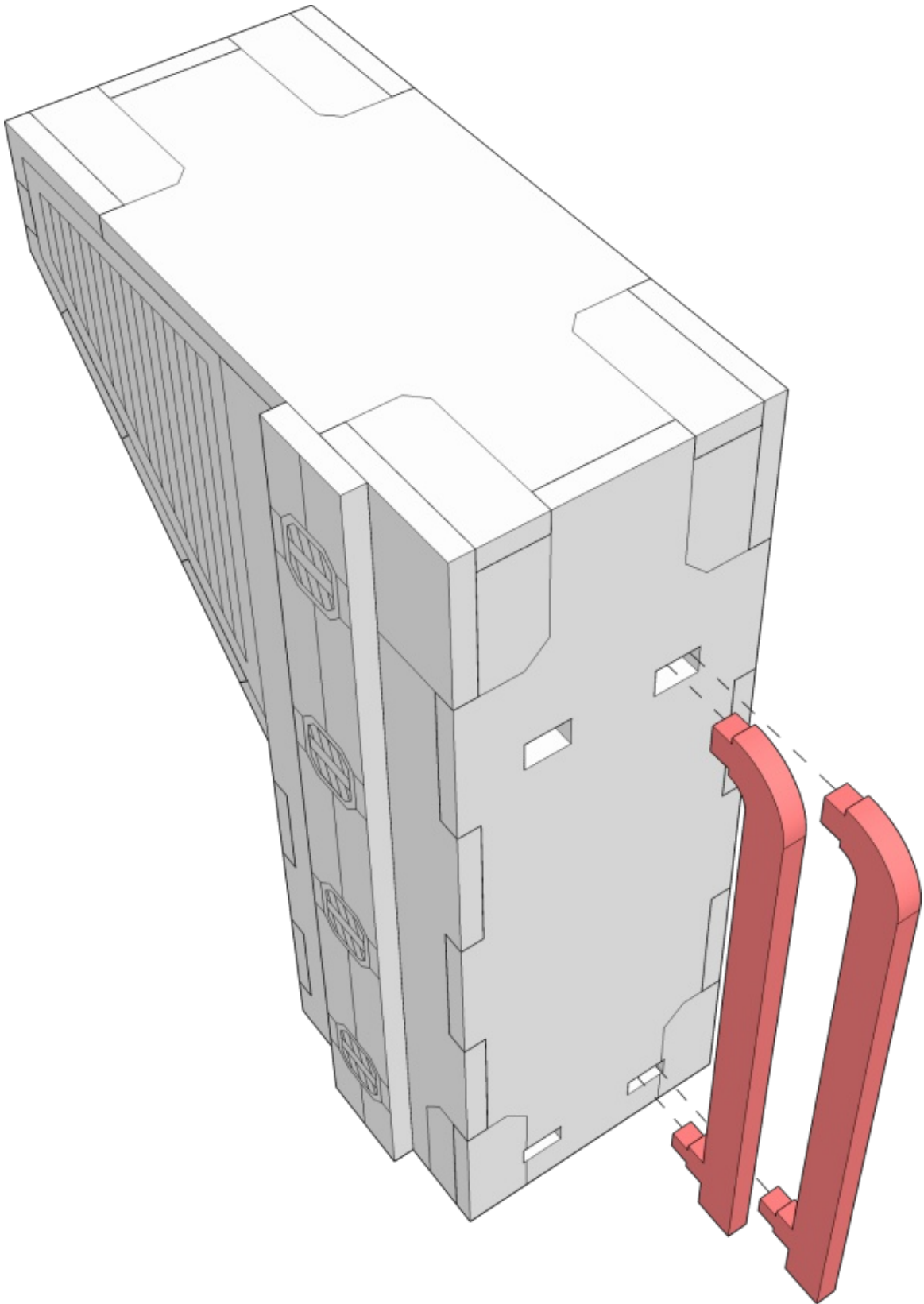

 **TTCOMBAT**



TABLETOP  
**SCENICS**

36

**TTSC-SFX-079**  
**Burton**  
**Quartersections**

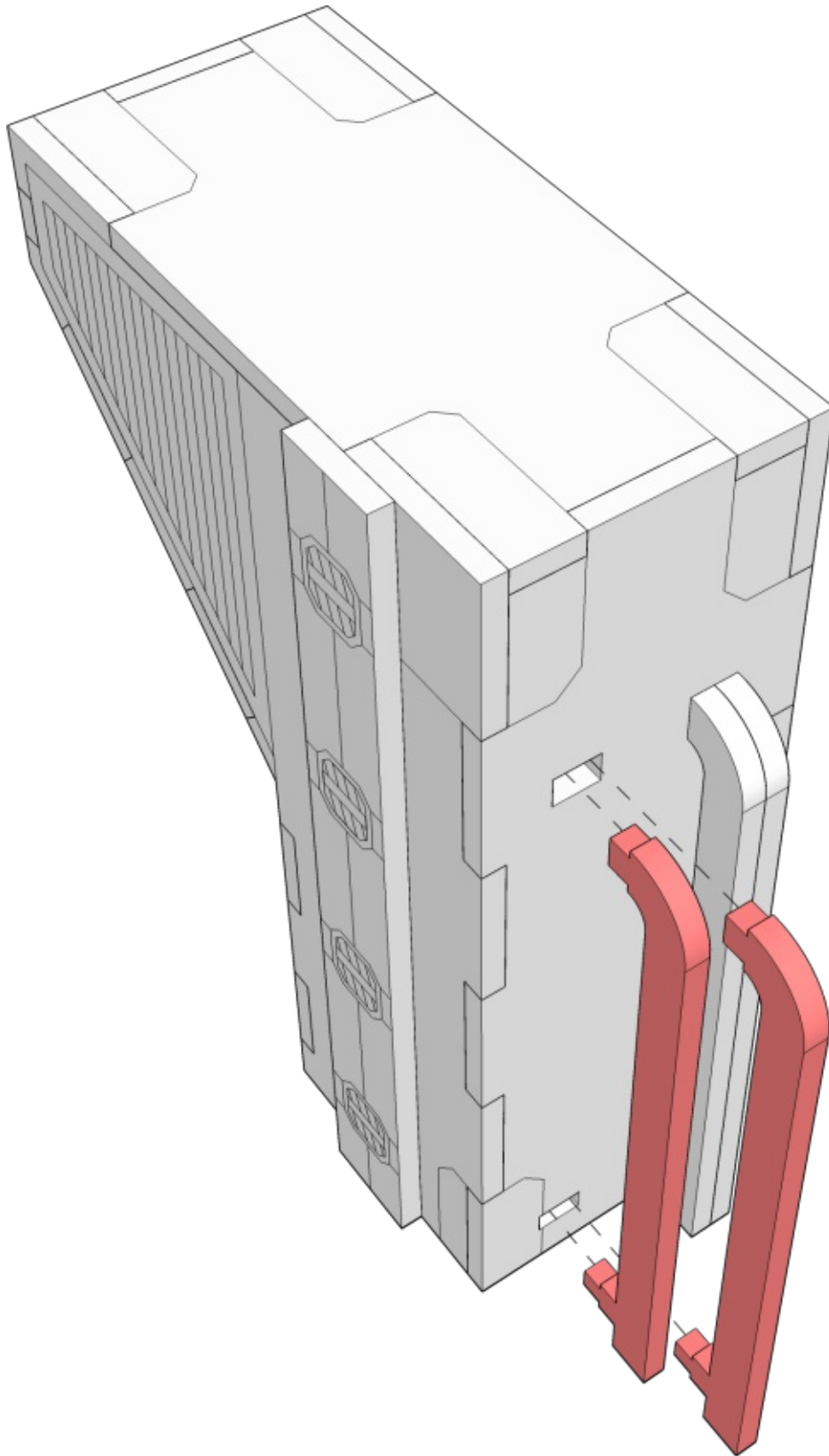

 **TTCOMBAT**

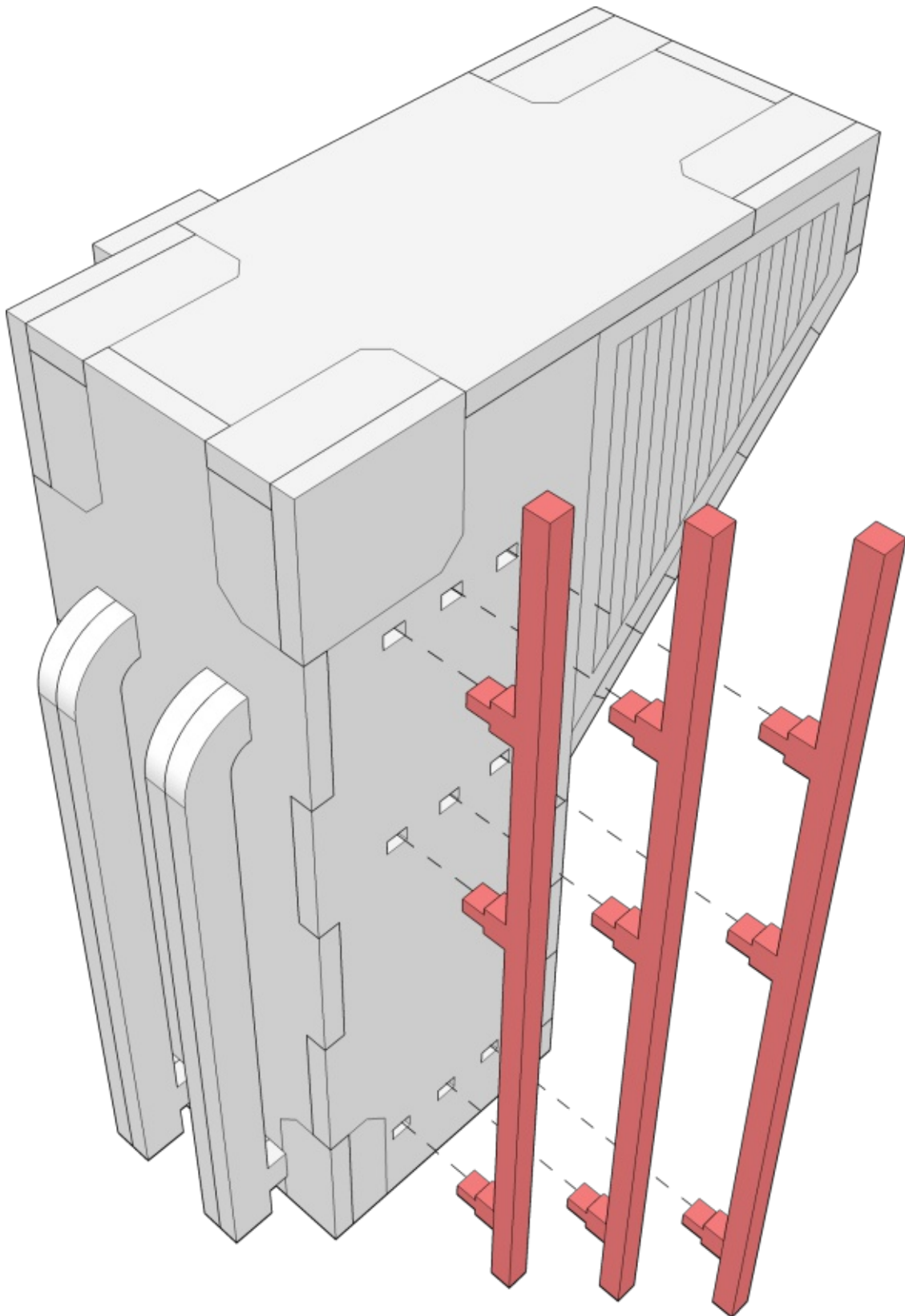



TABLETOP  
**SCENICS**

38

**TTSC-SFX-079**  
**Burton**  
**Quartersections**

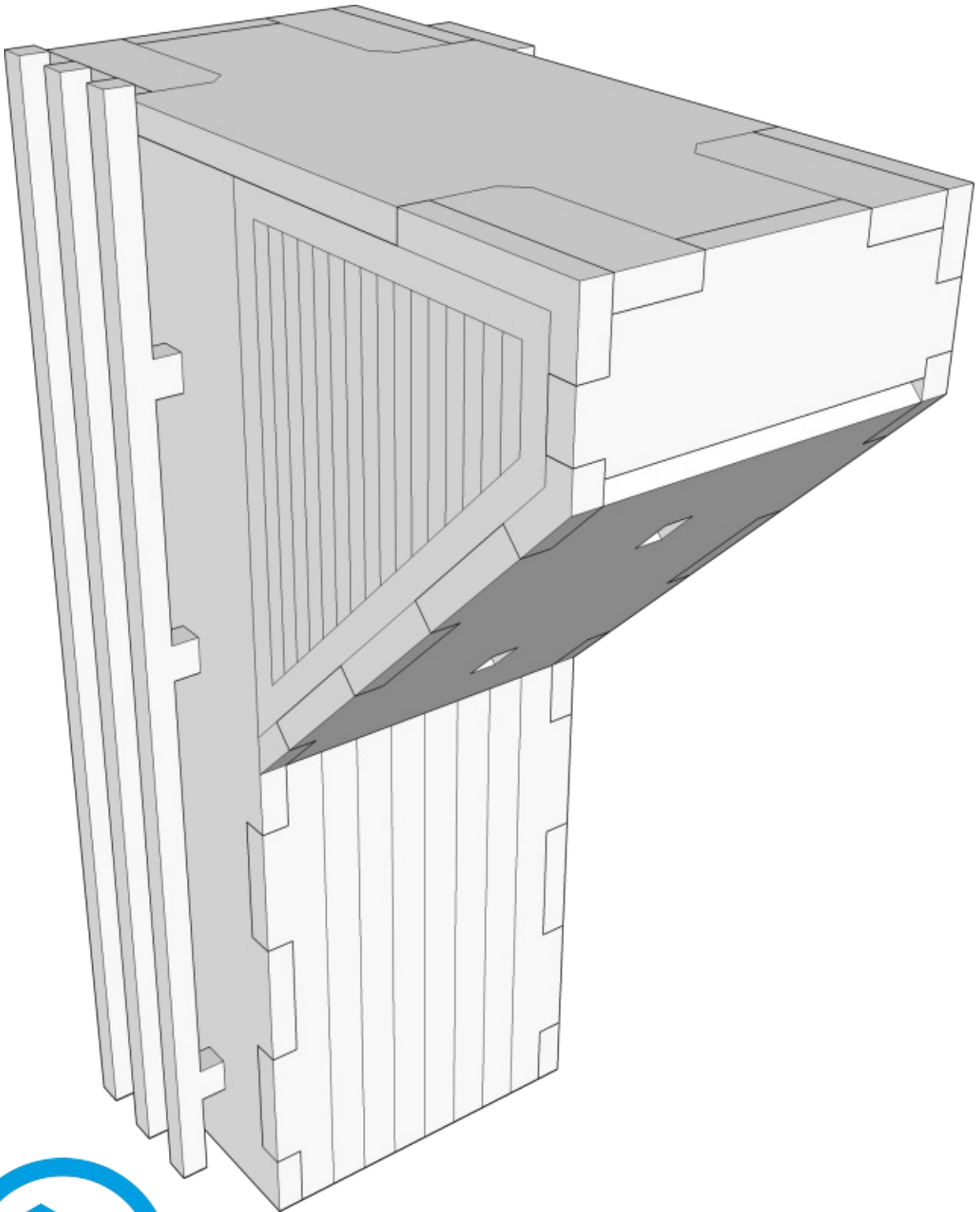

 **TTCOMBAT**

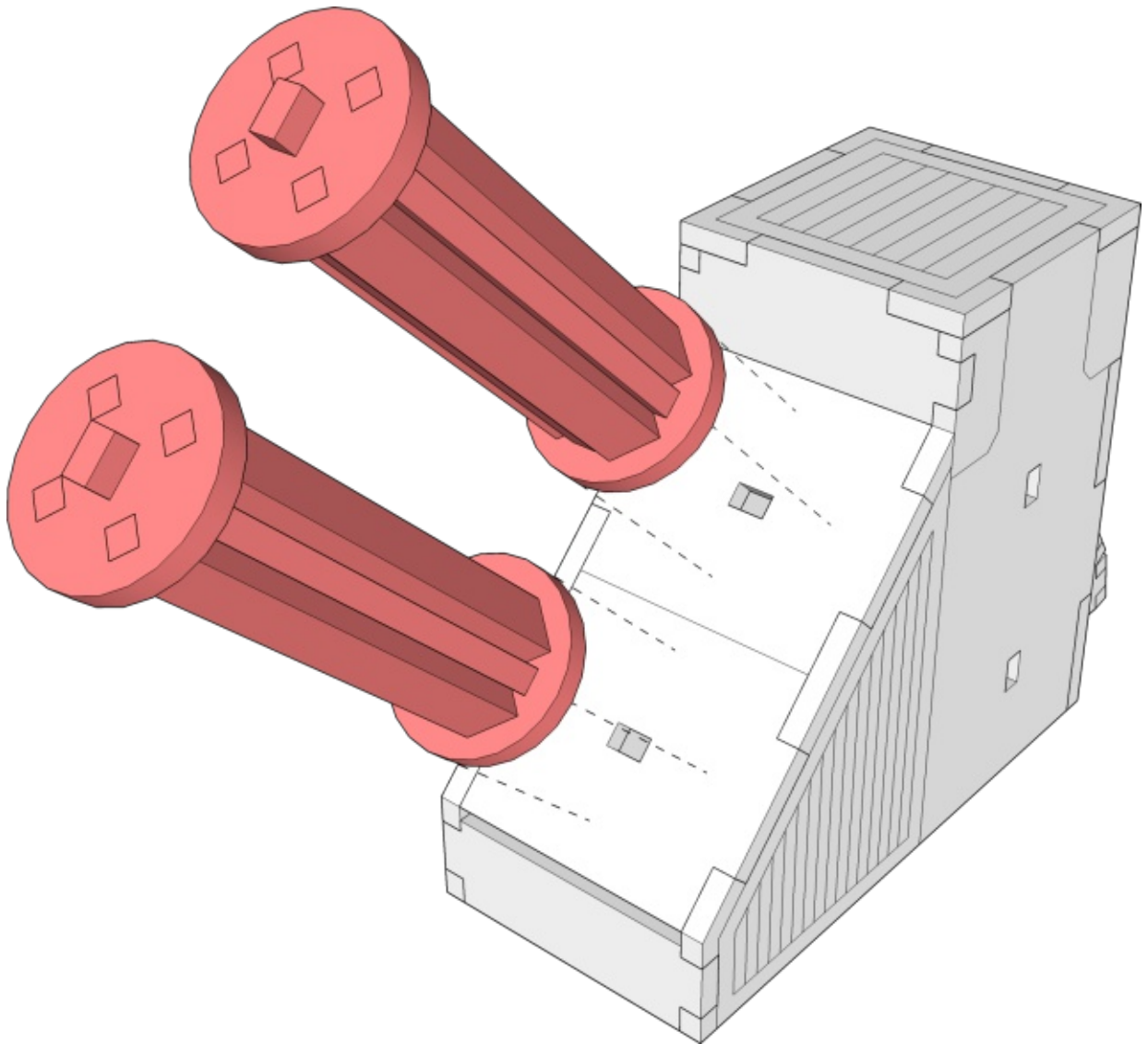





TABLETOP  
**SCENICS**

40

**TTSC-SFX-079**  
**Burton**  
**Quartersections**

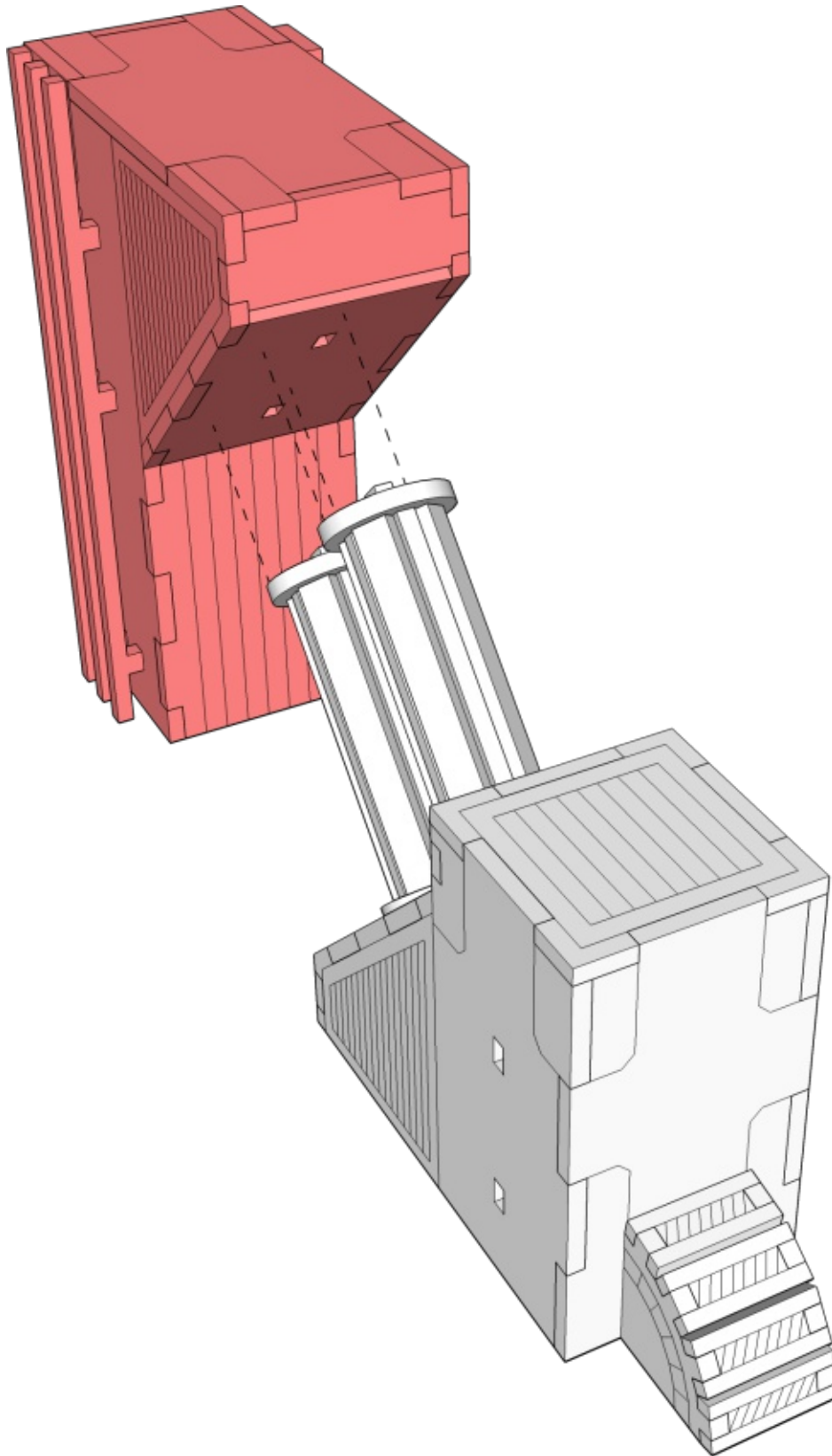



**TABLETOP  
SCENICS**

**41**

**TTSC-SFX-079  
Burton  
Quartersections**

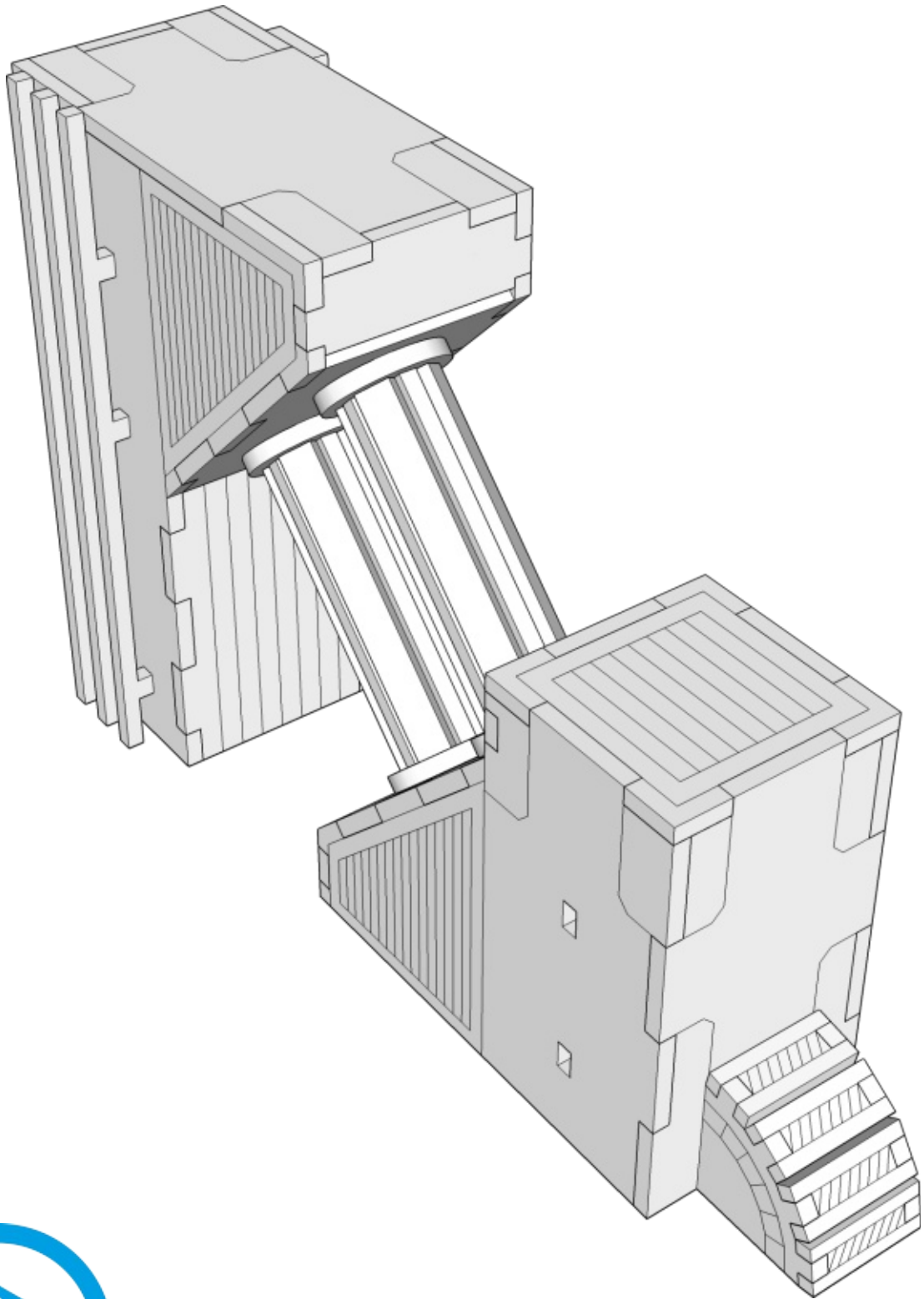

 **TTCOMBAT**

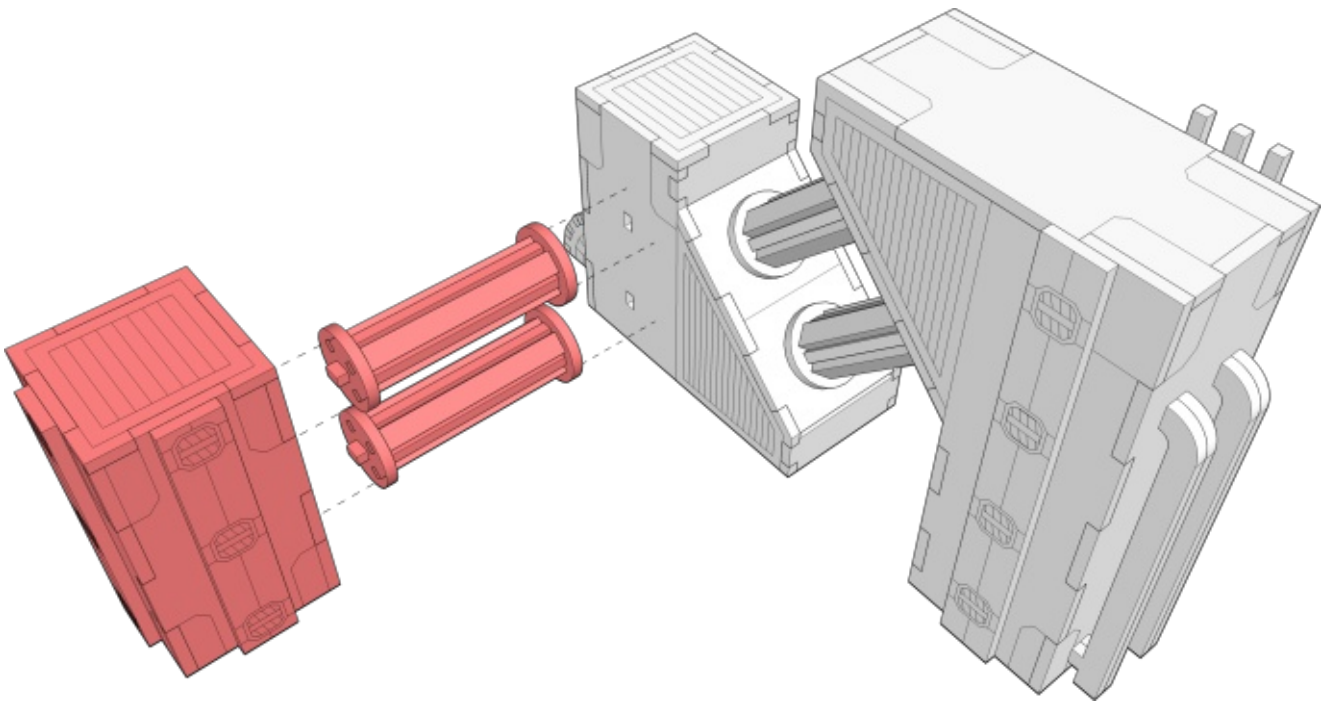



TABLETOP  
**SCENICS**

43

**TTSC-SFX-079**  
**Burton**  
**Quartersections**

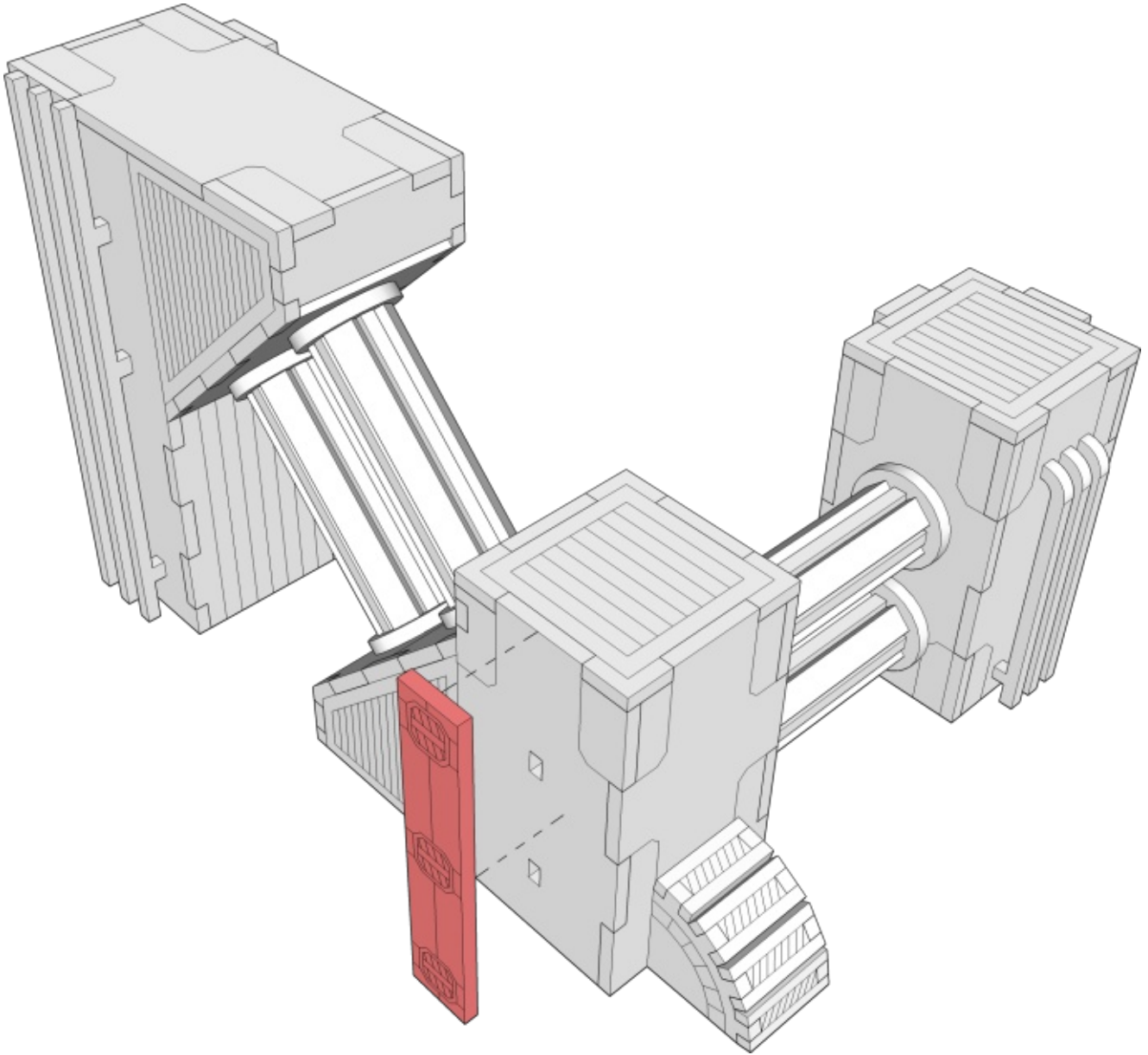



TABLETOP  
**SCENICS**

44

**TTSC-SFX-079**  
**Burton**  
**Quartersections**

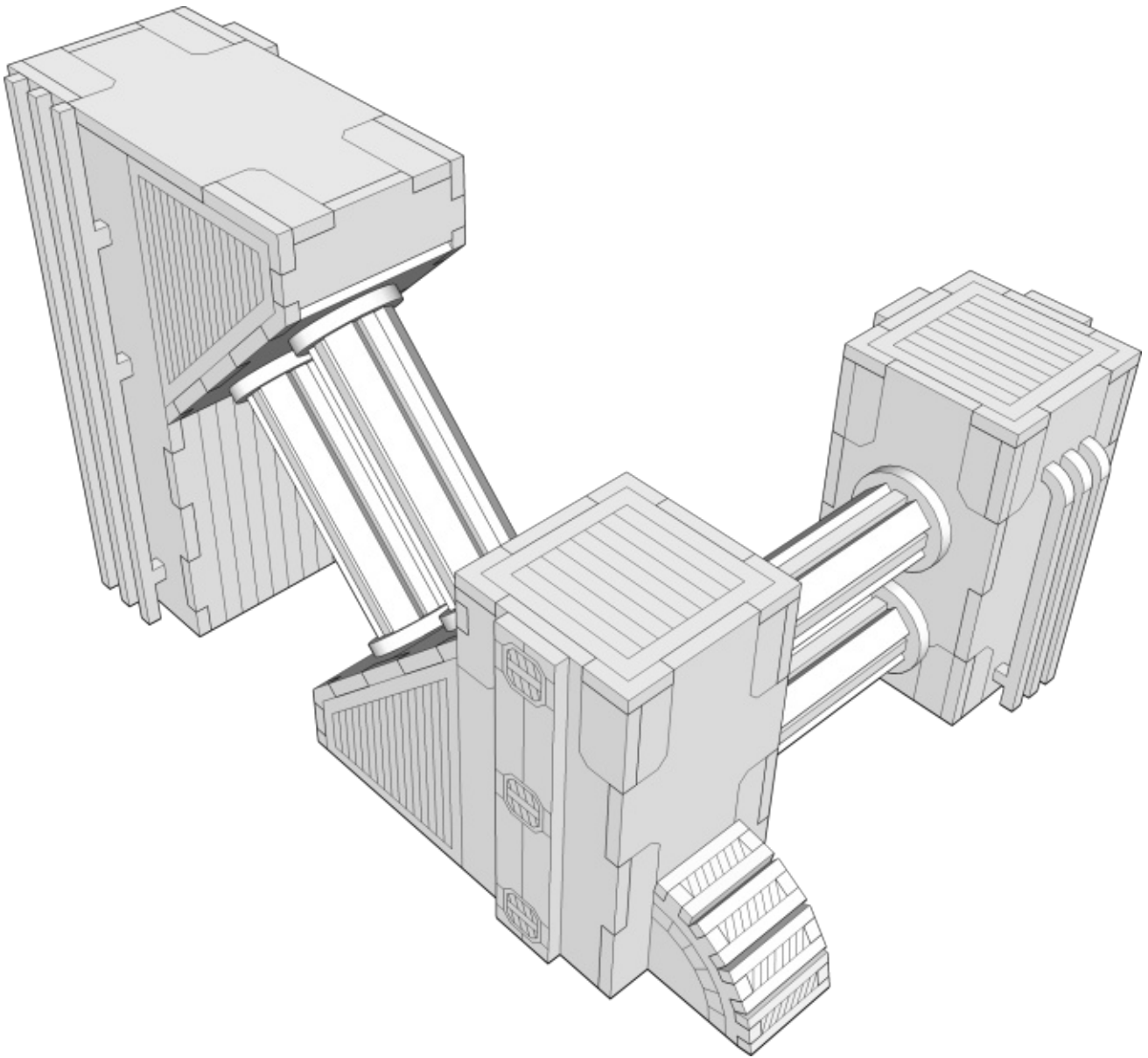

 **TTCOMBAT**

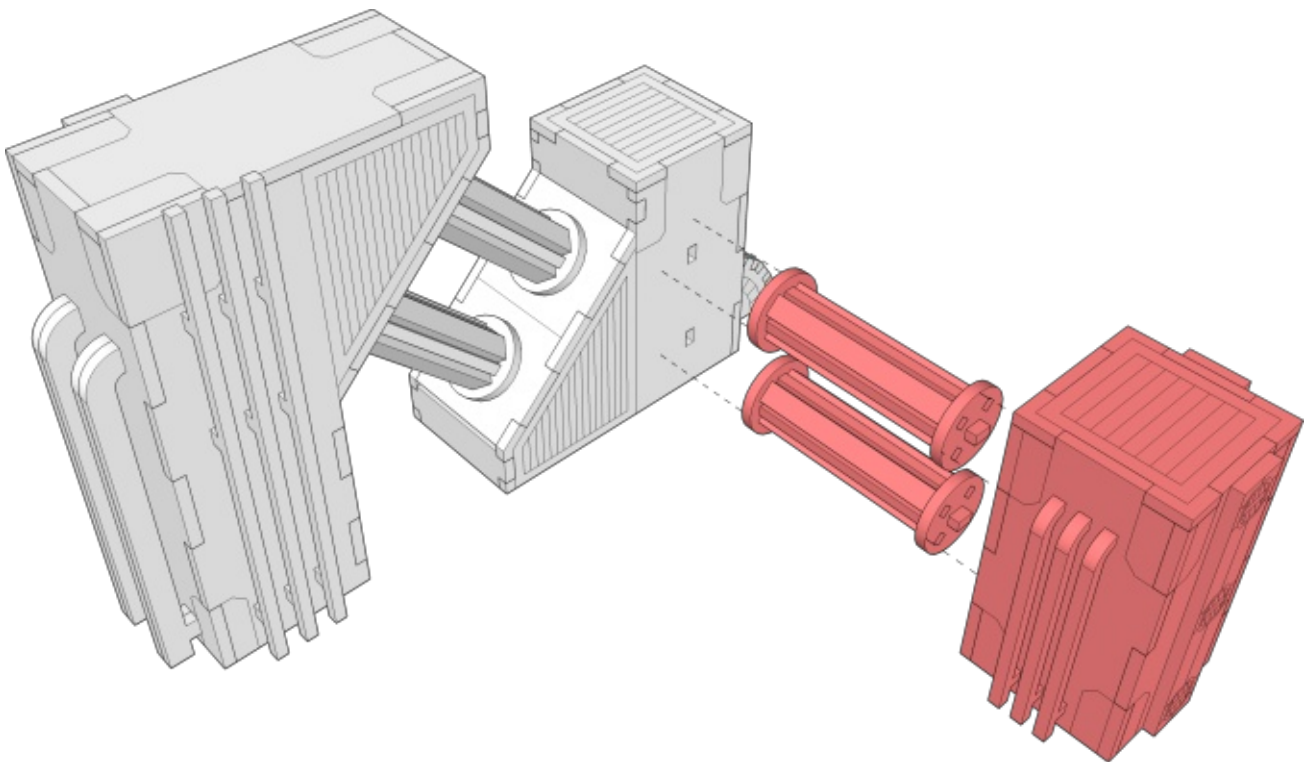



TABLETOP  
**SCENICS**

46

**TTSC-SFX-079**  
**Burton**  
**Quartersections**

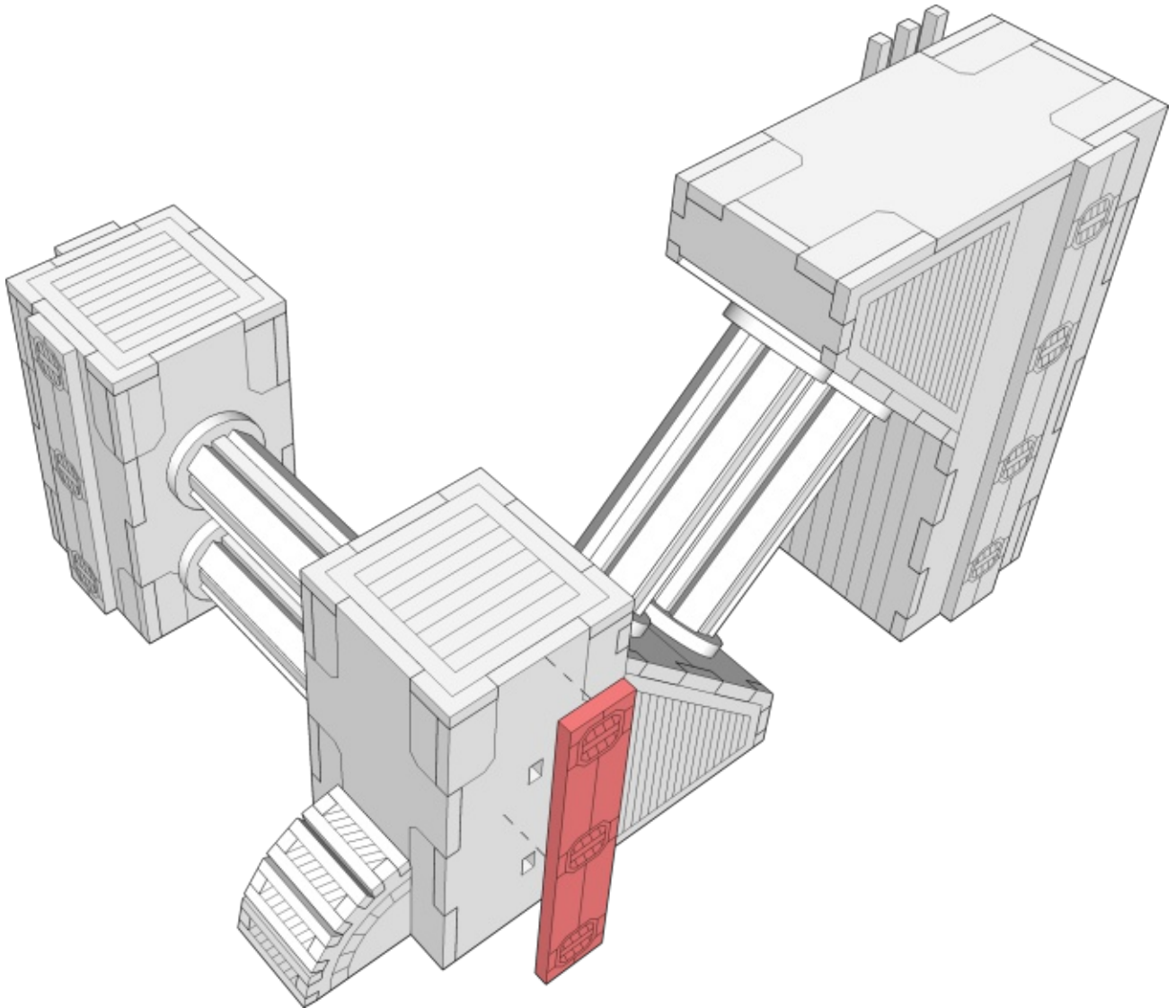



TABLETOP  
**SCENICS**

**47**

**TTSC-SFX-079**  
**Burton**  
**Quartersections**

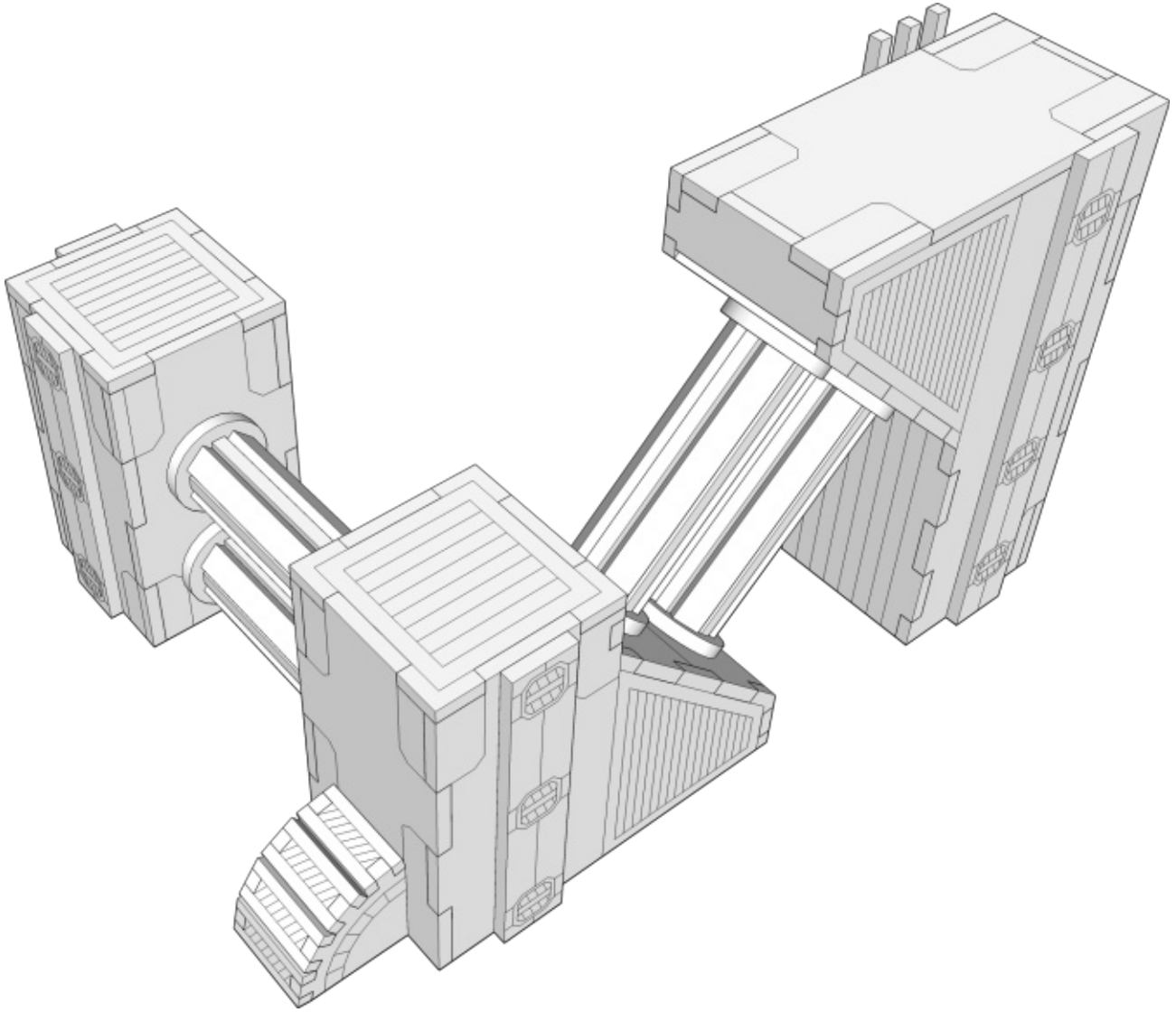

 **TTCOMBAT**



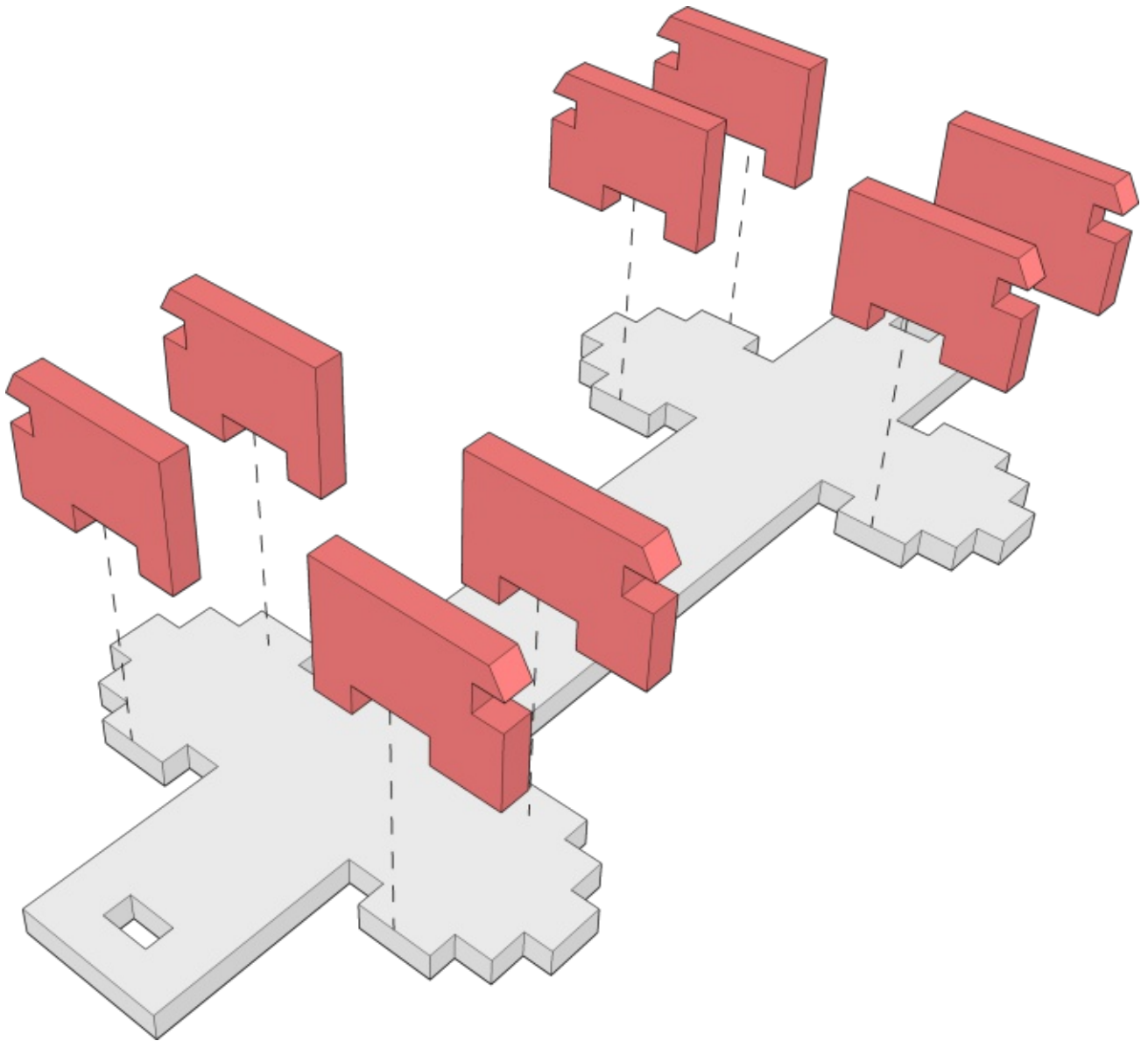

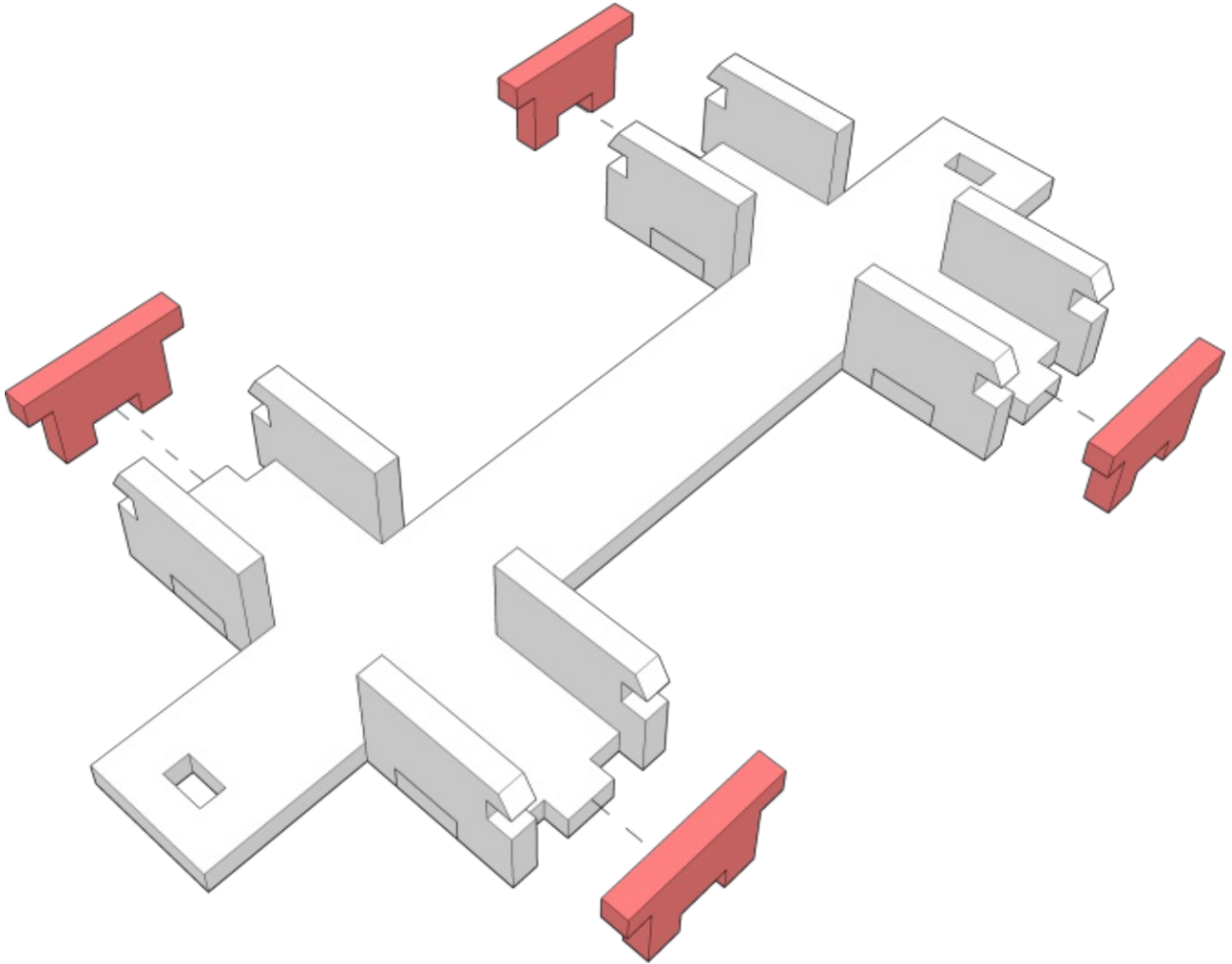

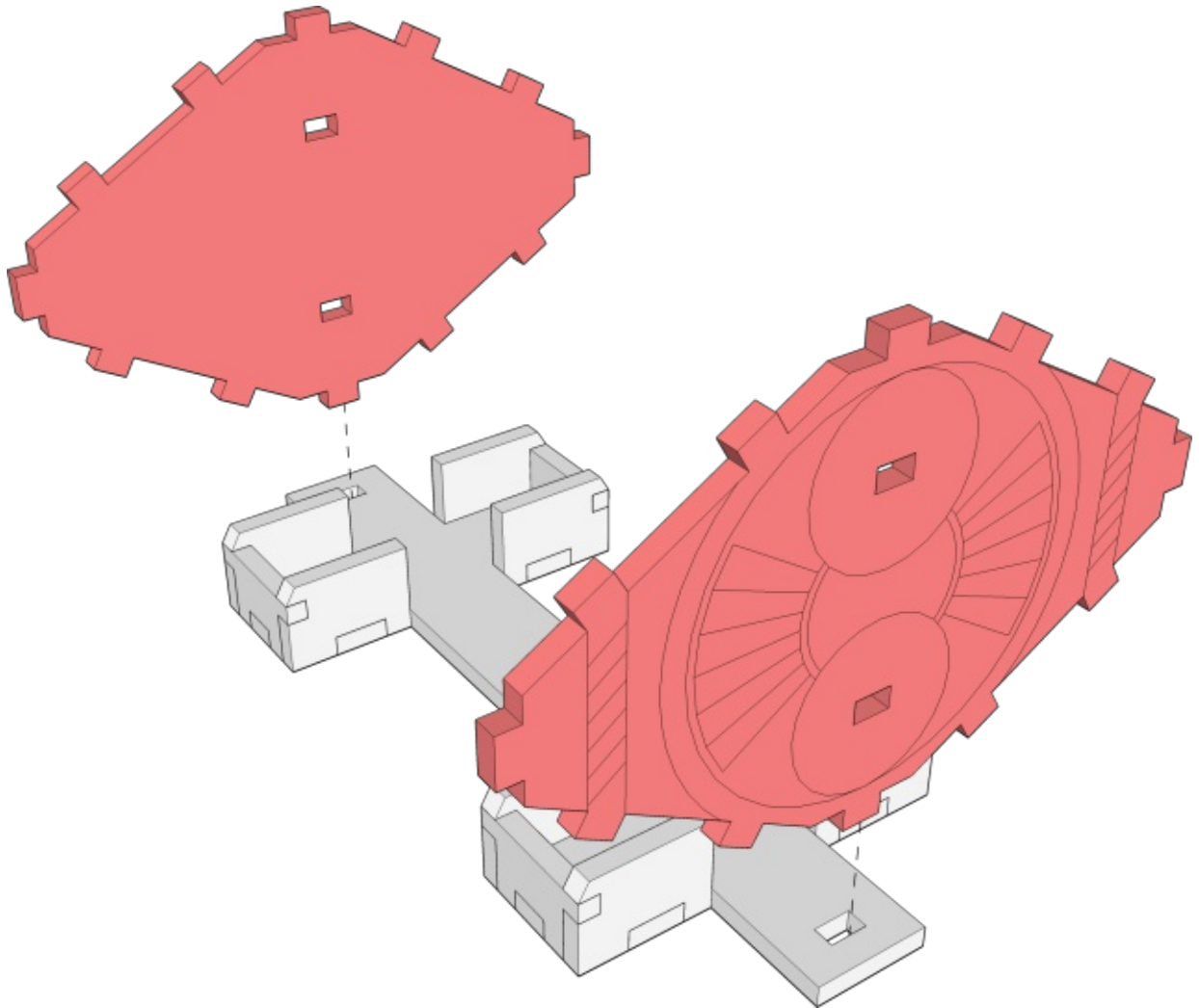

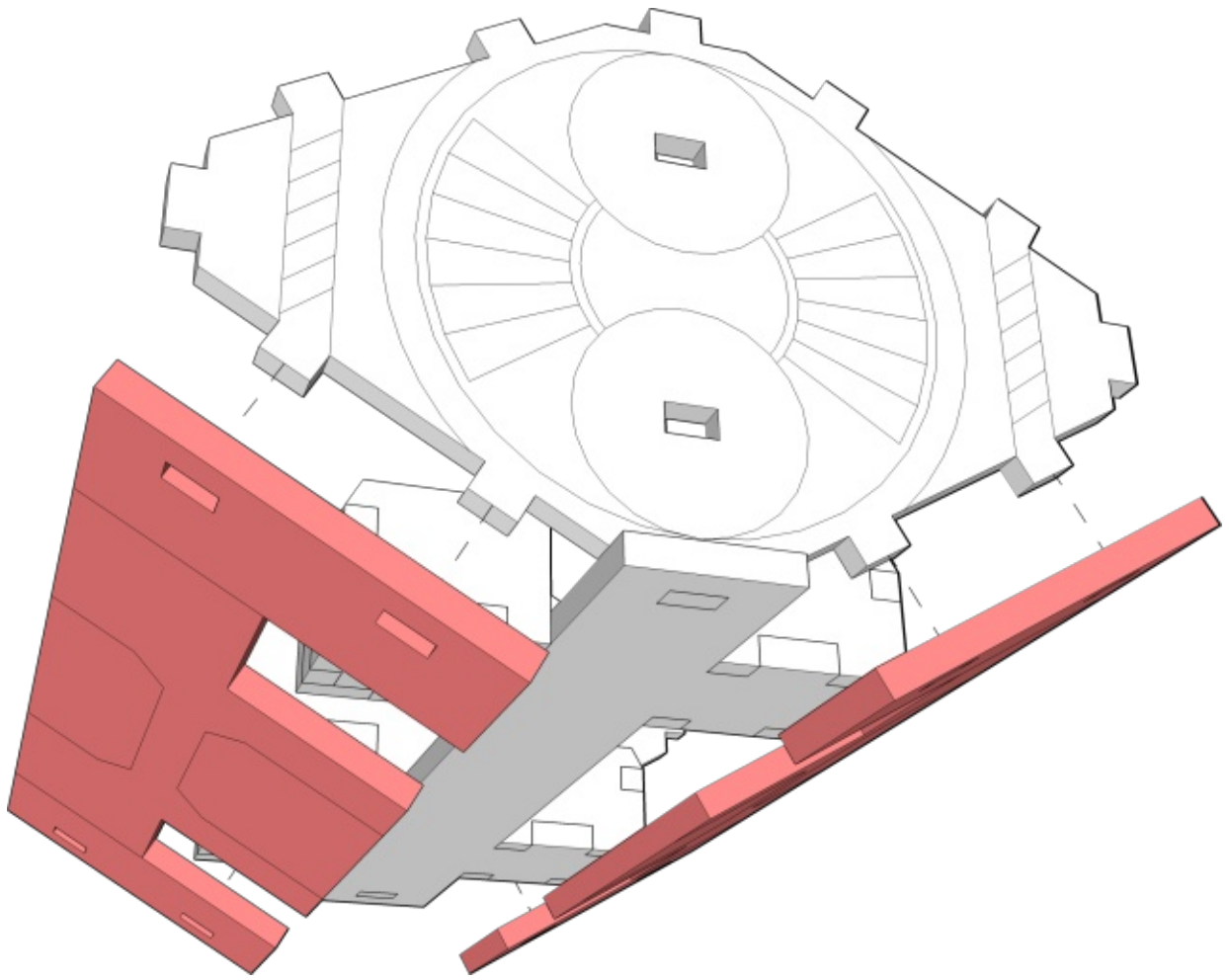

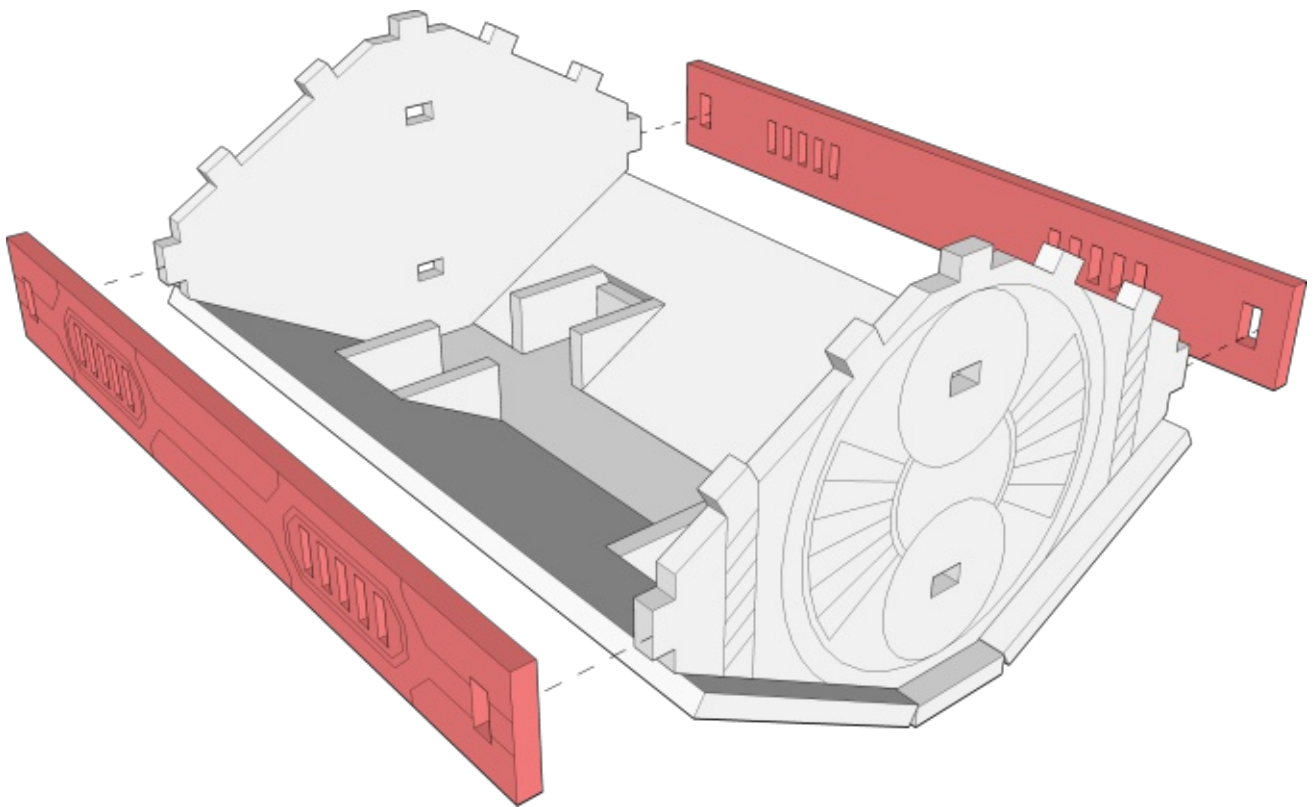

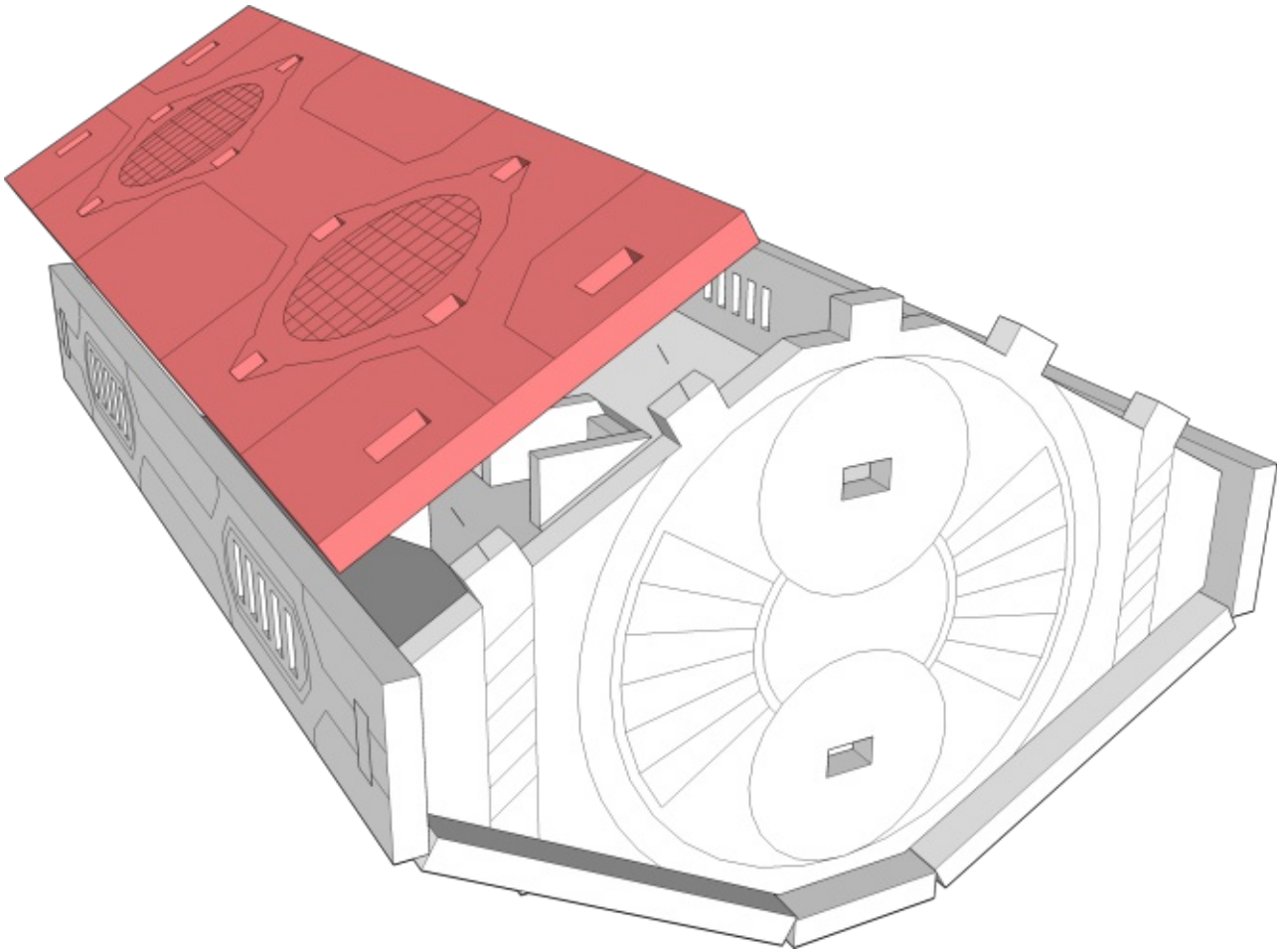

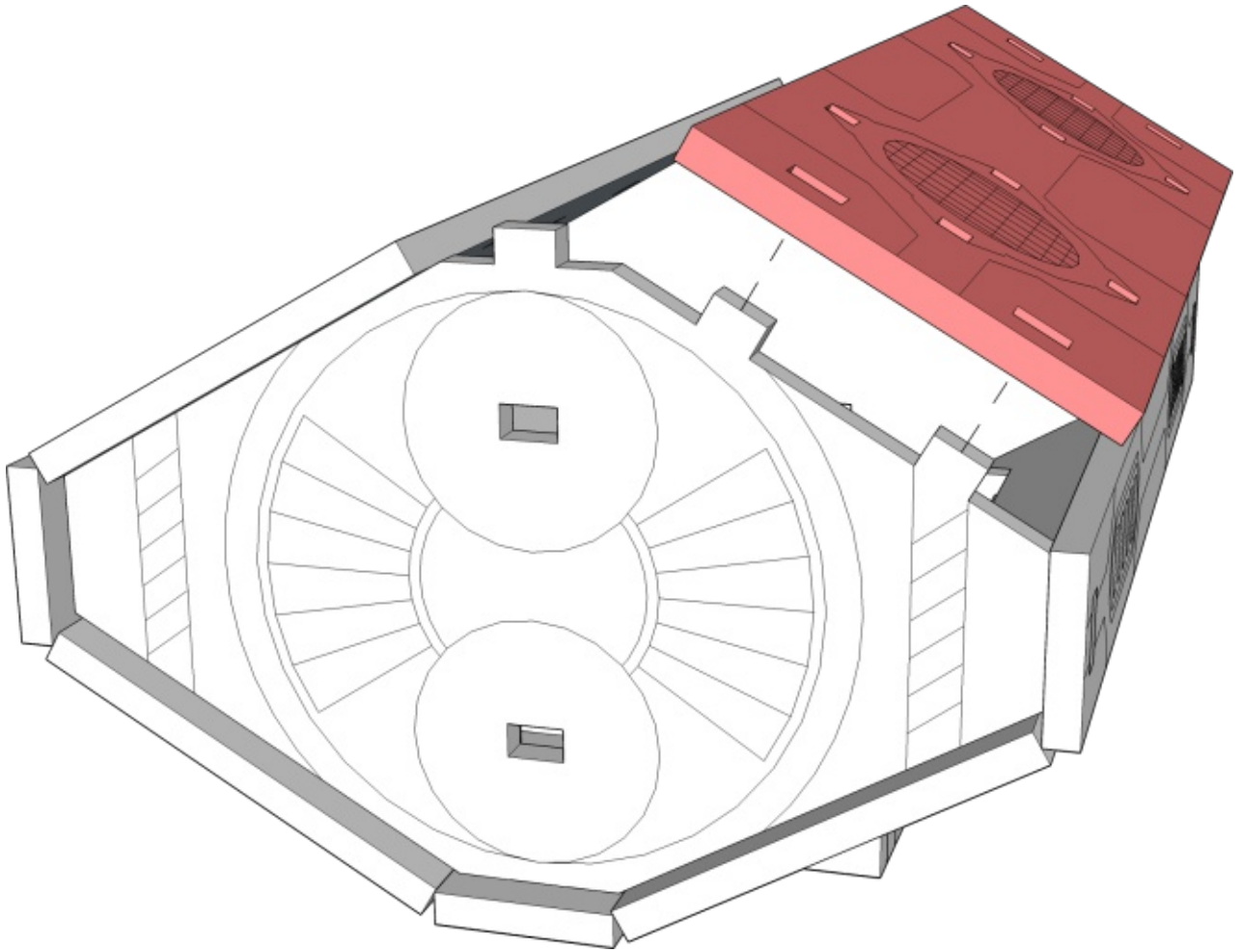

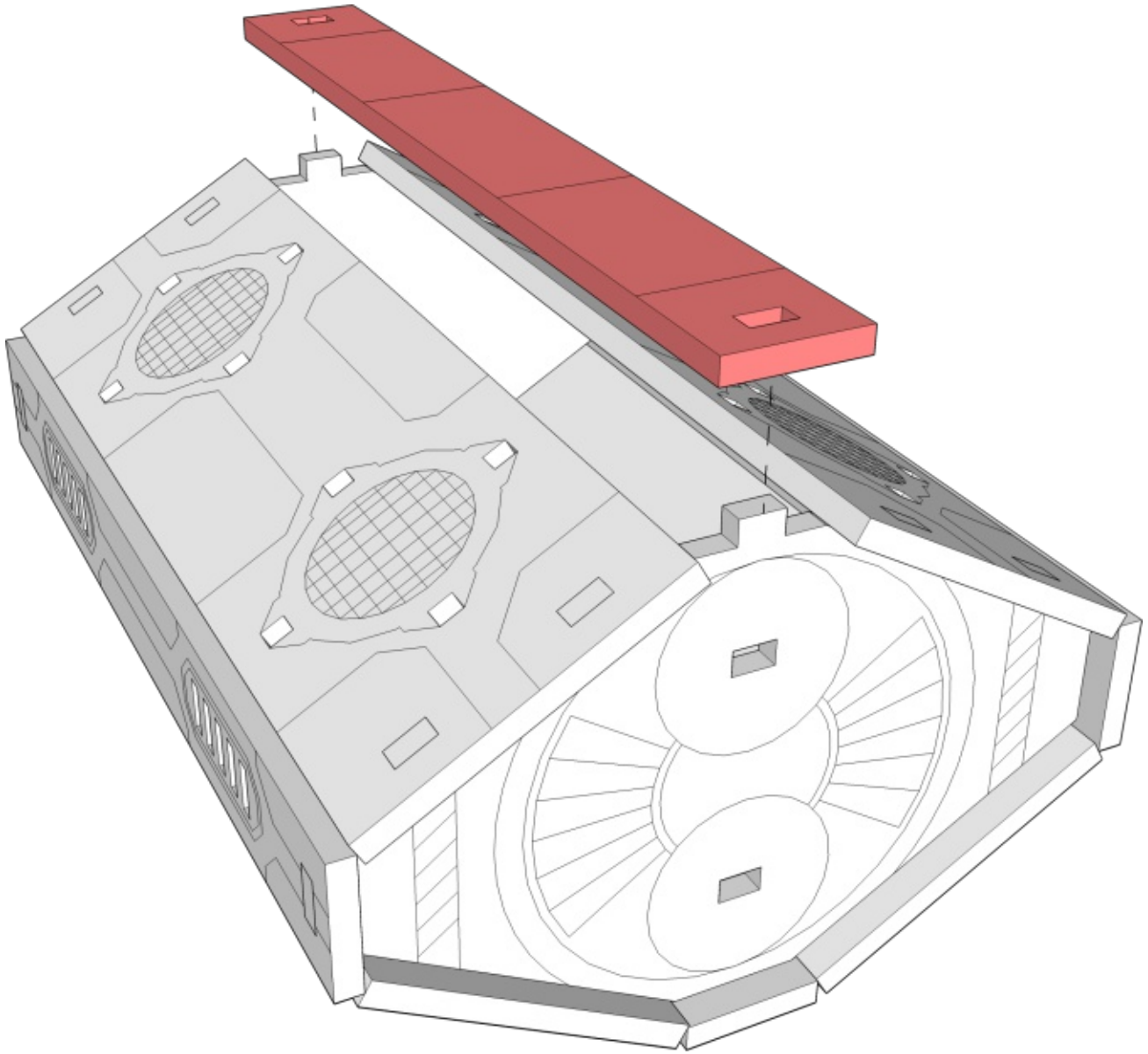



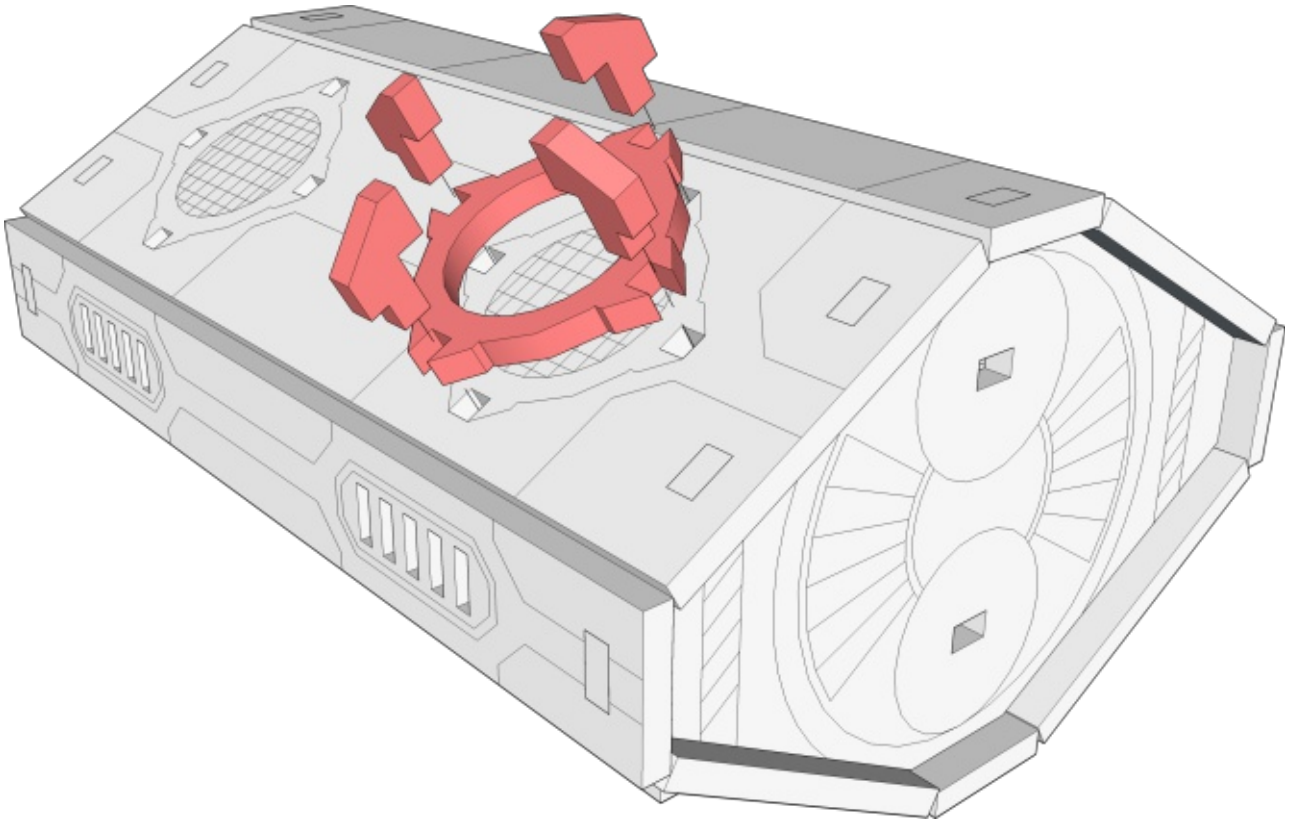

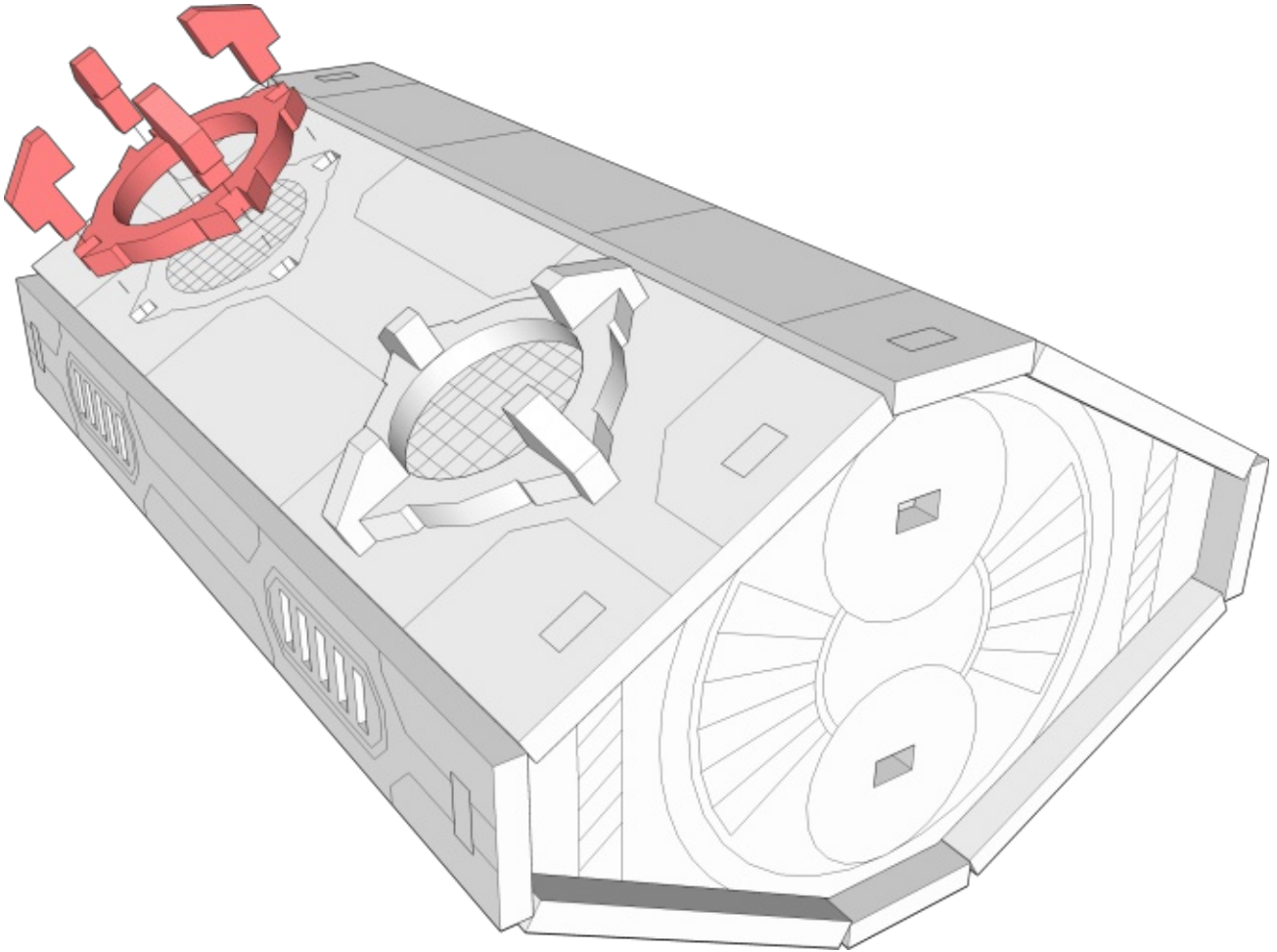

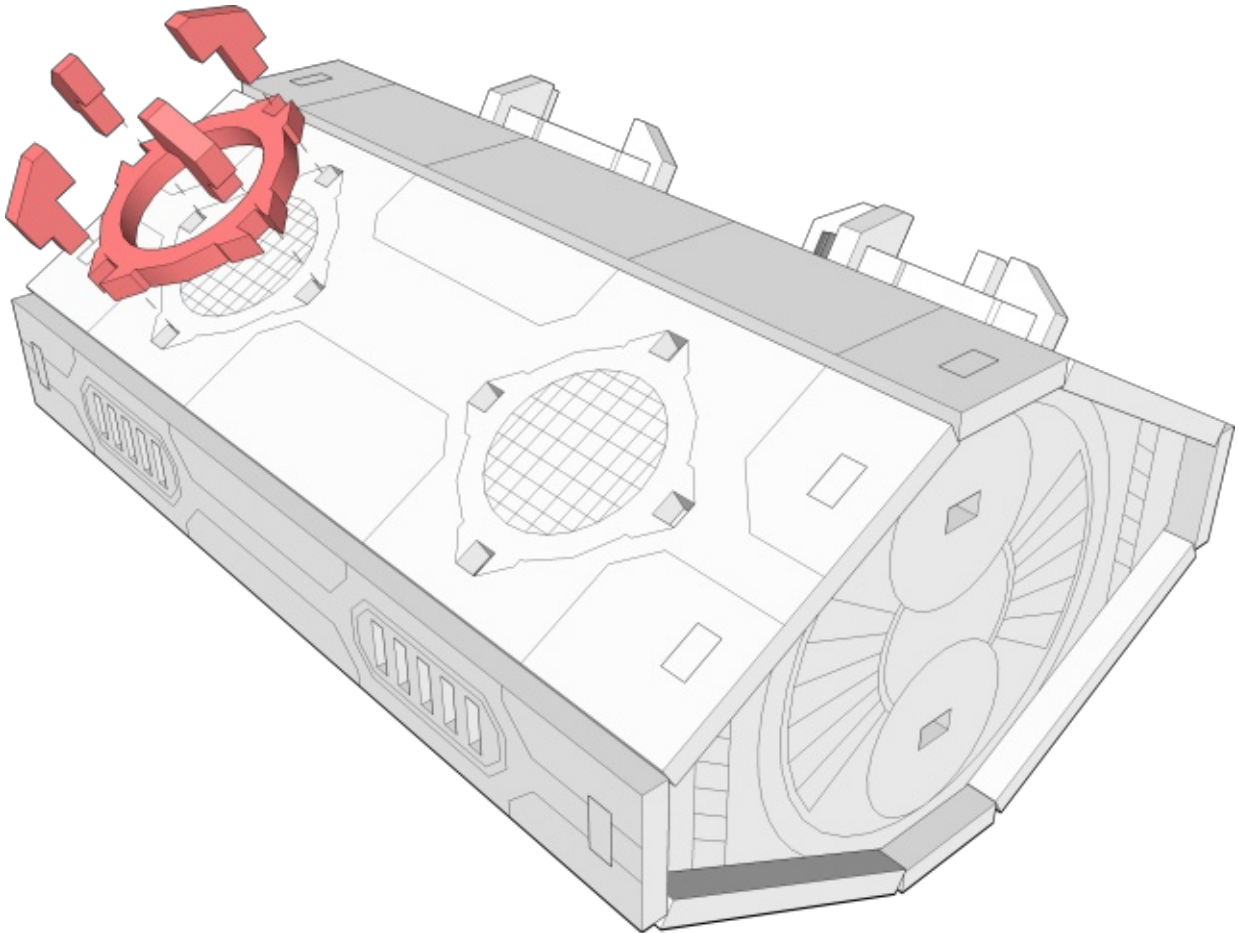

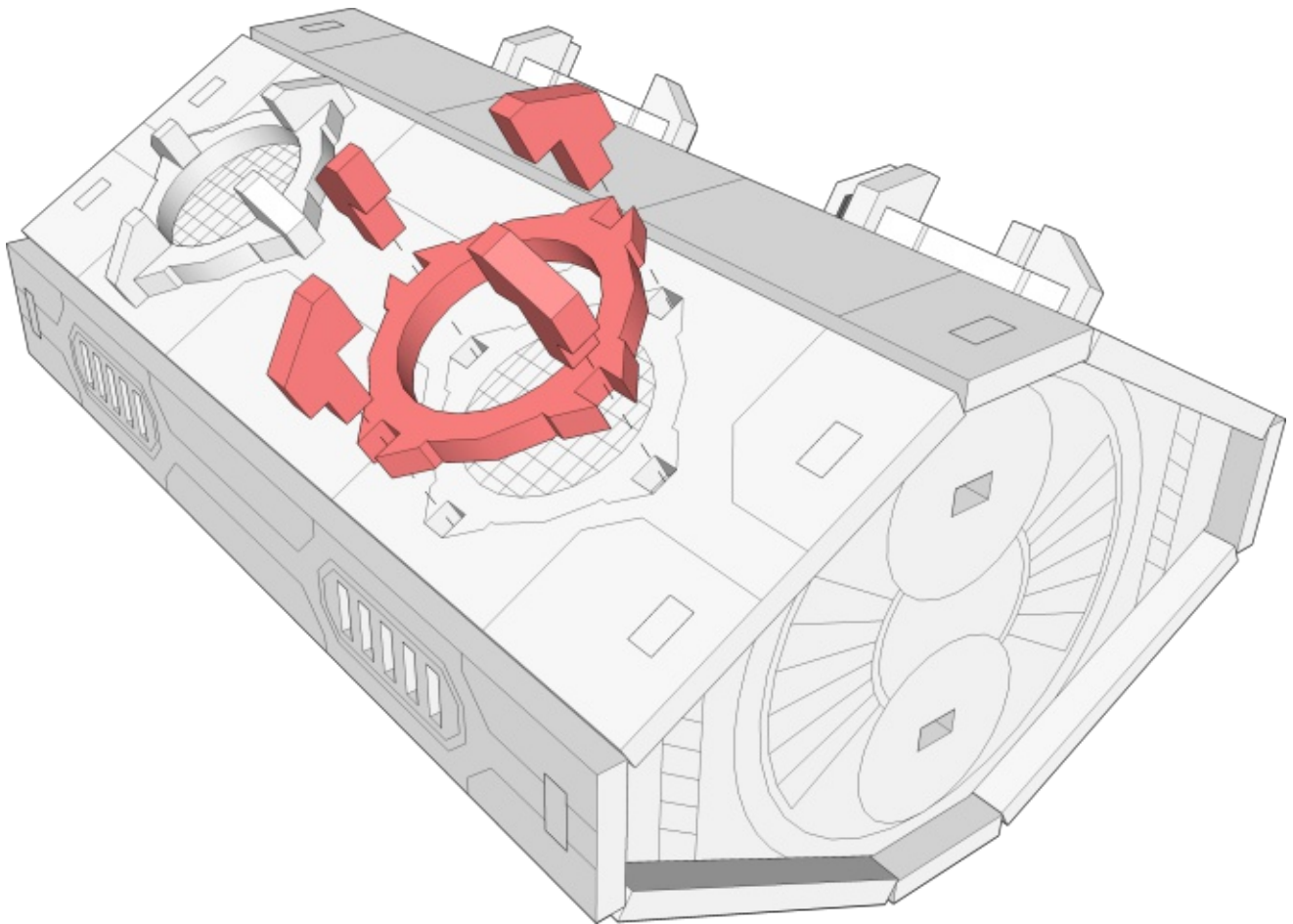



TABLETOP  
**SCENICS**

60

**TTSC-SFX-079**  
**Burton**  
**Quartersections**

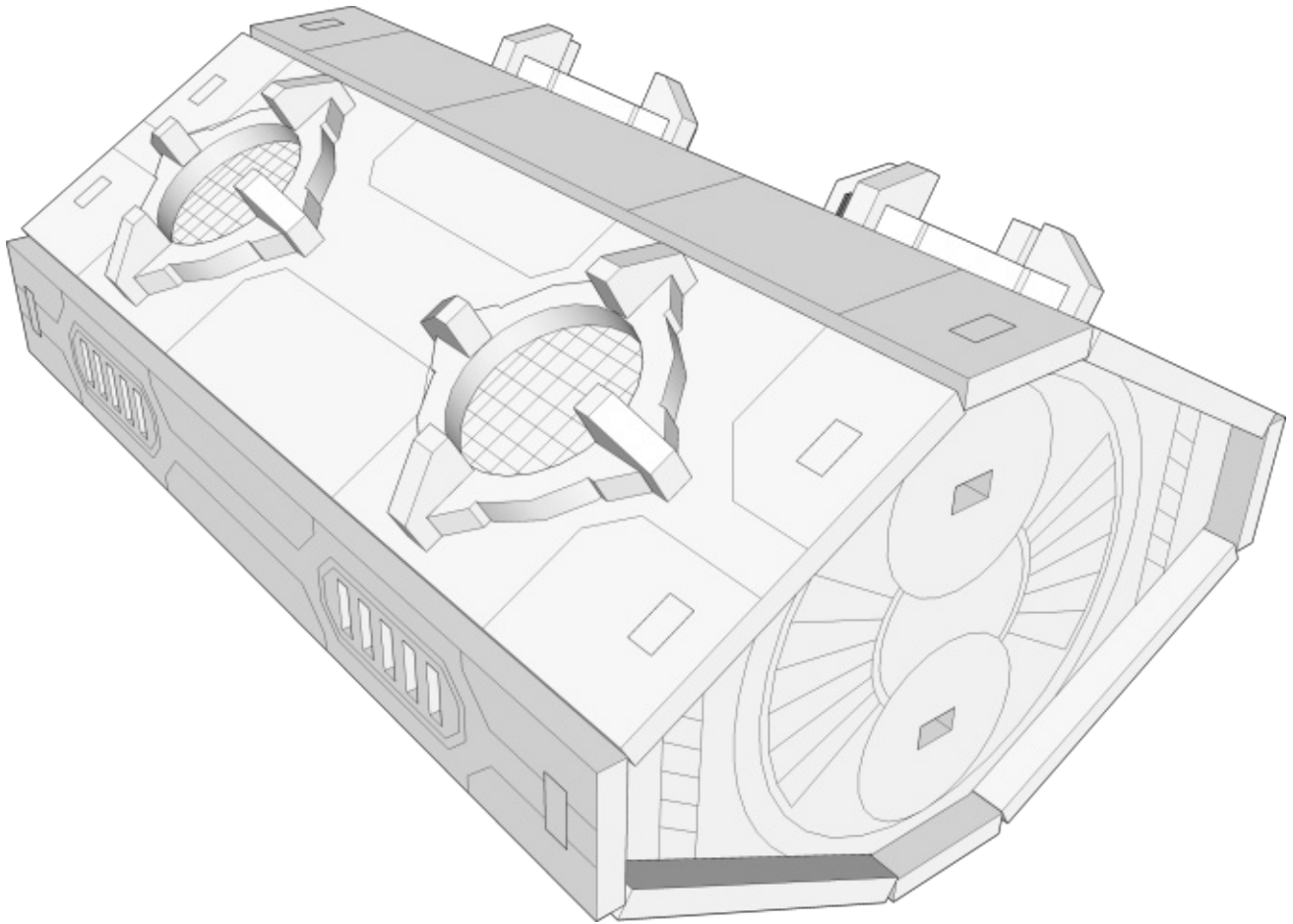

 **TTCOMBAT**

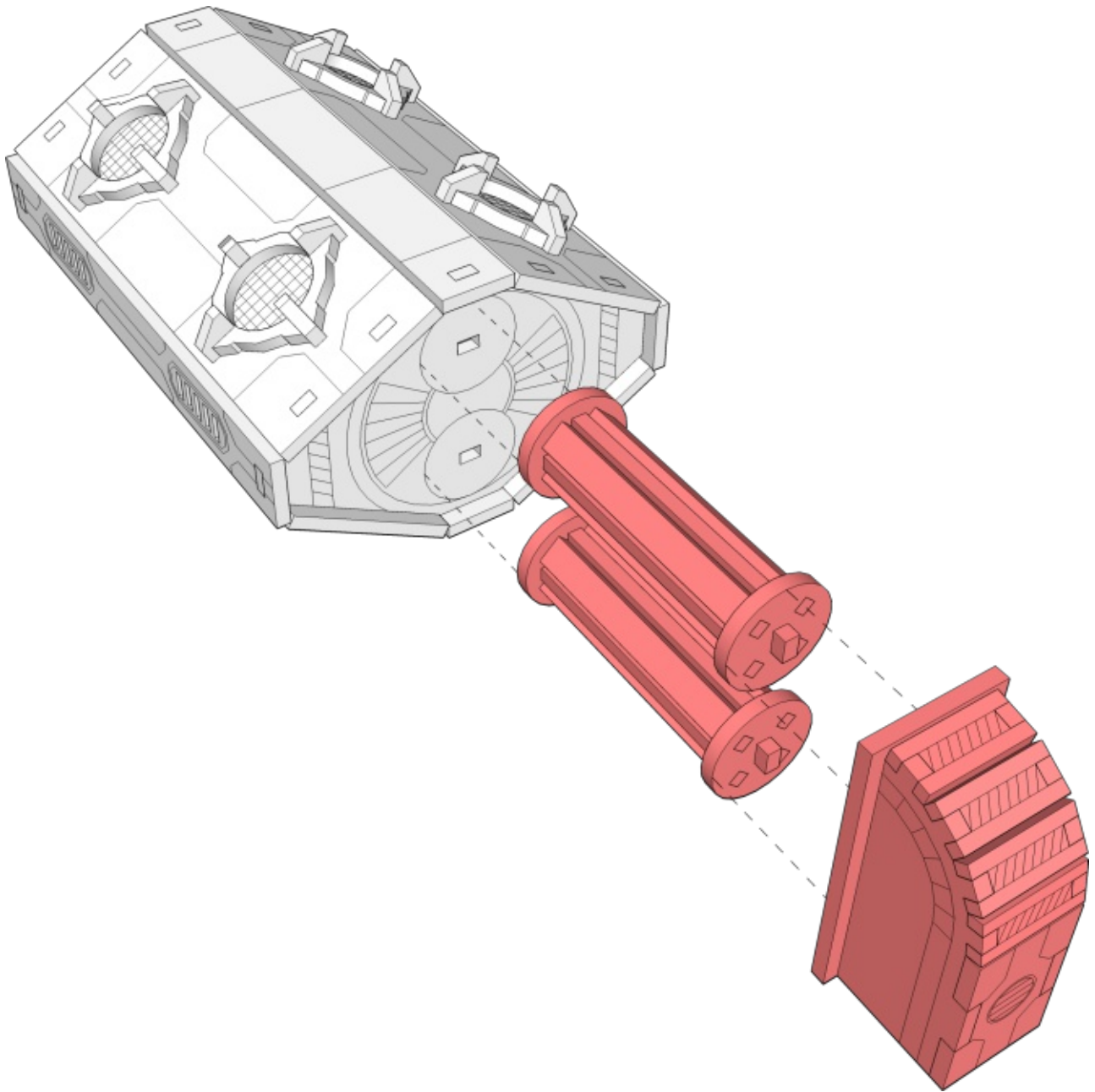



TABLETOP  
**SCENICS**

62

**TTSC-SFX-079**  
**Burton**  
**Quartersections**

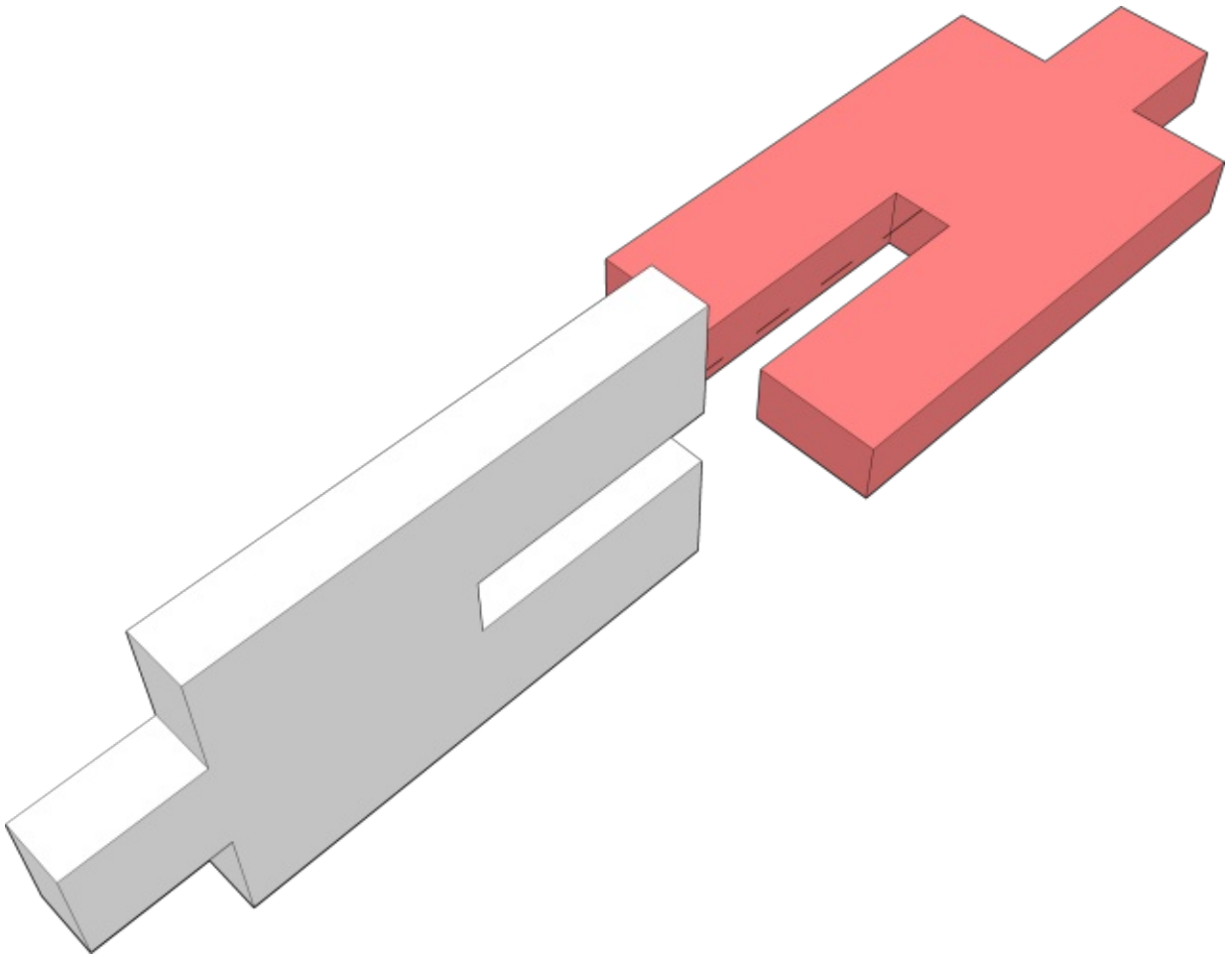

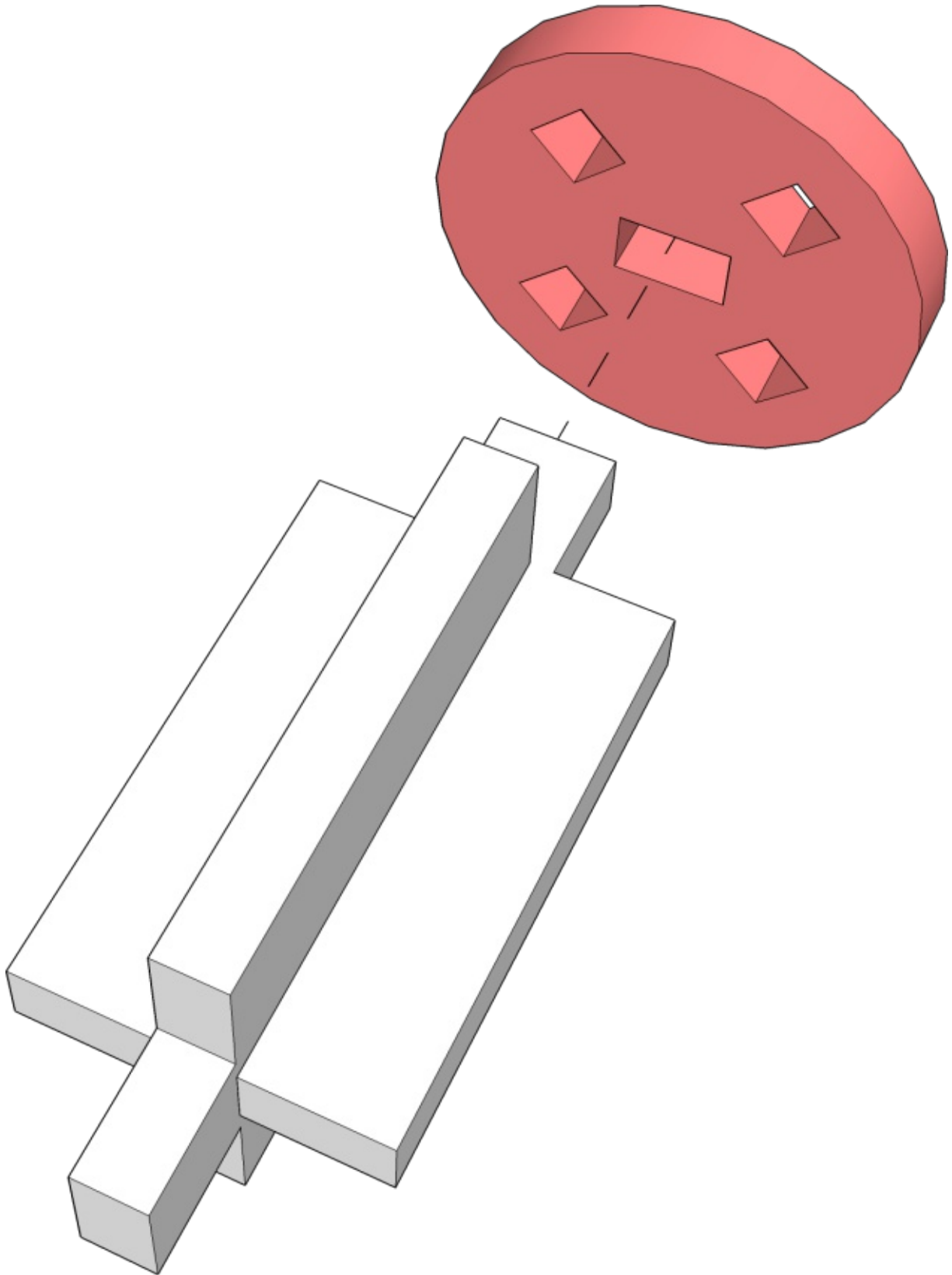





TABLETOP  
**SCENICS**

64

**TTSC-SFX-079**  
**Burton**  
**Quartersections**

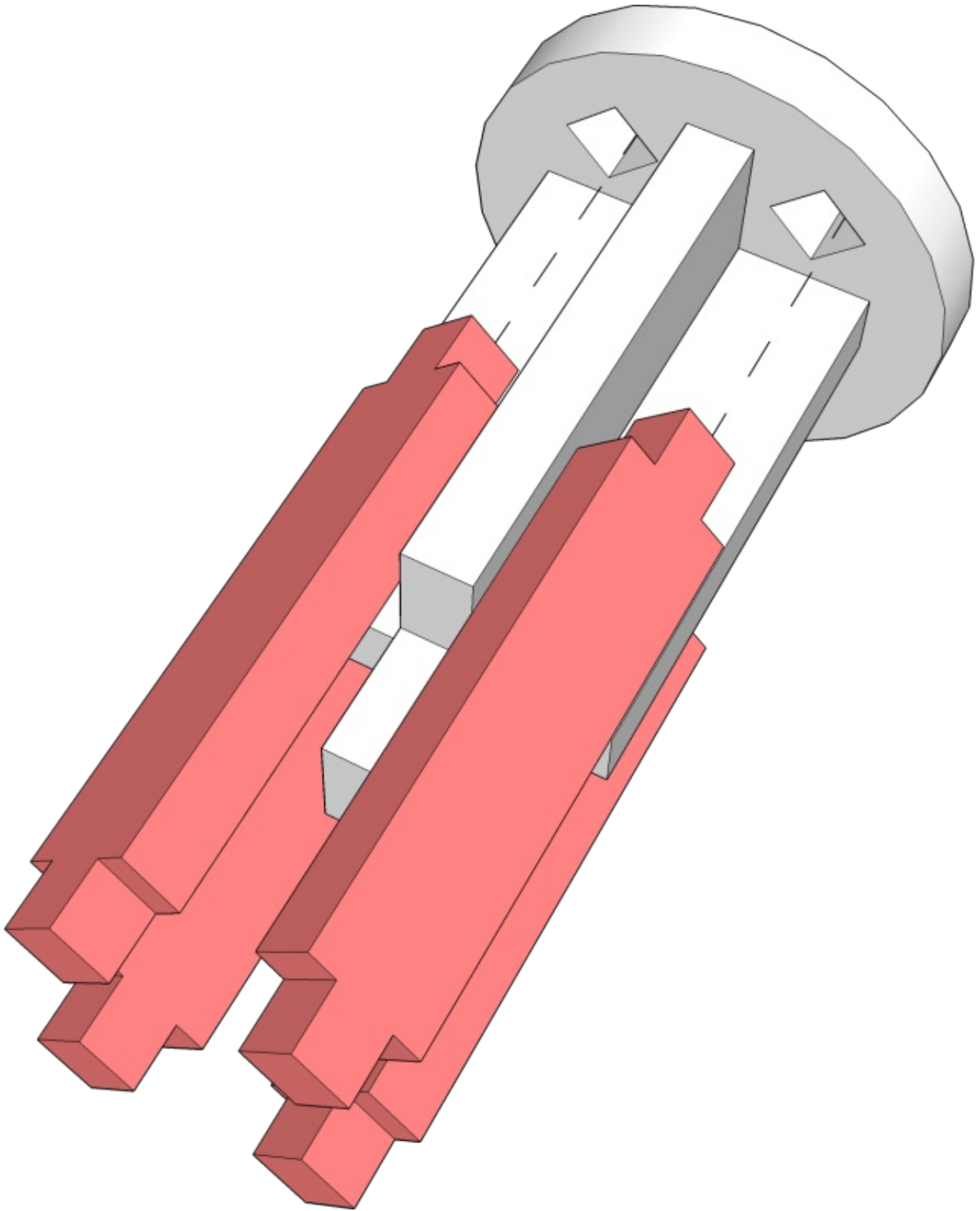

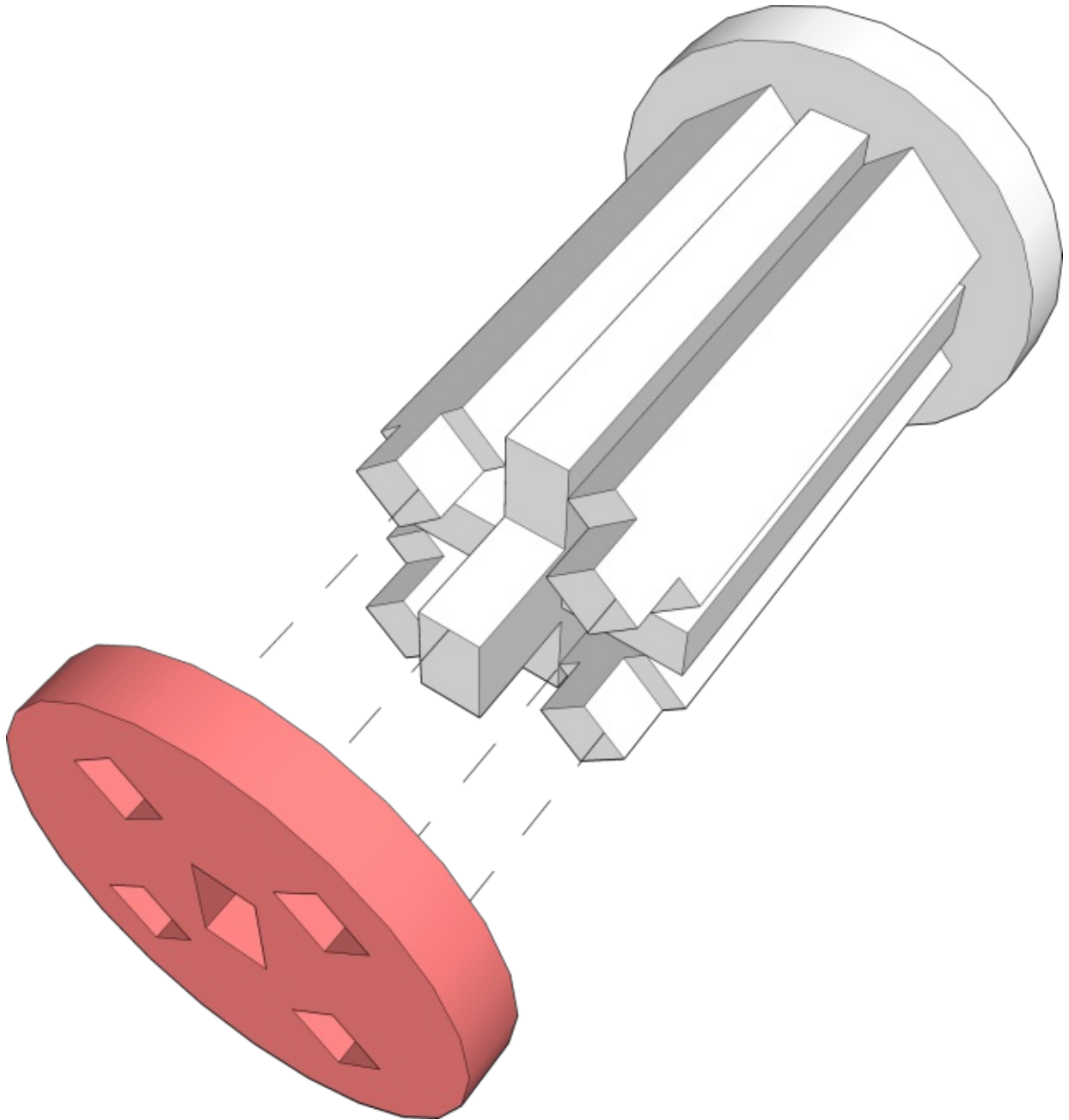



TABLETOP  
**SCENICS**

66

**TTSC-SFX-079**  
**Burton**  
**Quartersections**

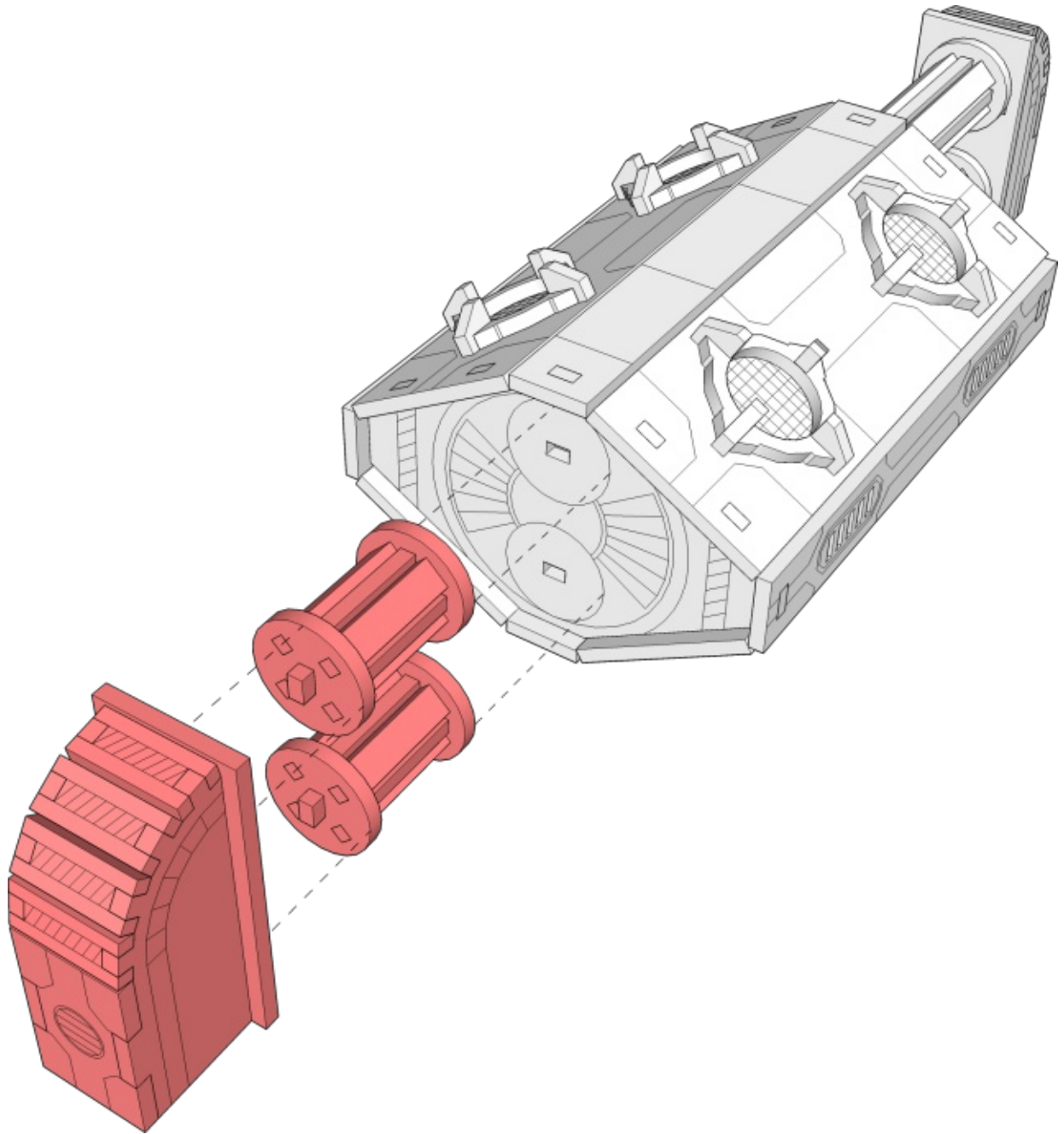



TABLETOP  
**SCENICS**

67

**TTSC-SFX-079**  
**Burton**  
**Quartersections**

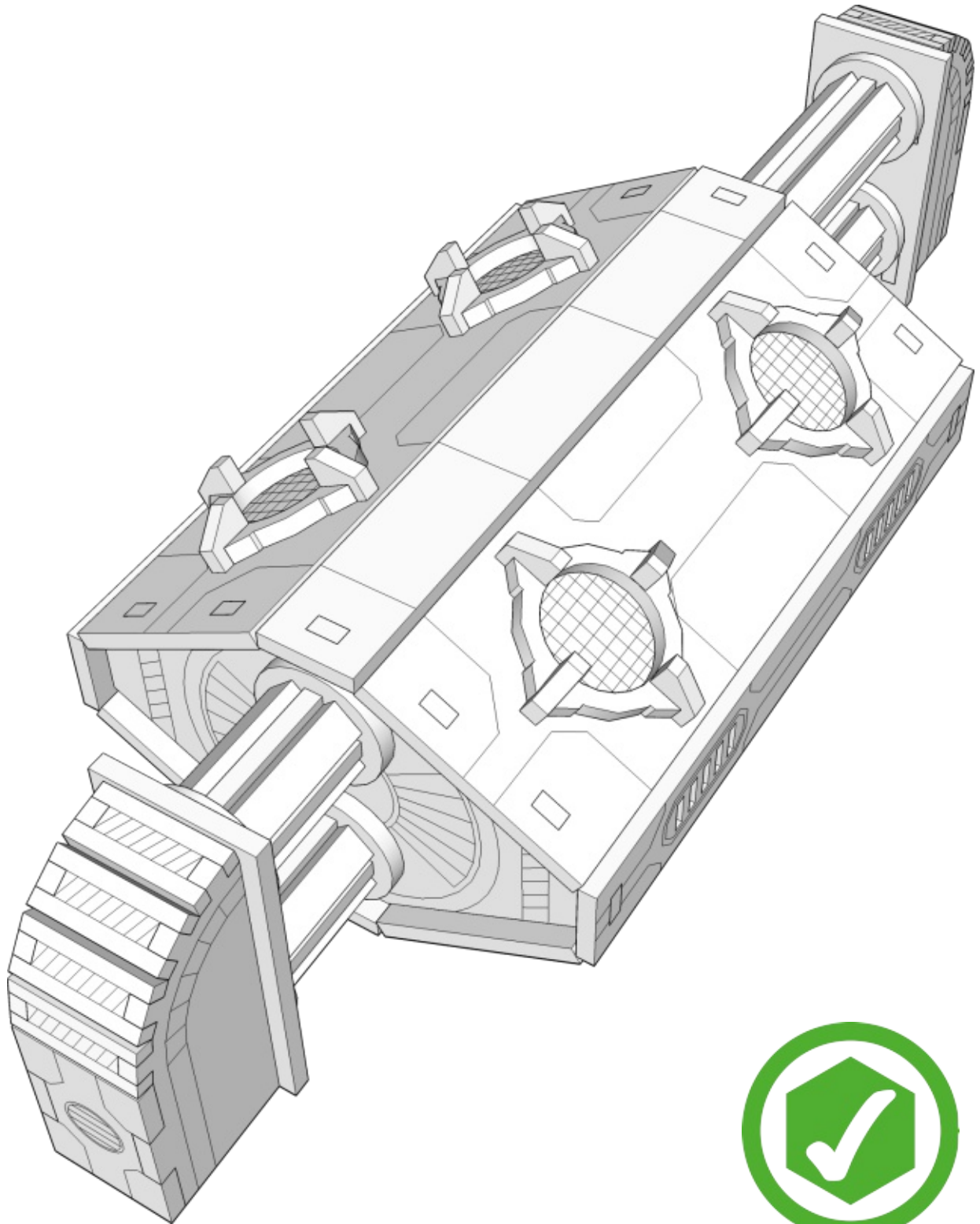

 **TTCOMBAT**