

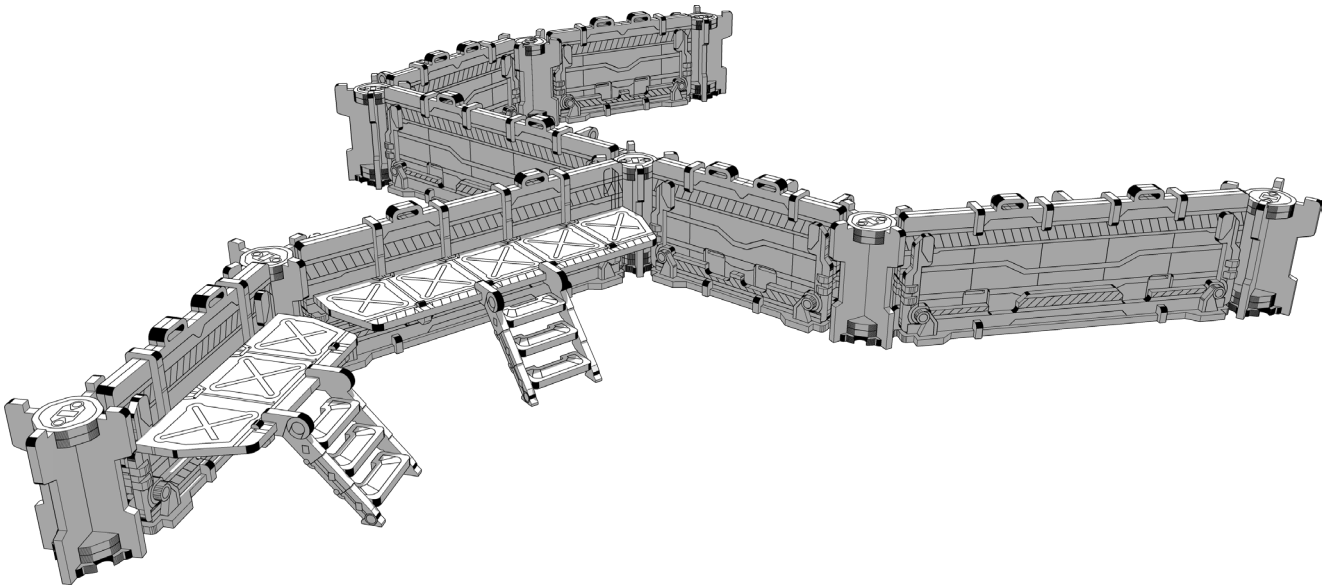

**TABLETOP
SCENICS**

**TTSCW-SFU-151
QDSC
Fences**



 **TTCOMBAT**



TABLETOP SCENICS

TTSCW-SFU-151
QDSC
Fences

2

These are a series of icons that may be used throughout the instructions to help your assembly.
If in doubt, scroll ahead to confirm.



Do not glue this part



Carefully score and
fold this part

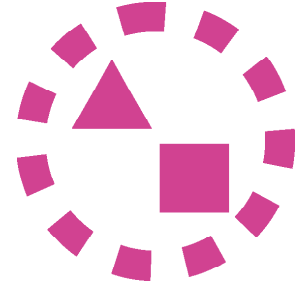

This part - or its placement is
completely optional

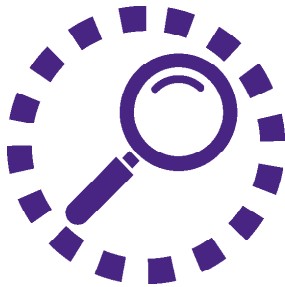

Look closely at this step -
The process order or part
used, may be specific



Repeat making this part
the specified number
of times

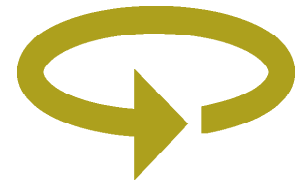

The next instruction step
will be the same assembly
so far, but from a different
angle

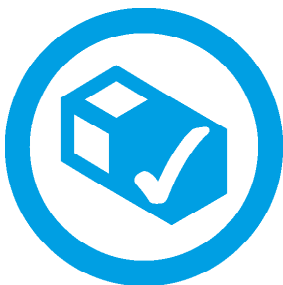

Sub-assembly complete.
This smaller construction
is ready to add to the
main kit



Assembly Complete! There
could be more optional
parts - check to the very end
of instructions



FRAGILE: DO NOT BEND.
“Bendy wood” is designed to
curve around a designed
frame only.



TABLETOP SCENICS

TTSCW-SFU-151
QDSC
Fences

3

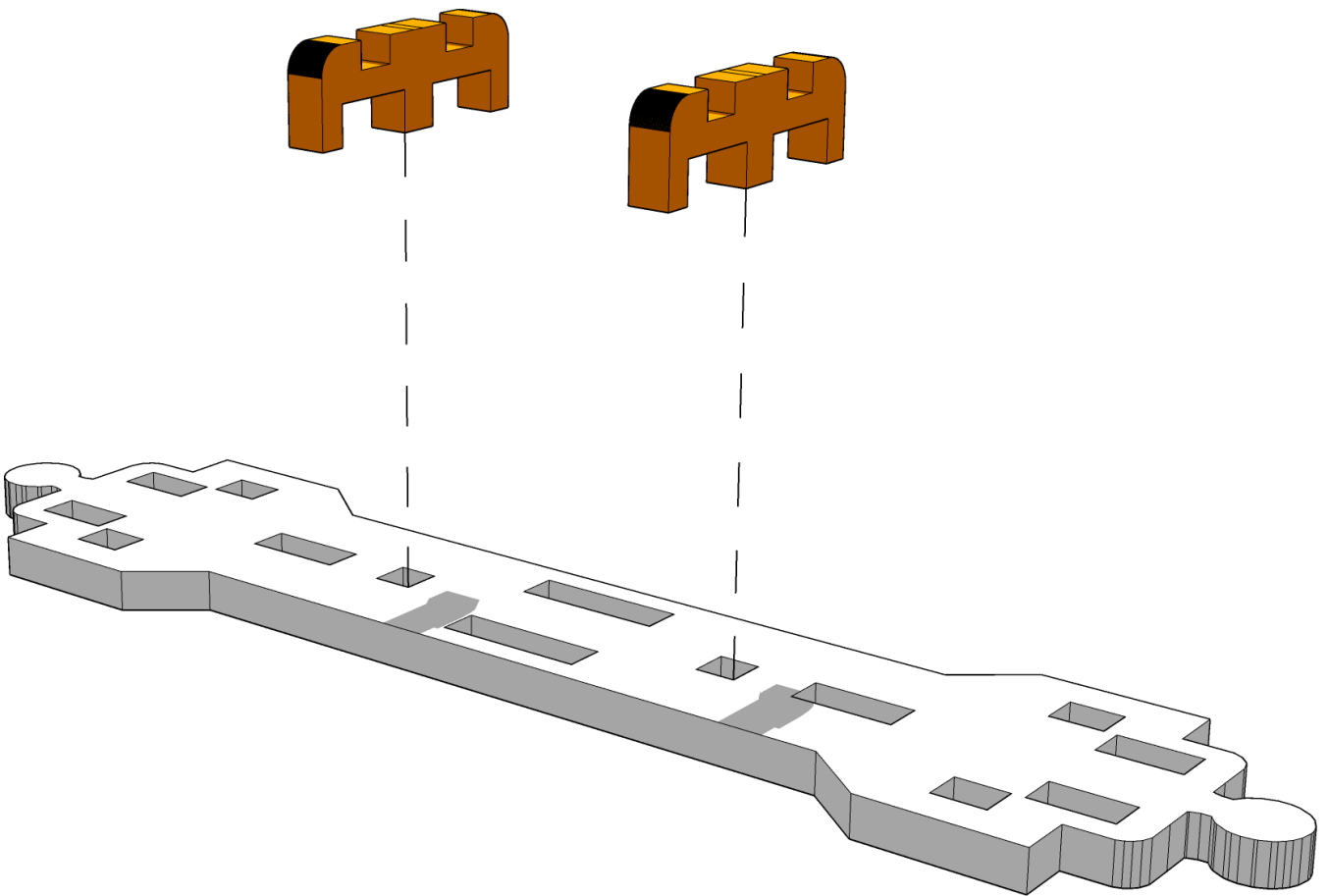



TABLETOP SCENICS

TTSCW-SFU-151
QDSC
Fences

4

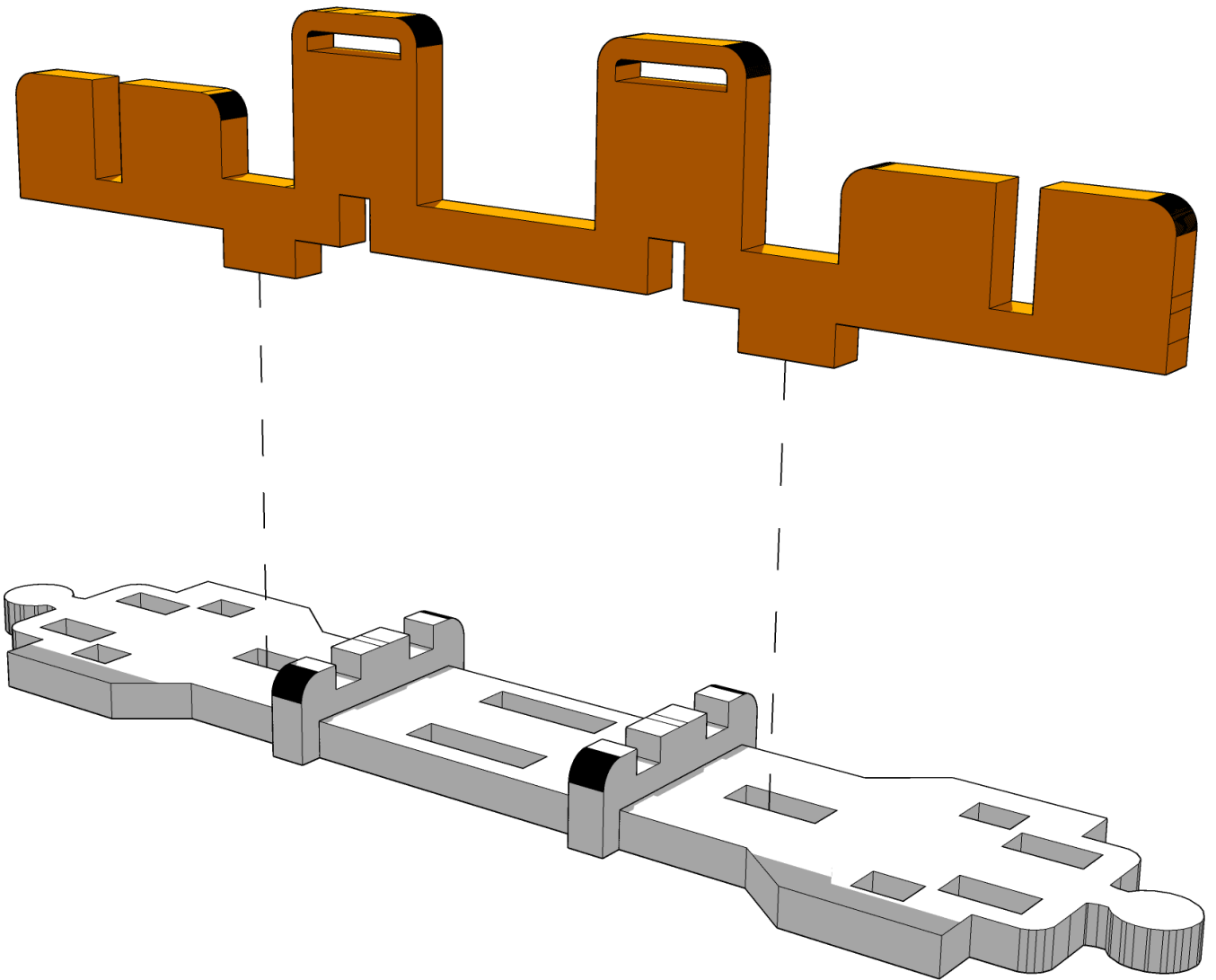



TABLETOP SCENICS

TTSCW-SFU-151
QDSC
Fences

5

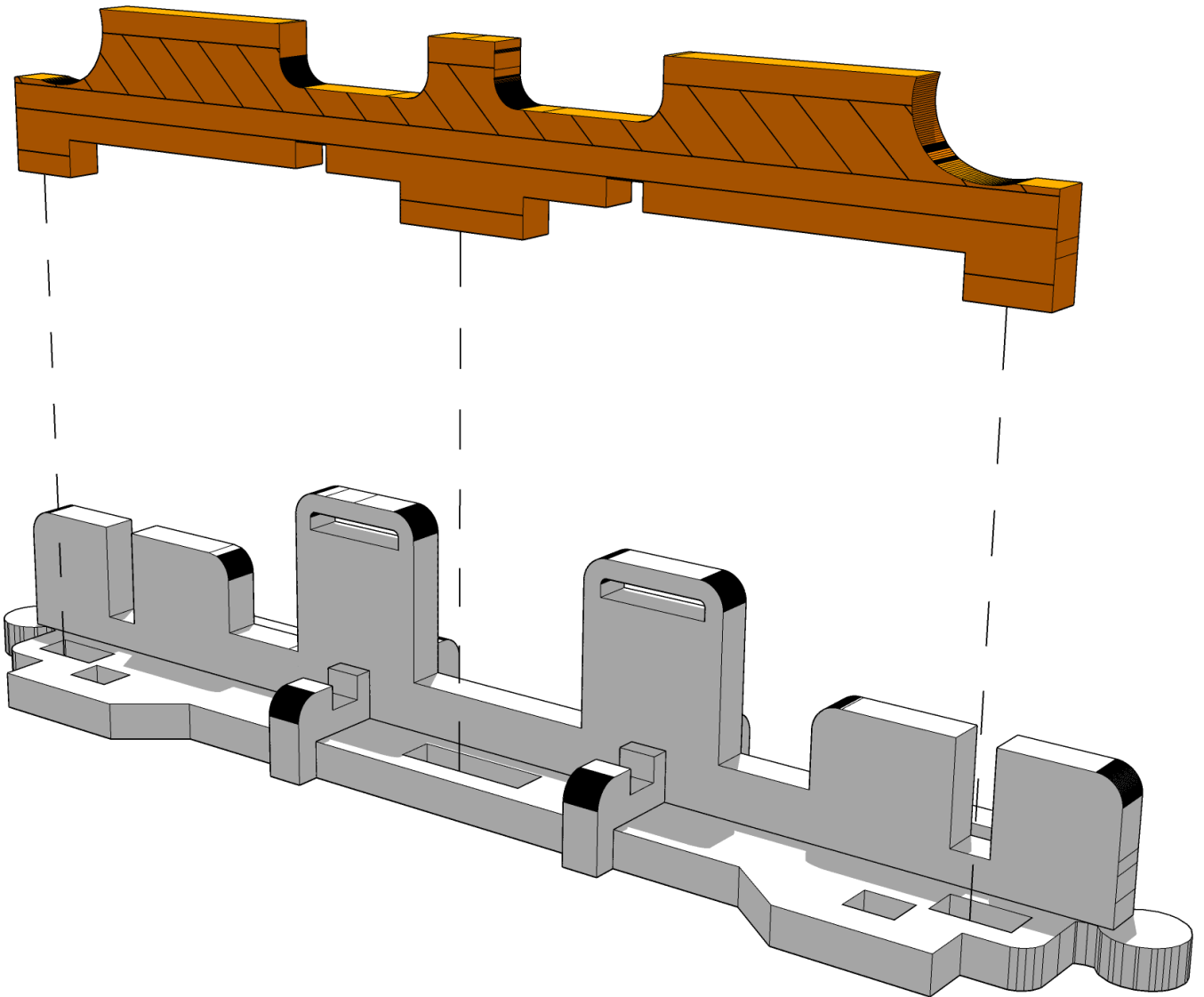



TABLETOP SCENICS

TTSCW-SFU-151
QDSC
Fences

6

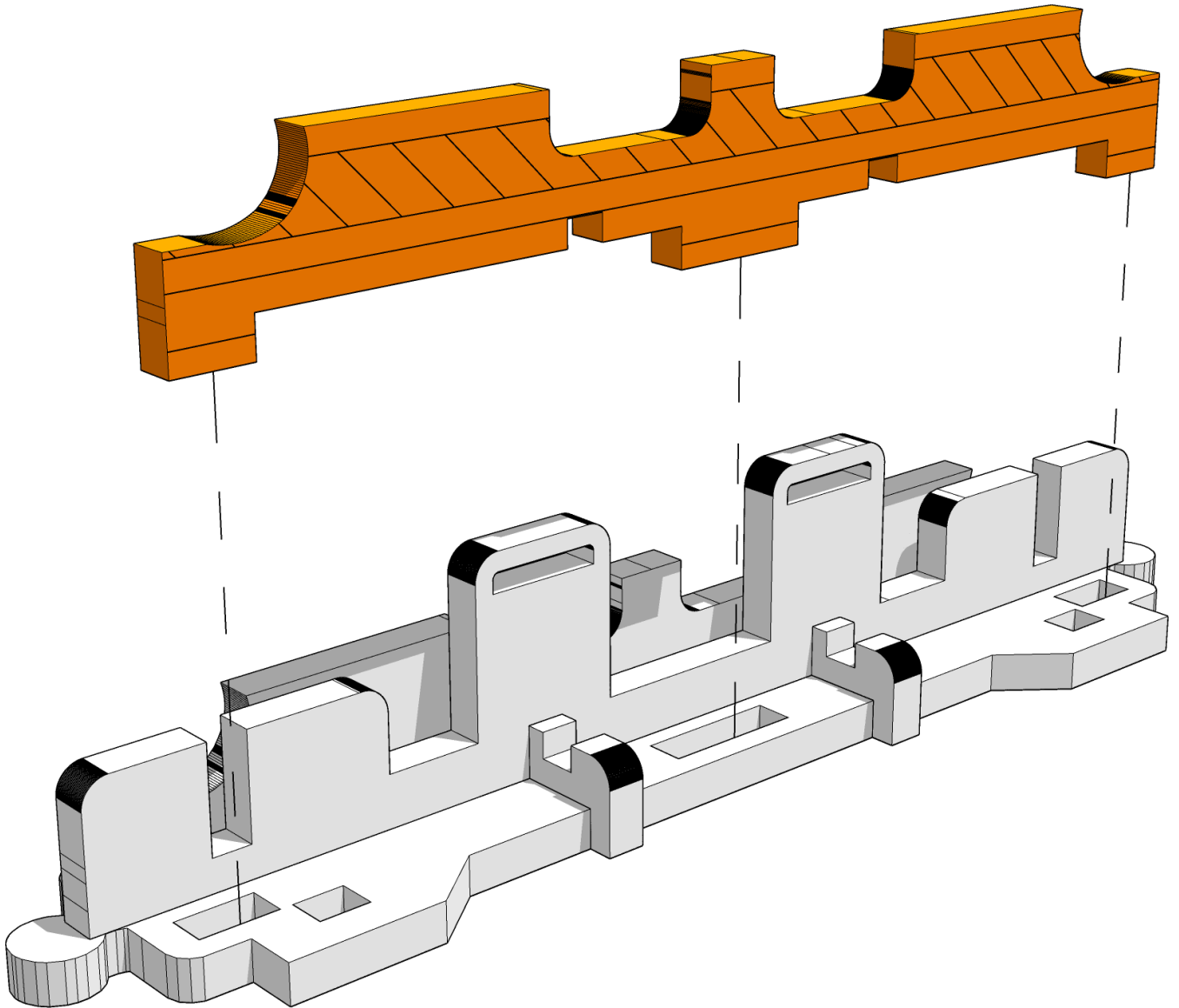



TABLETOP SCENICS

TTSCW-SFU-151
QDSC
Fences

7

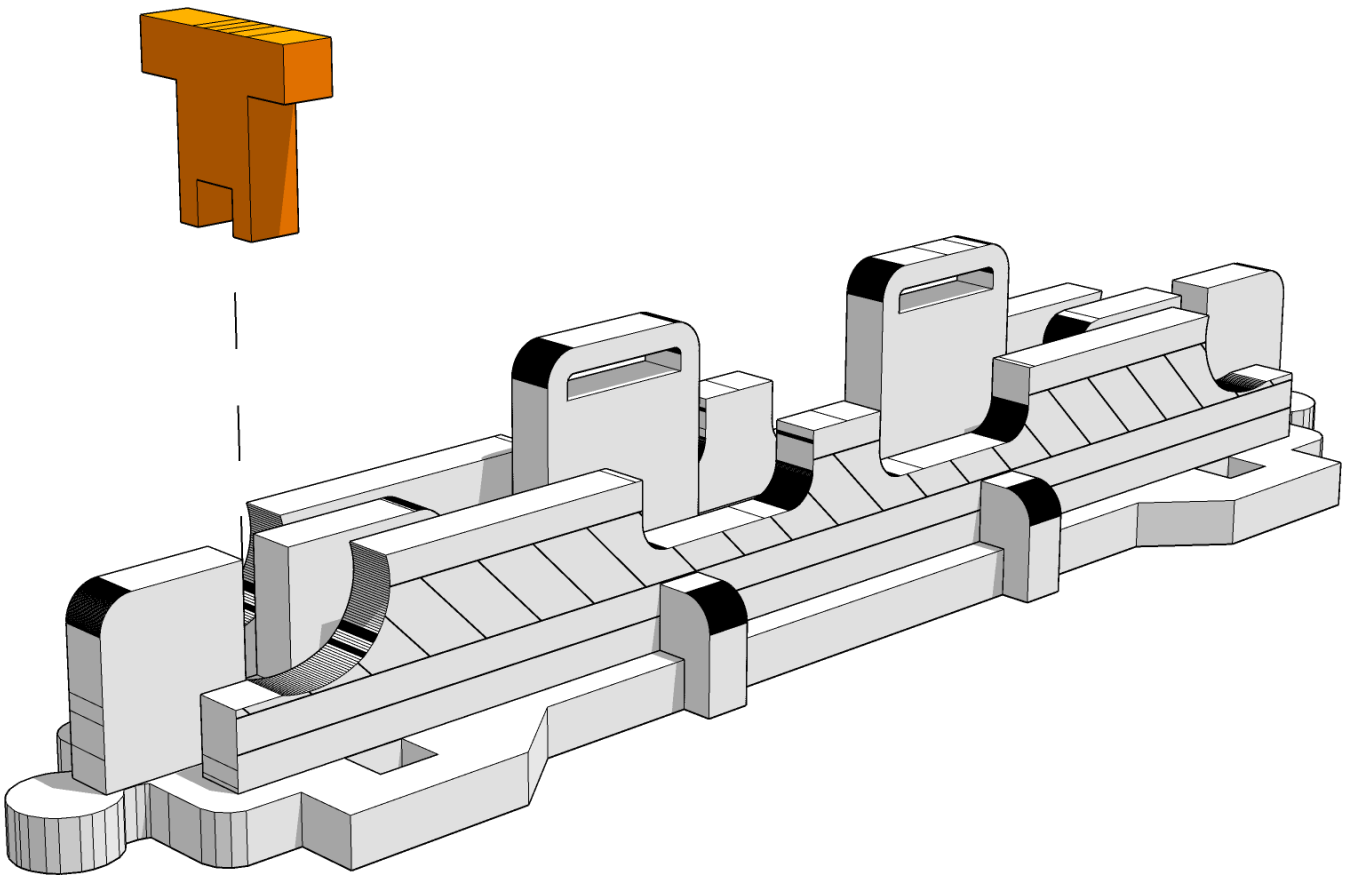



8

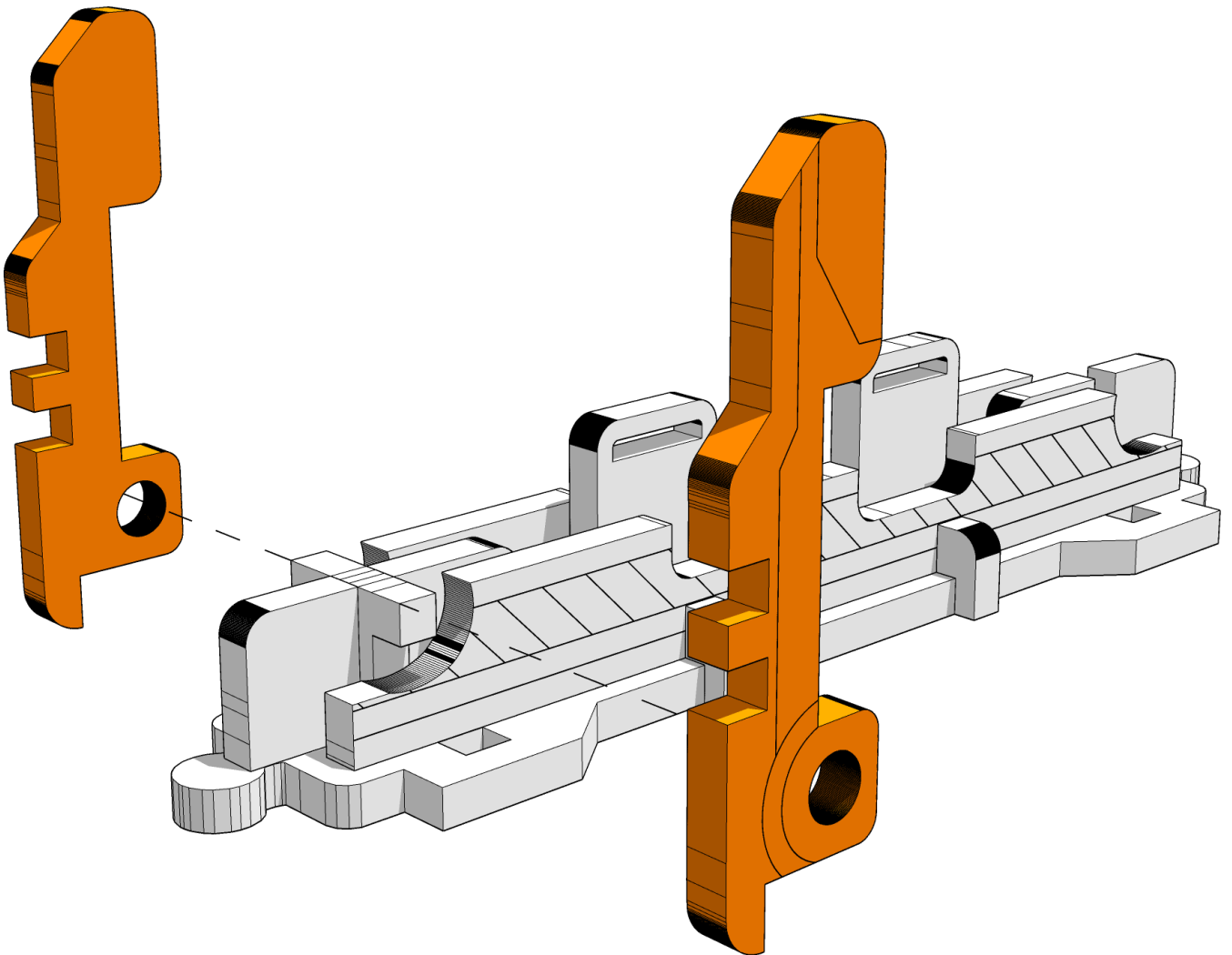

Highlighted parts are the shorter version.
Place into position only





TABLETOP SCENICS

TTSCW-SFU-151
QDSC
Fences

9

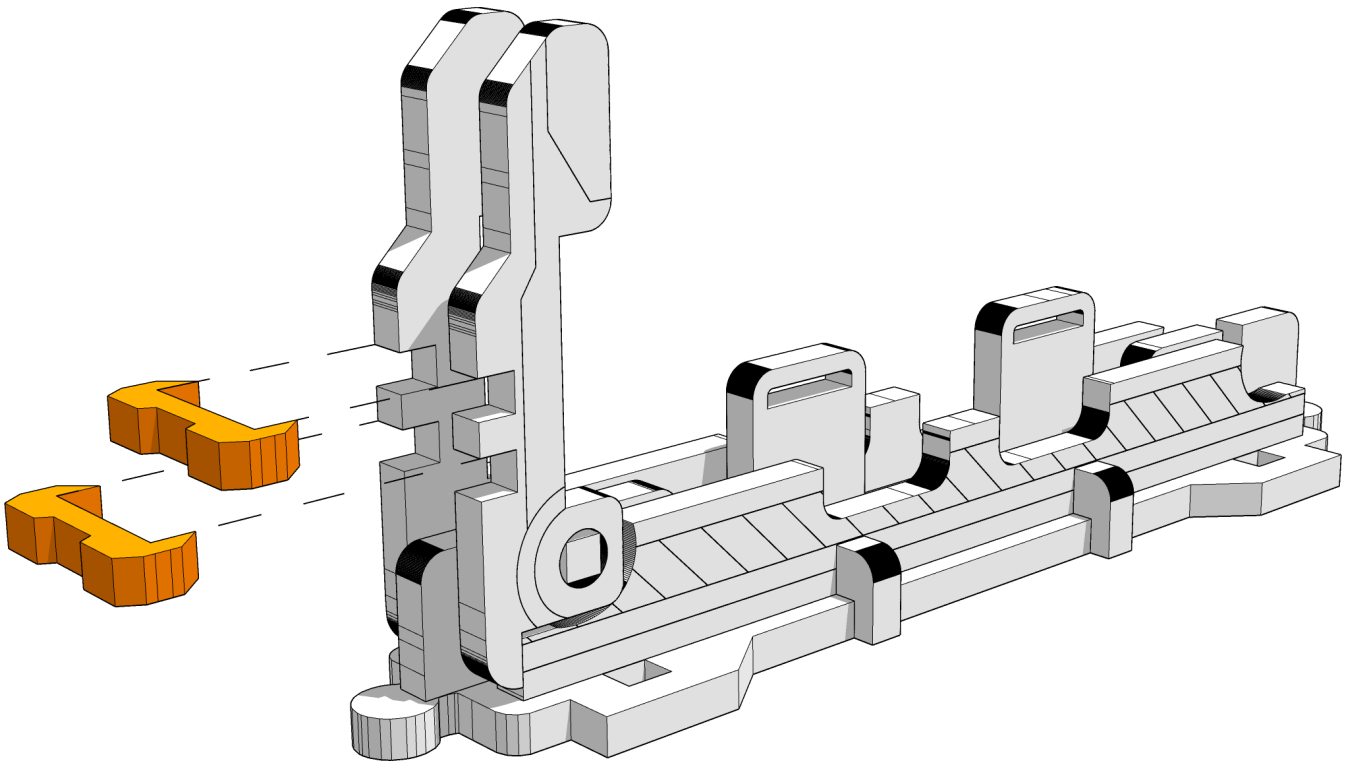



TABLETOP SCENICS

TTSCW-SFU-151
QDSC
Fences

10

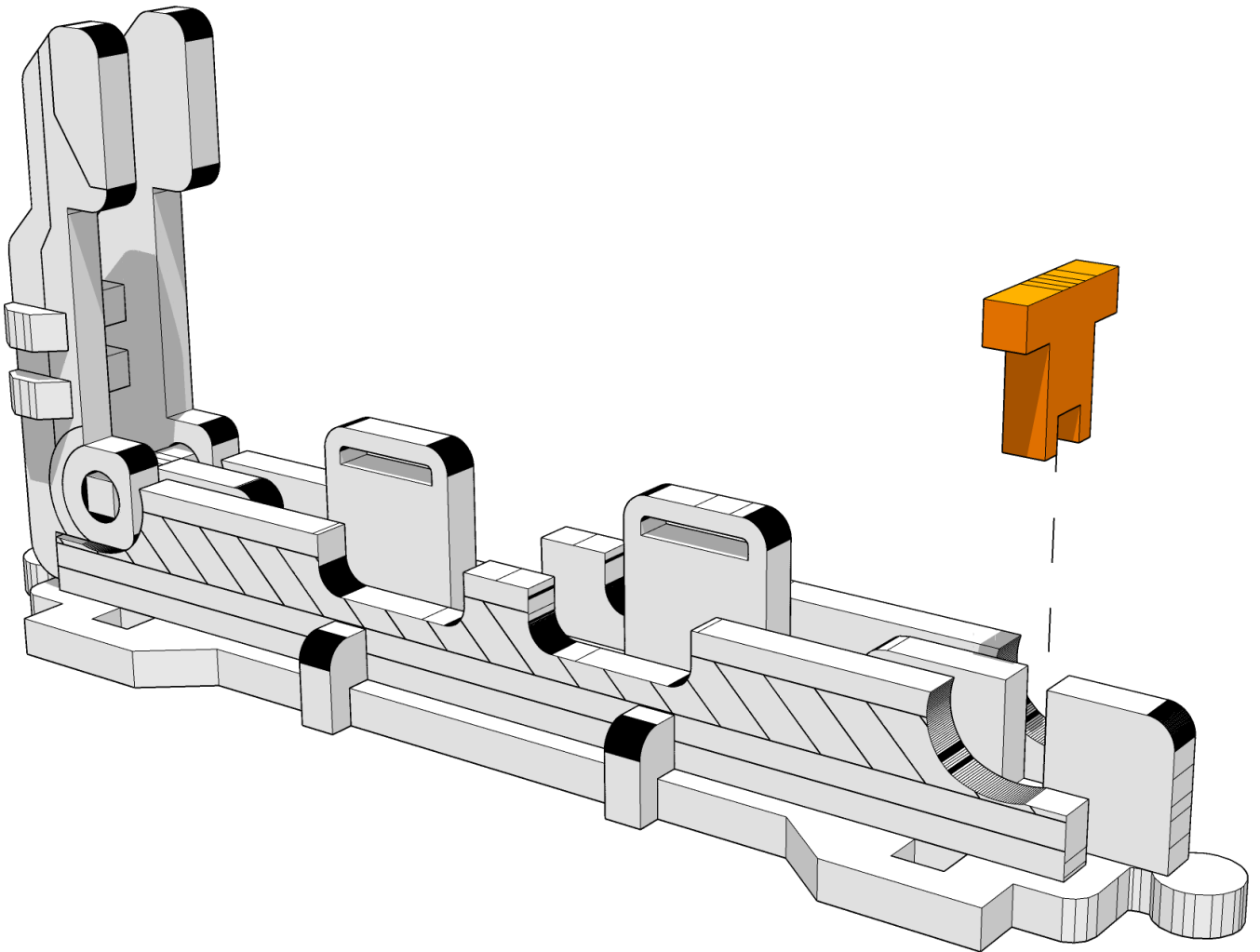



TABLETOP SCENICS

TTSCW-SFU-151
QDSC
Fences

11

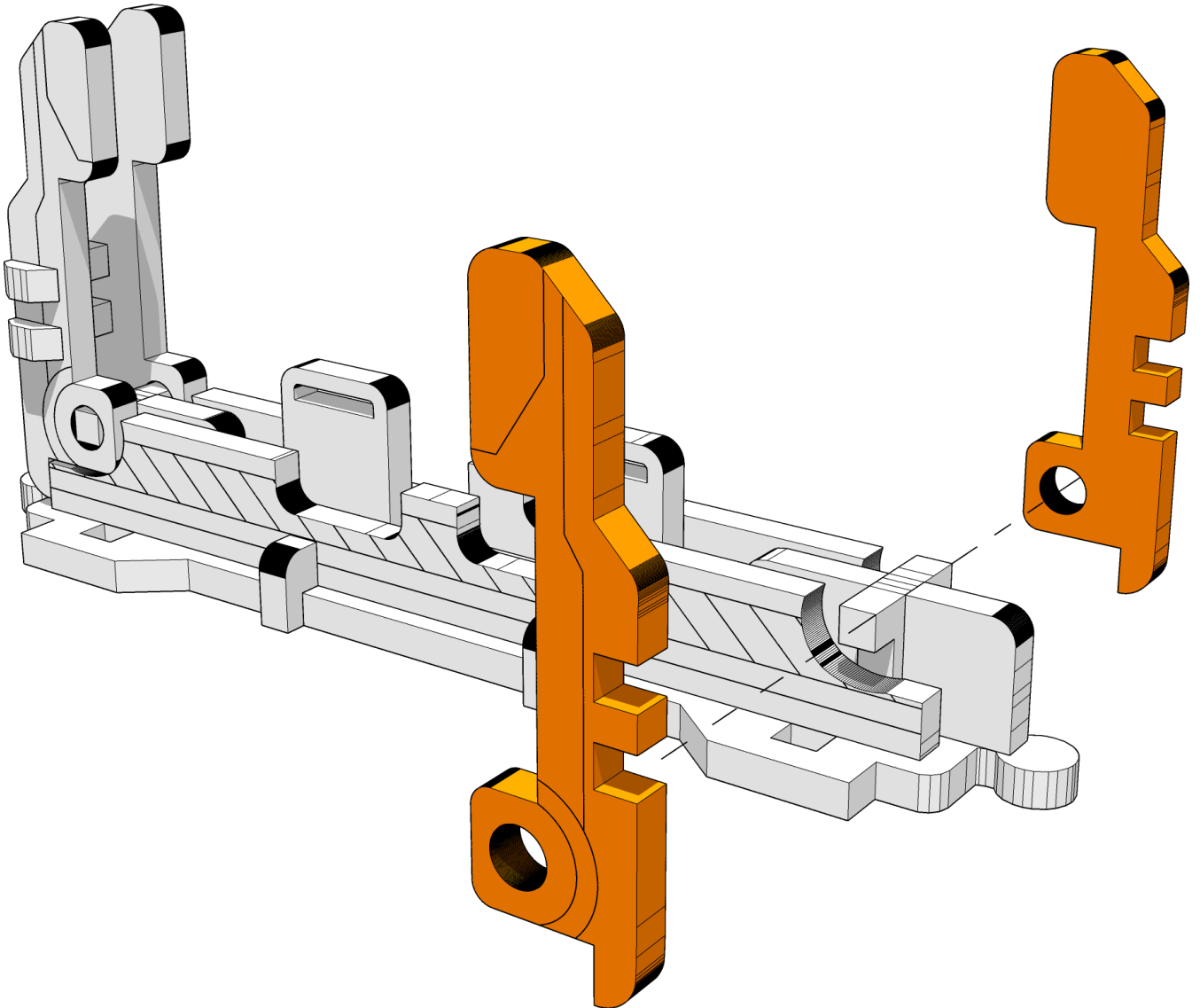

Place into position only





TABLETOP SCENICS

TTSCW-SFU-151
QDSC
Fences

12

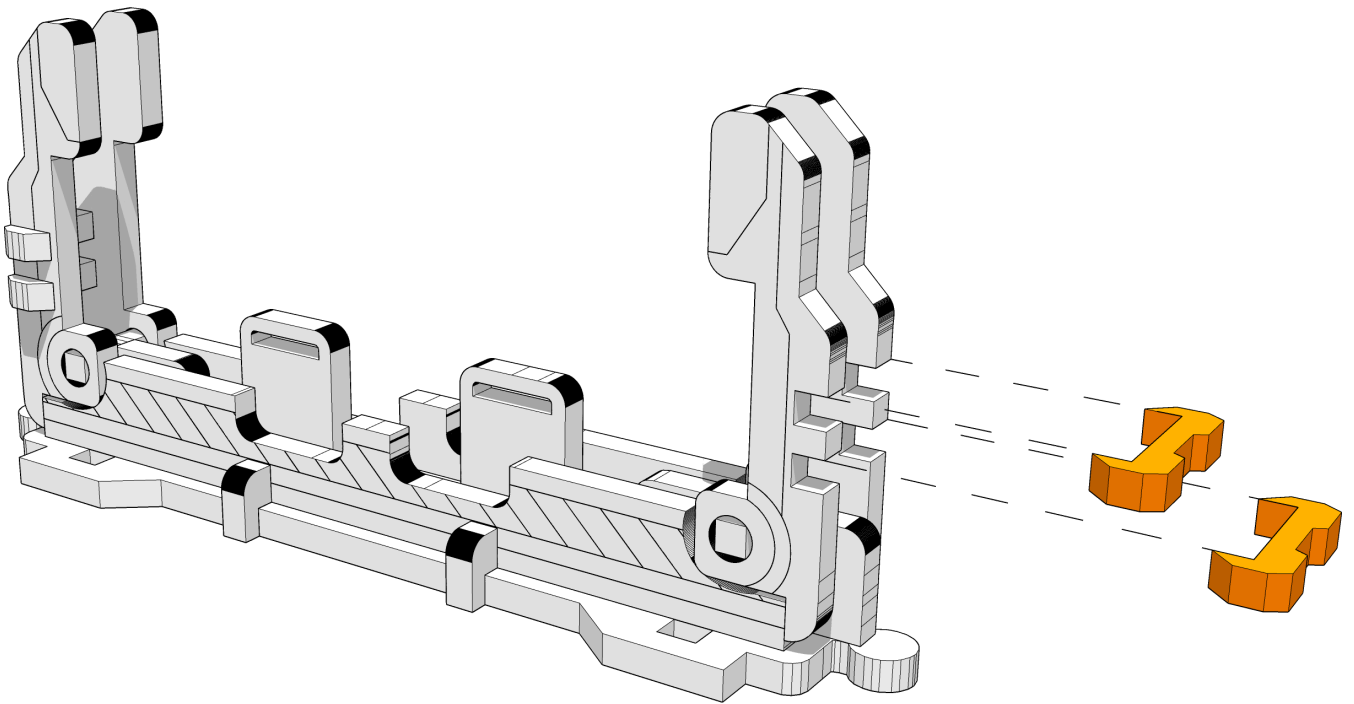



TABLETOP SCENICS

TTSCW-SFU-151
QDSC
Fences

13

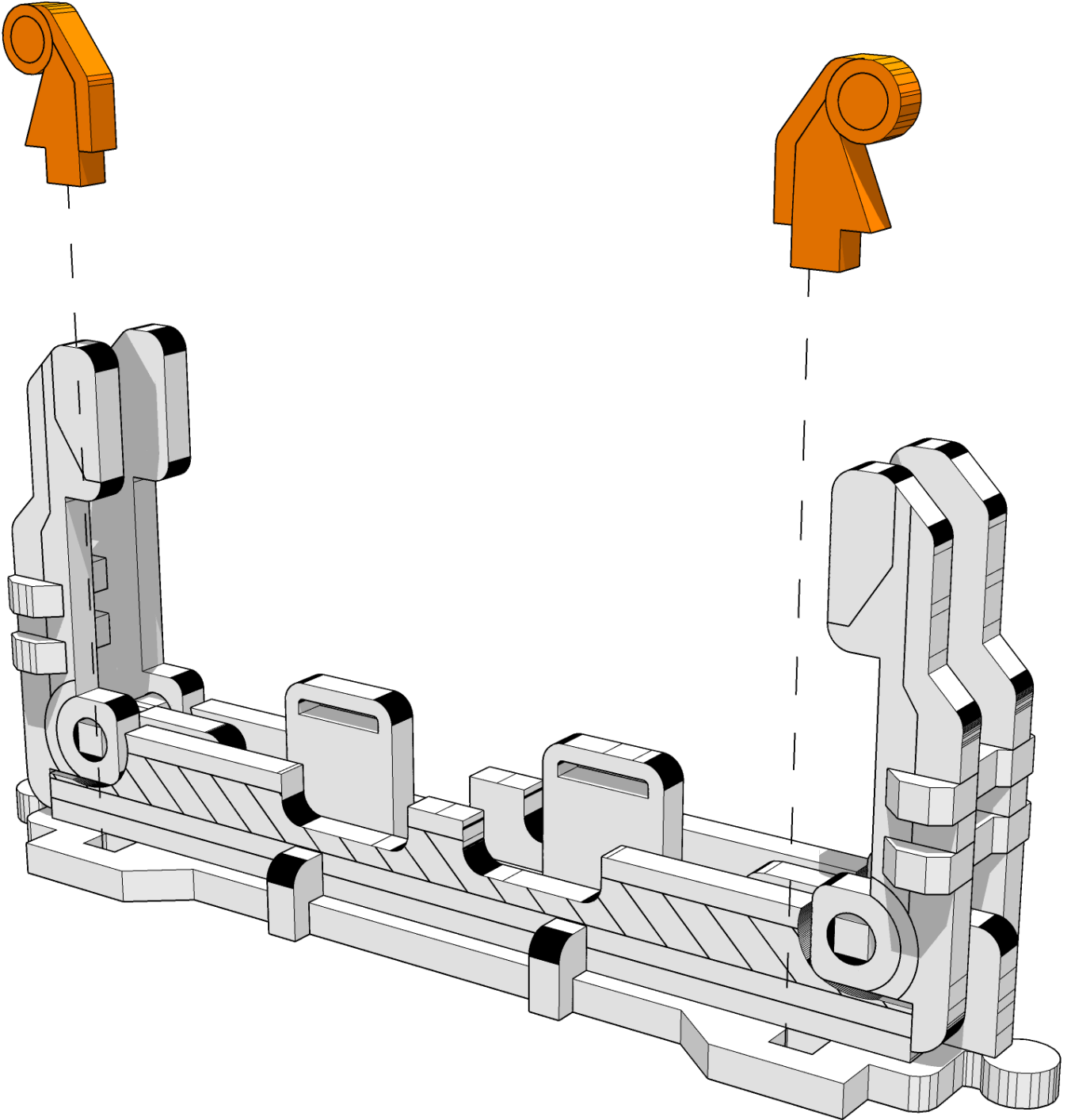

Do not get glue into the circular hinge





14

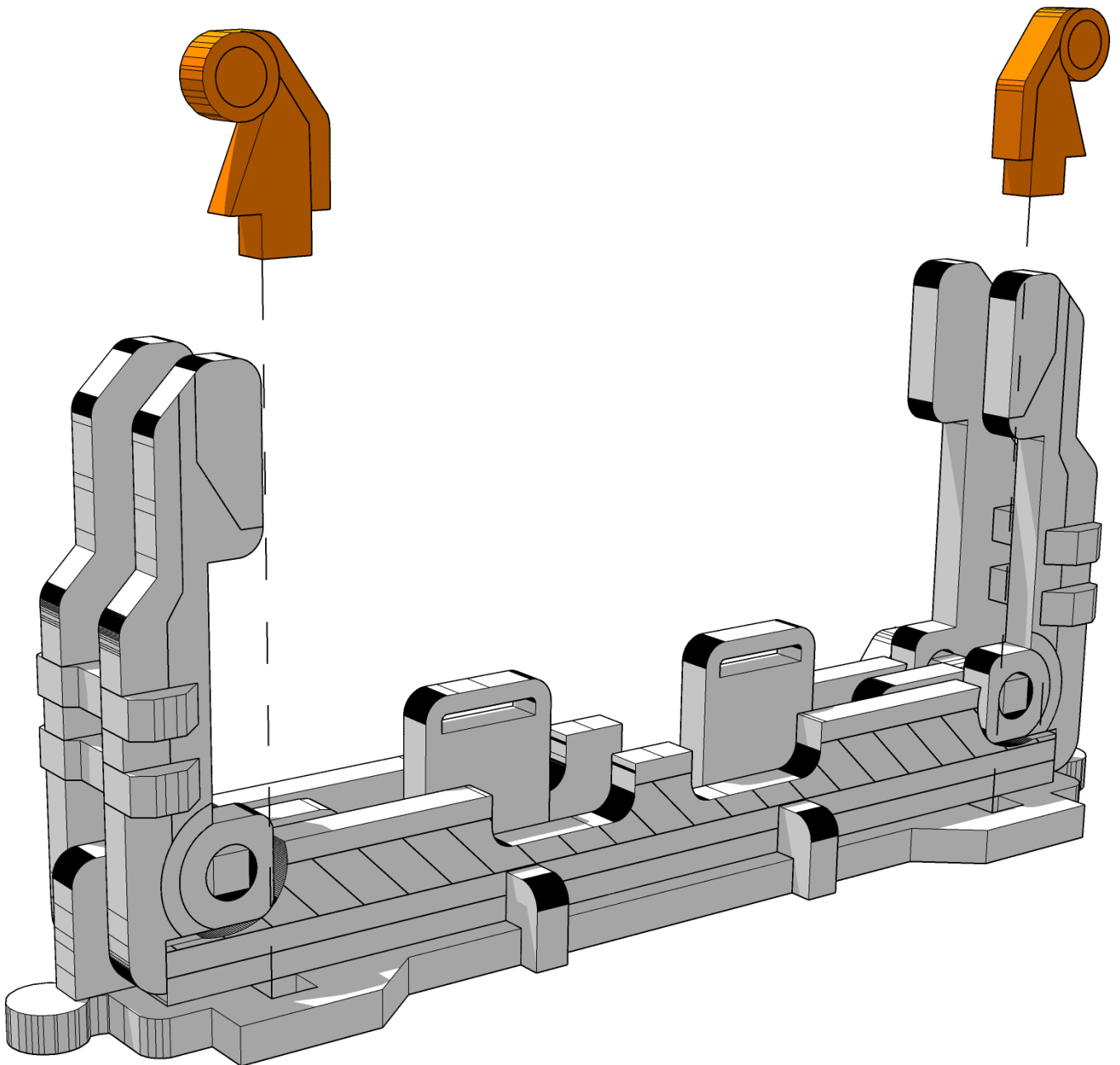

Do not get glue into the circular hinge



TABLETOP SCENICS

TTSCW-SFU-151
QDSC
Fences

15

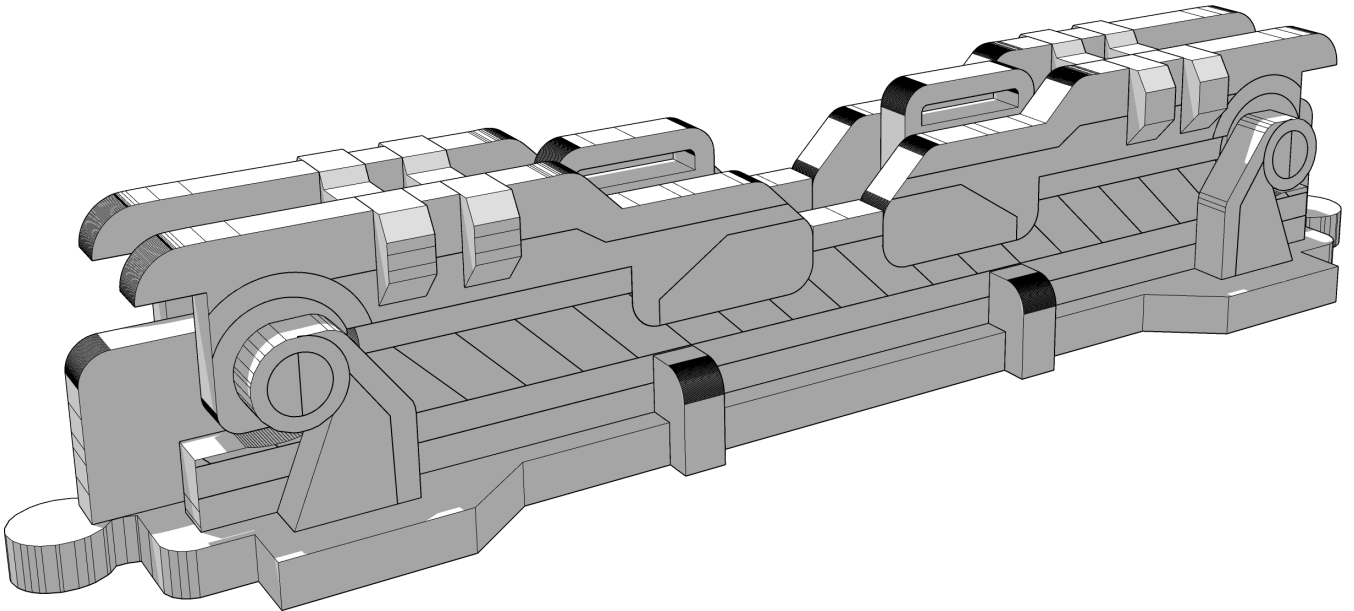

Panel can be used in this closed position or add the taller fencing section



 **TTCOMBAT**



TABLETOP SCENICS

TTSCW-SFU-151
QDSC
Fences

16

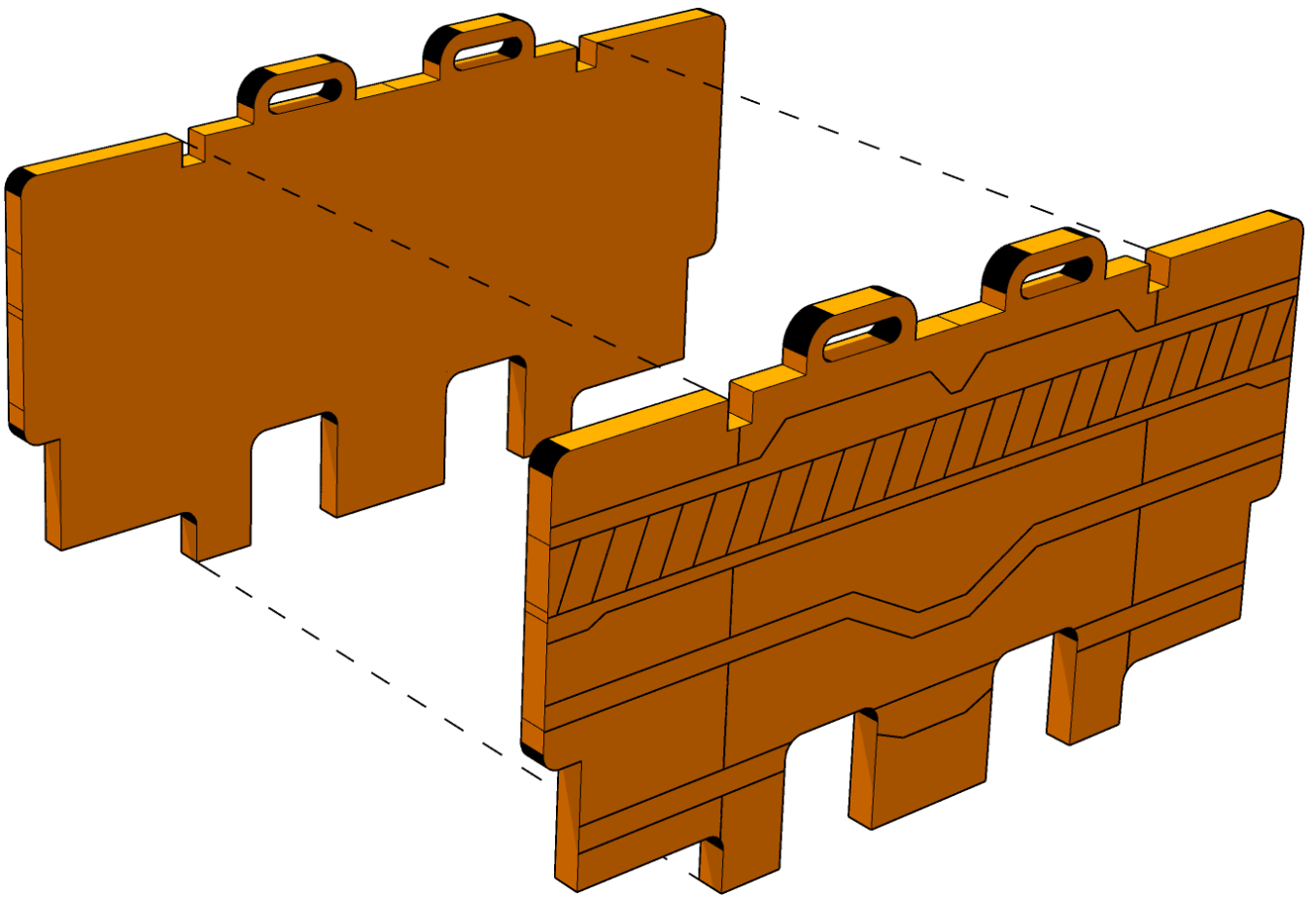



17

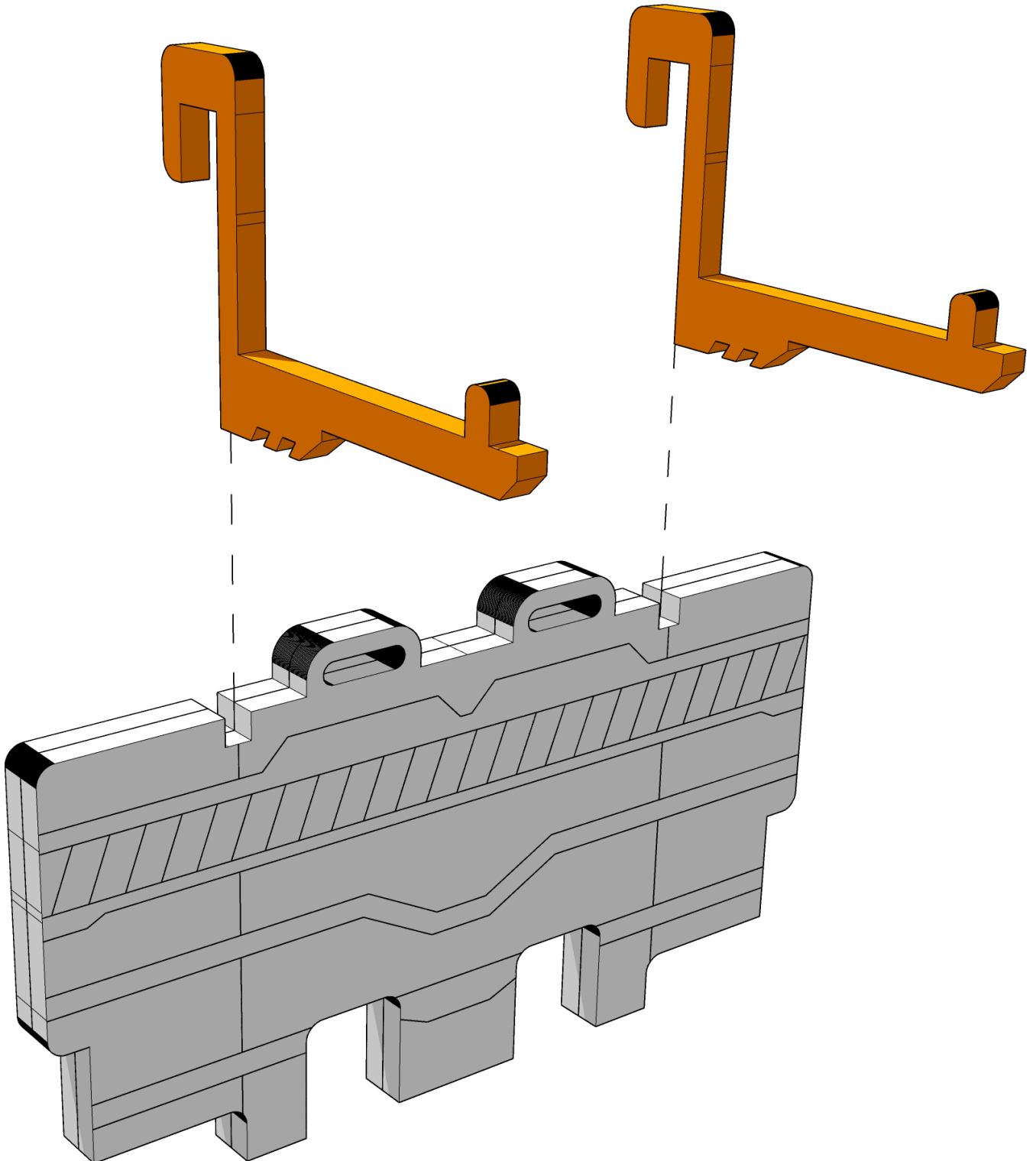

If you dont want walkways, see step 20



18

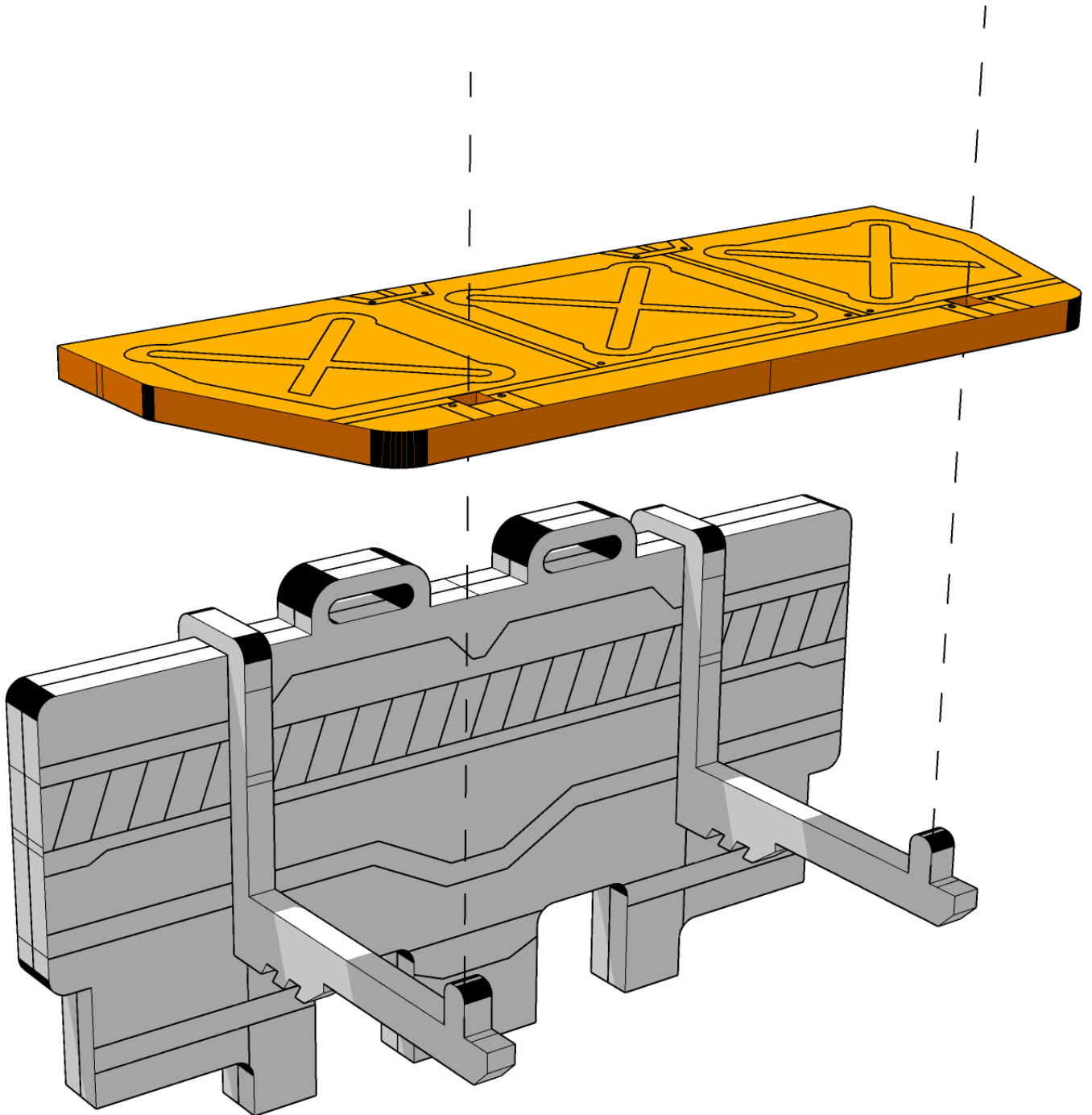



TABLETOP SCENICS

TTSCW-SFU-151
QDSC
Fences

19

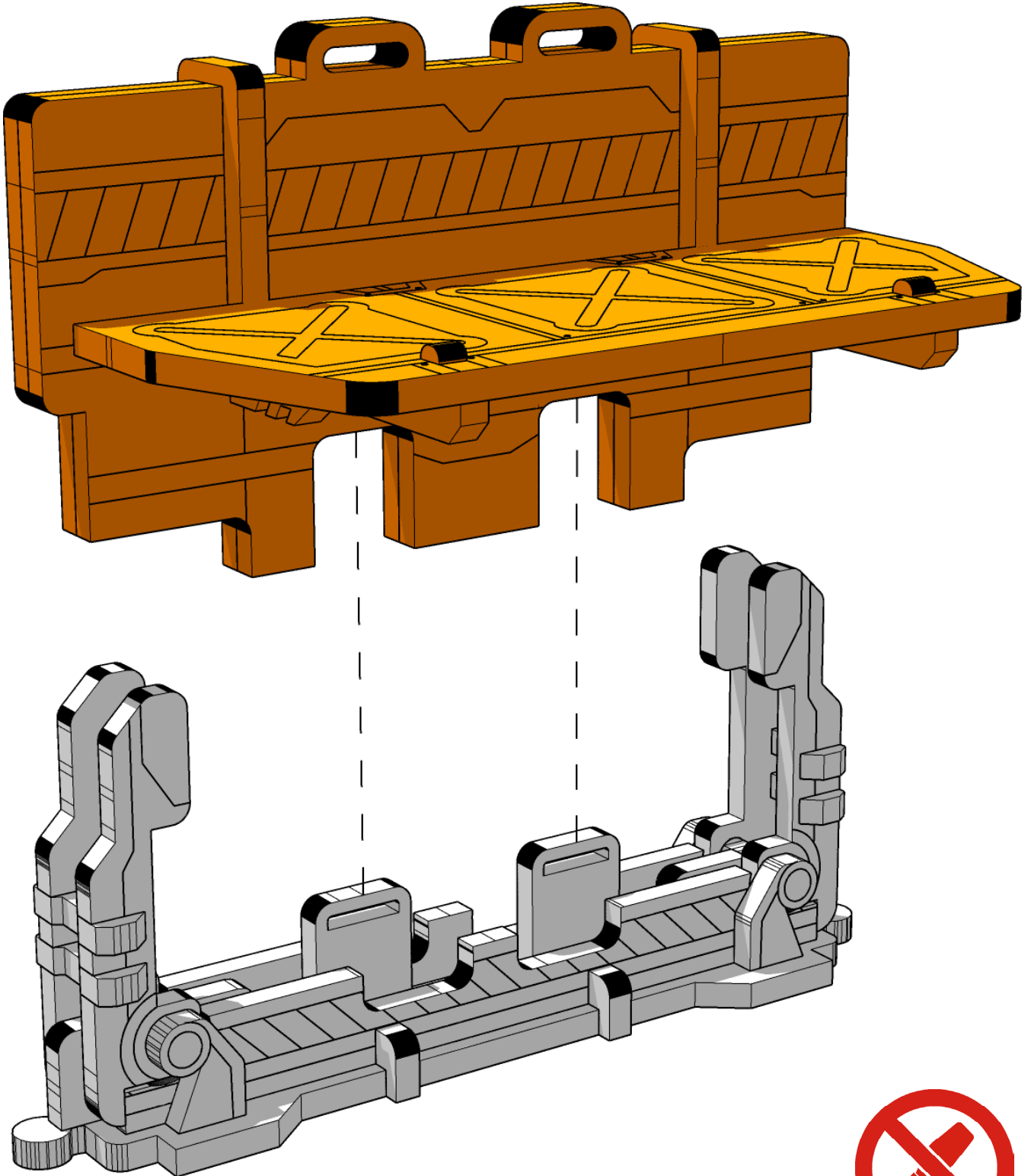

Fence Panel slots into the stand



 **TTCOMBAT**



TABLETOP SCENICS

TTSCW-SFU-151
QDSC
Fences

20

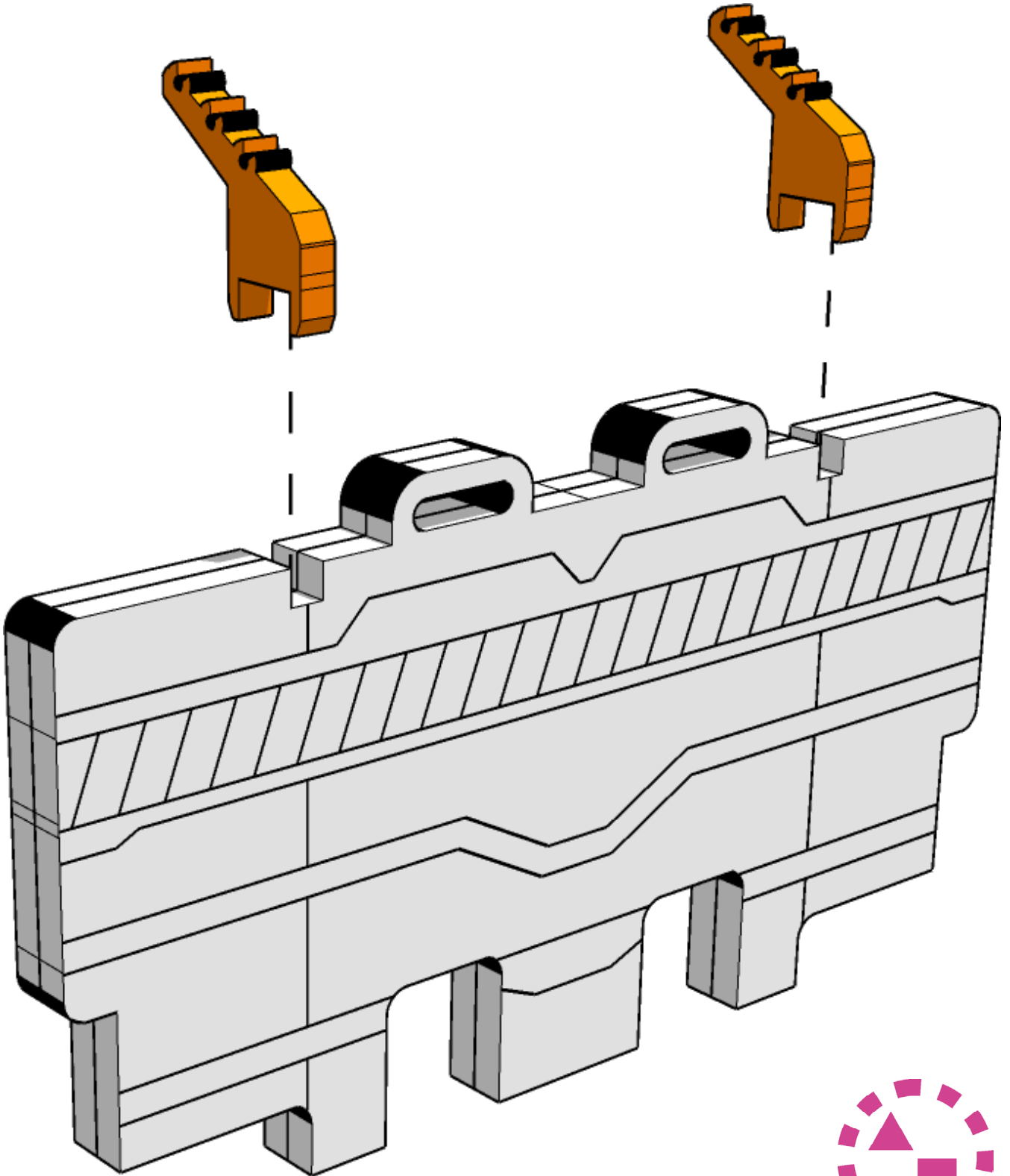

highlighted part can be used insted of the walkways



 **TTCOMBAT**



TABLETOP SCENICS

TTSCW-SFU-151
QDSC
Fences

21

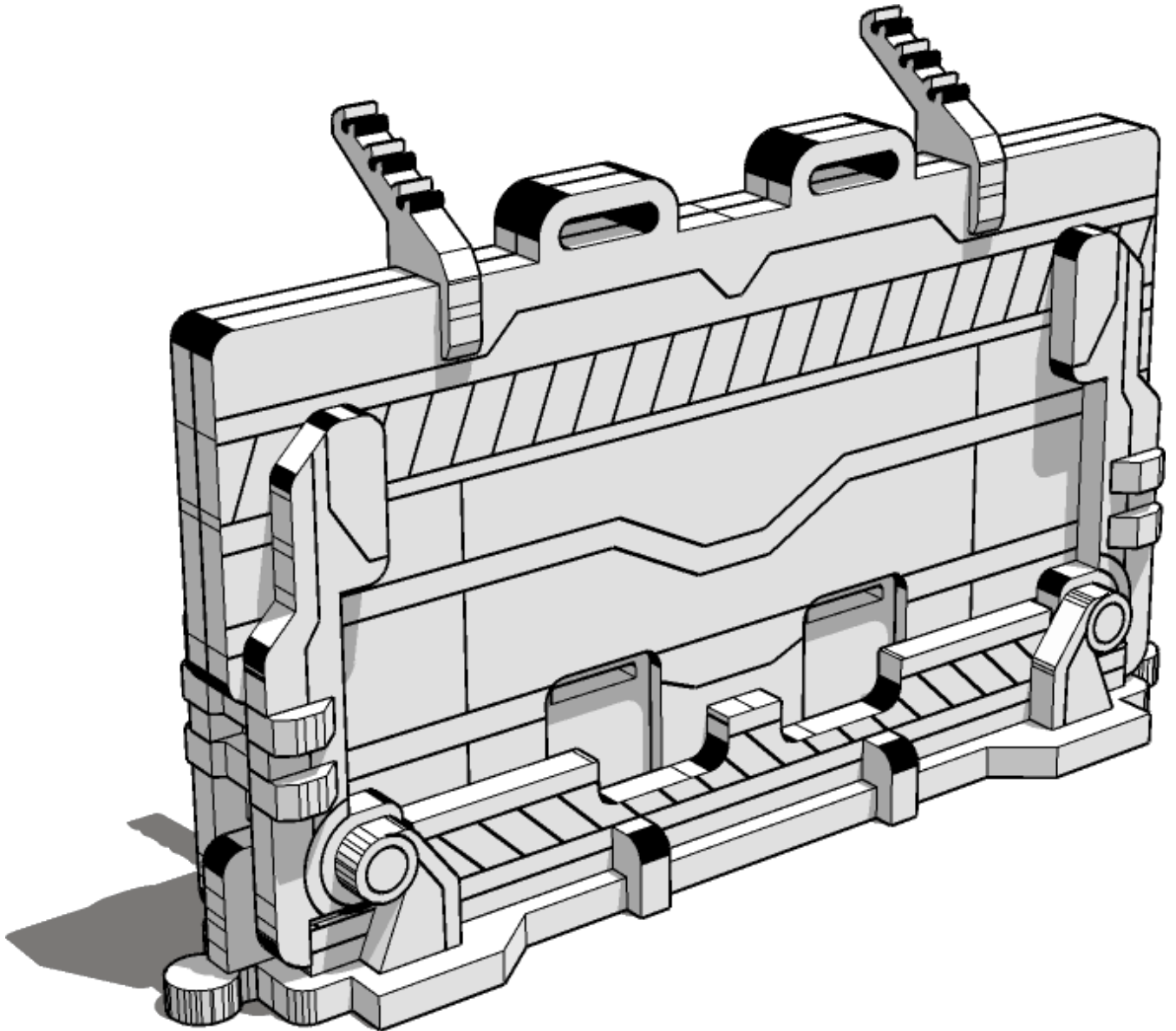

 TTCOMBAT



TABLETOP SCENICS

TTSCW-SFU-151
QDSC
Fences

22

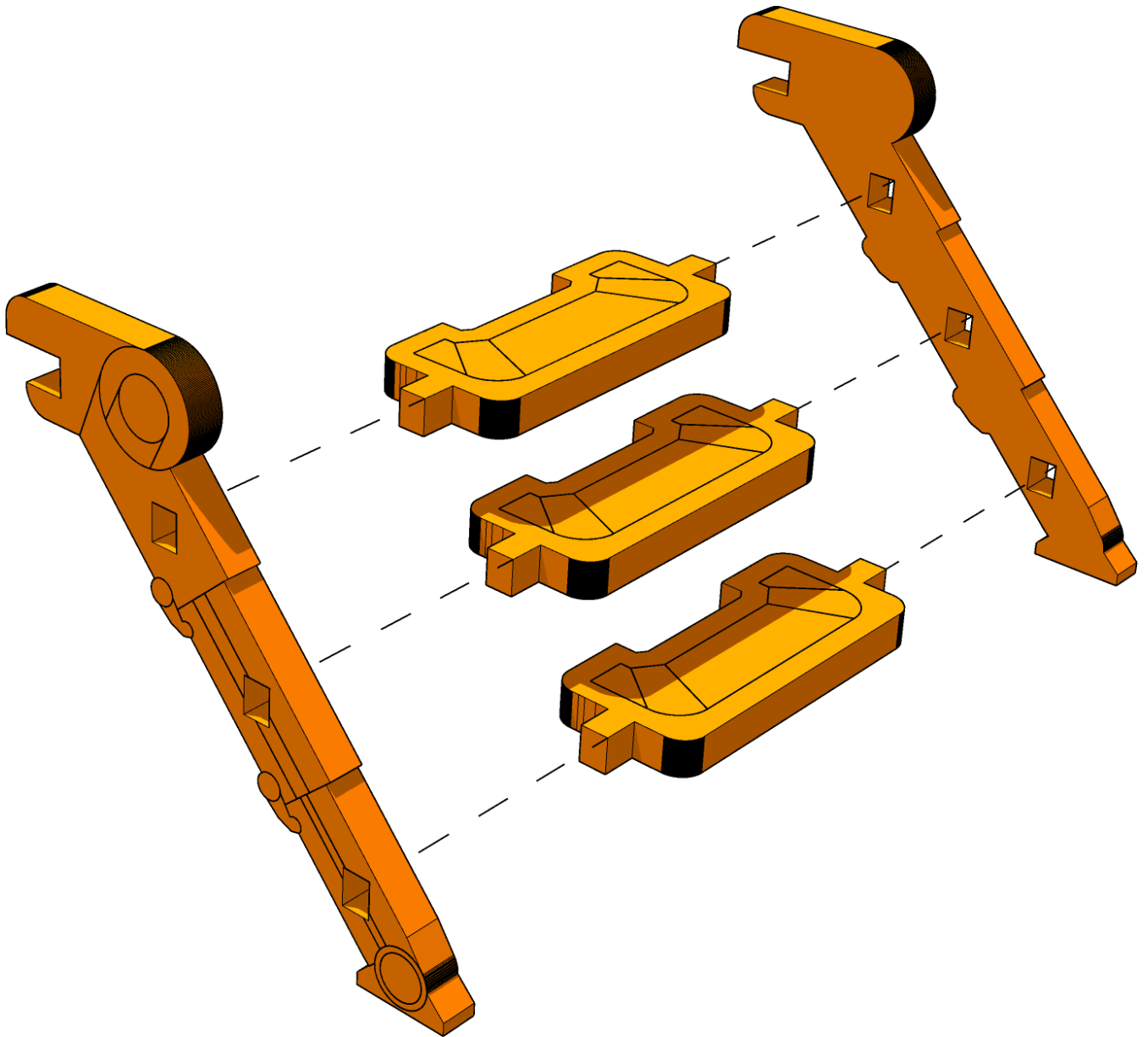



TABLETOP SCENICS

TTSCW-SFU-151
QDSC
Fences

23

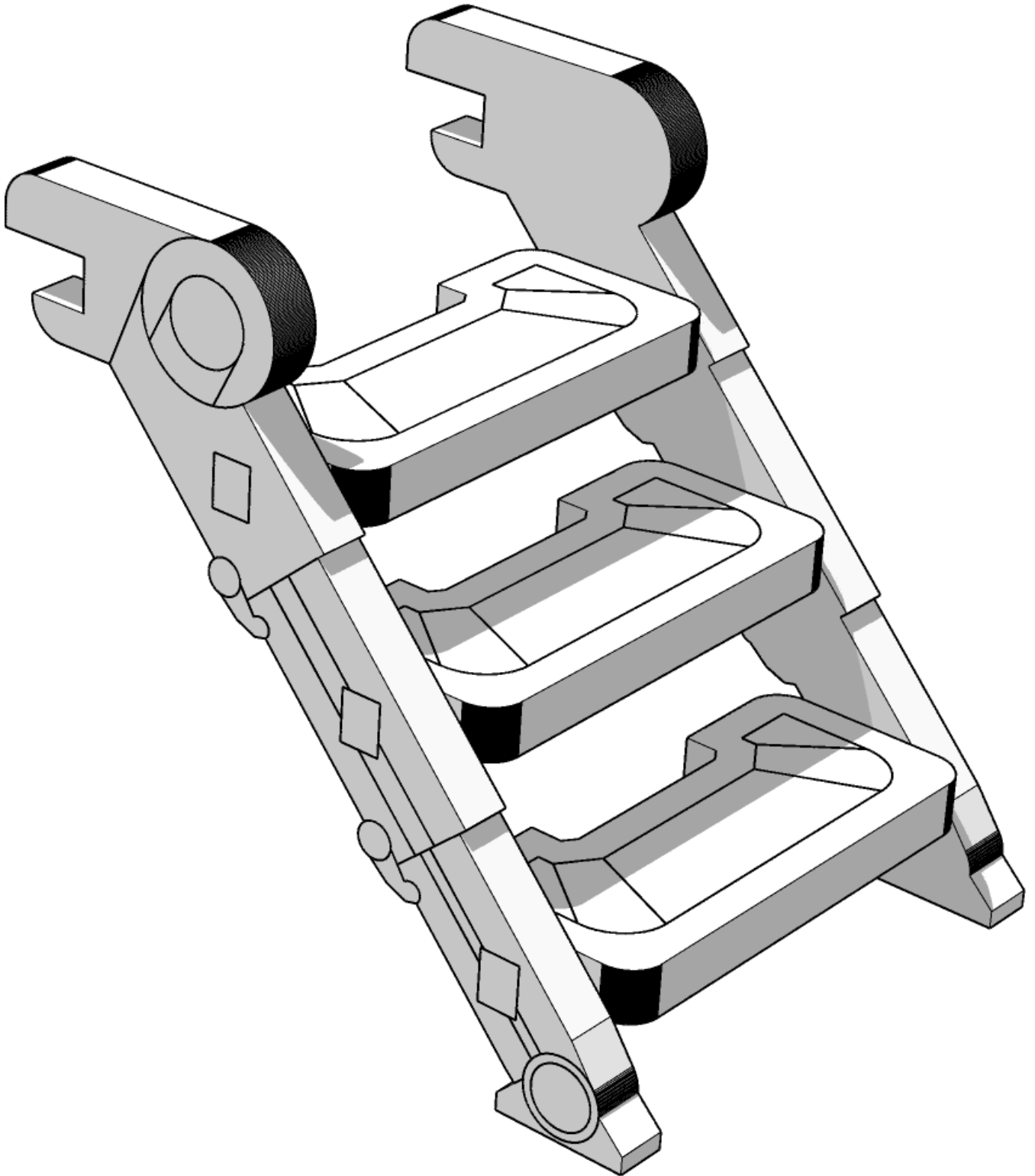



TABLETOP SCENICS

TTSCW-SFU-151
QDSC
Fences

24

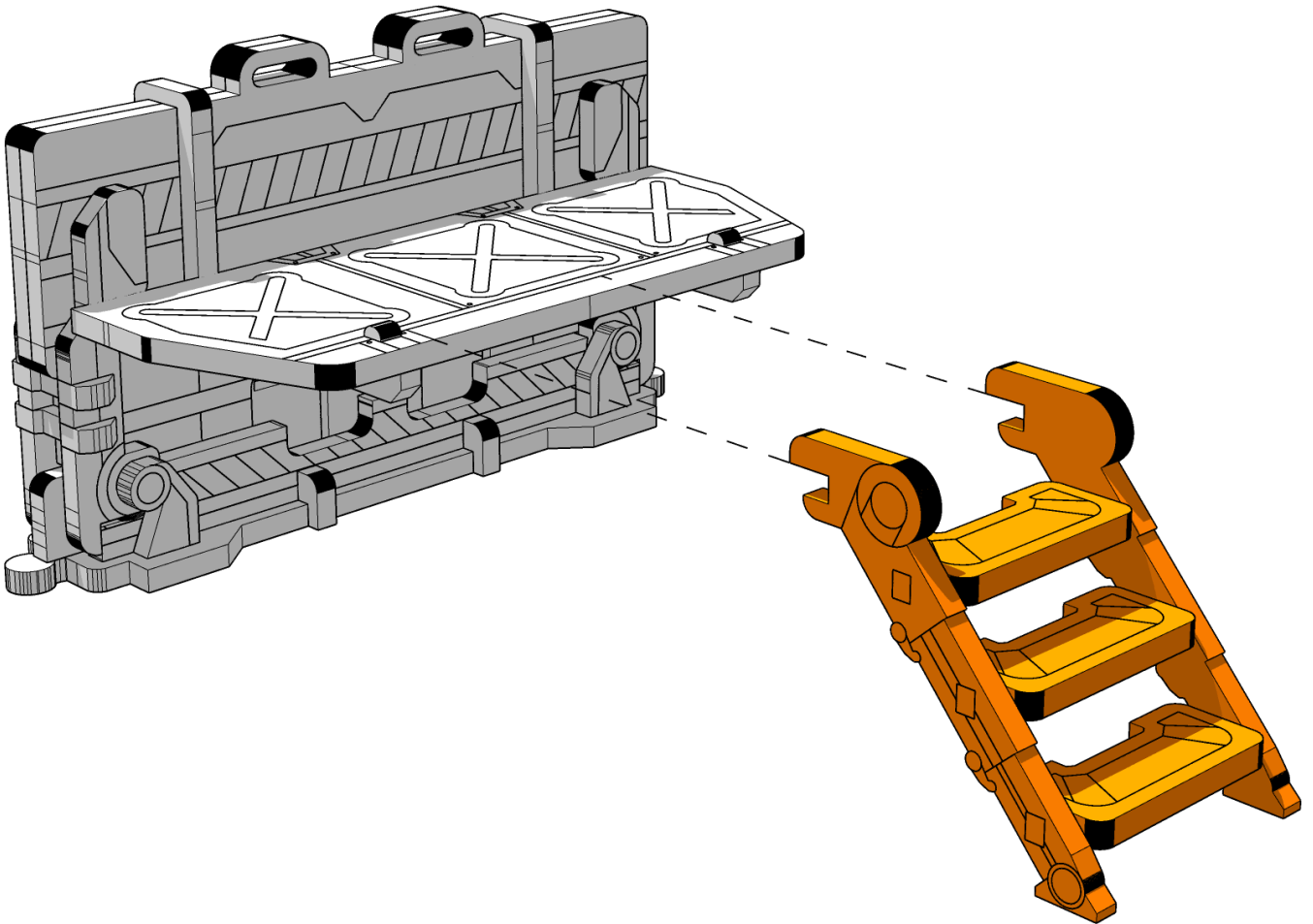

Do NOT glue to allow for alternative
layouts





TABLETOP SCENICS

TTSCW-SFU-151
QDSC
Fences

25

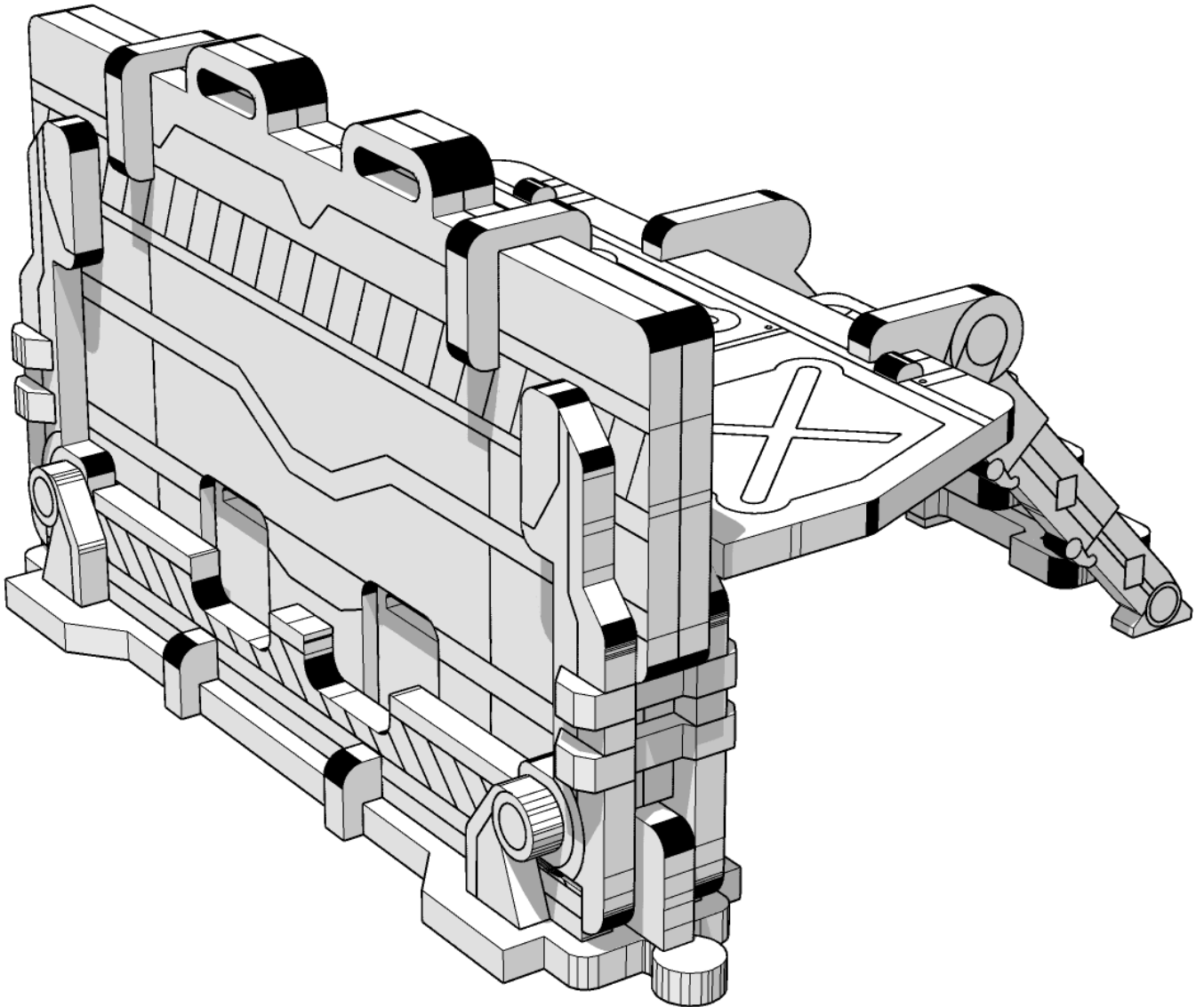

 TTCOMBAT



TABLETOP SCENICS

TTSCW-SFU-151
QDSC
Fences

26

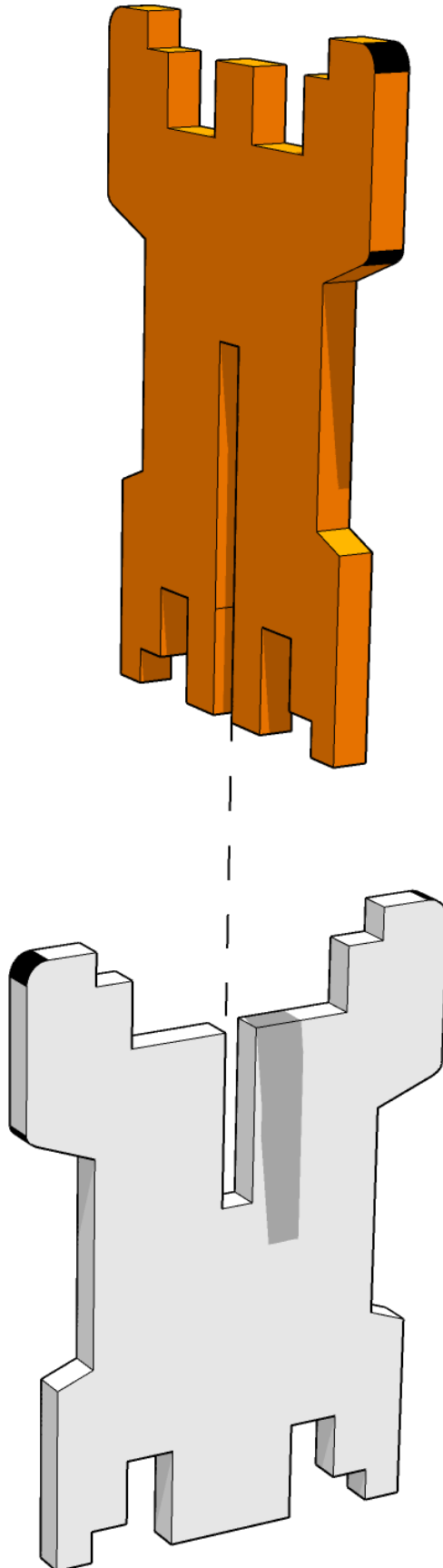



TABLETOP SCENICS

TTSCW-SFU-151
QDSC
Fences

27

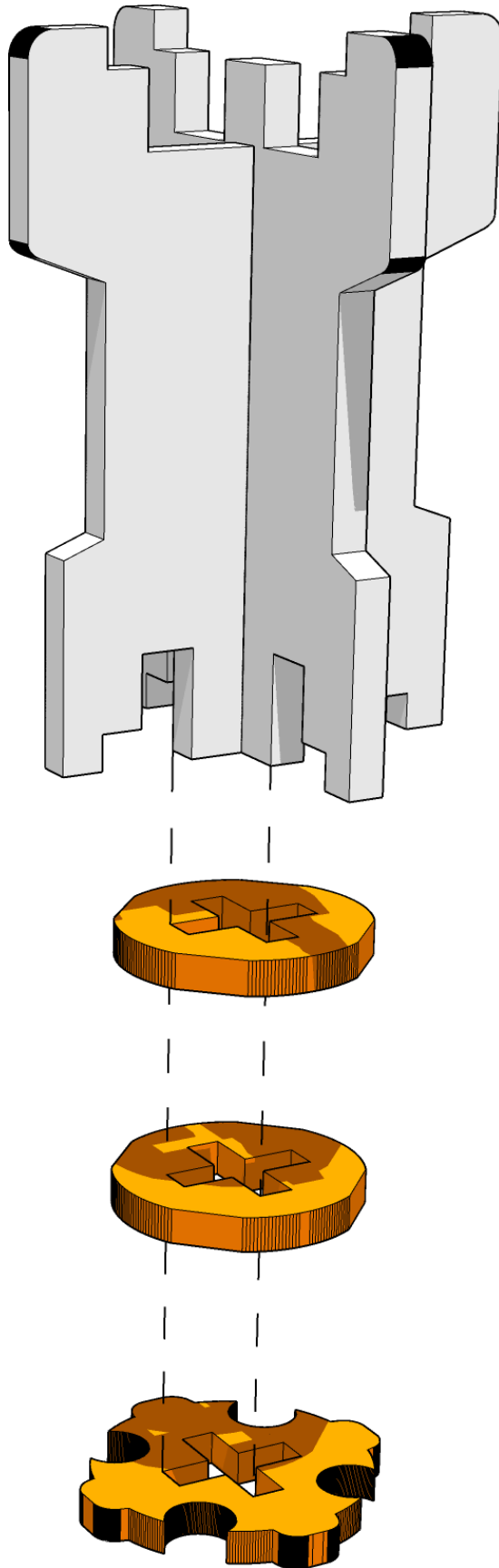



TABLETOP SCENICS

TTSCW-SFU-151
QDSC
Fences

28

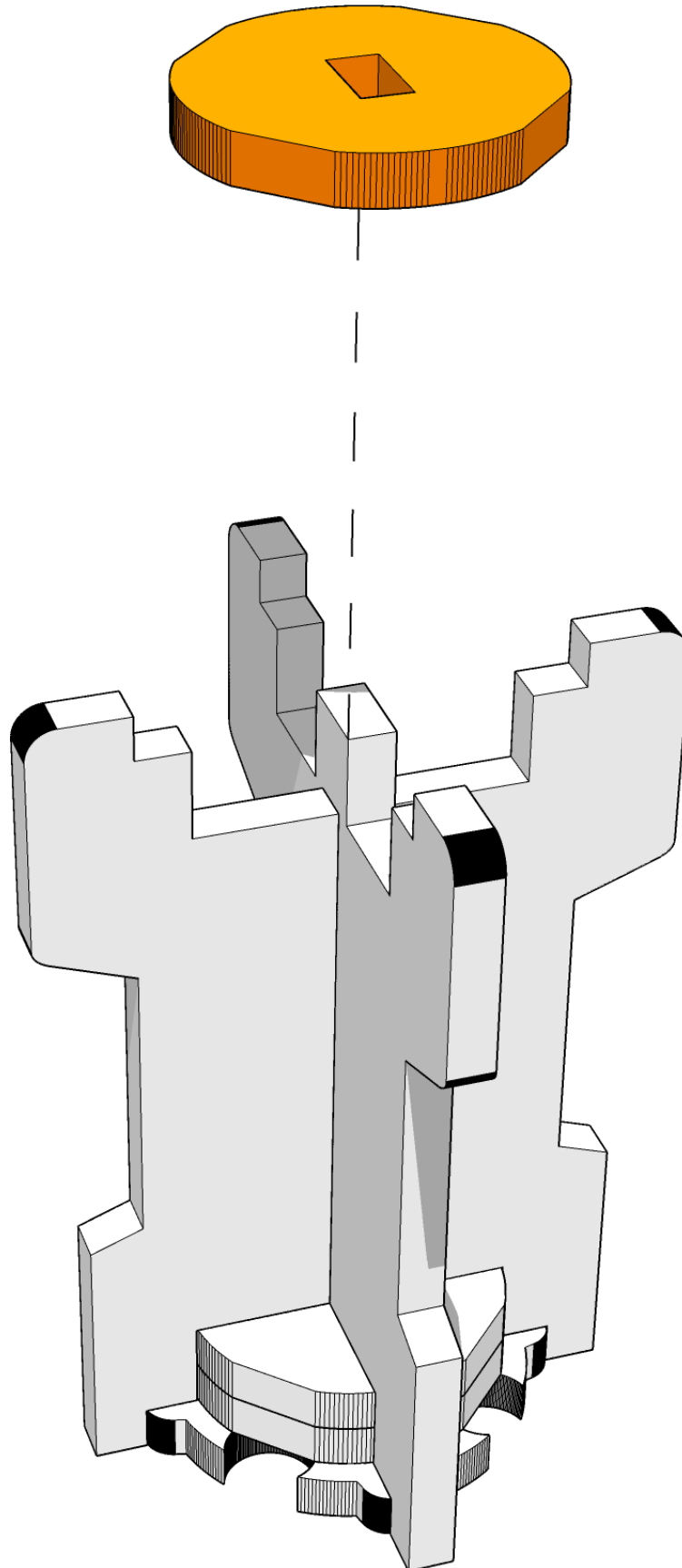



TABLETOP SCENICS

TTSCW-SFU-151
QDSC
Fences

29

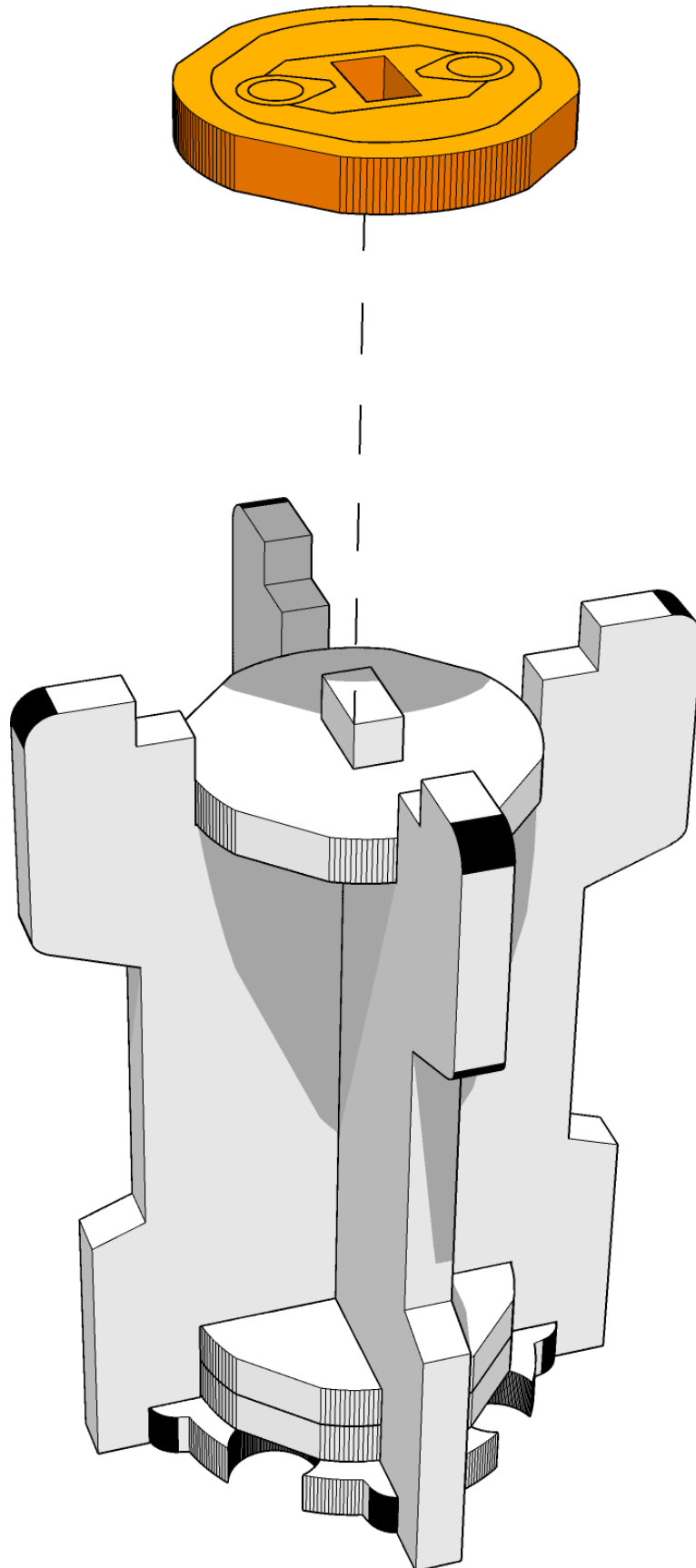



TABLETOP SCENICS

TTSCW-SFU-151
QDSC
Fences

30

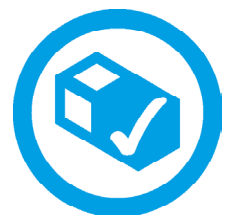
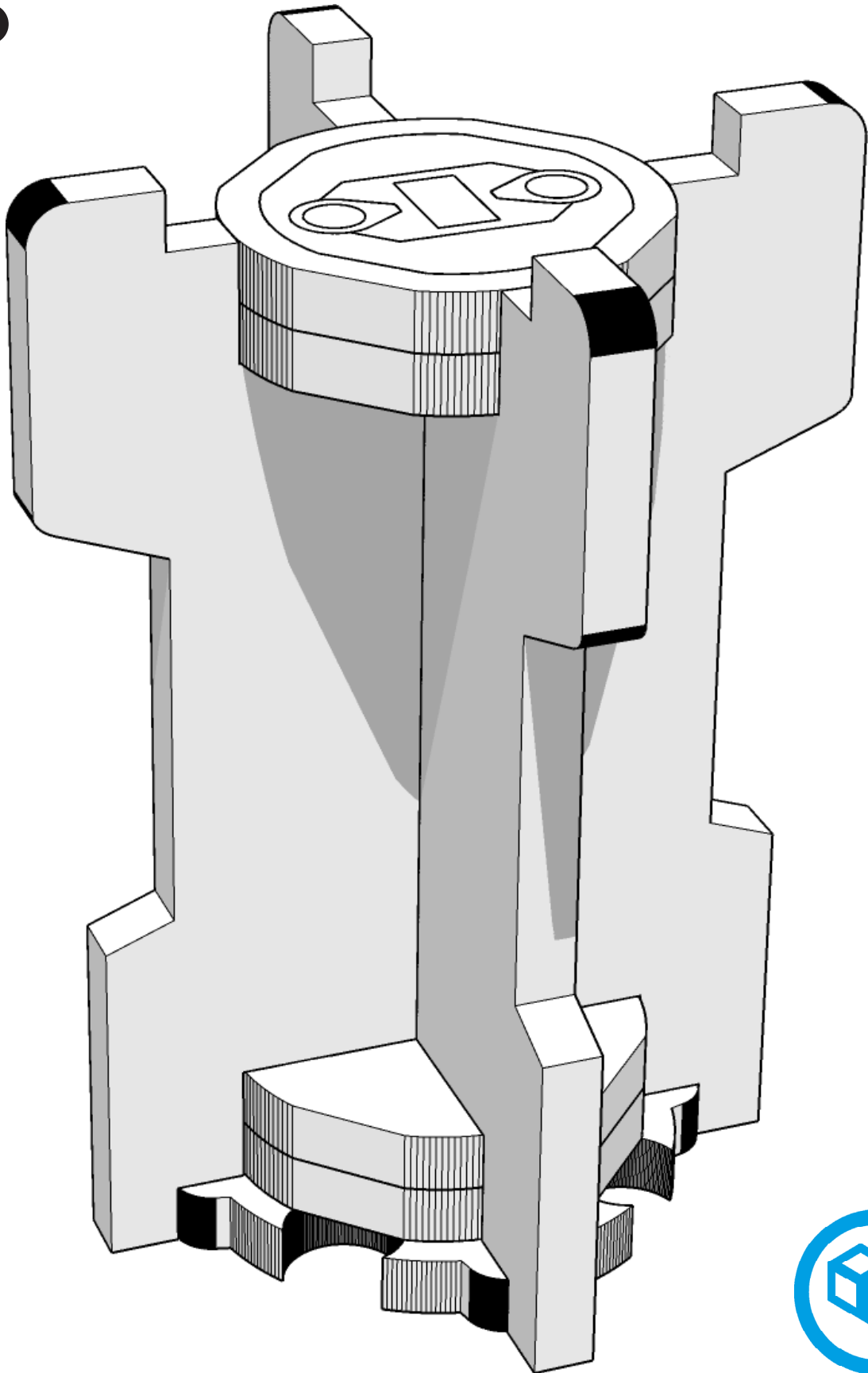

 TCOMBAT



TABLETOP SCENICS

TTSCW-SFU-151
QDSC
Fences

31

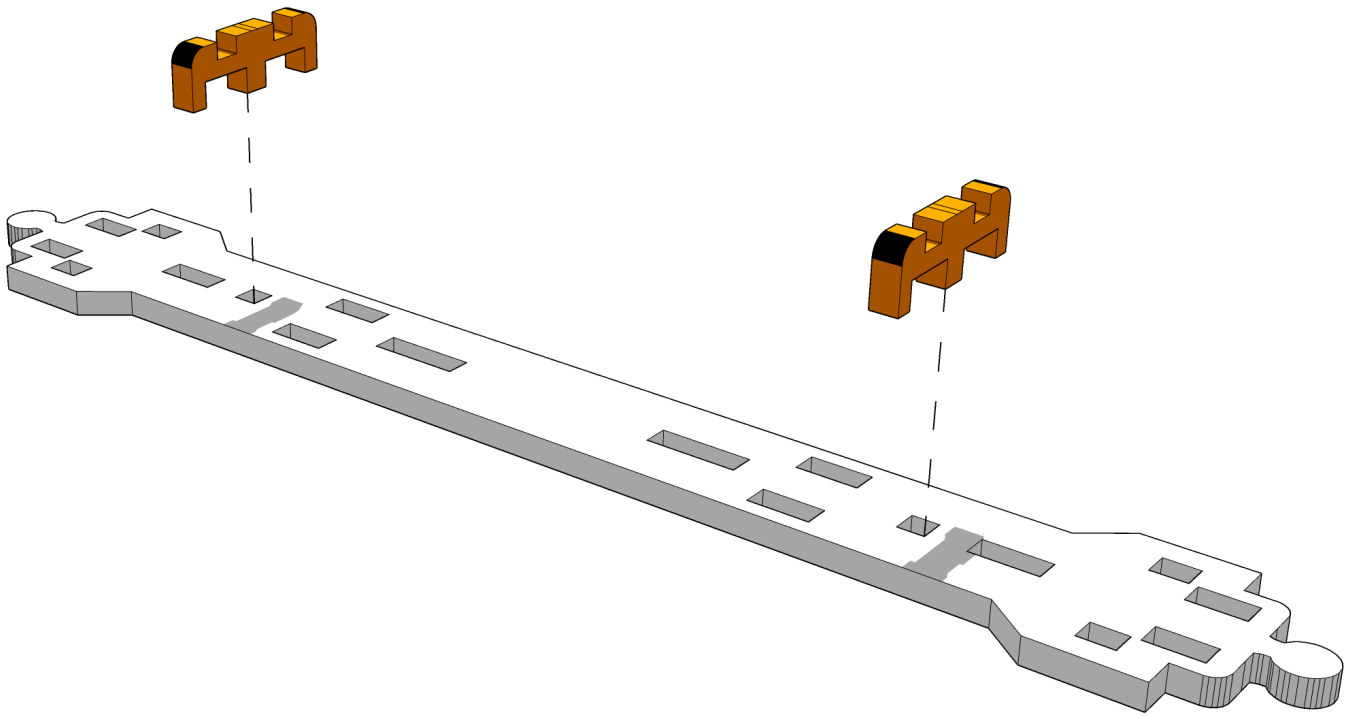



TABLETOP SCENICS

TTSCW-SFU-151
QDSC
Fences

32

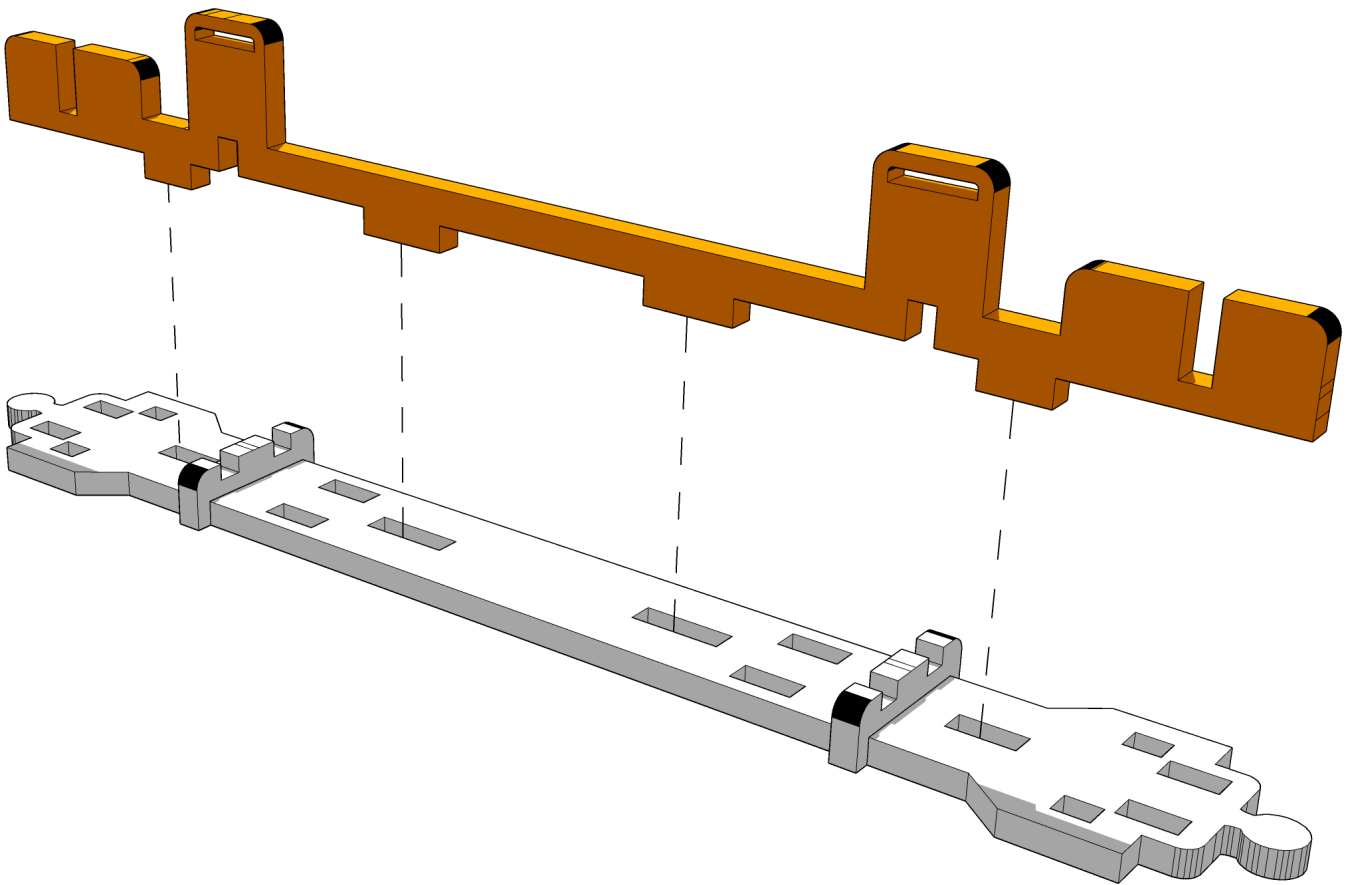



TABLETOP SCENICS

TTSCW-SFU-151
QDSC
Fences

33

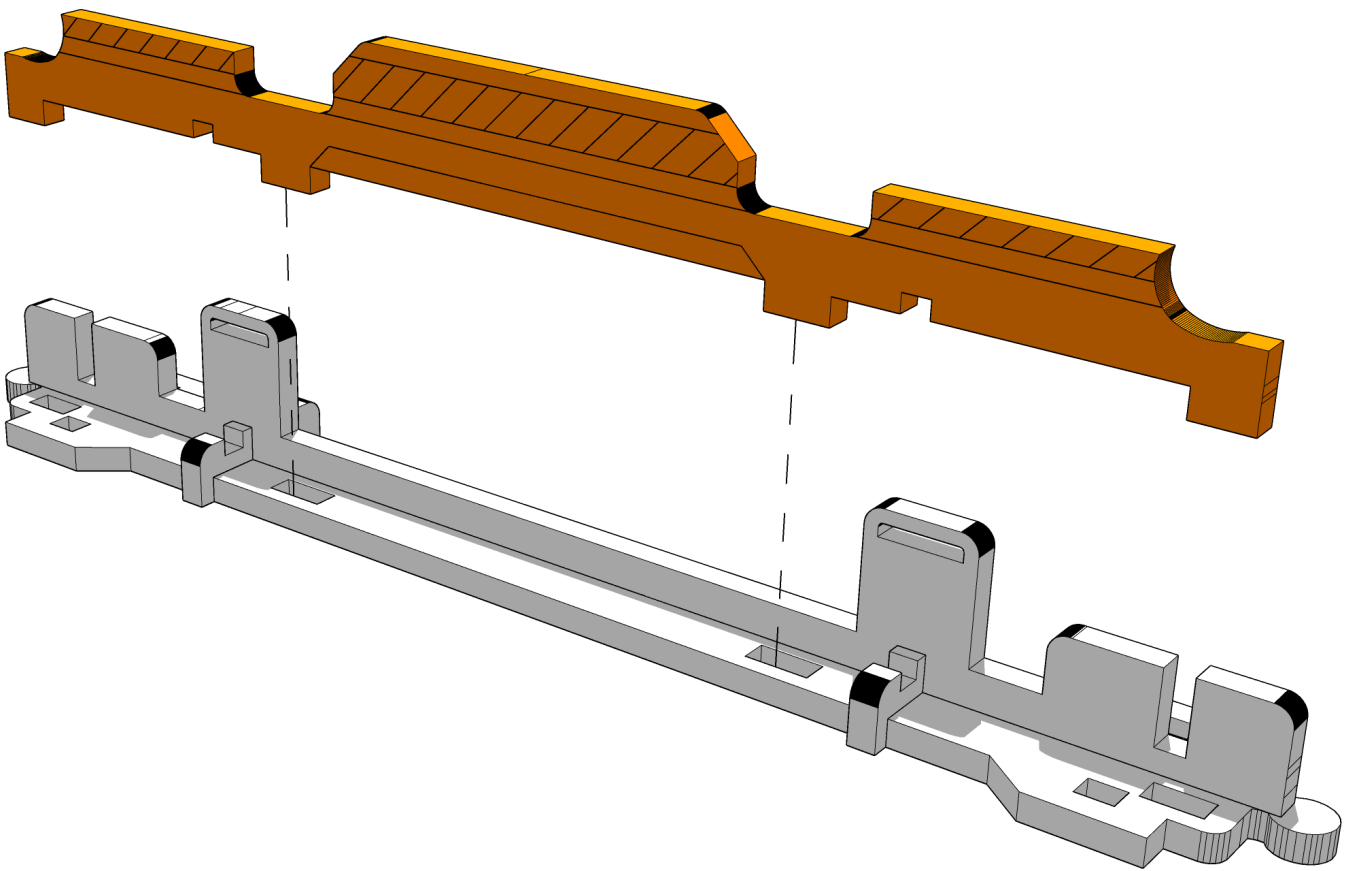



34

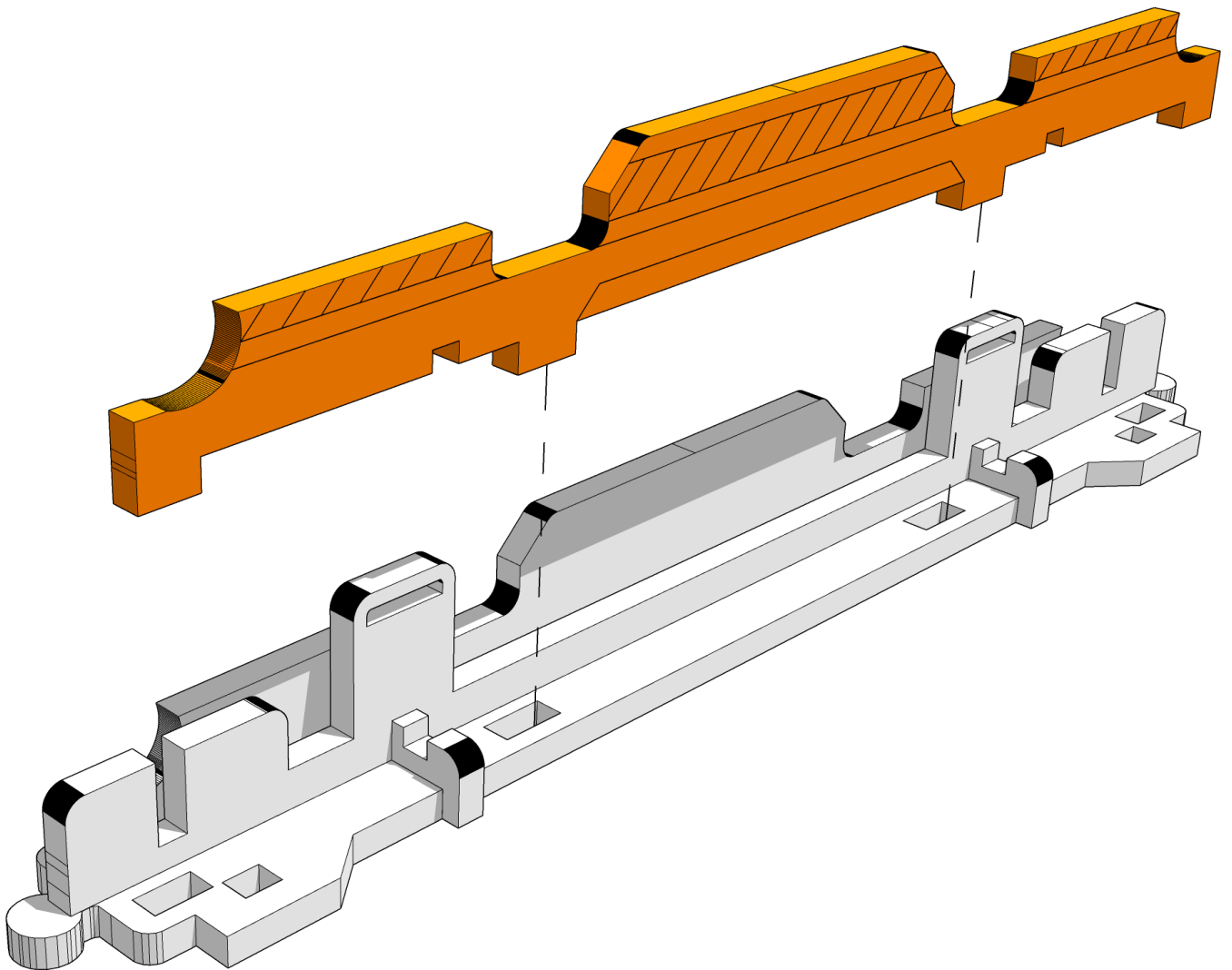



TABLETOP SCENICS

TTSCW-SFU-151
QDSC
Fences

35

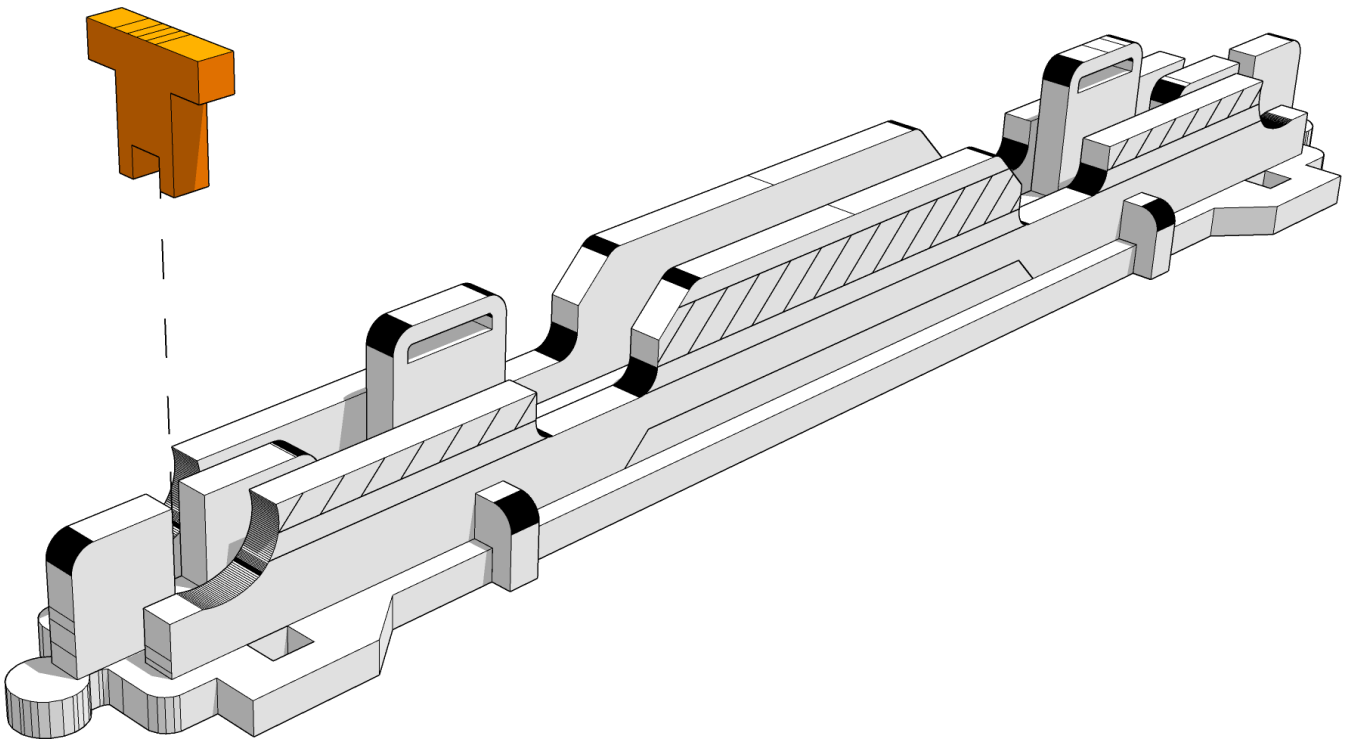



TABLETOP SCENICS

TTSCW-SFU-151
QDSC
Fences

36

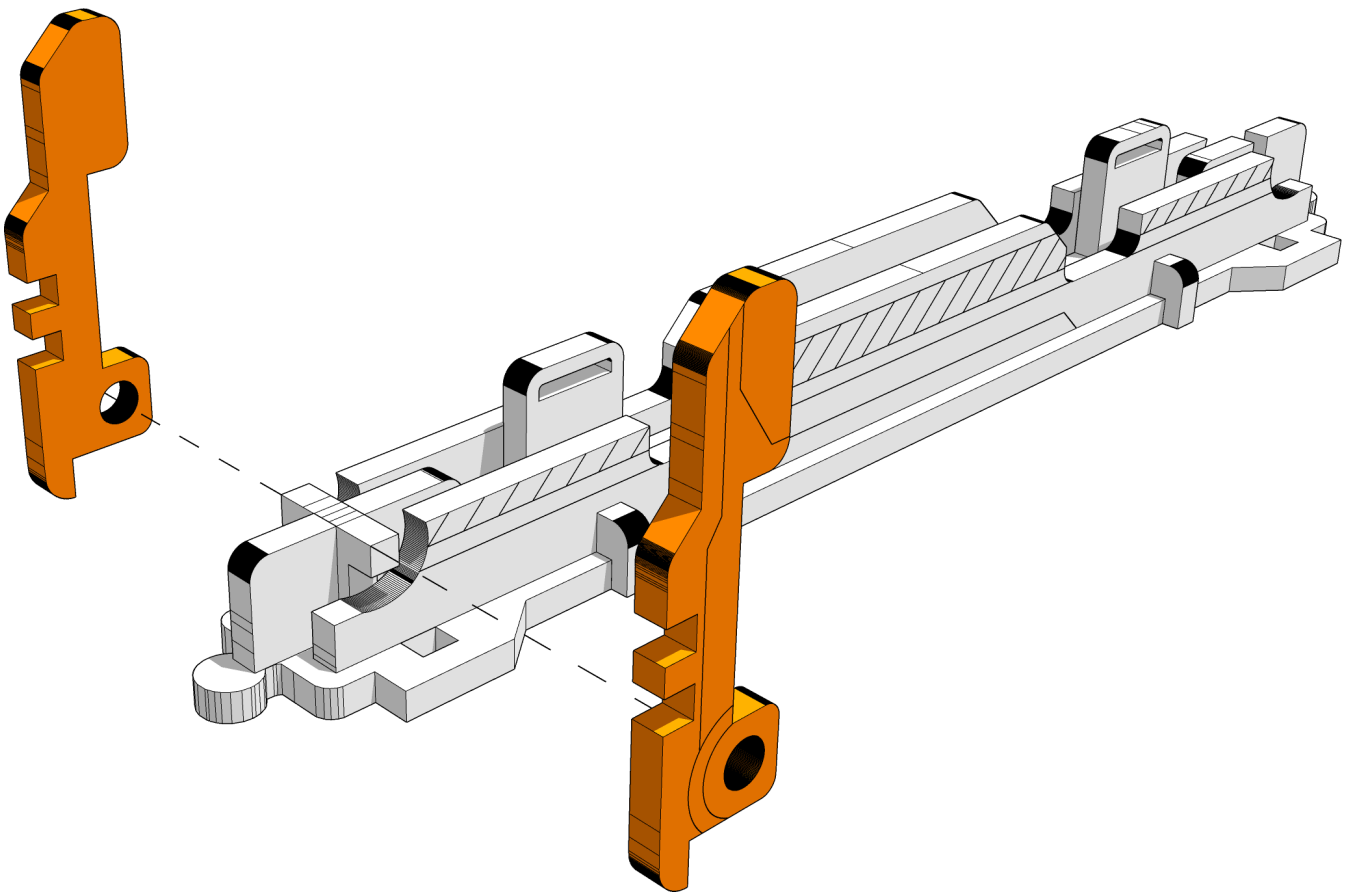

Highlighted parts are longer.
Place into position only



 **TTCOMBAT**



TABLETOP SCENICS

TTSCW-SFU-151
QDSC
Fences

37

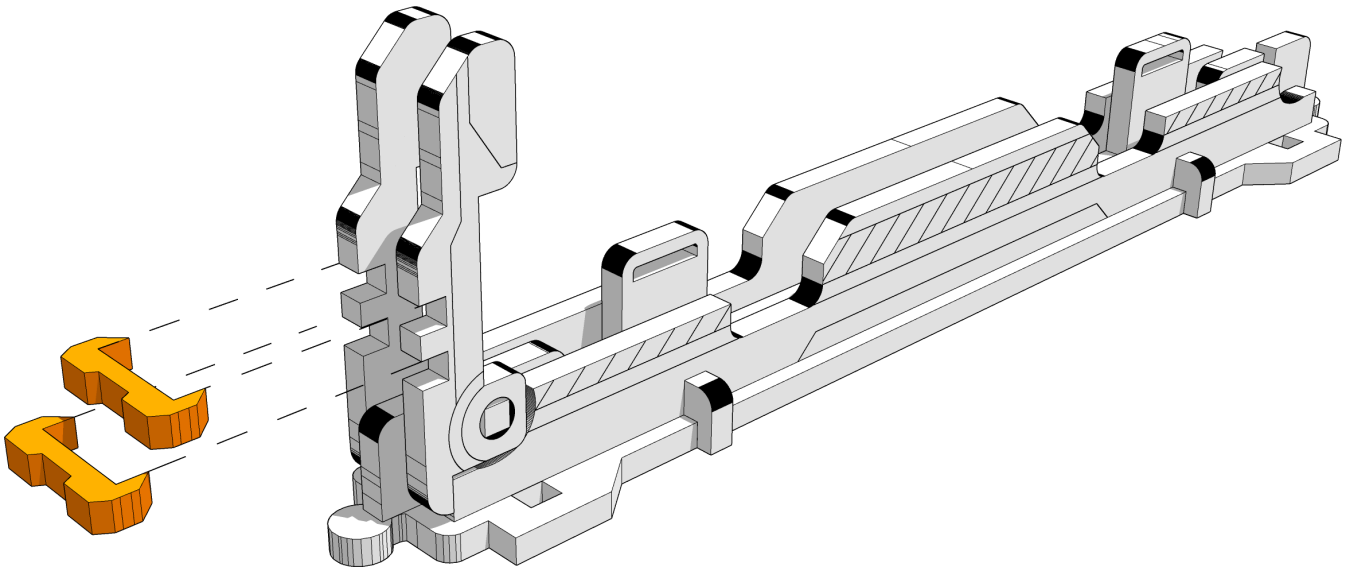



TABLETOP SCENICS

TTSCW-SFU-151
QDSC
Fences

38

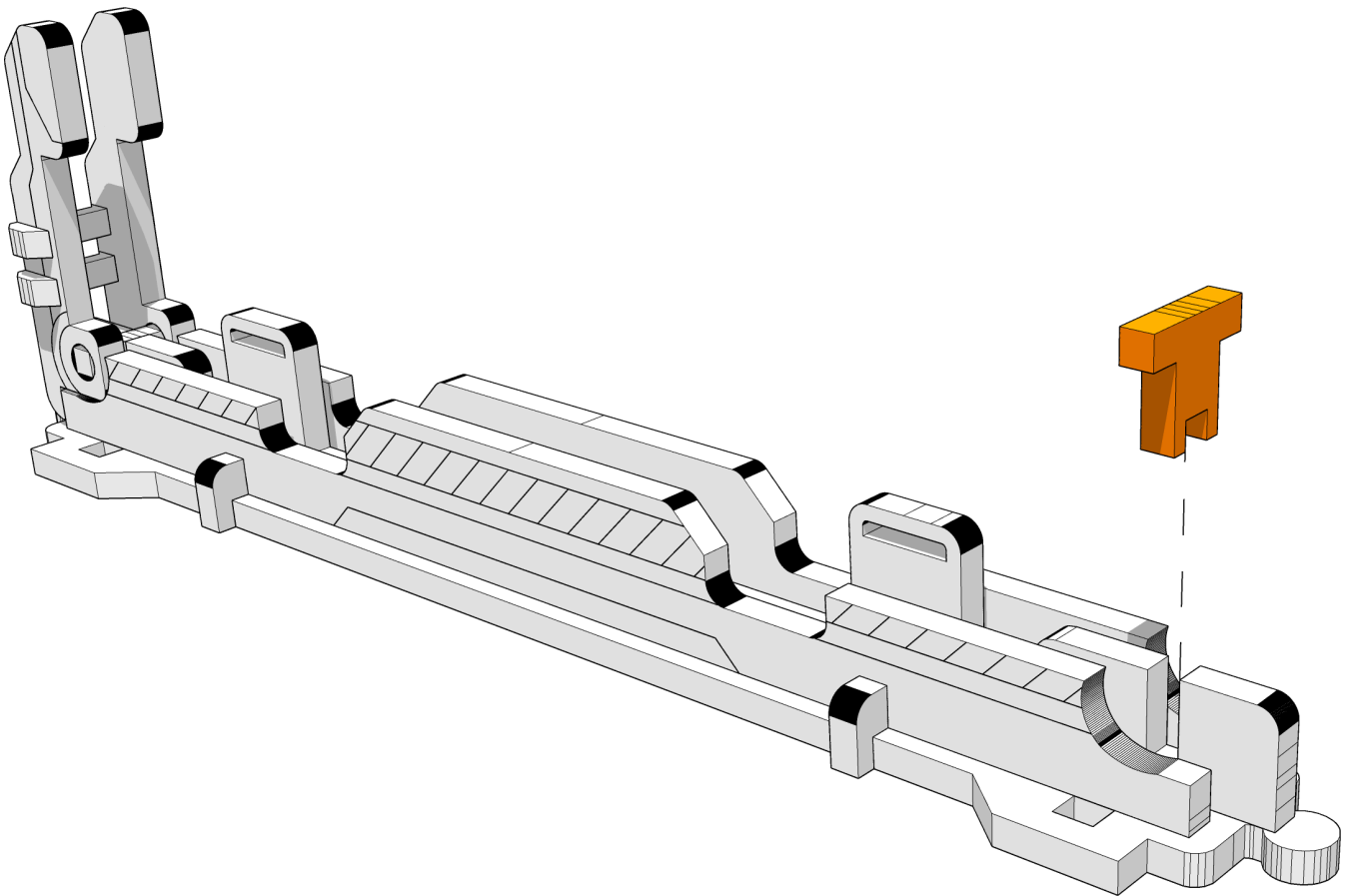



TABLETOP SCENICS

TTSCW-SFU-151
QDSC
Fences

39

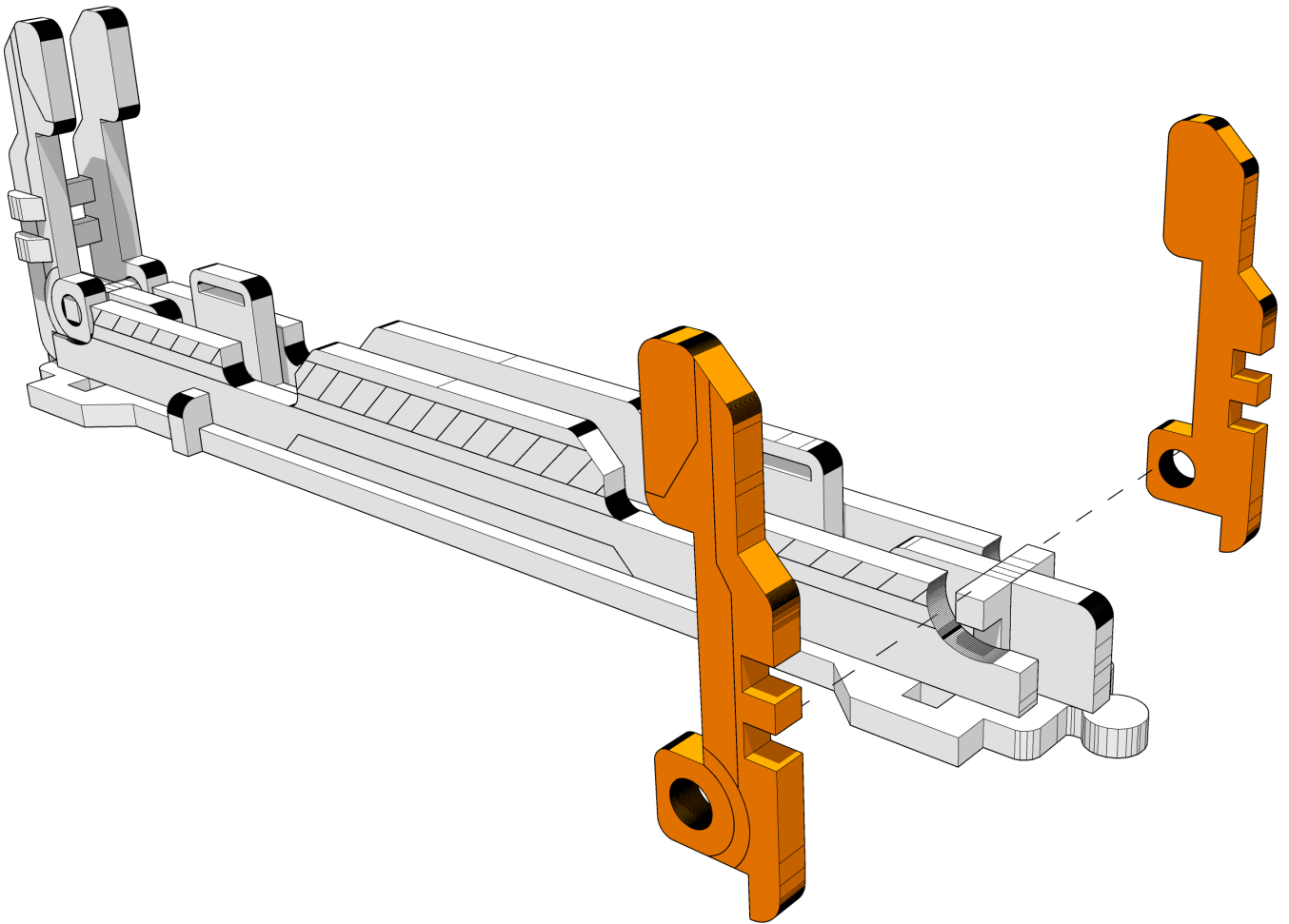

Highlighted parts are longer.
Place into position only



TABLETOP SCENICS

TTSCW-SFU-151
QDSC
Fences

40

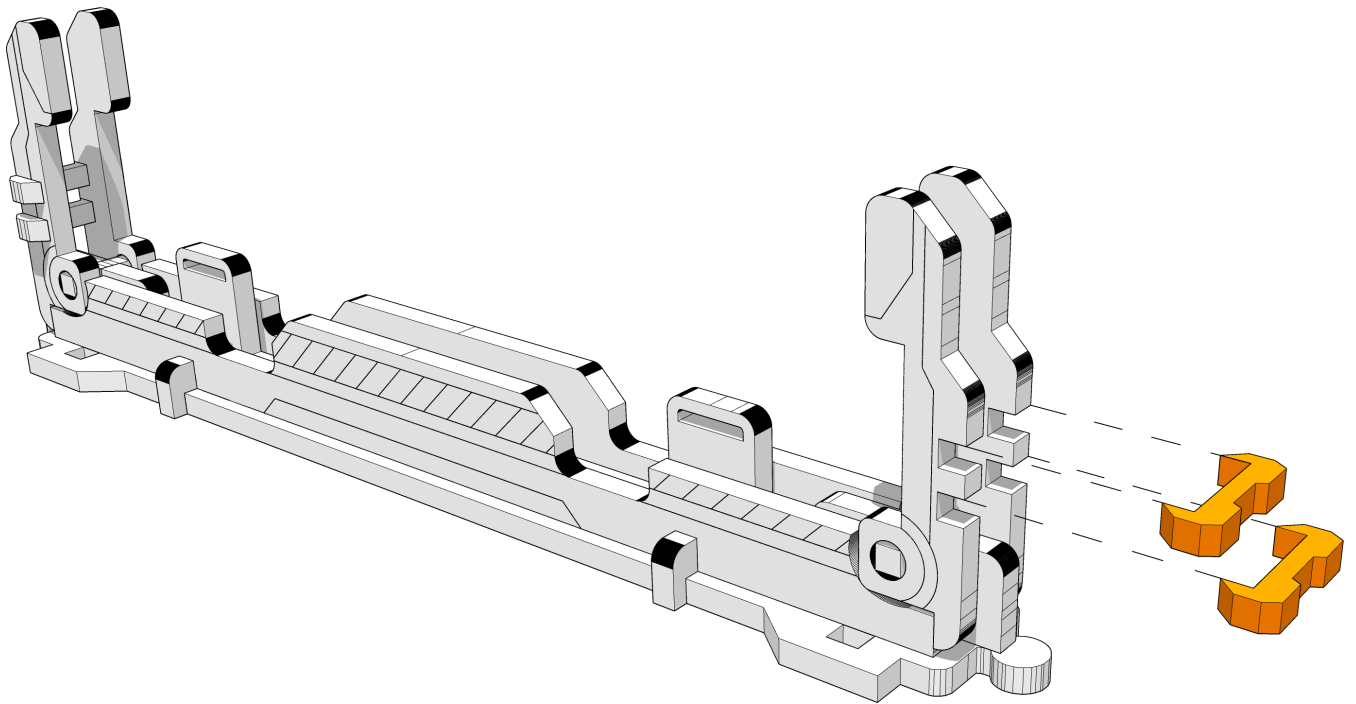



TABLETOP SCENICS

TTSCW-SFU-151
QDSC
Fences

41

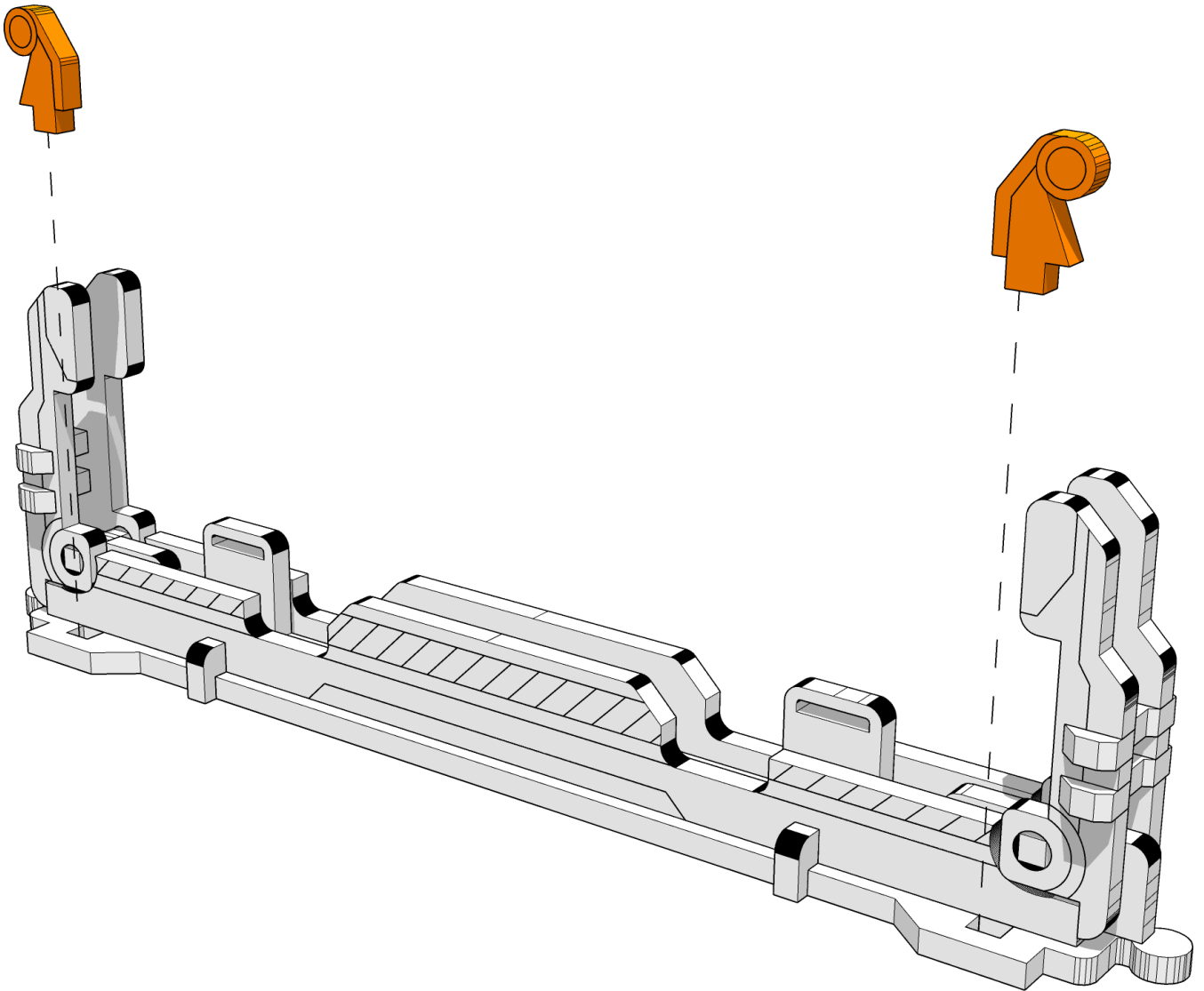

Do NOT get glue into the circular hinge





TABLETOP SCENICS

TTSCW-SFU-151
QDSC
Fences

42

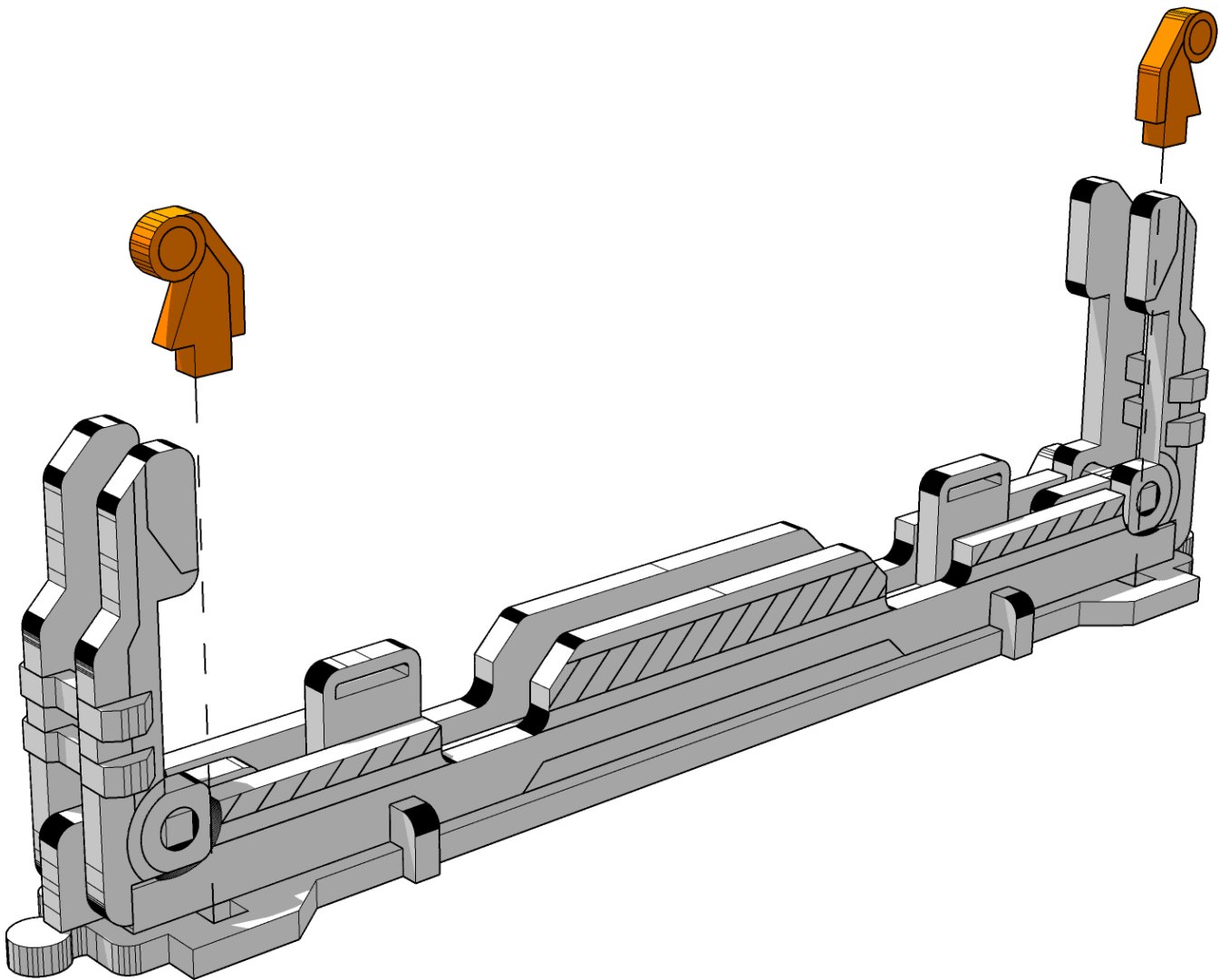



TABLETOP SCENICS

TTSCW-SFU-151
QDSC
Fences

43

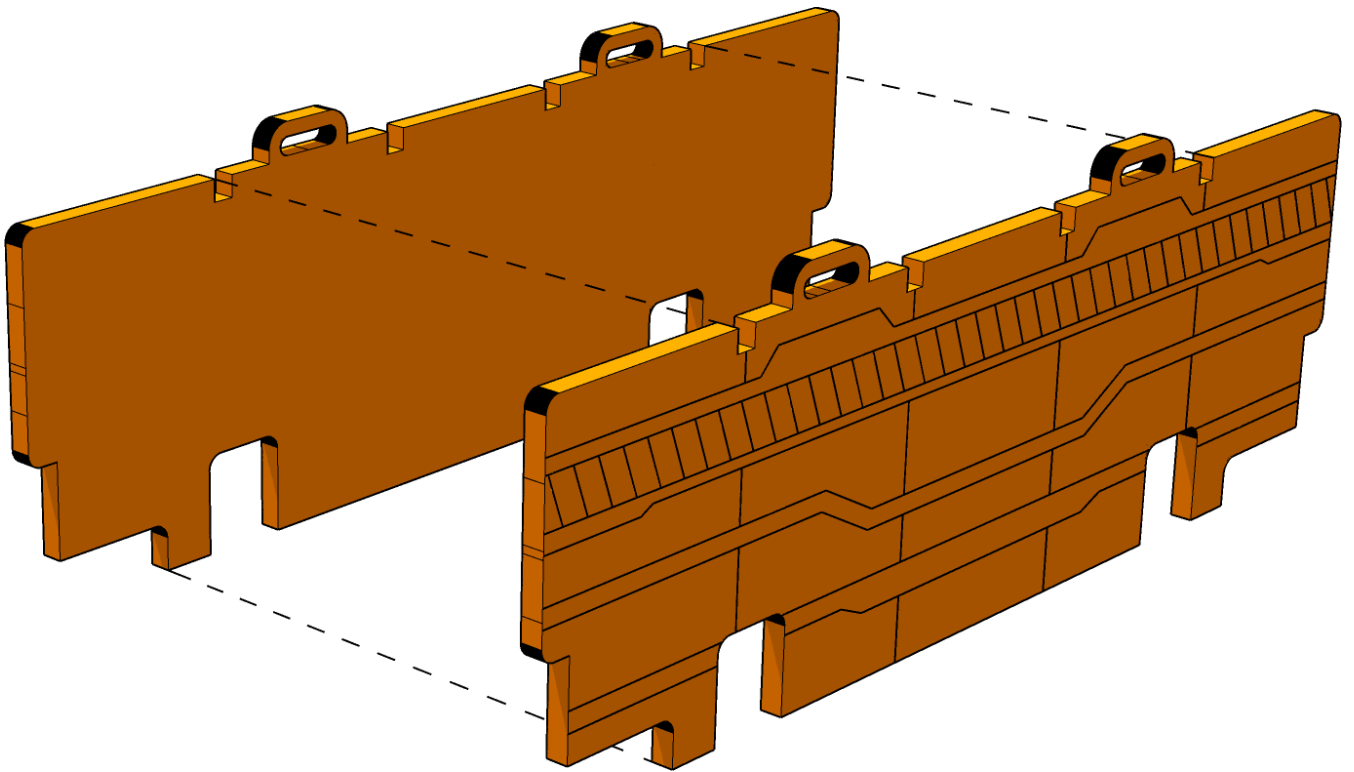



TABLETOP SCENICS

TTSCW-SFU-151
QDSC
Fences

44

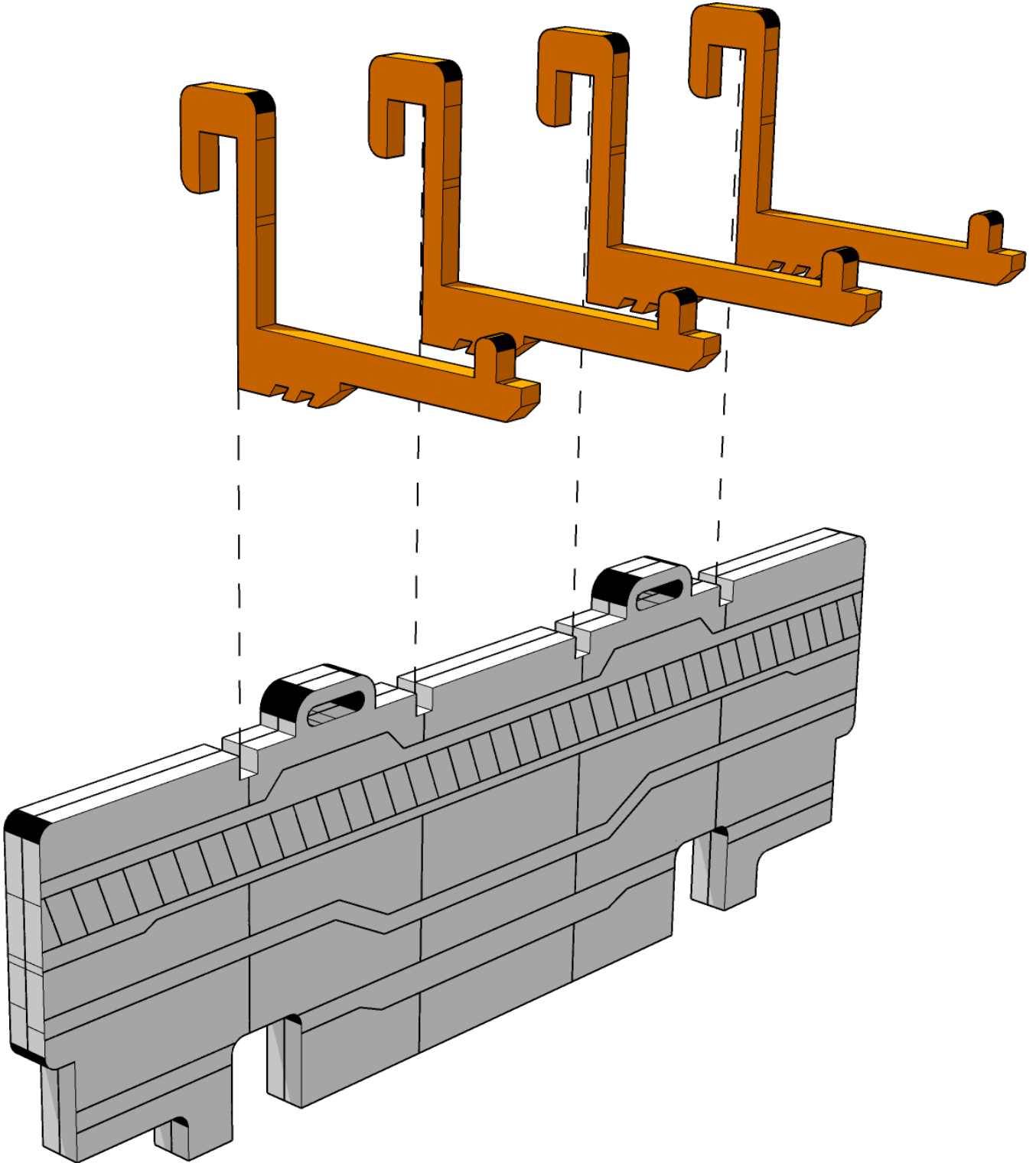



TABLETOP SCENICS

TTSCW-SFU-151
QDSC
Fences

45

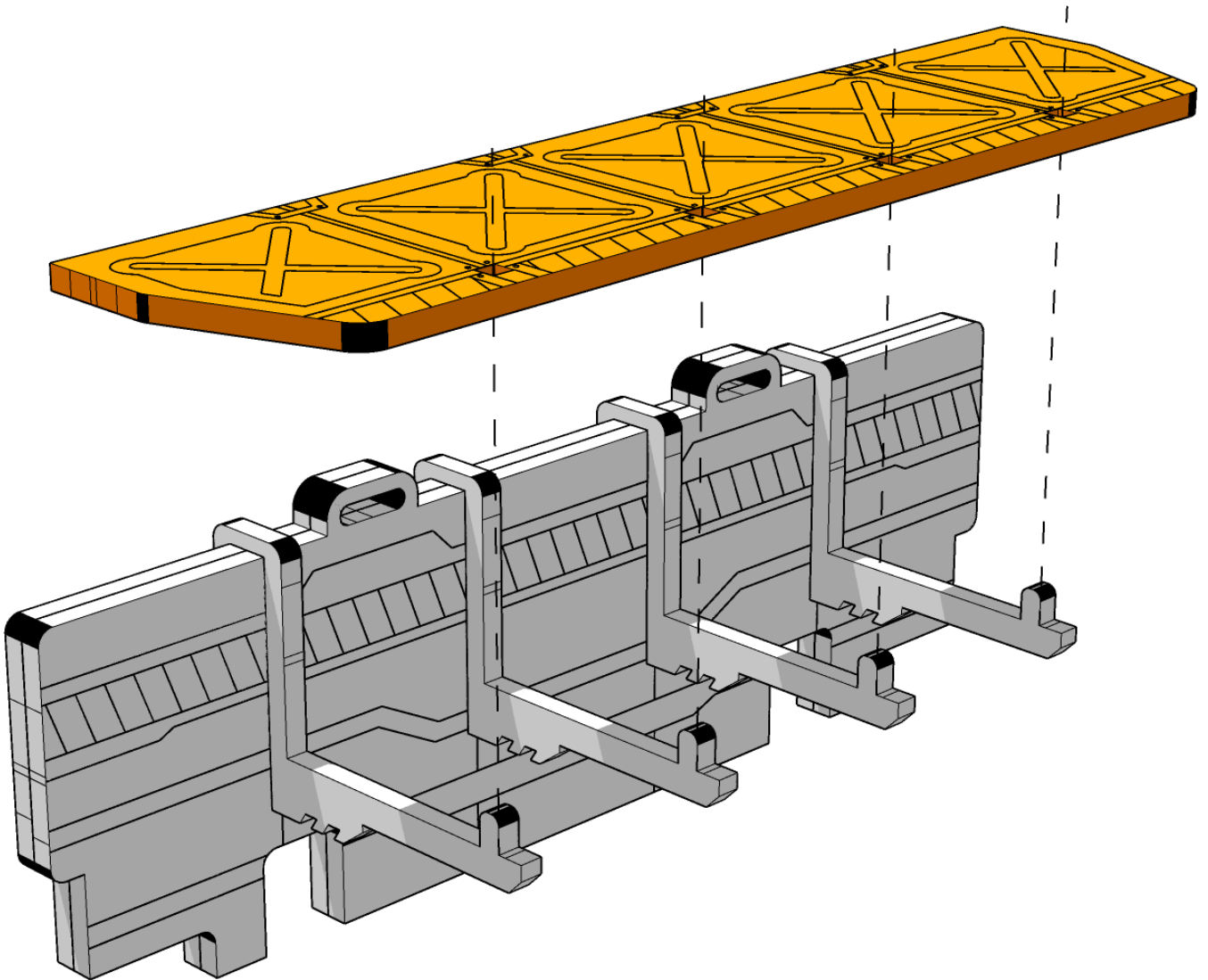



TABLETOP SCENICS

TTSCW-SFU-151
QDSC
Fences

46

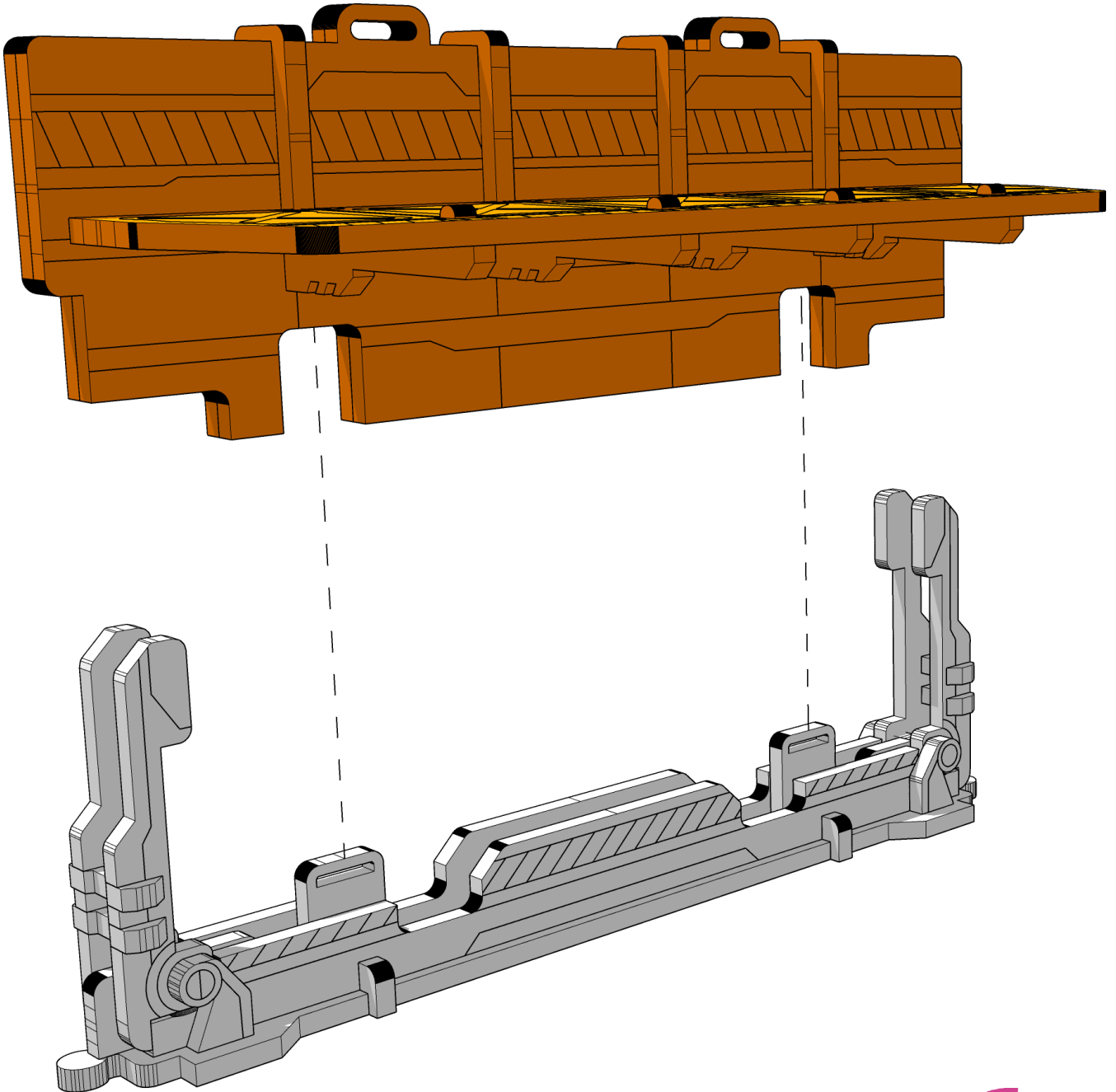

Complete fence can be made or the stand can be used
seperately



TTCOMBAT



TABLETOP SCENICS

TTSCW-SFU-151
QDSC
Fences

47

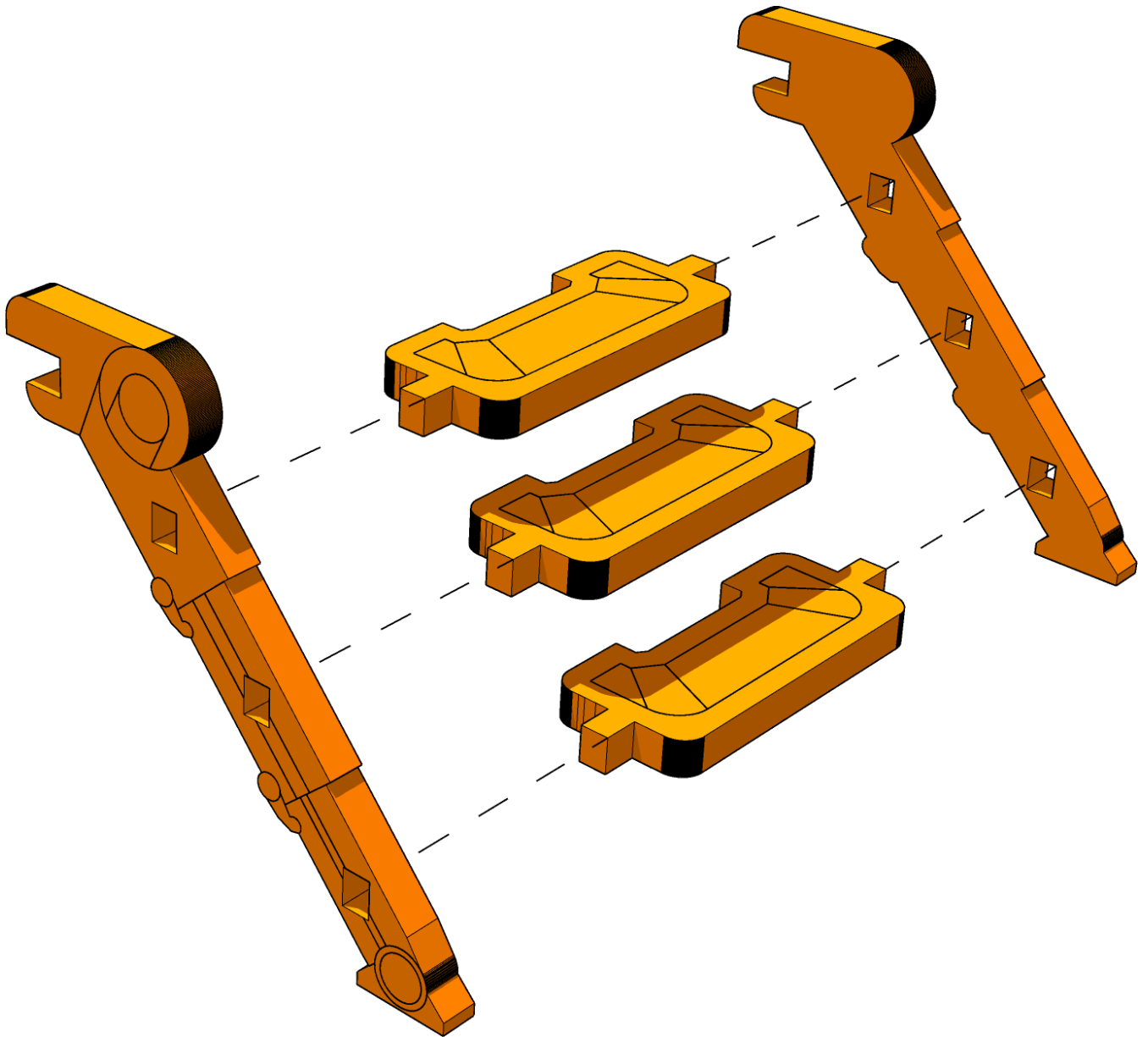



TABLETOP SCENICS

TTSCW-SFU-151
QDSC
Fences

48

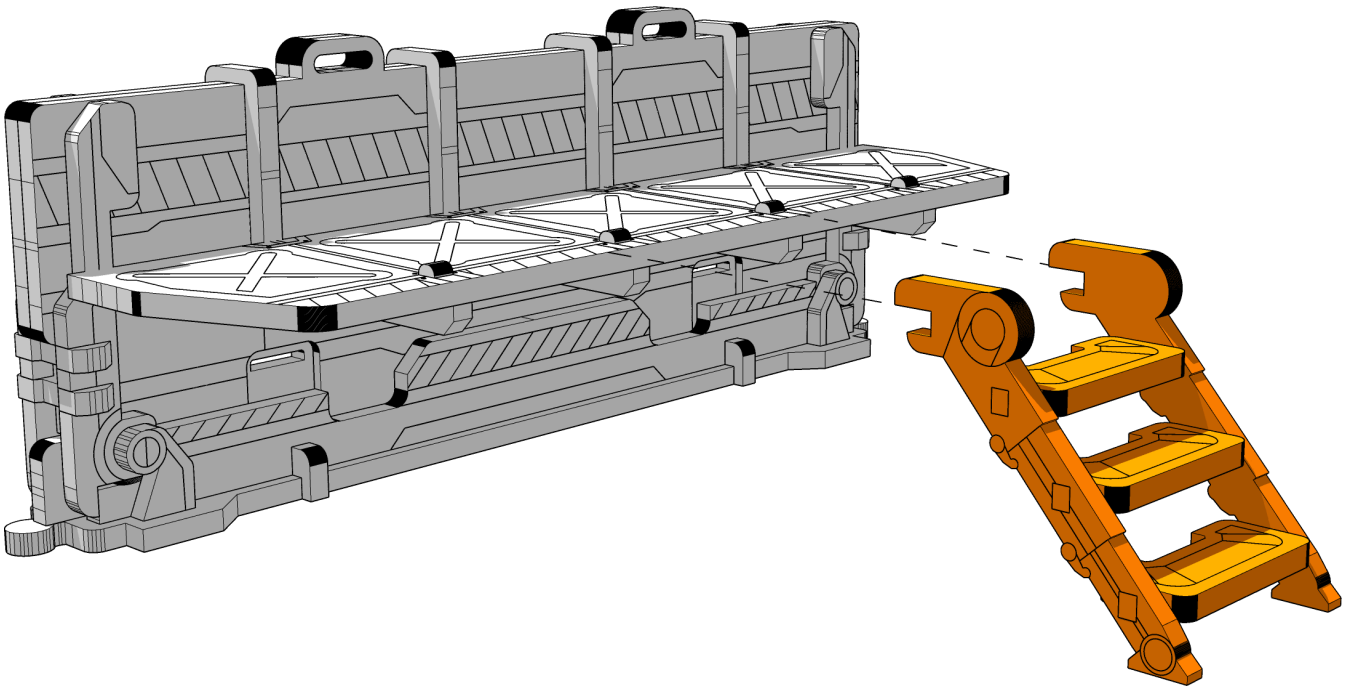



TABLETOP SCENICS

TTSCW-SFU-151
QDSC
Fences

49

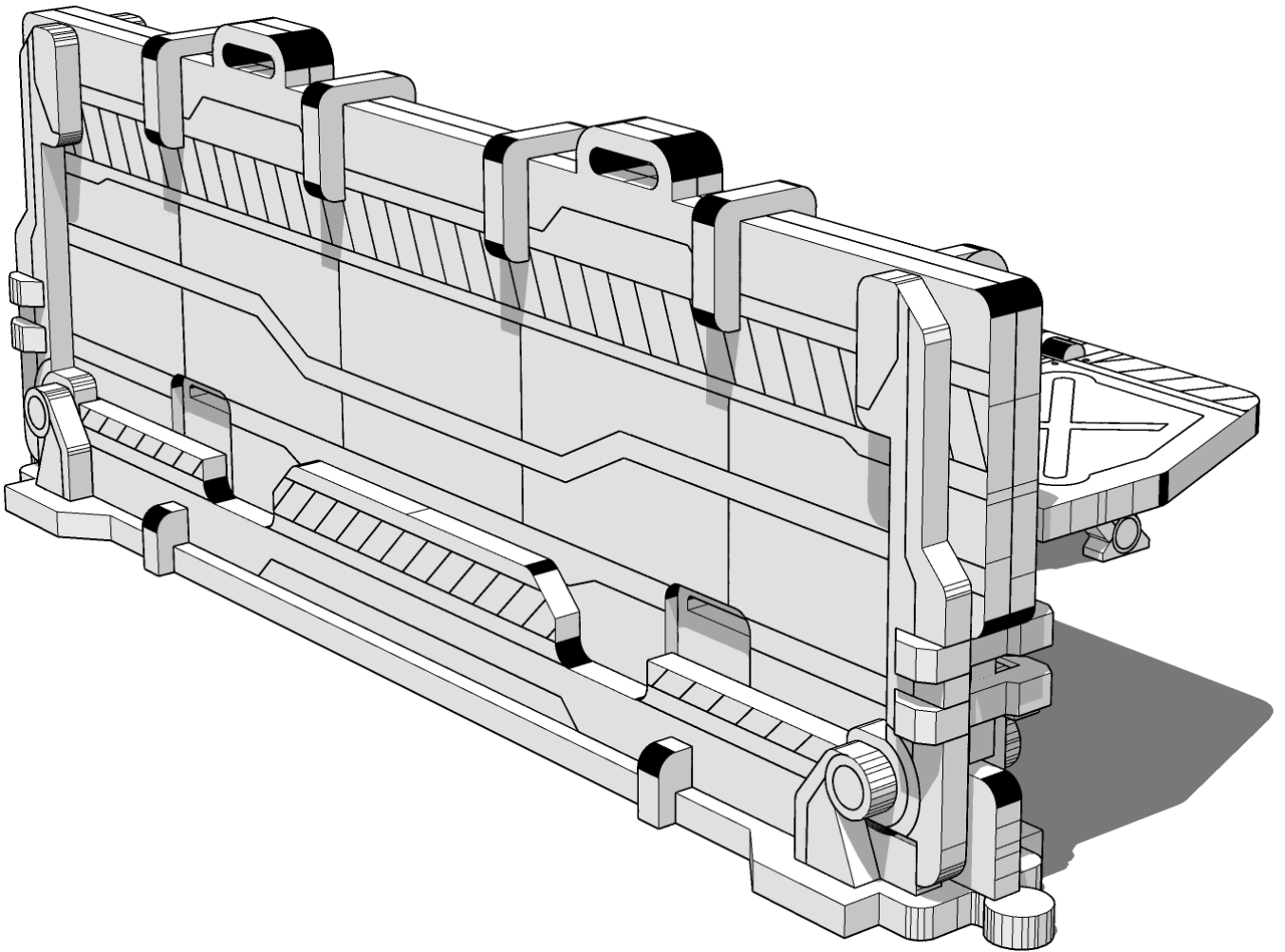

 **TTCOMBAT**



TABLETOP SCENICS

TTSCW-SFU-151
QDSC
Fences

50

