

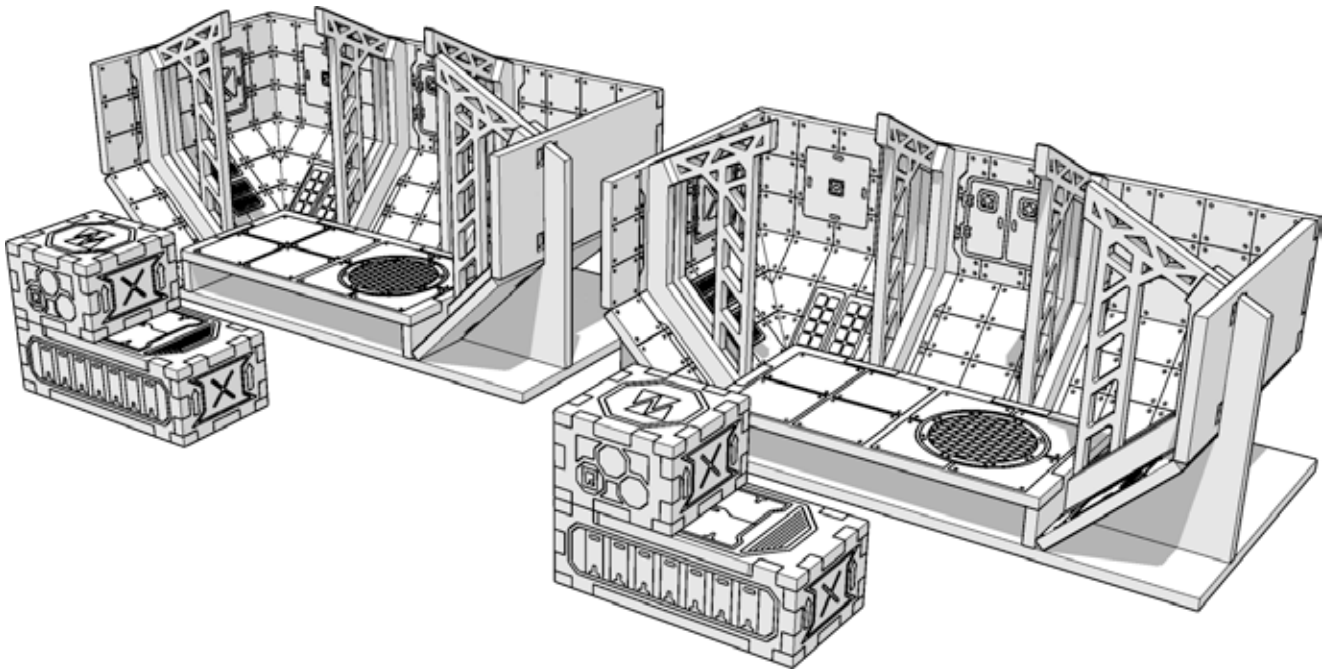

TABLETOP SCENICS

TTSCW-SFU-117
Mod.Co.N
Dead End Sections



 **TTCOMBAT**



TABLETOP SCENICS

TTSCW-SFU-117 Mod.Co.N Dead End Sections

2

These are a series of icons that may be used throughout the instructions to help your assembly.
If in doubt, scroll ahead to confirm.



Do not glue this part



Carefully score and
fold this part

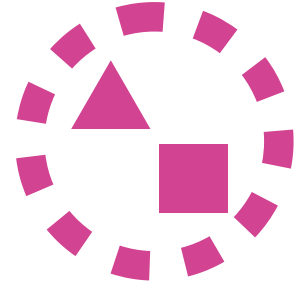

This part - or its placement is
completely optional

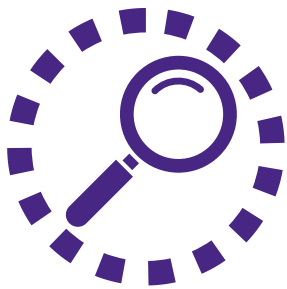

Look closely at this step -
The process order or part
used, may be specific



Repeat making this part
the specified number
of times

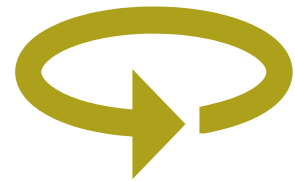

The next instruction step
will be the same assembly
so far, but from a different
angle

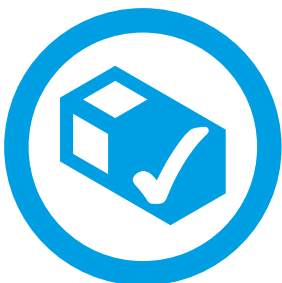

Sub-assembly complete.
This smaller construction
is ready to add to the
main kit



Assembly Complete! There
could be more optional
parts - check to the very end
of instructions



FRAGILE: DO NOT BEND.
“Bendy wood” is designed to
curve around a designed
frame only.



TABLETOP SCENICS

TTSCW-SFU-117
Mod.Co.N
Dead End Sections

3

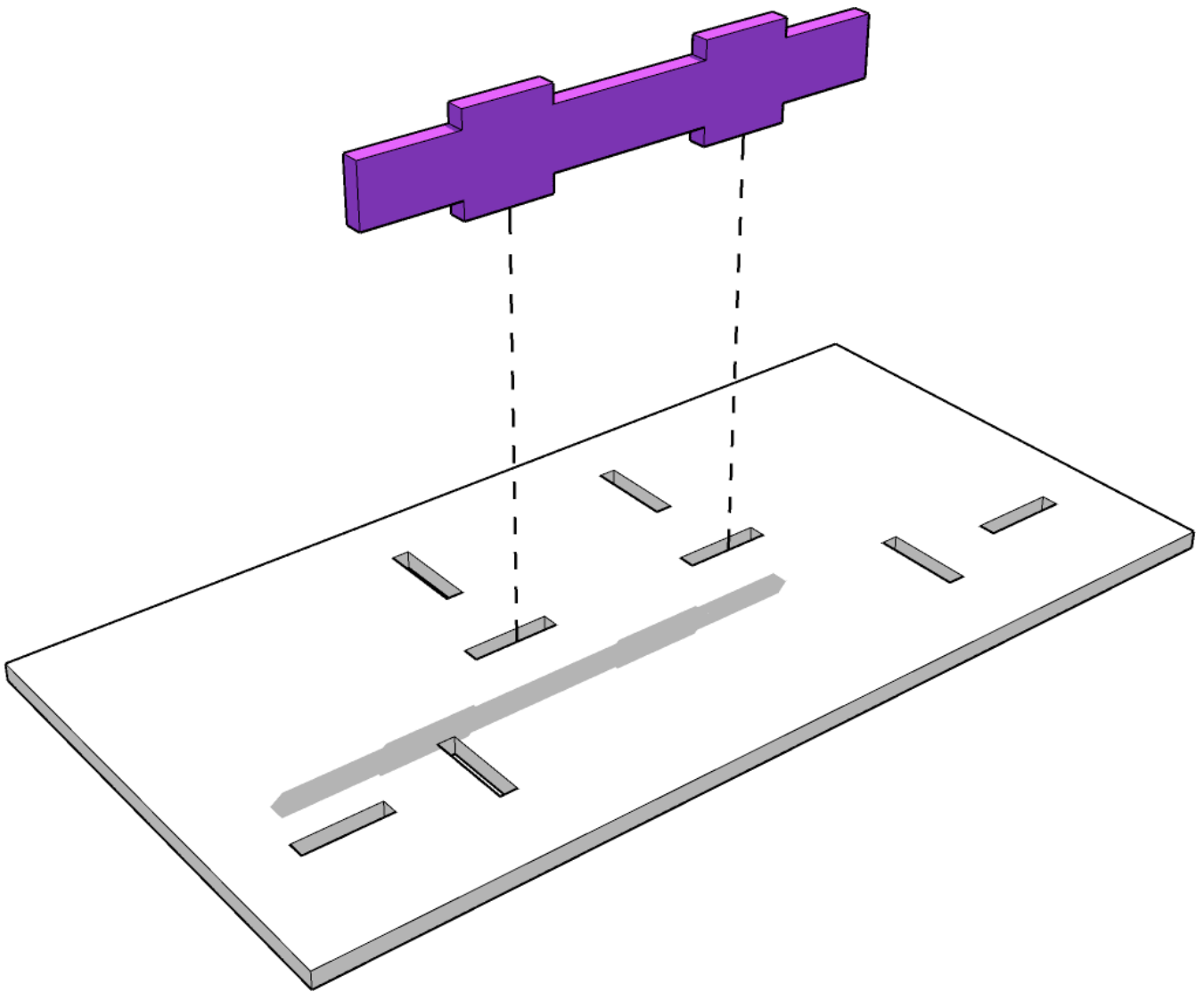



TABLETOP SCENICS

TTSCW-SFU-117
Mod.Co.N
Dead End Sections

4

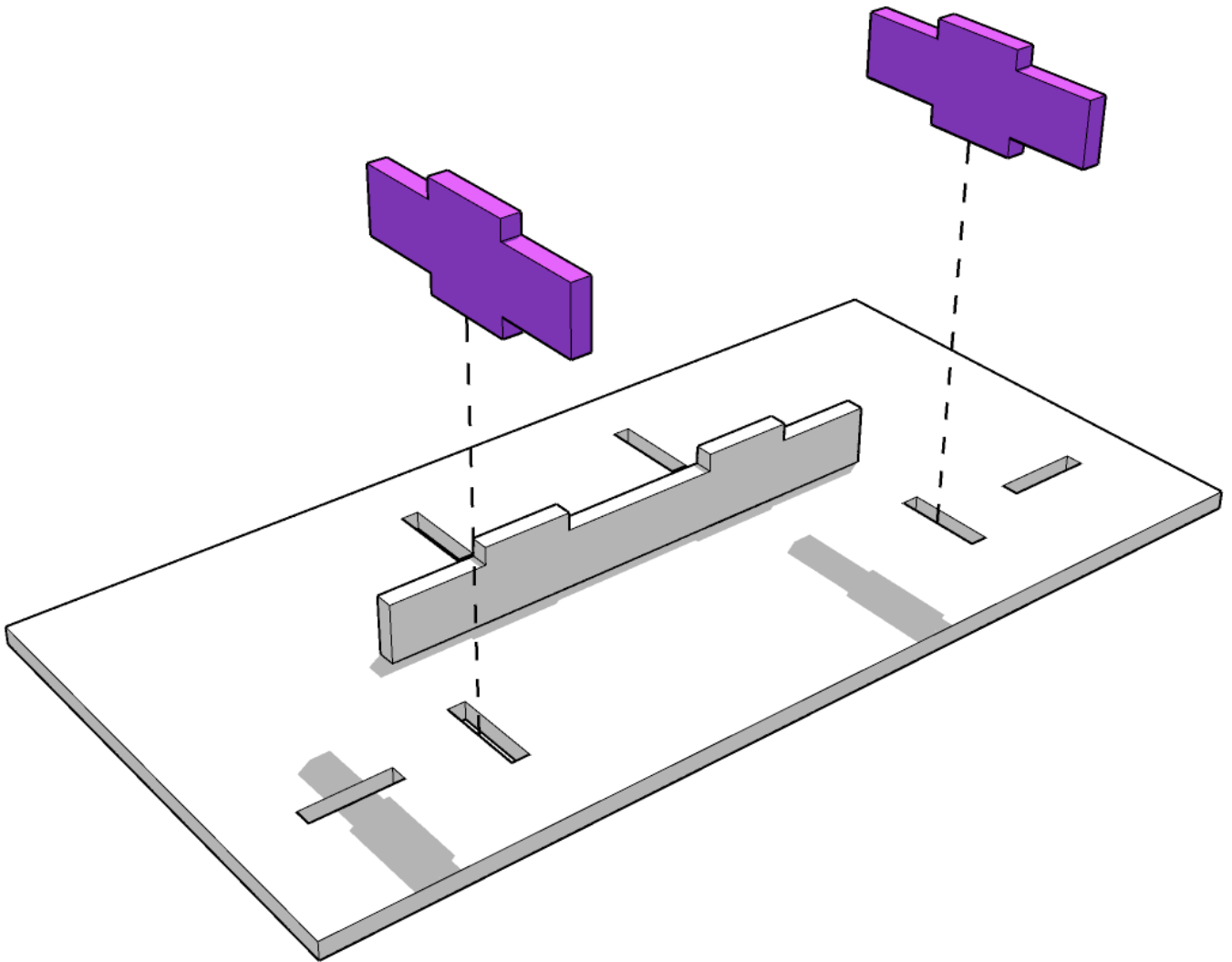



TABLETOP SCENICS

TTSCW-SFU-117
Mod.Co.N
Dead End Sections

5

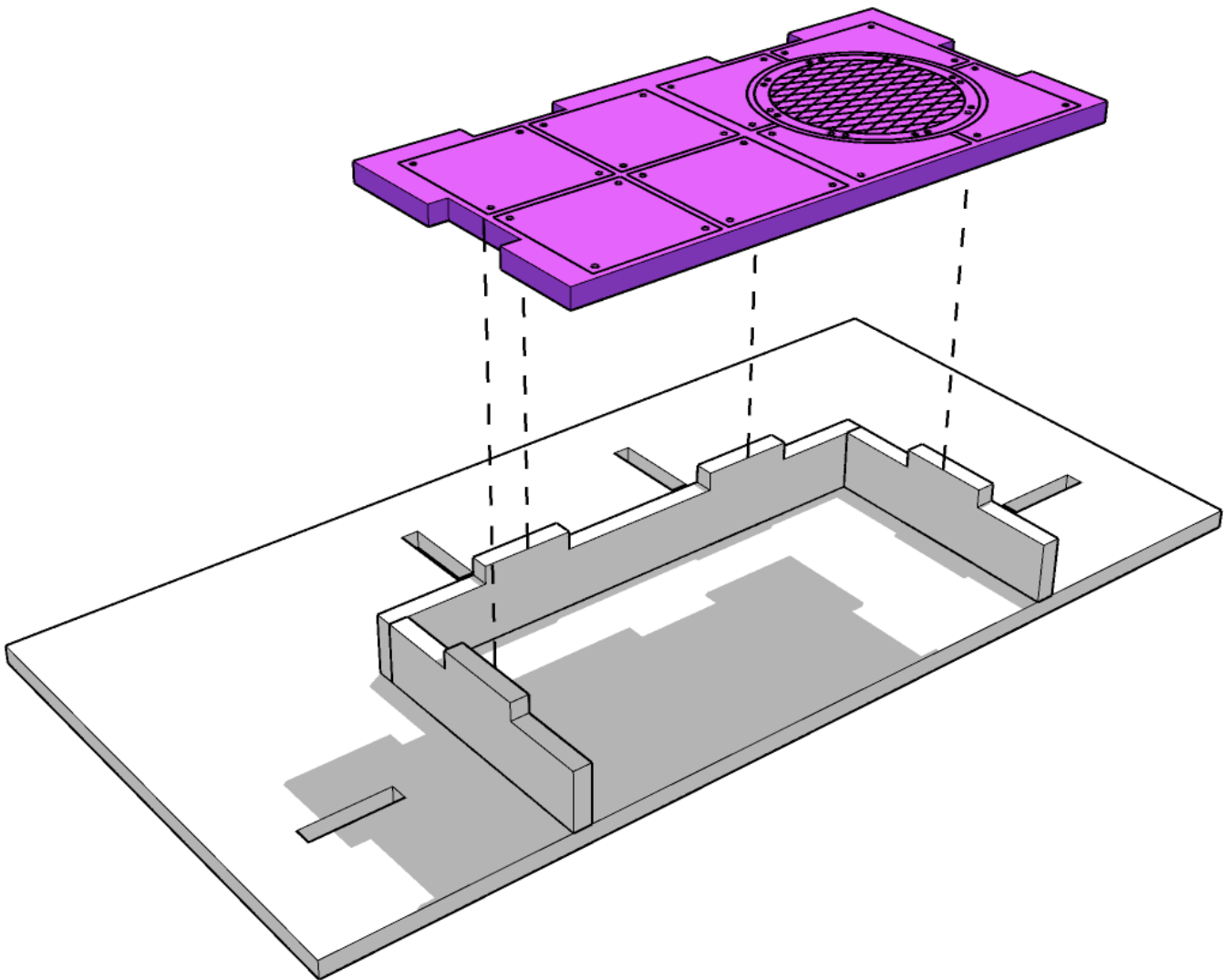



TABLETOP SCENICS

TTSCW-SFU-117
Mod.Co.N
Dead End Sections

6

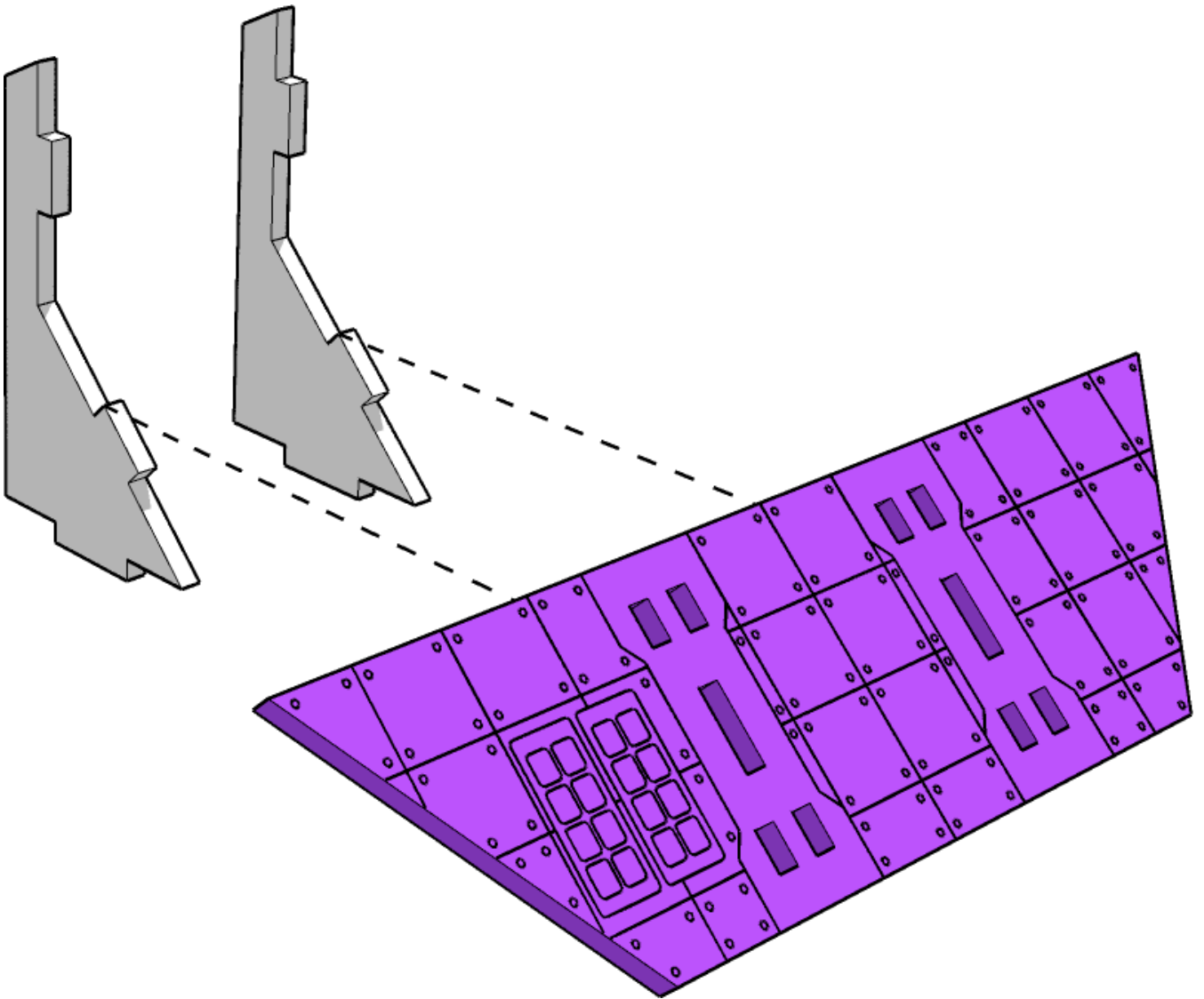



TABLETOP SCENICS

TTSCW-SFU-117
Mod.Co.N
Dead End Sections

7

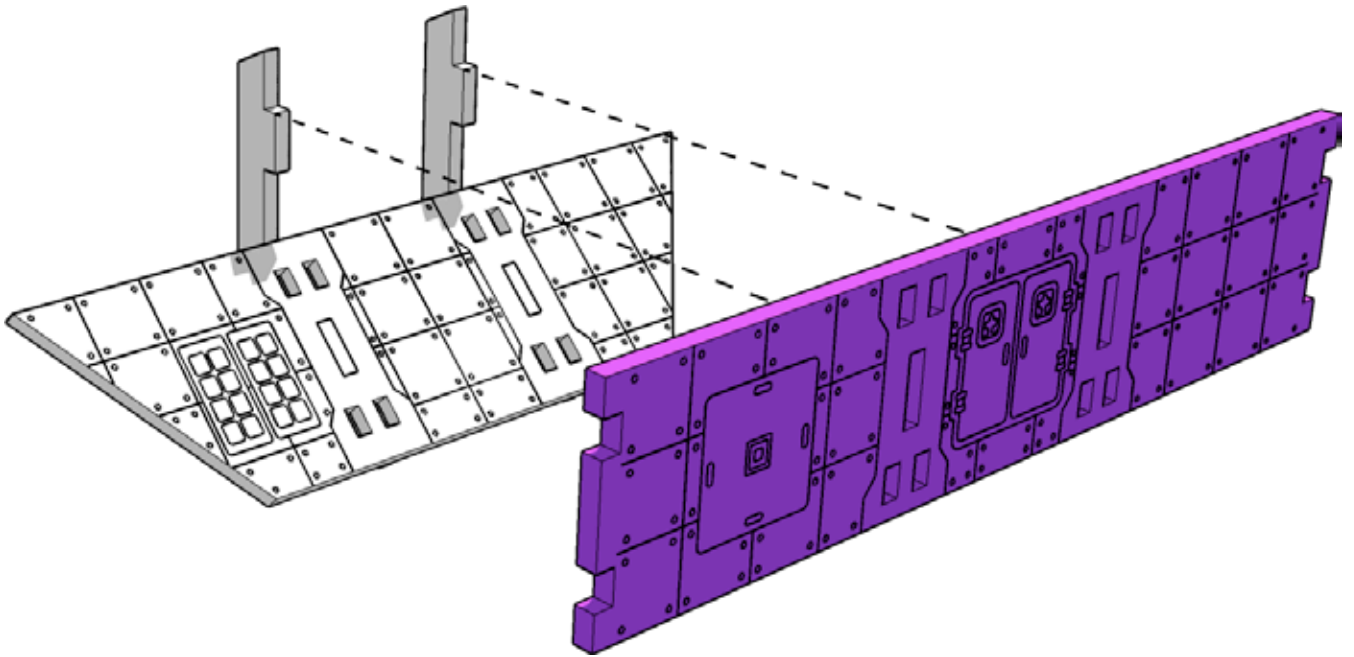



TABLETOP SCENICS

TTSCW-SFU-117
Mod.Co.N
Dead End Sections

8

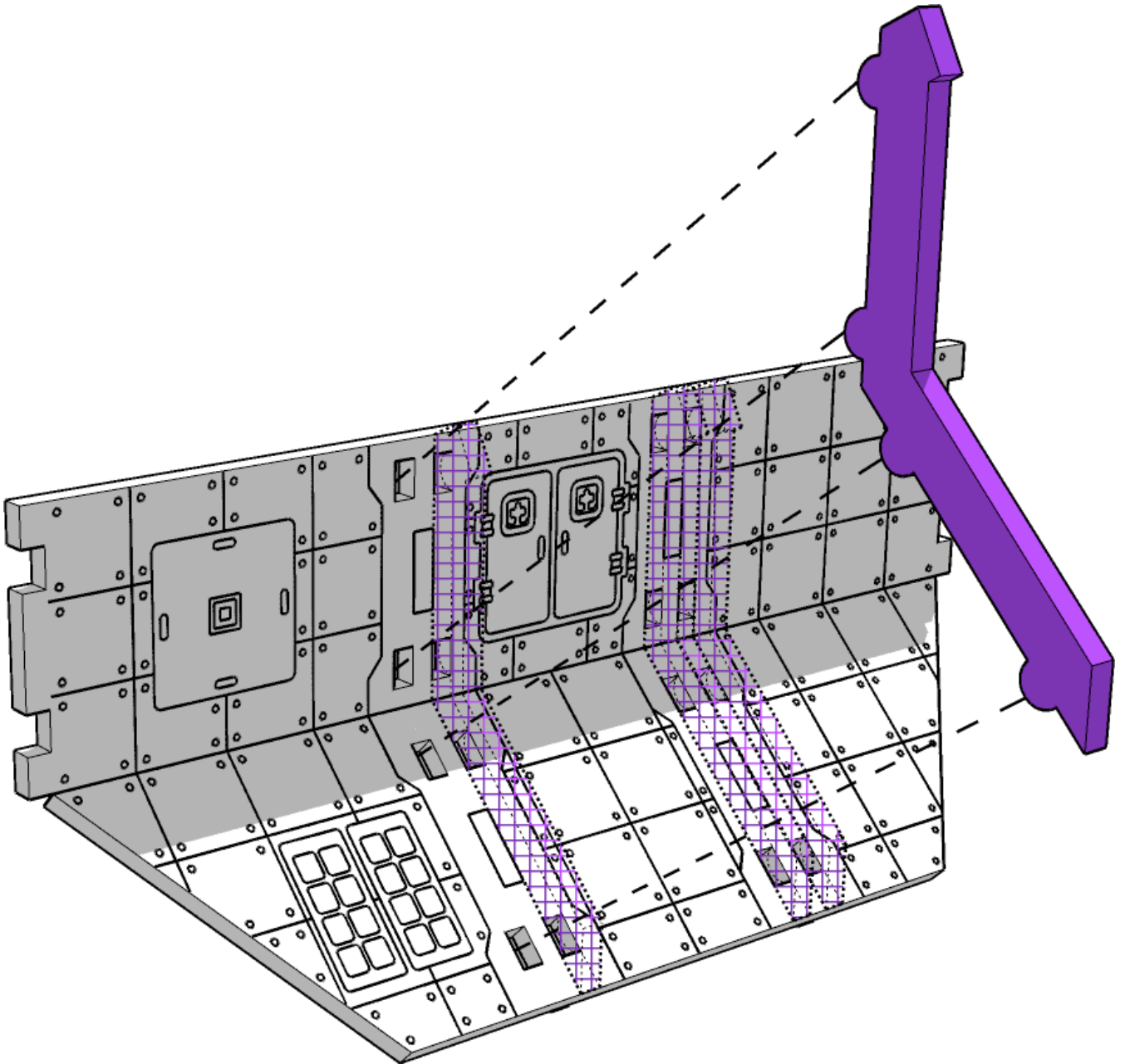



TABLETOP SCENICS

TTSCW-SFU-117
Mod.Co.N
Dead End Sections

9

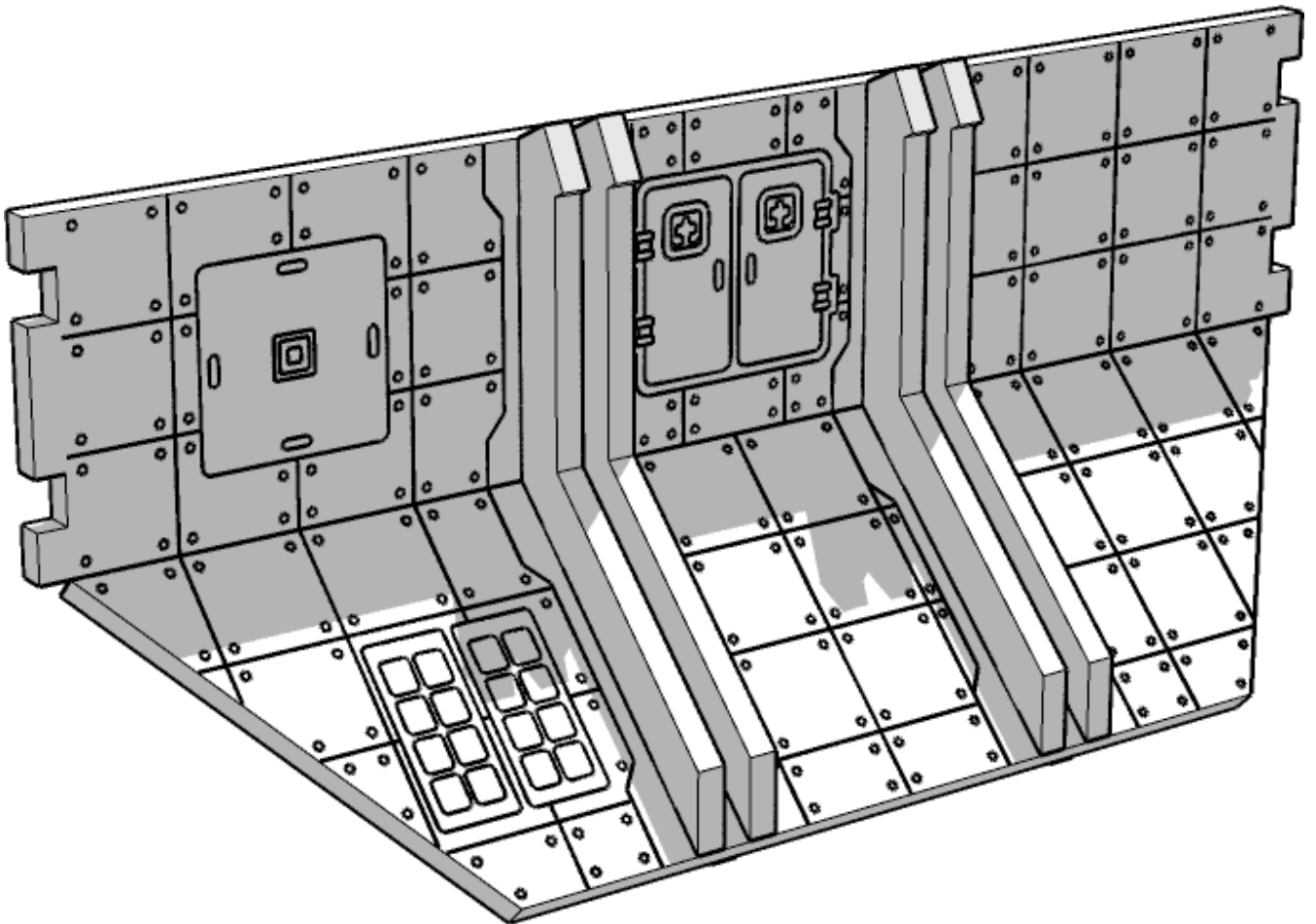



TABLETOP SCENICS

TTSCW-SFU-117
Mod.Co.N
Dead End Sections

10

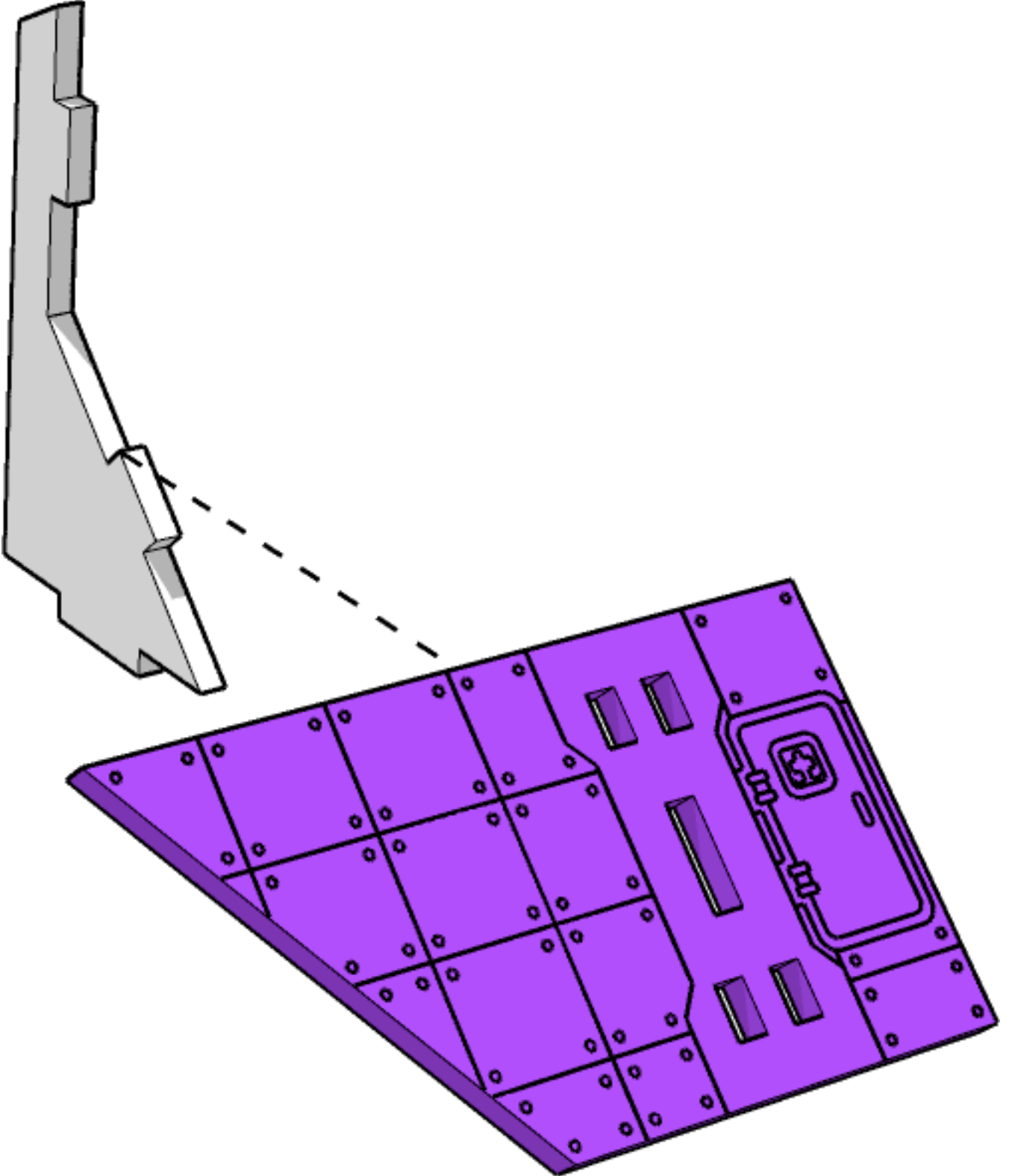



TABLETOP SCENICS

TTSCW-SFU-117
Mod.Co.N
Dead End Sections

11

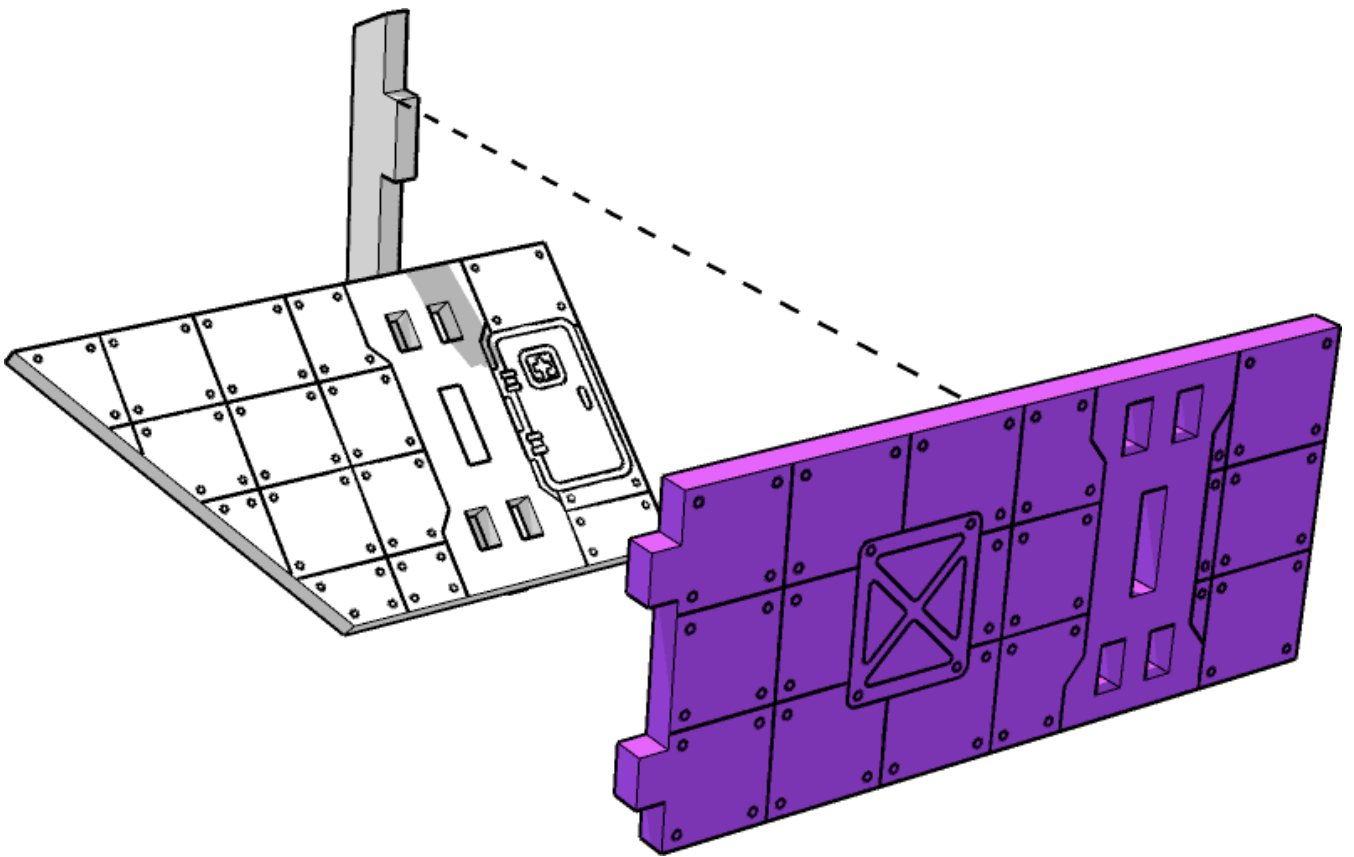



TABLETOP SCENICS

12

TTSCW-SFU-117
Mod.Co.N
Dead End Sections

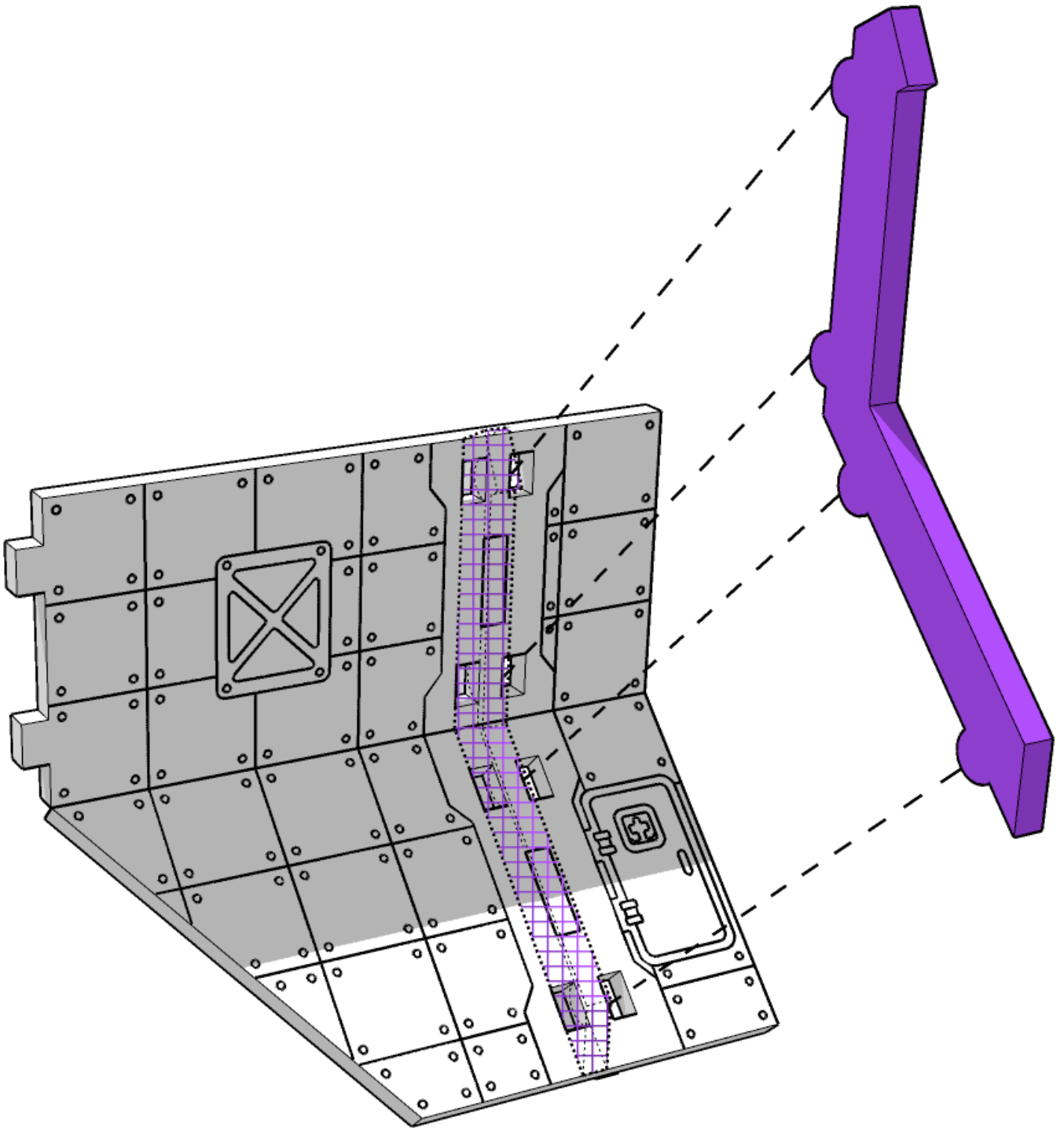



TABLETOP SCENICS

TTSCW-SFU-117
Mod.Co.N
Dead End Sections

13

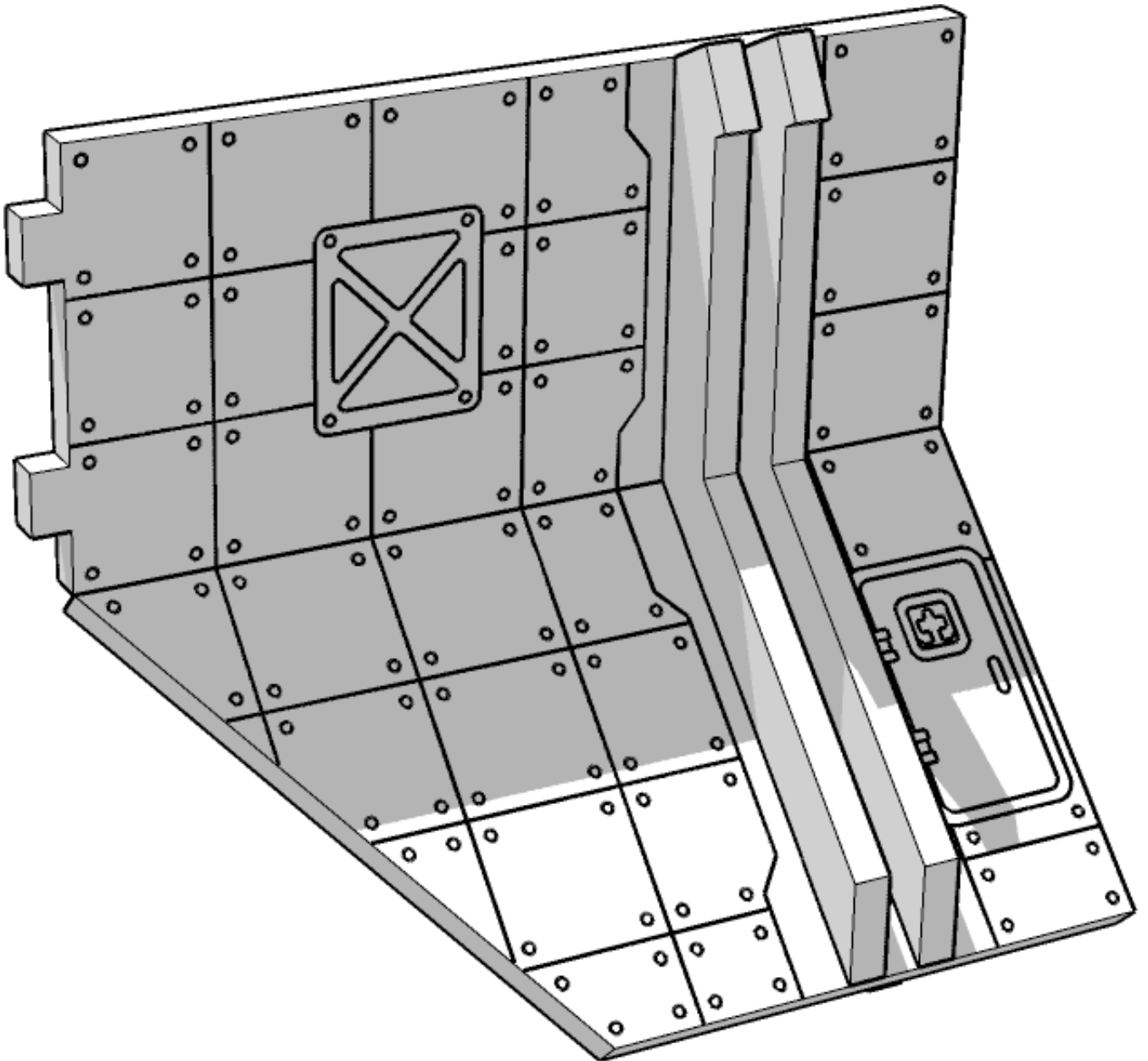



TABLETOP SCENICS

TTSCW-SFU-117
Mod.Co.N
Dead End Sections

14

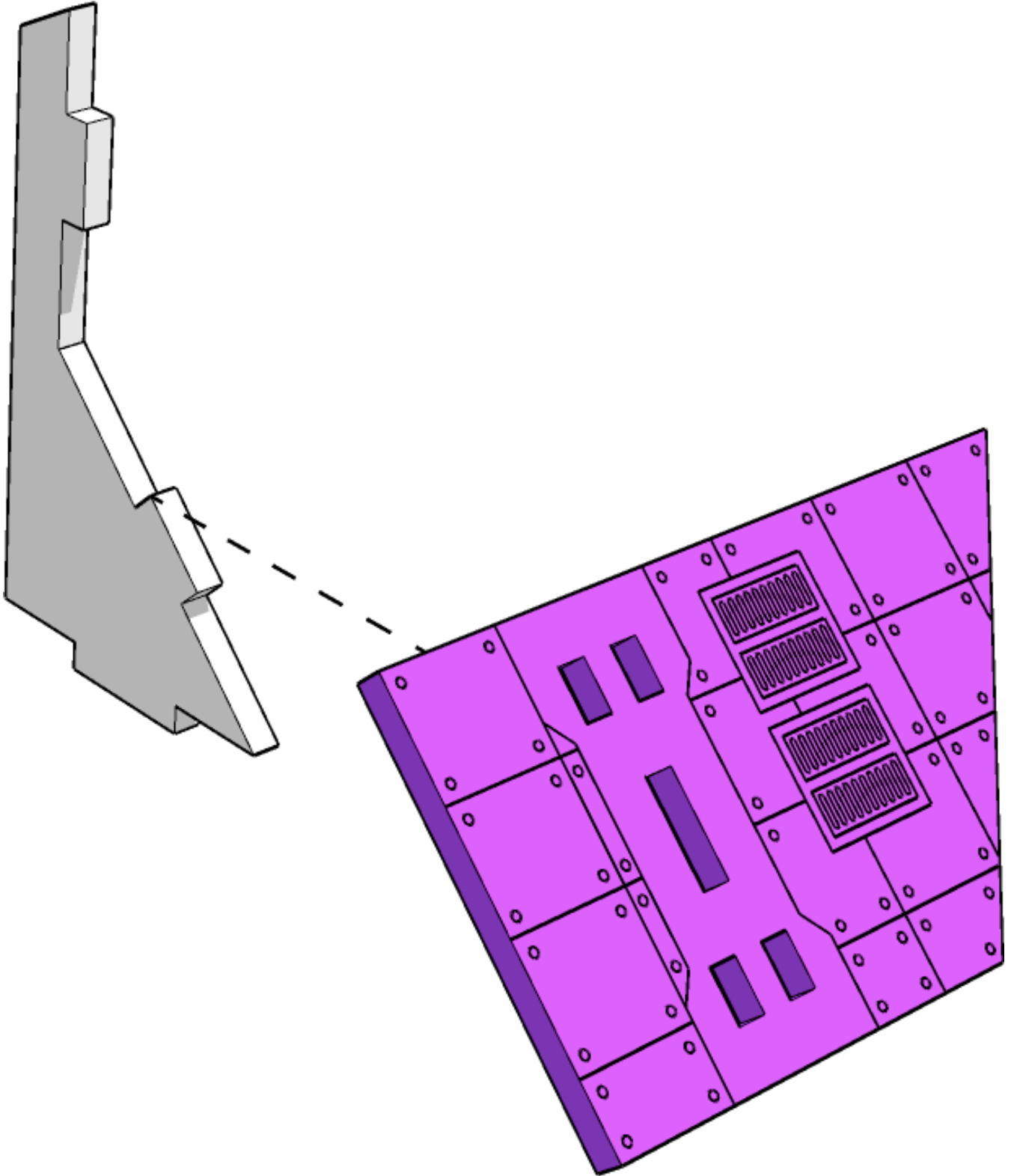



TABLETOP SCENICS

TTSCW-SFU-117
Mod.Co.N
Dead End Sections

15

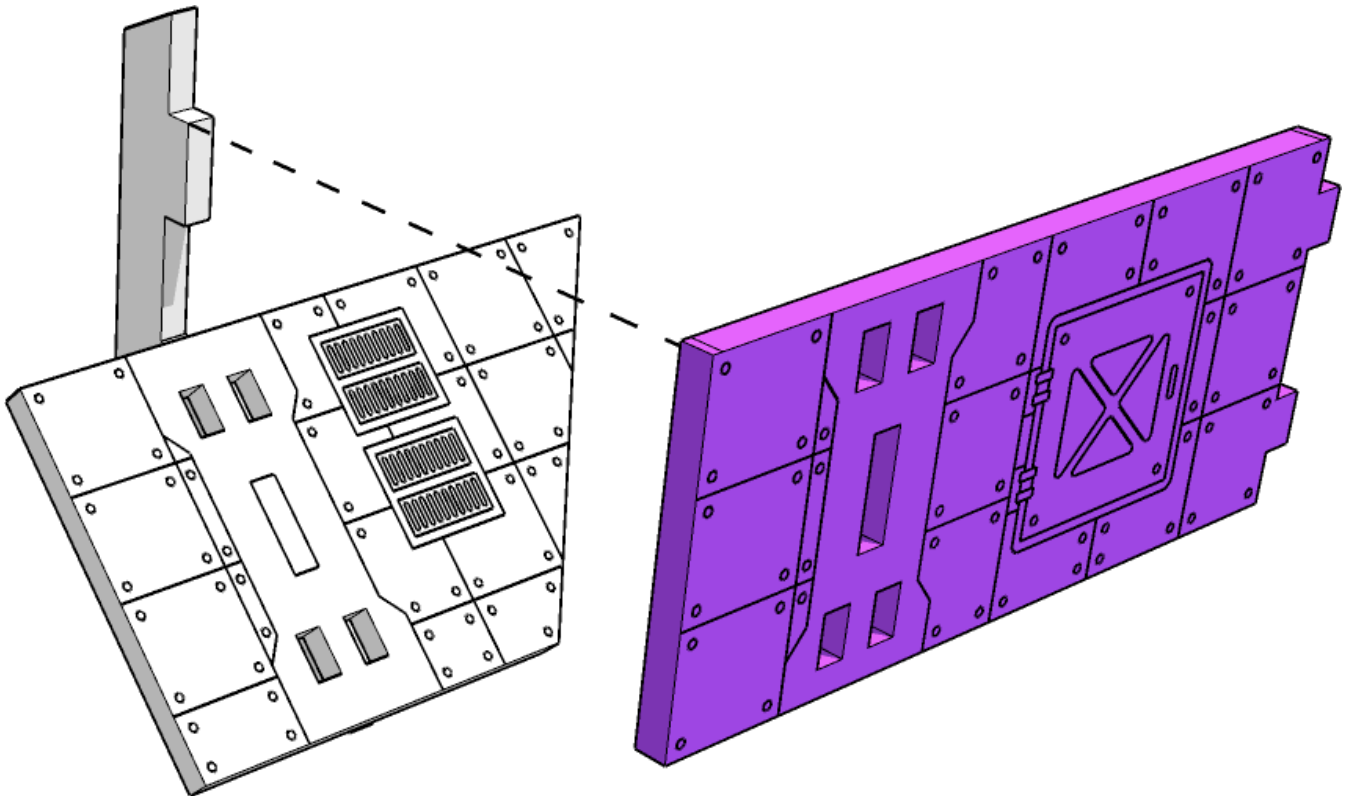



TABLETOP SCENICS

TTSCW-SFU-117
Mod.Co.N
Dead End Sections

16

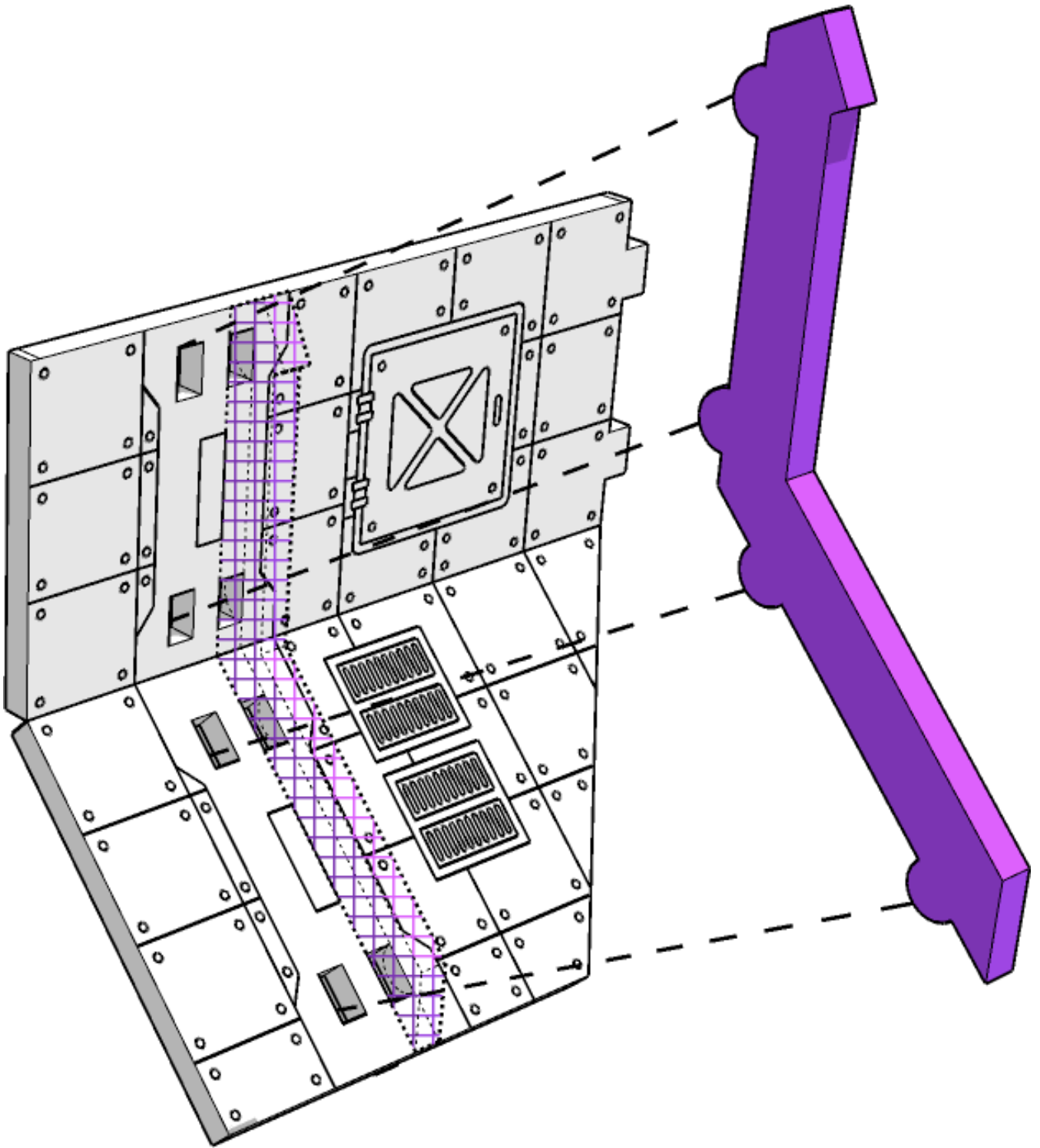



TABLETOP SCENICS

TTSCW-SFU-117
Mod.Co.N
Dead End Sections

17

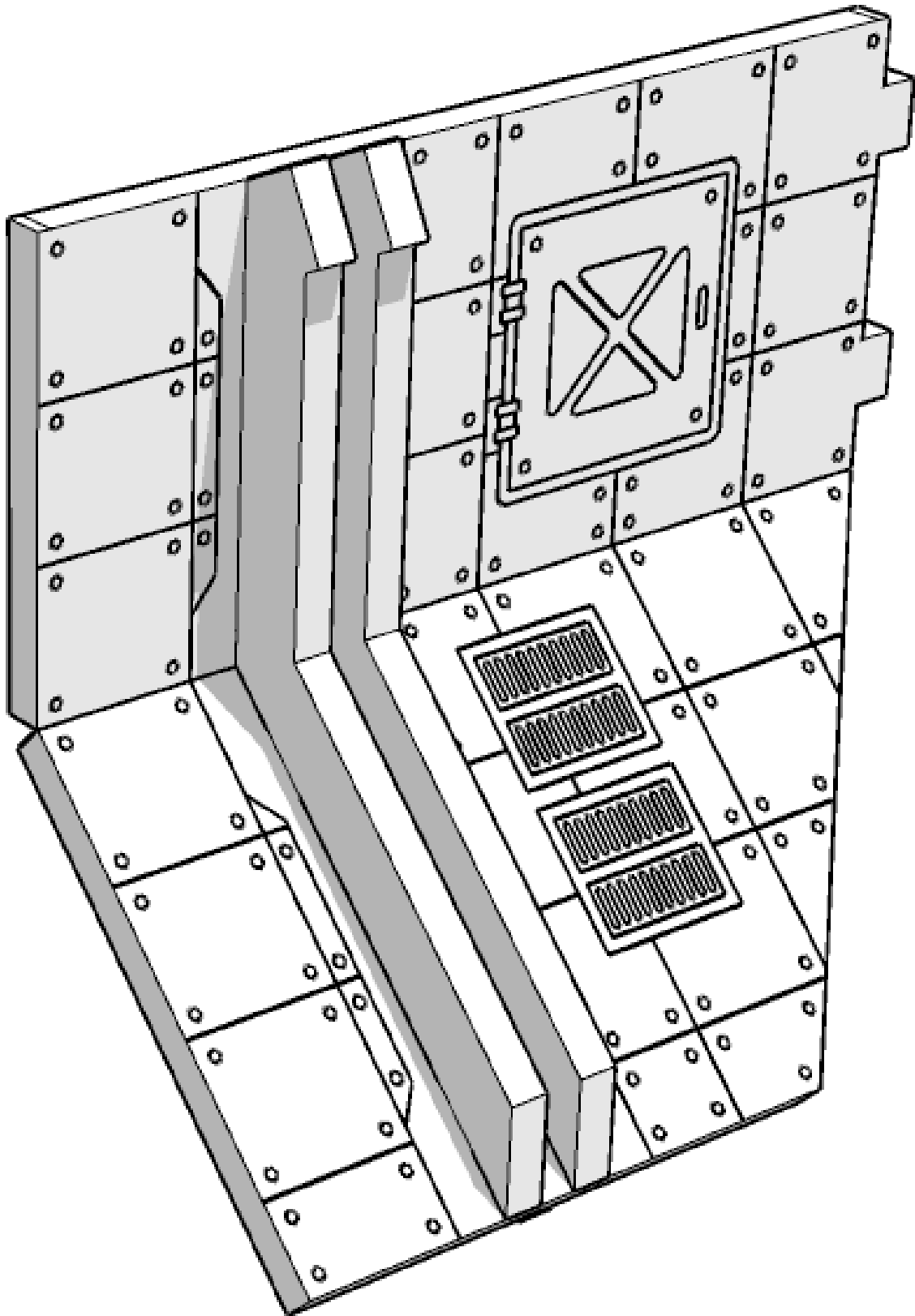



TABLETOP SCENICS

TTSCW-SFU-117
Mod.Co.N
Dead End Sections

18

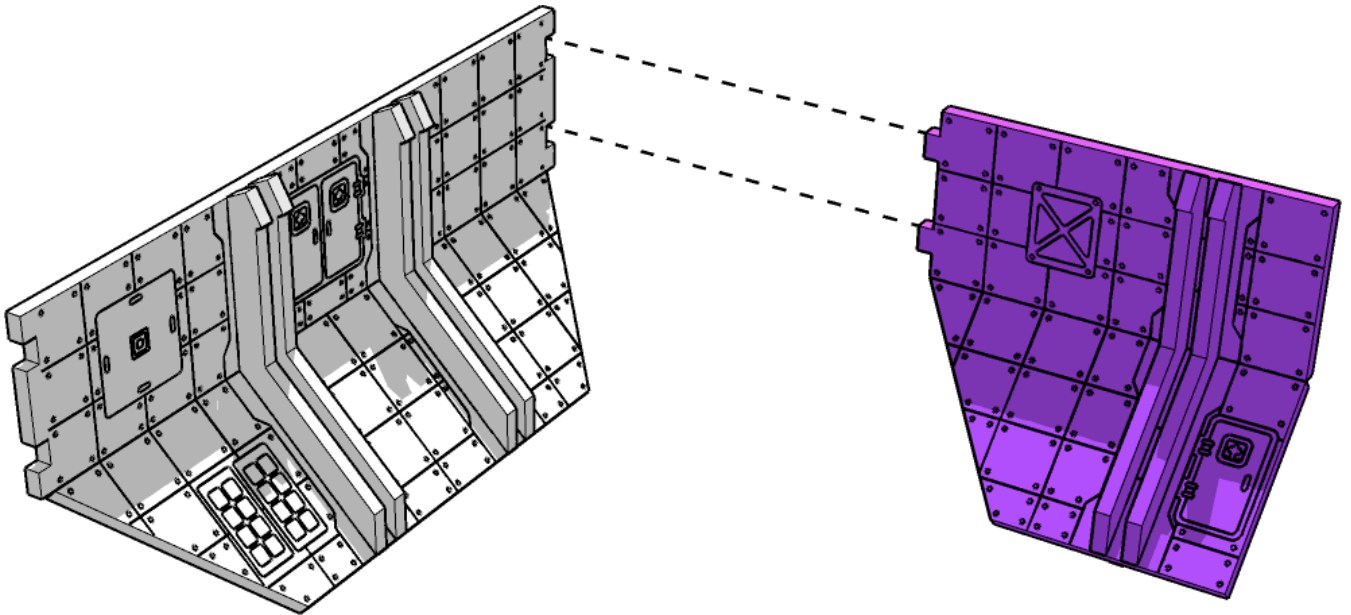



TABLETOP SCENICS

TTSCW-SFU-117
Mod.Co.N
Dead End Sections

19

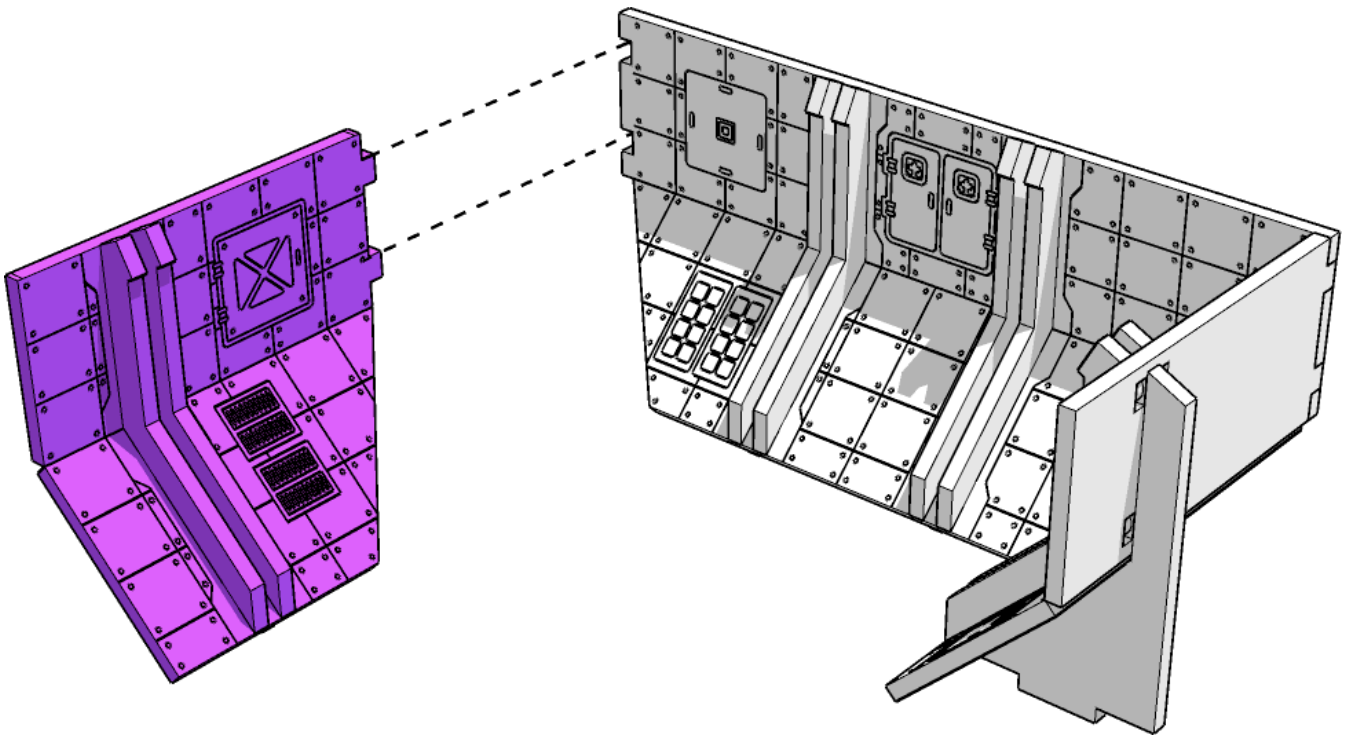



TABLETOP SCENICS

TTSCW-SFU-117
Mod.Co.N
Dead End Sections

20

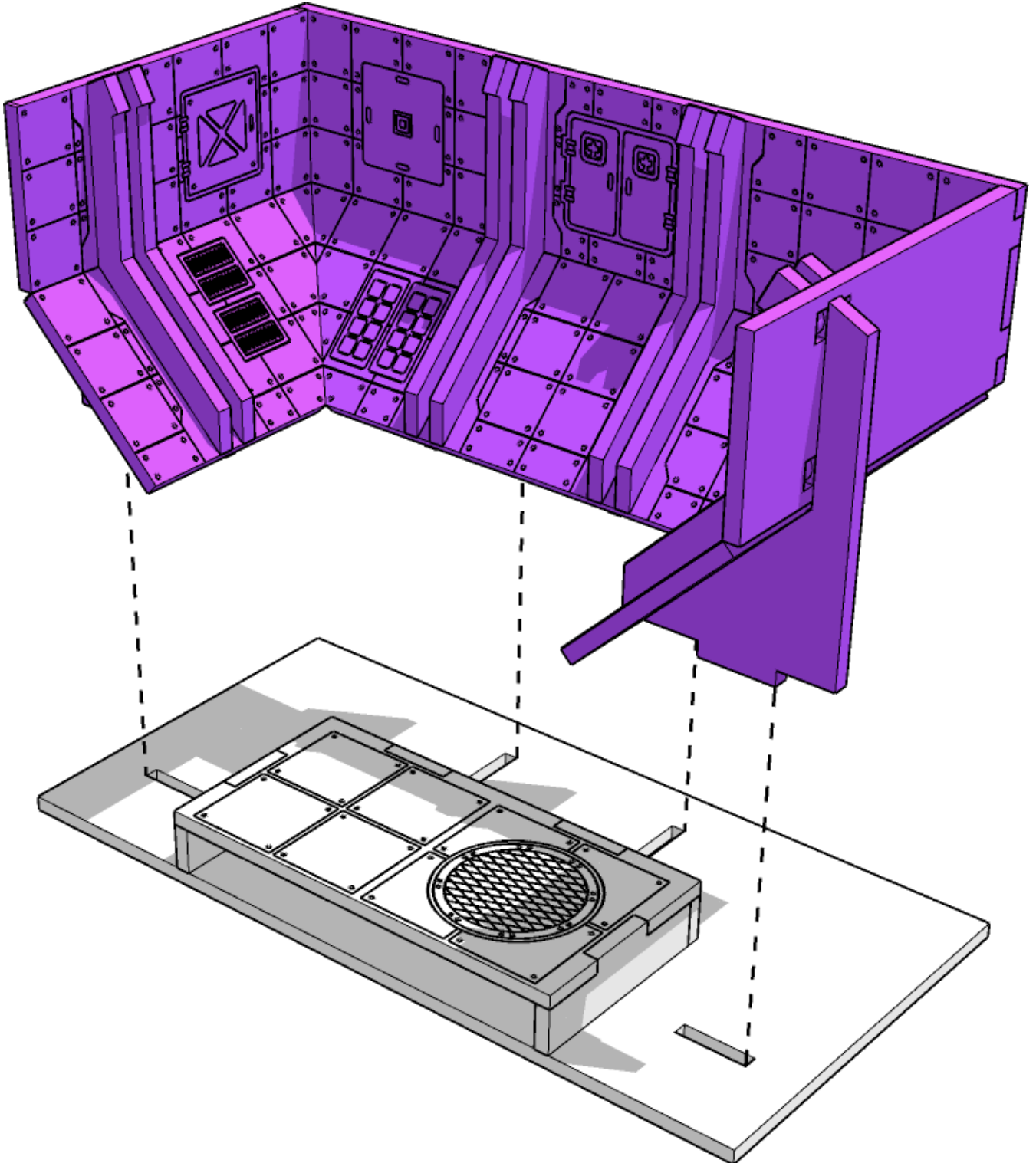



TABLETOP SCENICS

TTSCW-SFU-117
Mod.Co.N
Dead End Sections

21

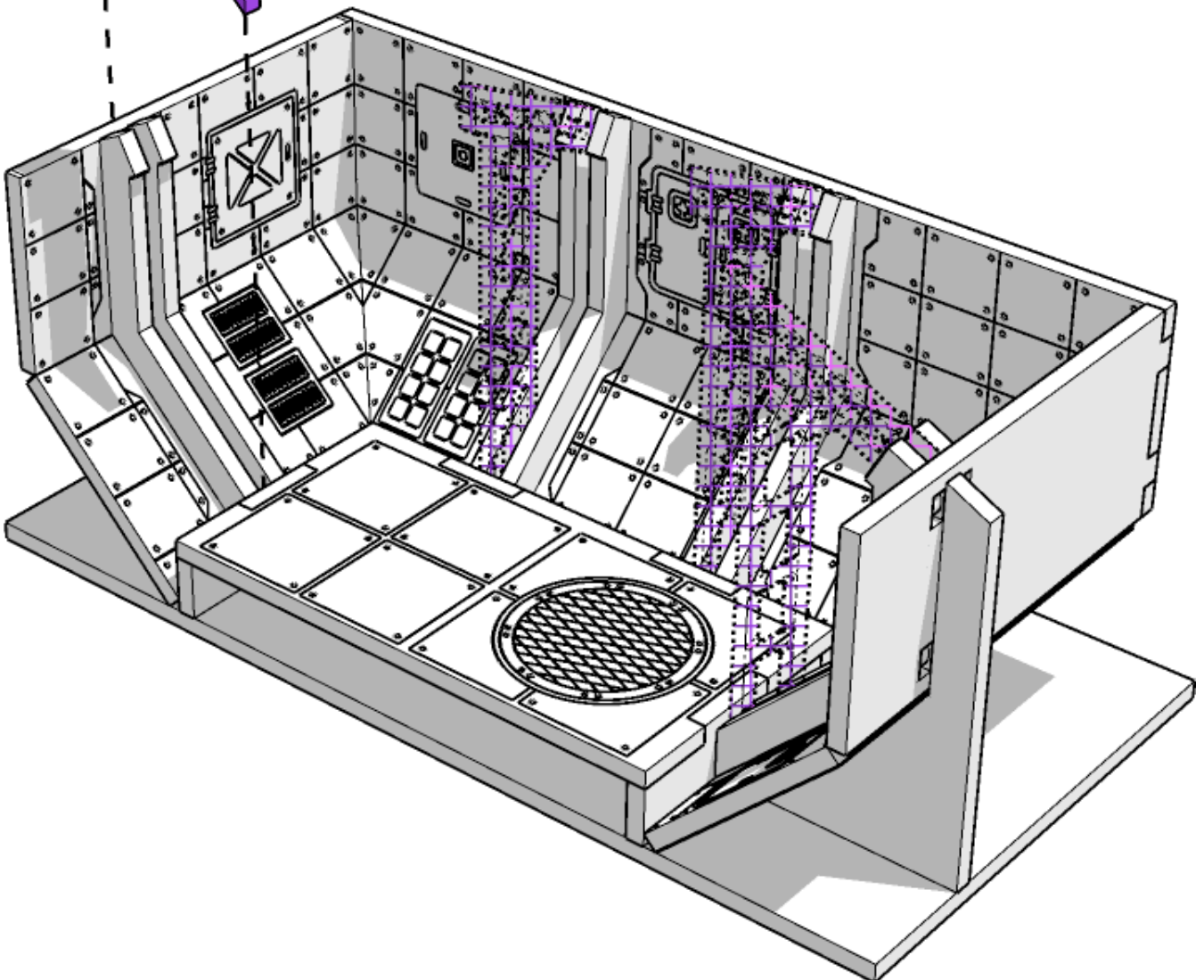
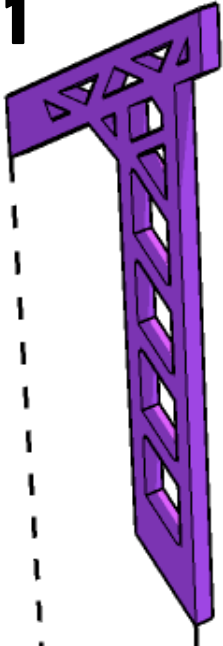



TABLETOP SCENICS

TTSCW-SFU-117
Mod.Co.N
Dead End Sections

22

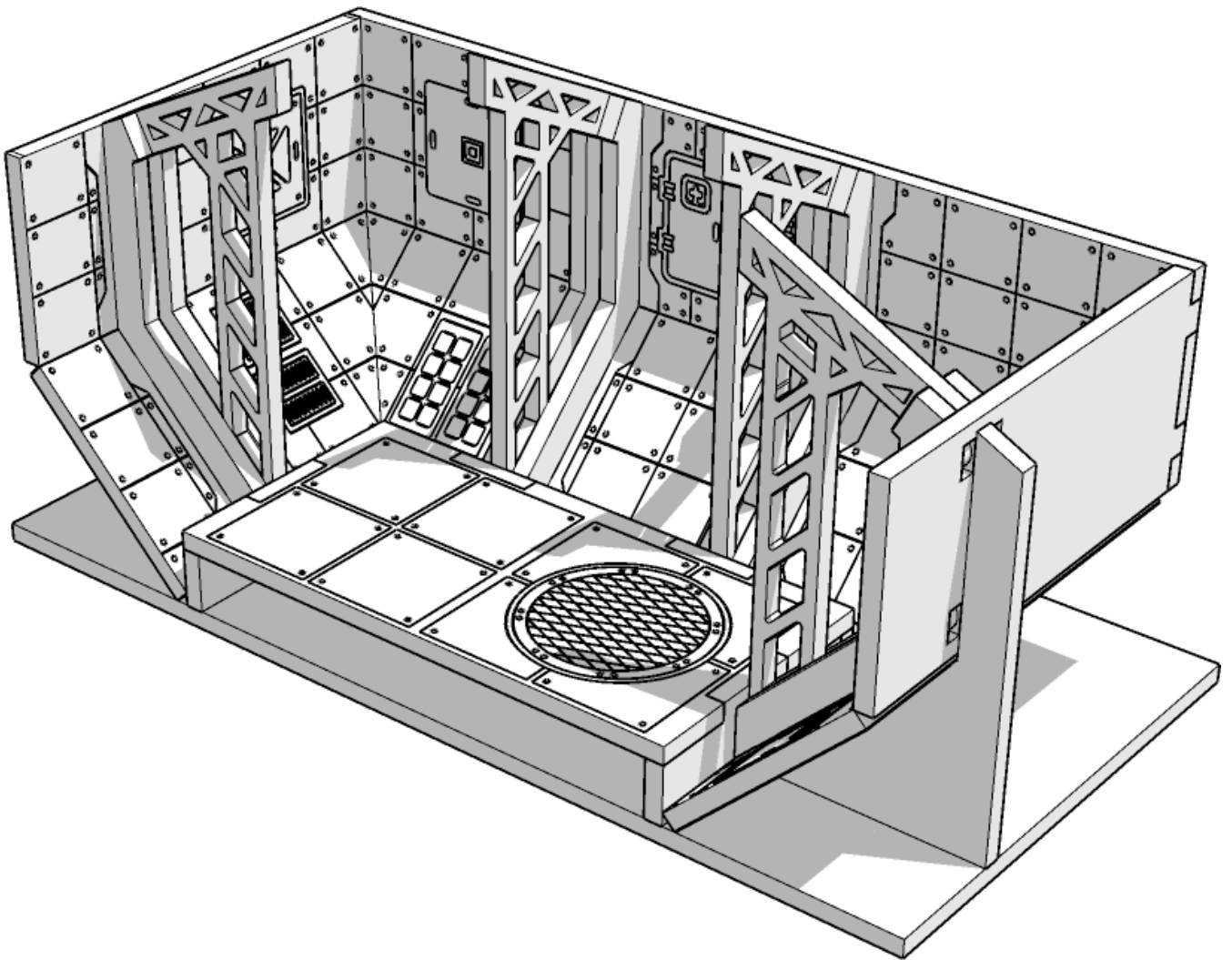

x2

 **TTCOMBAT**



TABLETOP SCENICS

TTSCW-SFU-117
Mod.Co.N
Dead End Sections

23

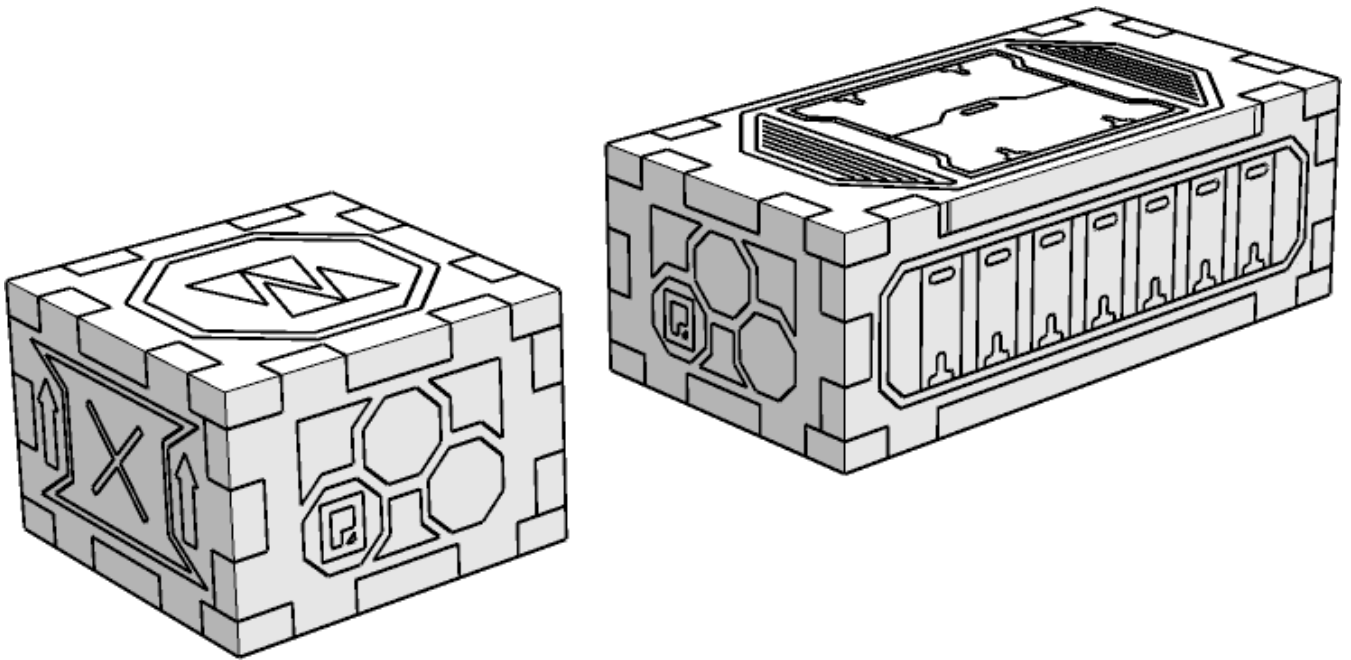



TABLETOP SCENICS

TTSCW-SFU-117
Mod.Co.N
Dead End Sections

24

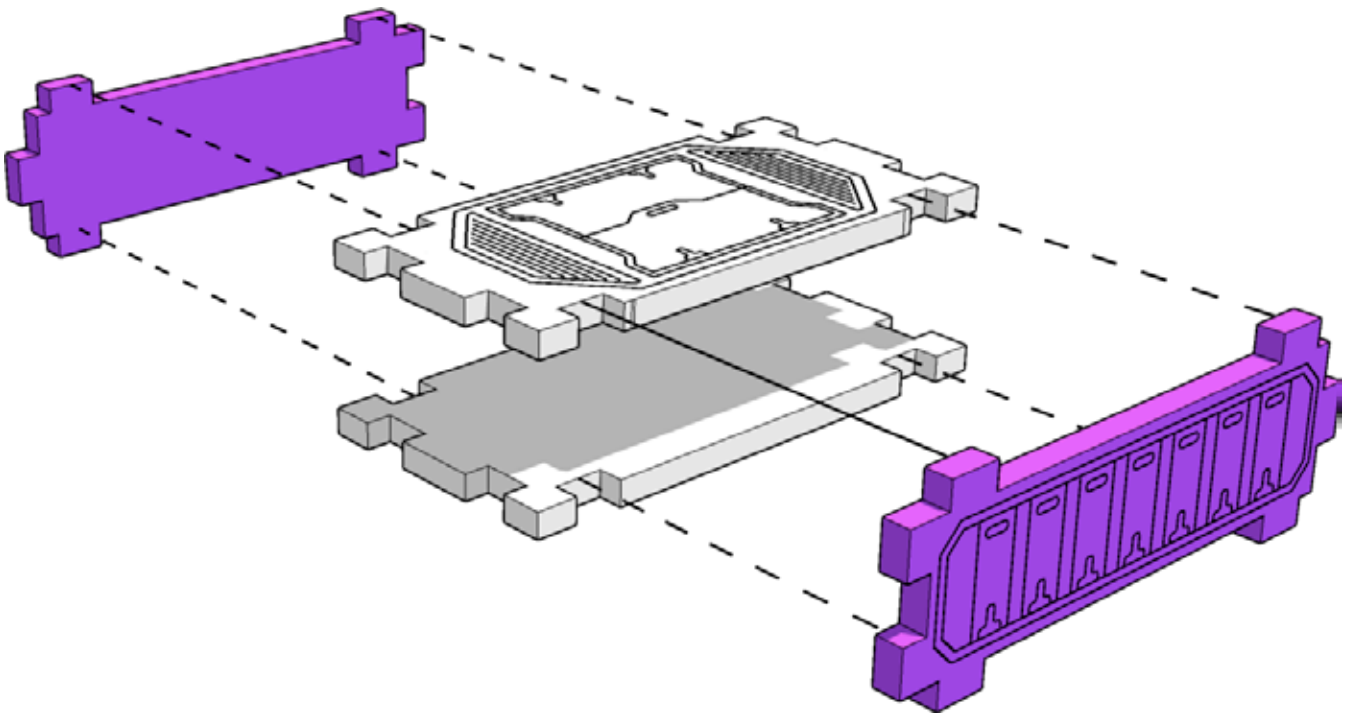



TABLETOP SCENICS

TTSCW-SFU-117
Mod.Co.N
Dead End Sections

25

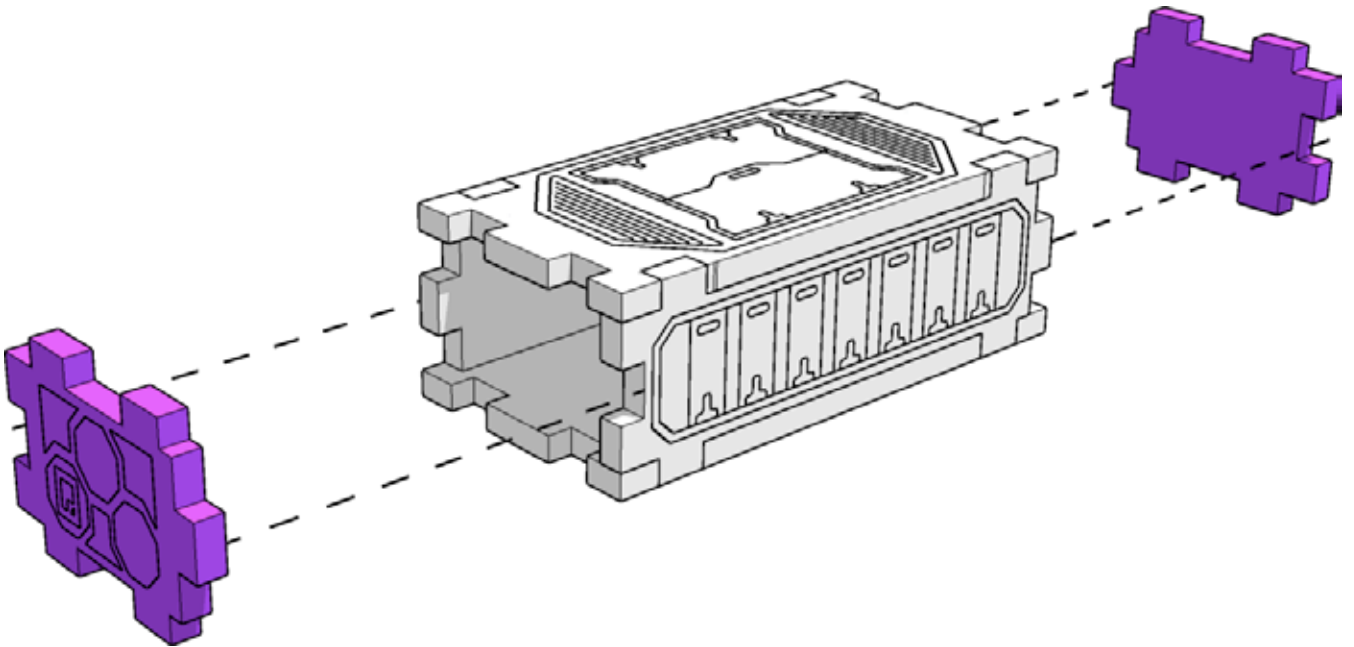



TABLETOP SCENICS

TTSCW-SFU-117
Mod.Co.N
Dead End Sections

26

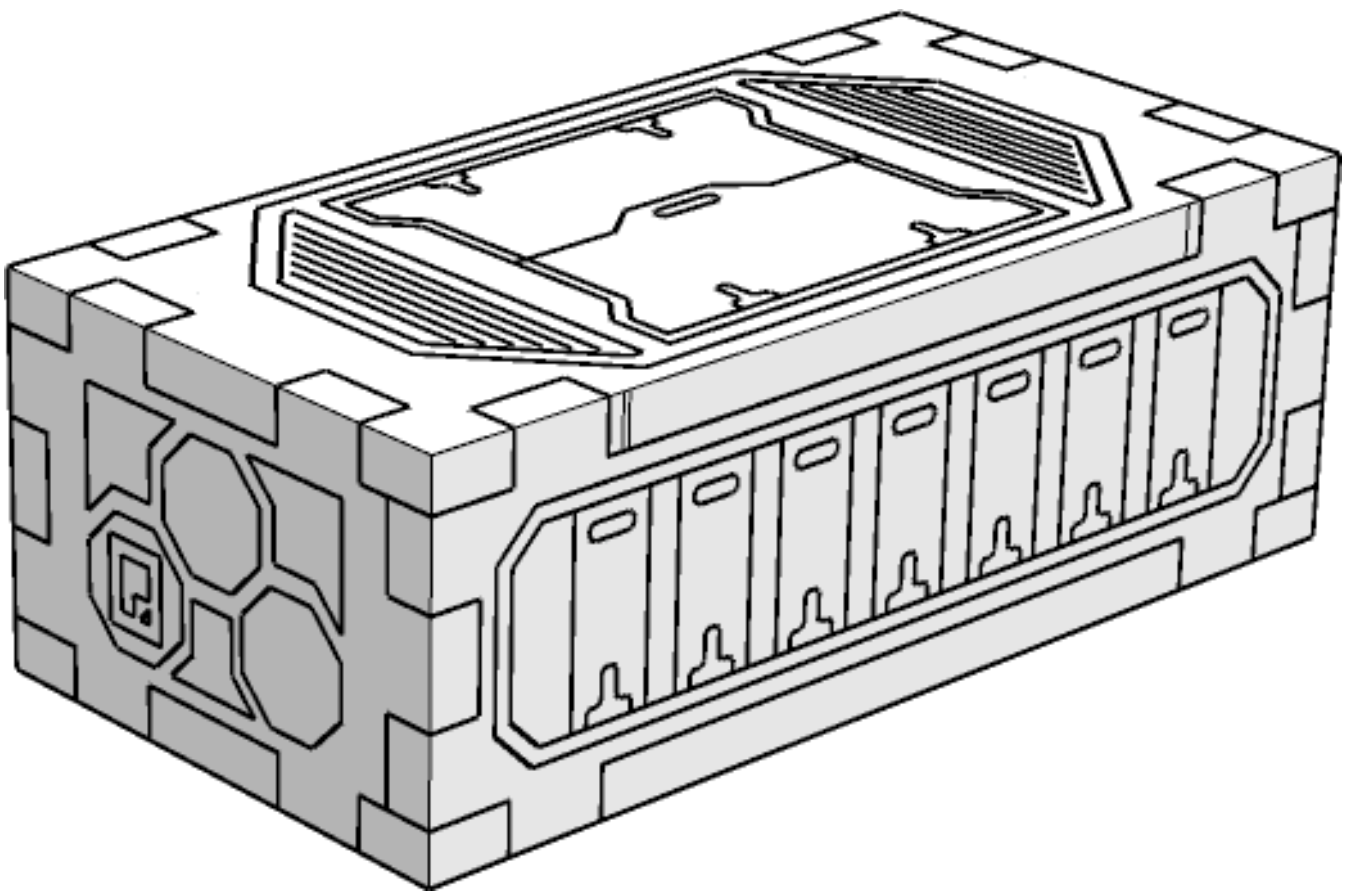

x2



TABLETOP SCENICS

TTSCW-SFU-117
Mod.Co.N
Dead End Sections

27

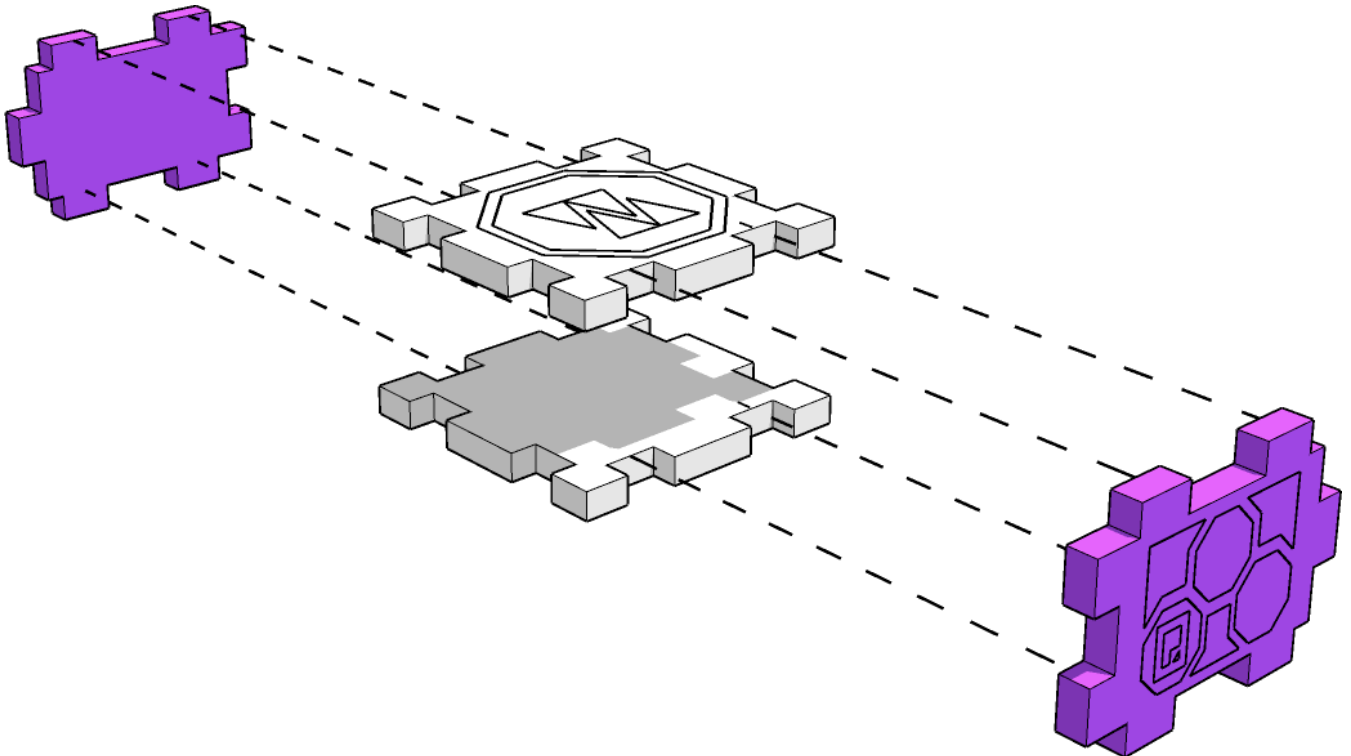



TABLETOP SCENICS

TTSCW-SFU-117
Mod.Co.N
Dead End Sections

28

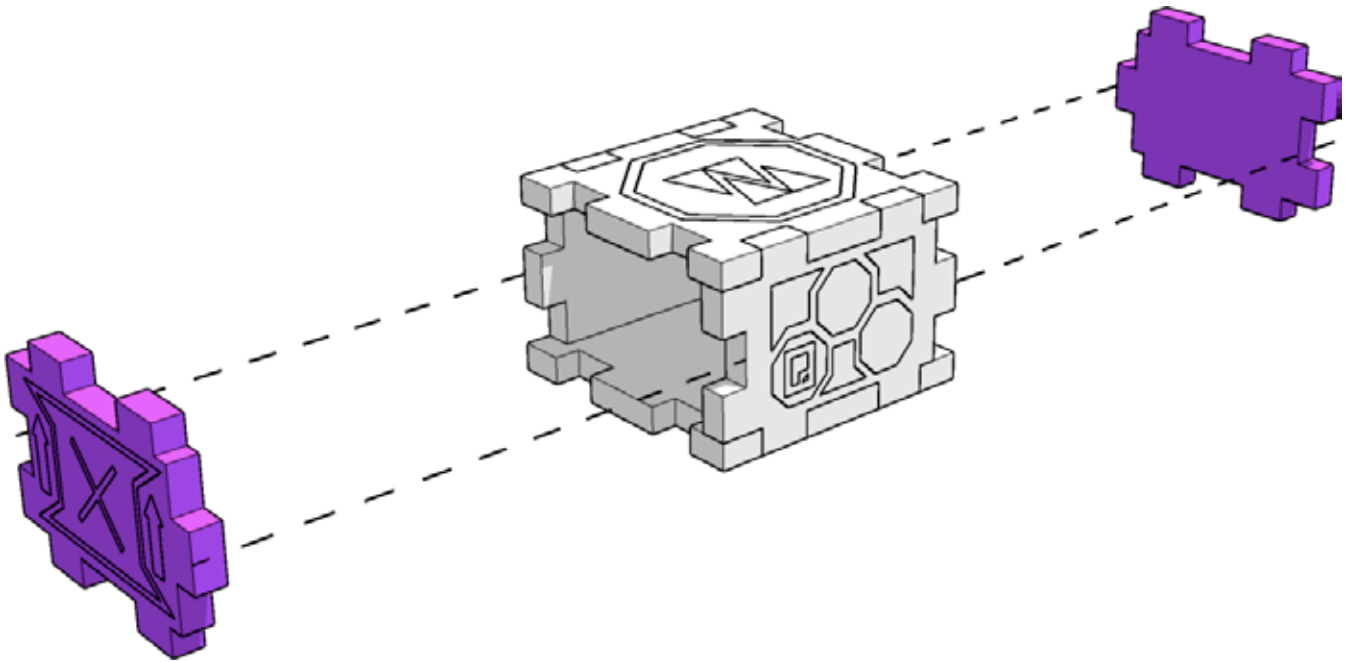



TABLETOP SCENICS

TTSCW-SFU-117
Mod.Co.N
Dead End Sections

29

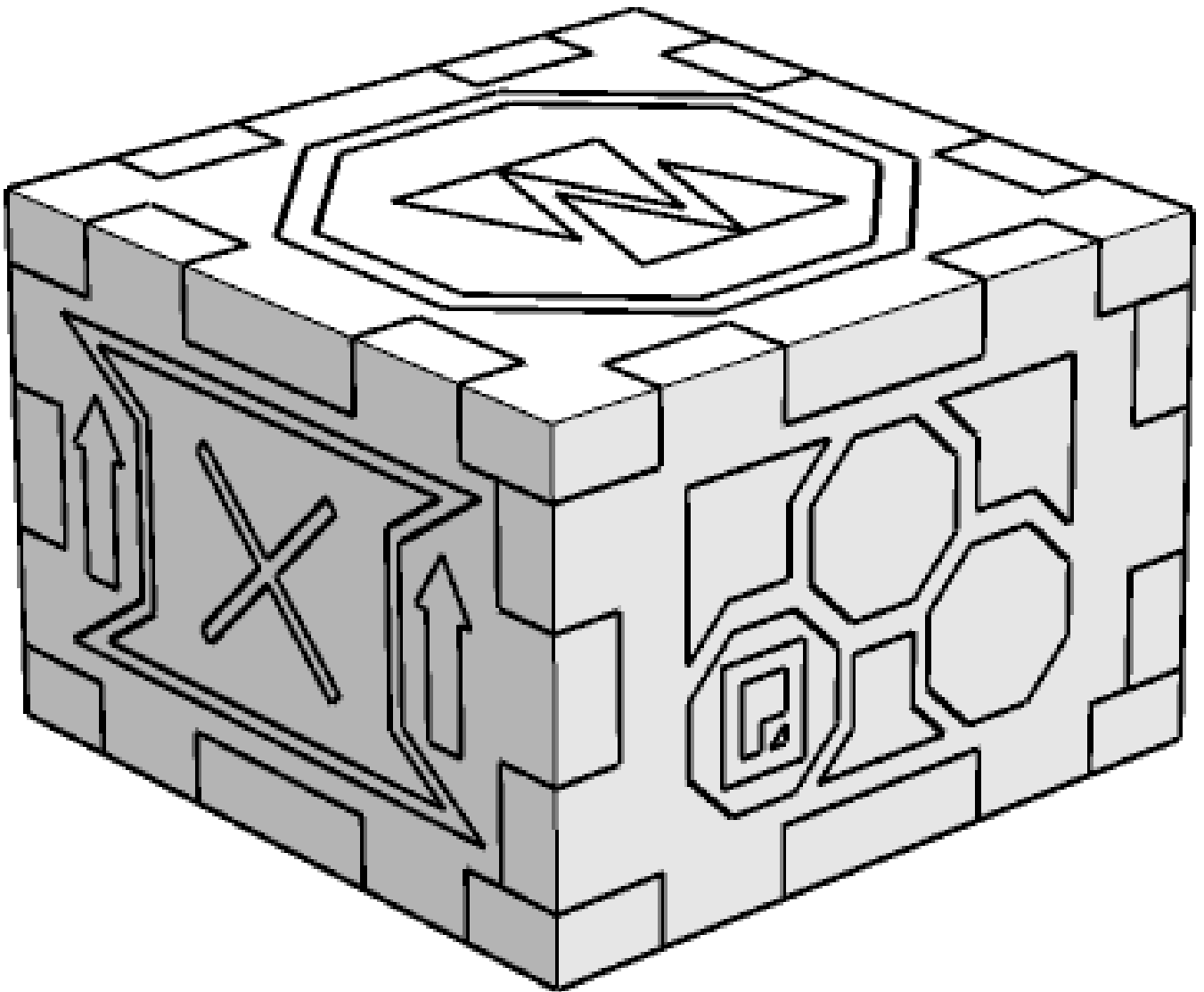

x2



TABLETOP SCENICS

30

TTSCW-SFU-117
Mod.Co.N
Dead End Sections

