

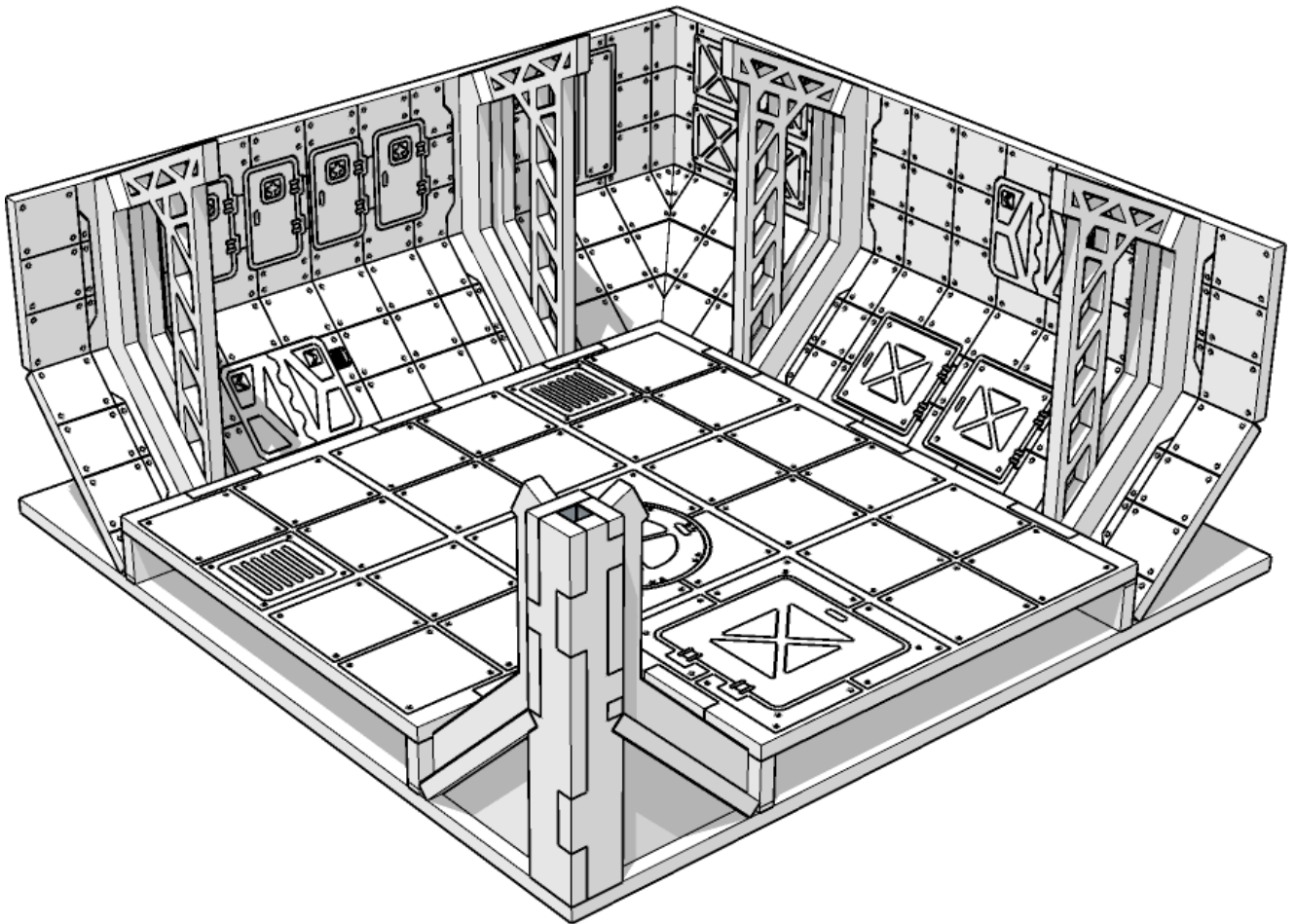

**TABLETOP
SCENICS**

**TTSCW-SFU-115
Mod.Co.N
Corner Junction**



 **TTCOMBAT**



TABLETOP SCENICS

TTSCW-SFU-115
Mod.Co.N
Corner Junction

2

These are a series of icons that may be used throughout the instructions to help your assembly.
If in doubt, scroll ahead to confirm.



Do not glue this part



Carefully score and
fold this part

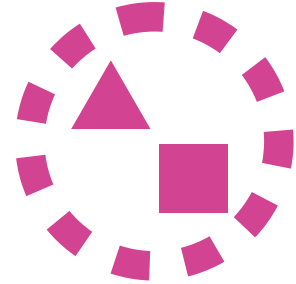

This part - or its placement is
completely optional

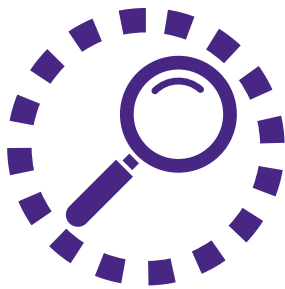

Look closely at this step -
The process order or part
used, may be specific



Repeat making this part
the specified number
of times

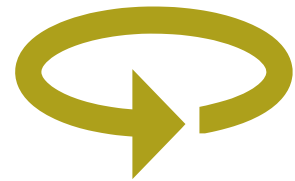

The next instruction step
will be the same assembly
so far, but from a different
angle

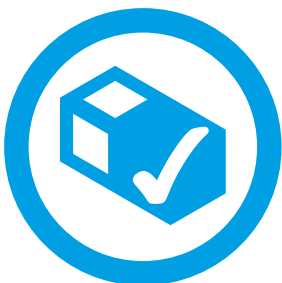

Sub-assembly complete.
This smaller construction
is ready to add to the
main kit



Assembly Complete! There
could be more optional
parts - check to the very end
of instructions



FRAGILE: DO NOT BEND.
“Bendy wood” is designed to
curve around a designed
frame only.



TABLETOP SCENICS

TTSCW-SFU-115
Mod.Co.N
Corner Junction

3

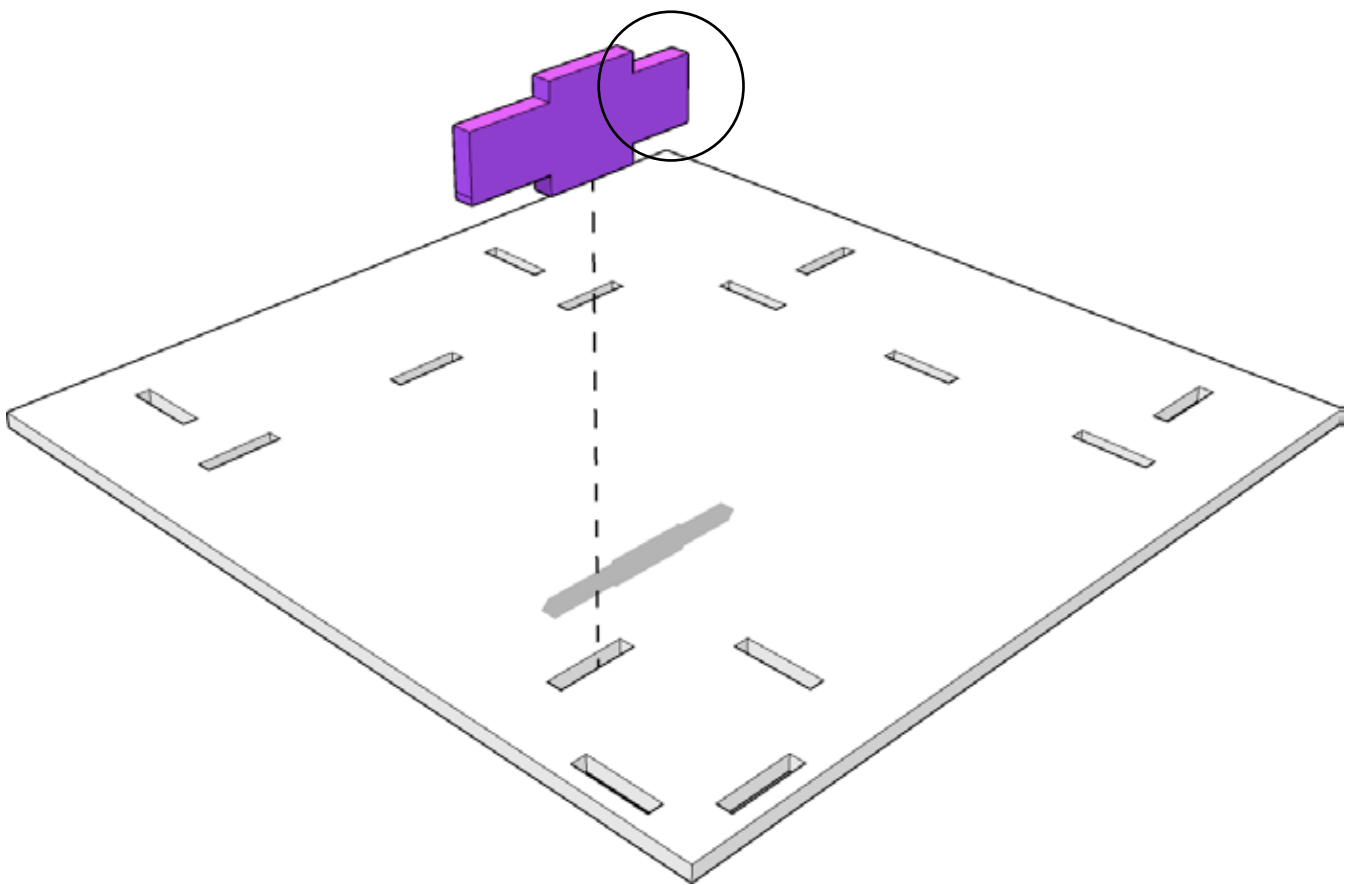

There are two similar parts. The circled section of the highlighted piece is shorter on one side and is the required piece



 **TTCOMBAT**



TABLETOP SCENICS

TTSCW-SFU-115
Mod.Co.N
Corner Junction

4

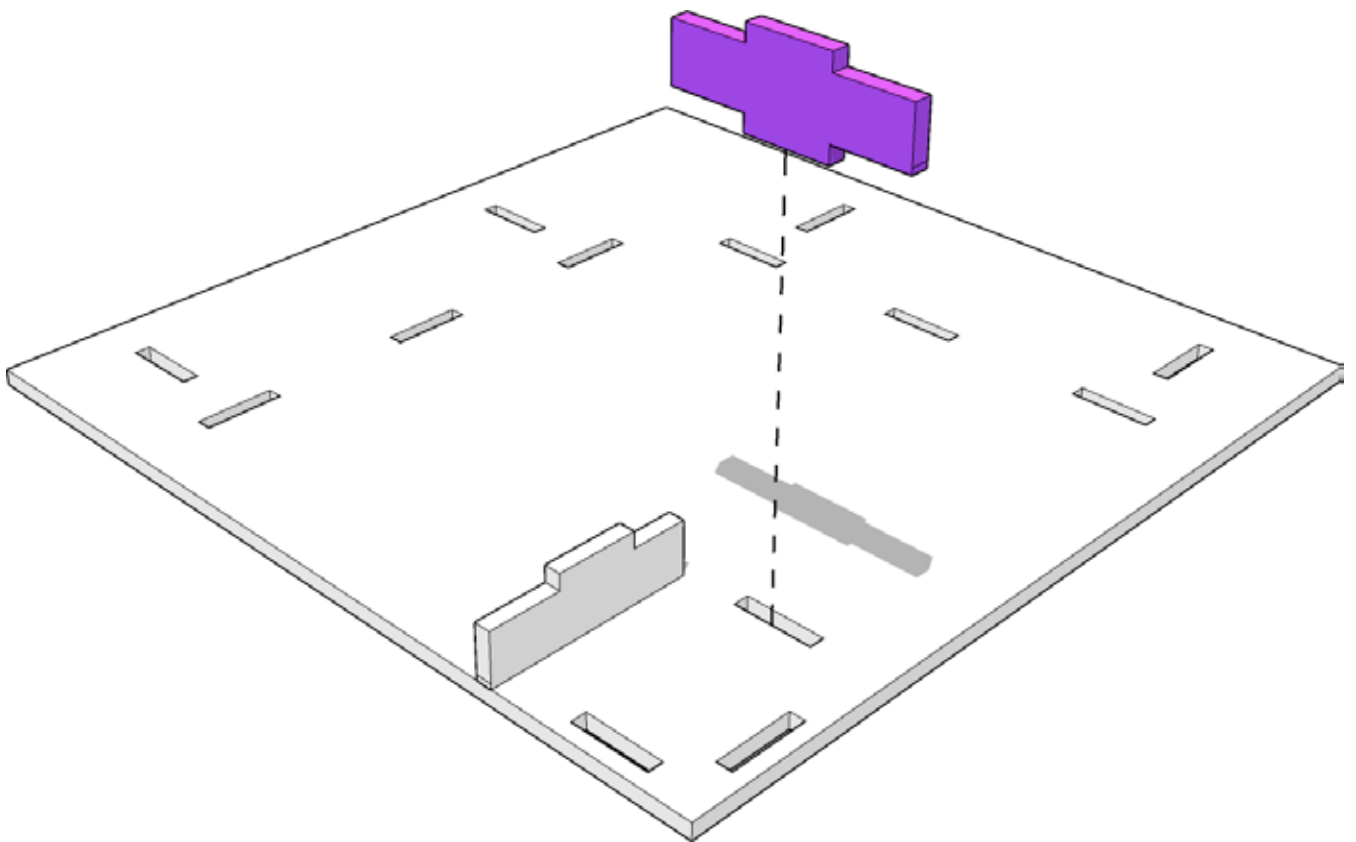



TABLETOP SCENICS

TTSCW-SFU-115
Mod.Co.N
Corner Junction

5

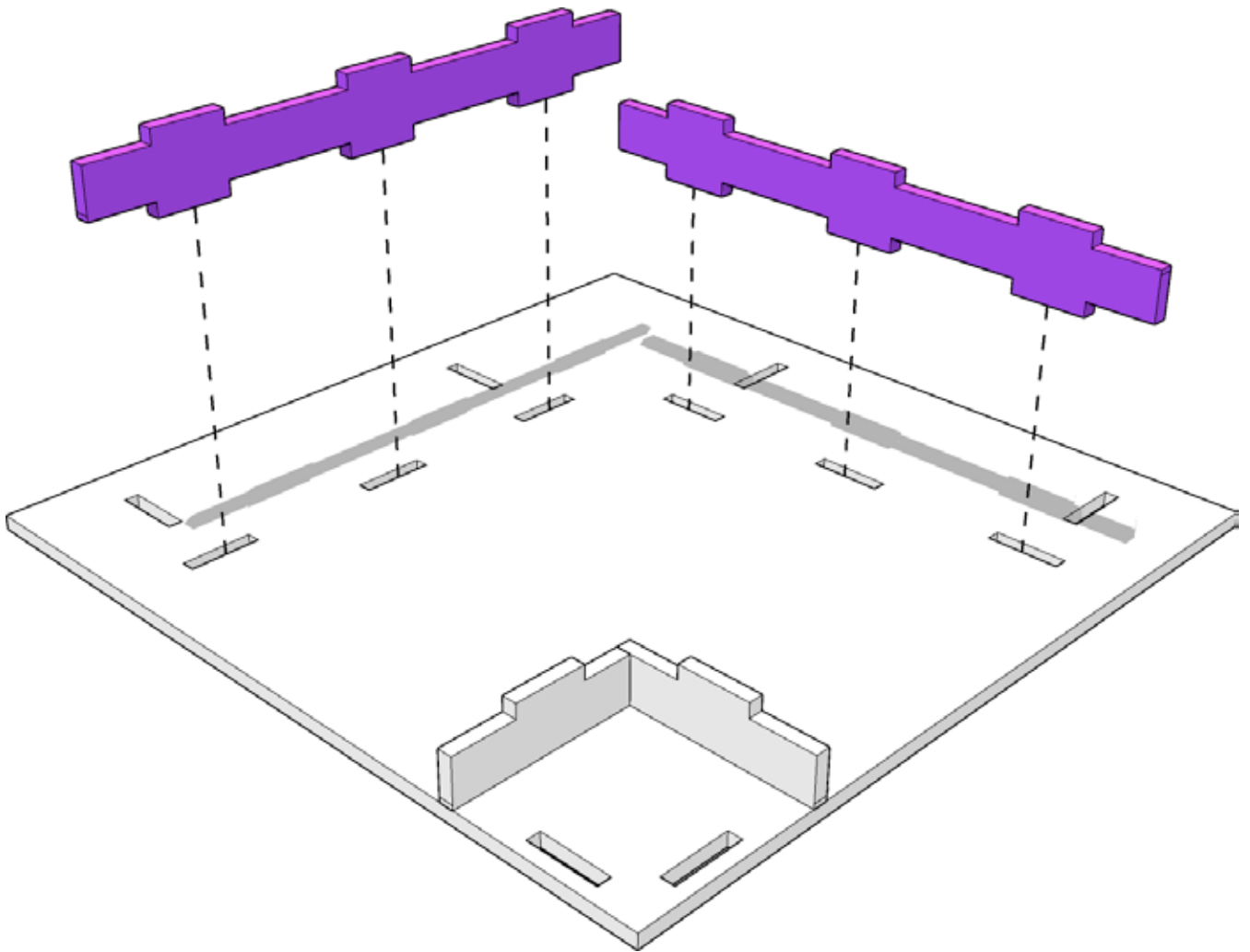



TABLETOP SCENICS

TTSCW-SFU-115
Mod.Co.N
Corner Junction

6

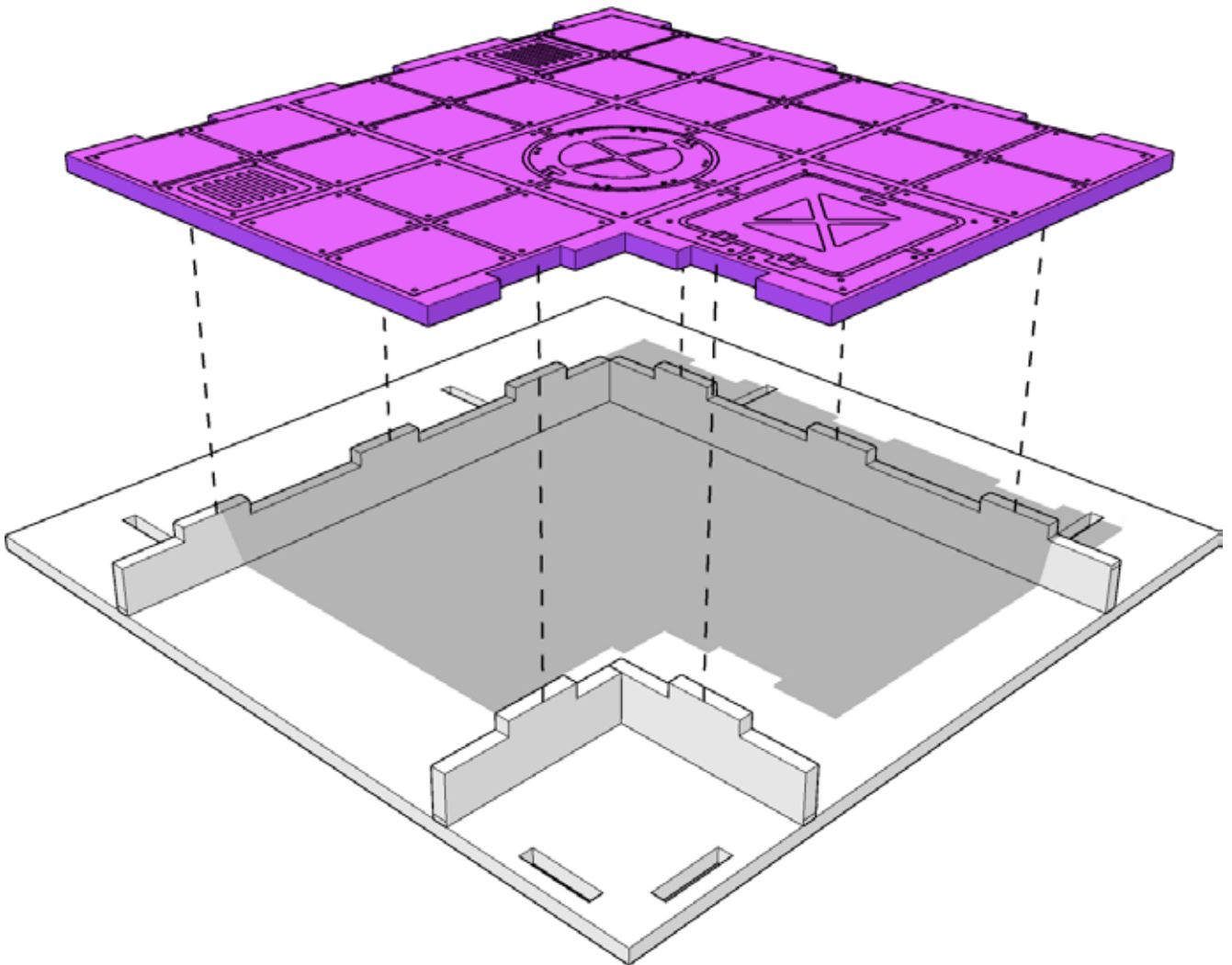



TABLETOP SCENICS

TTSCW-SFU-115
Mod.Co.N
Corner Junction

7

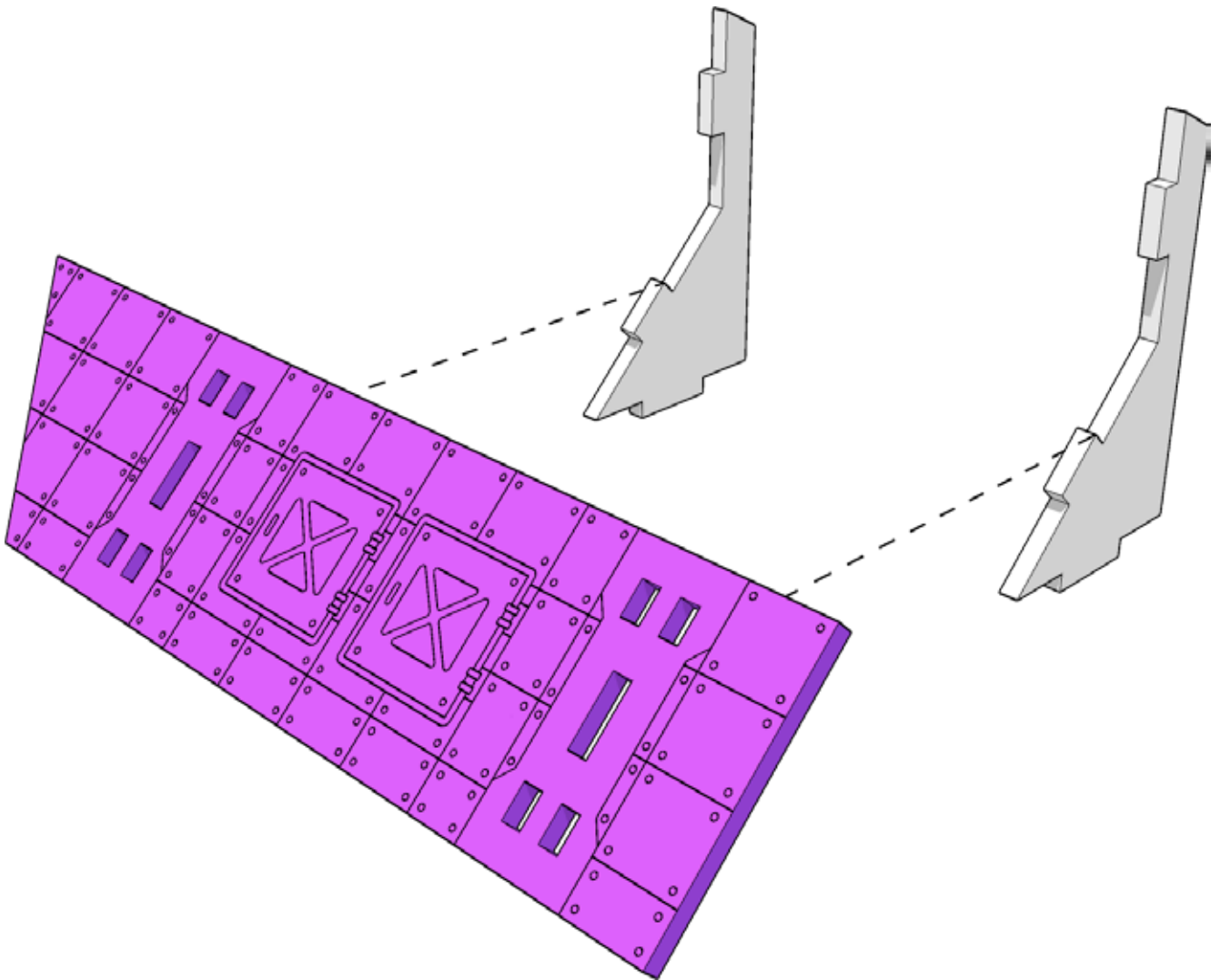



TABLETOP SCENICS

TTSCW-SFU-115
Mod.Co.N
Corner Junction

8

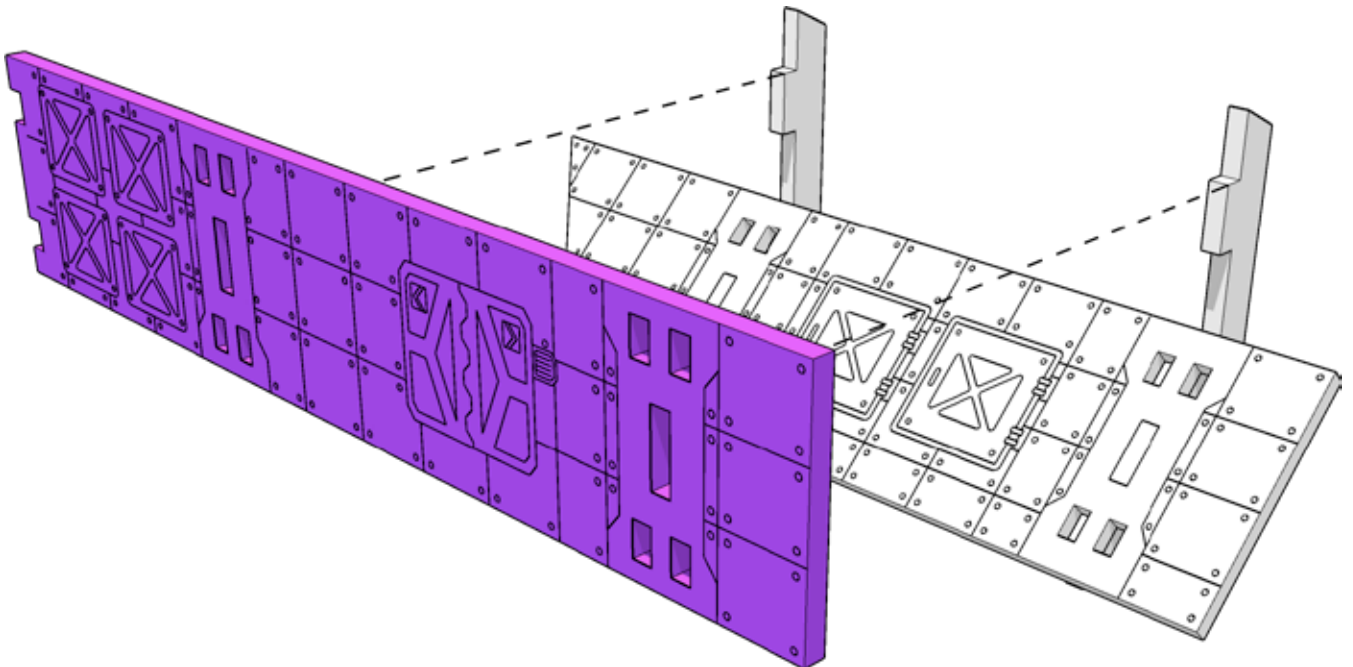



TABLETOP SCENICS

TTSCW-SFU-115
Mod.Co.N
Corner Junction

9

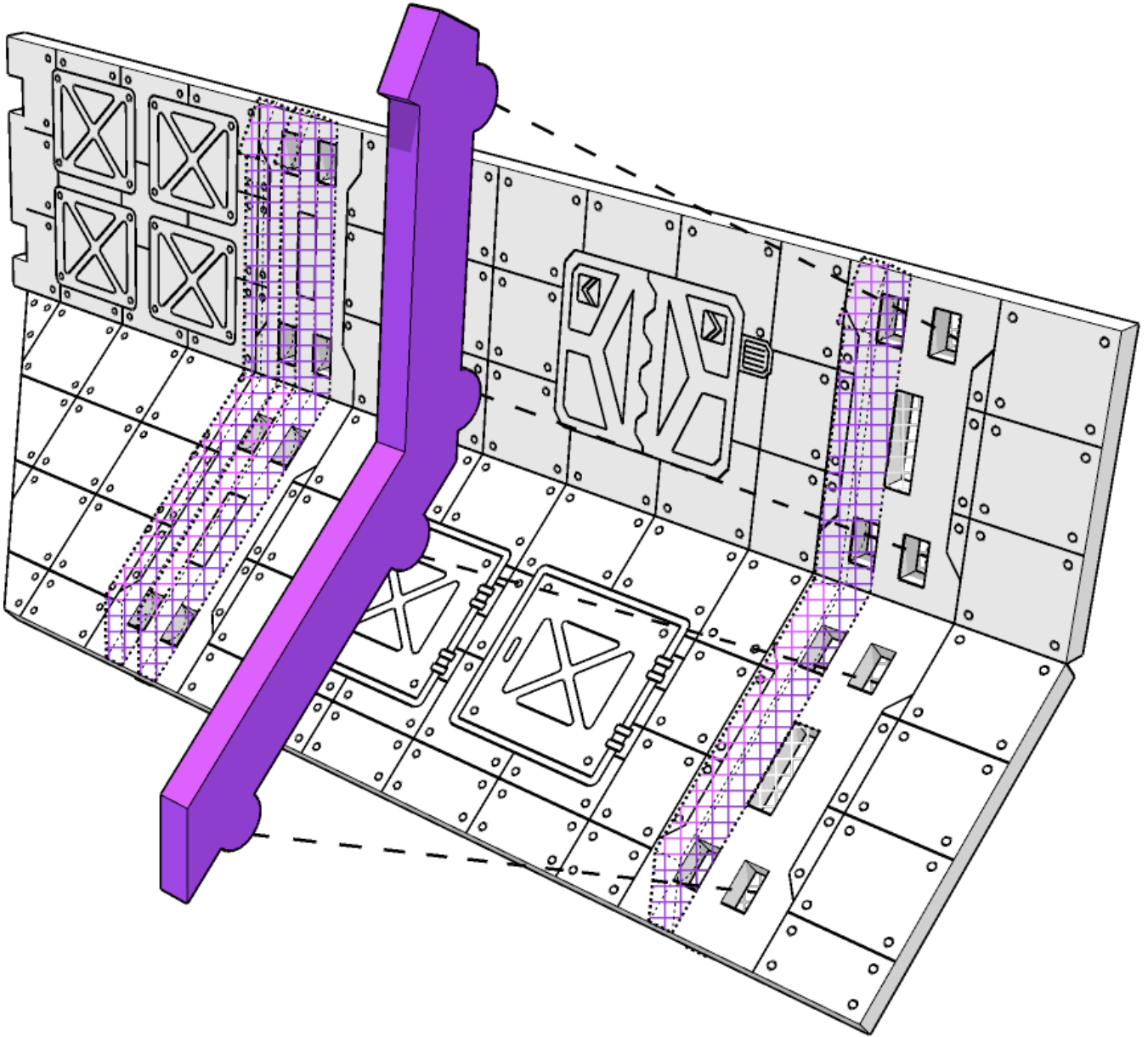



TABLETOP SCENICS

TTSCW-SFU-115
Mod.Co.N
Corner Junction

10

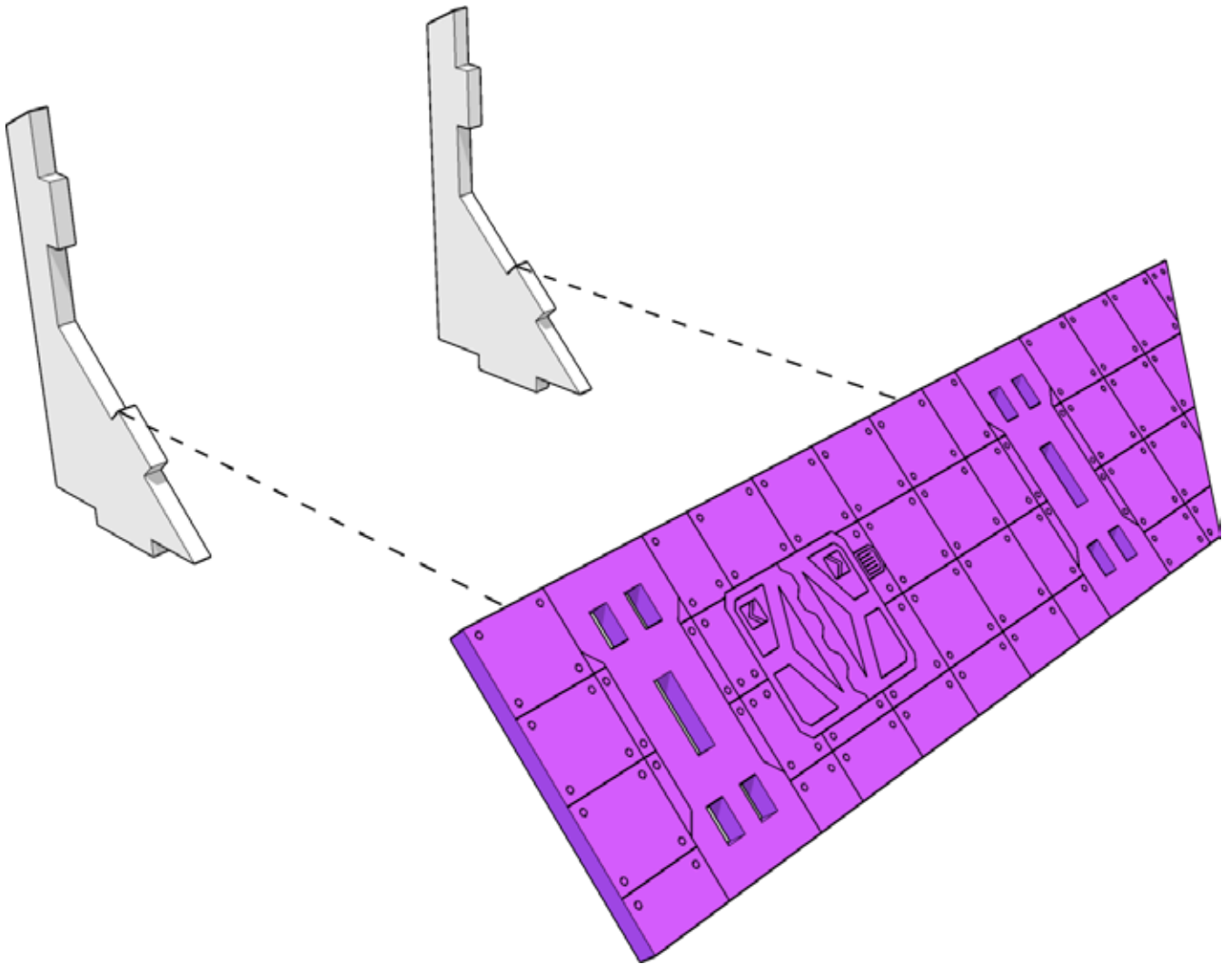



TABLETOP SCENICS

TTSCW-SFU-115
Mod.Co.N
Corner Junction

11

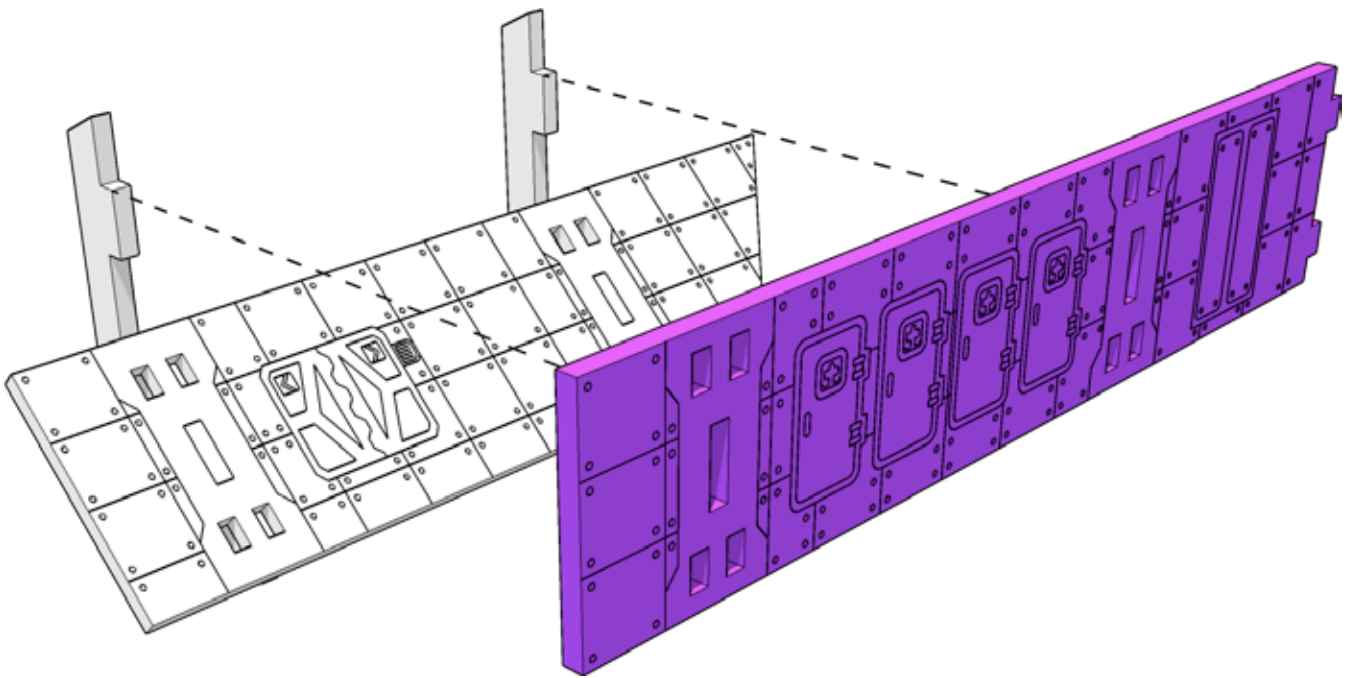



TABLETOP SCENICS

TTSCW-SFU-115
Mod.Co.N
Corner Junction

12

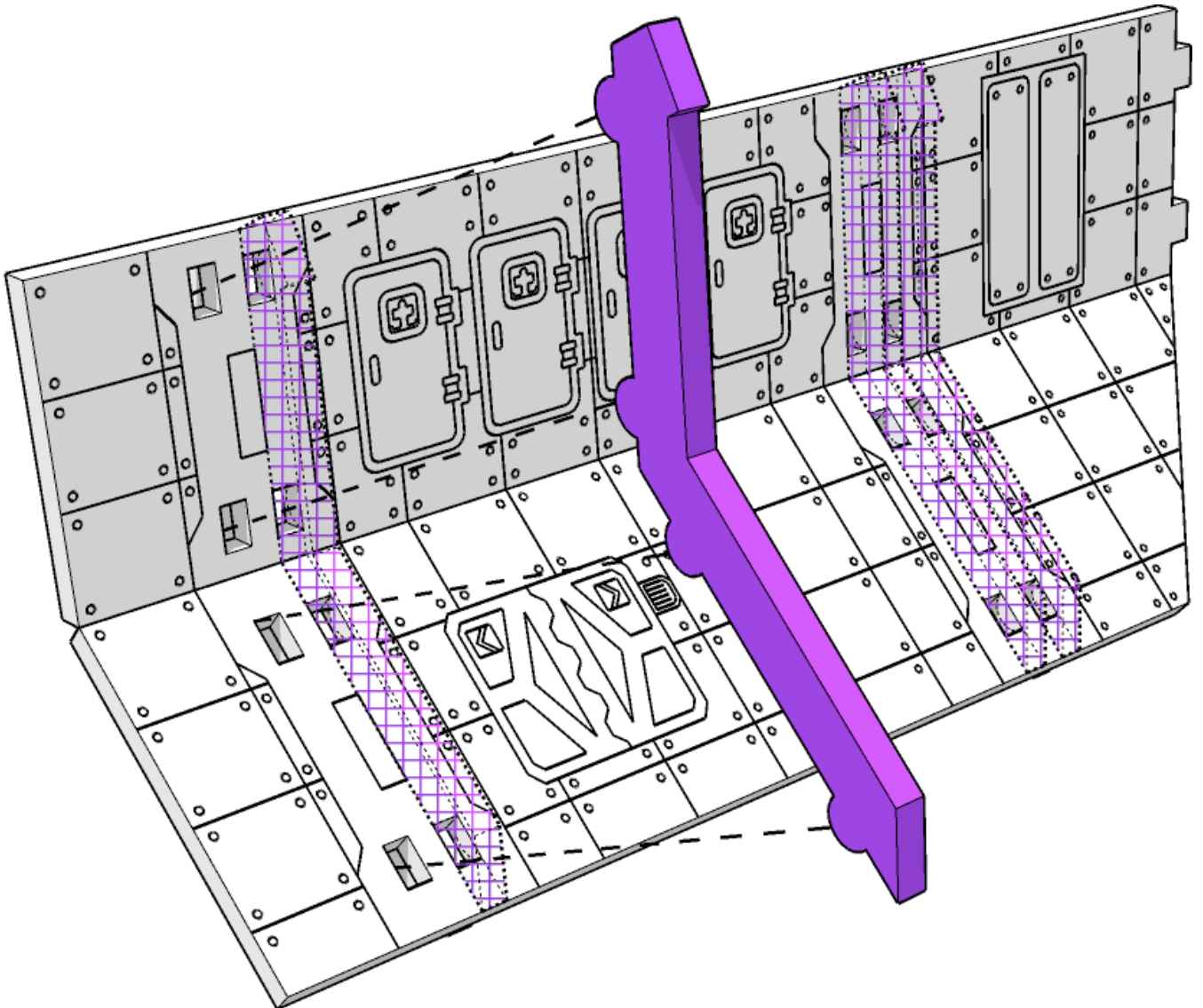



TABLETOP SCENICS

TTSCW-SFU-115
Mod.Co.N
Corner Junction

13

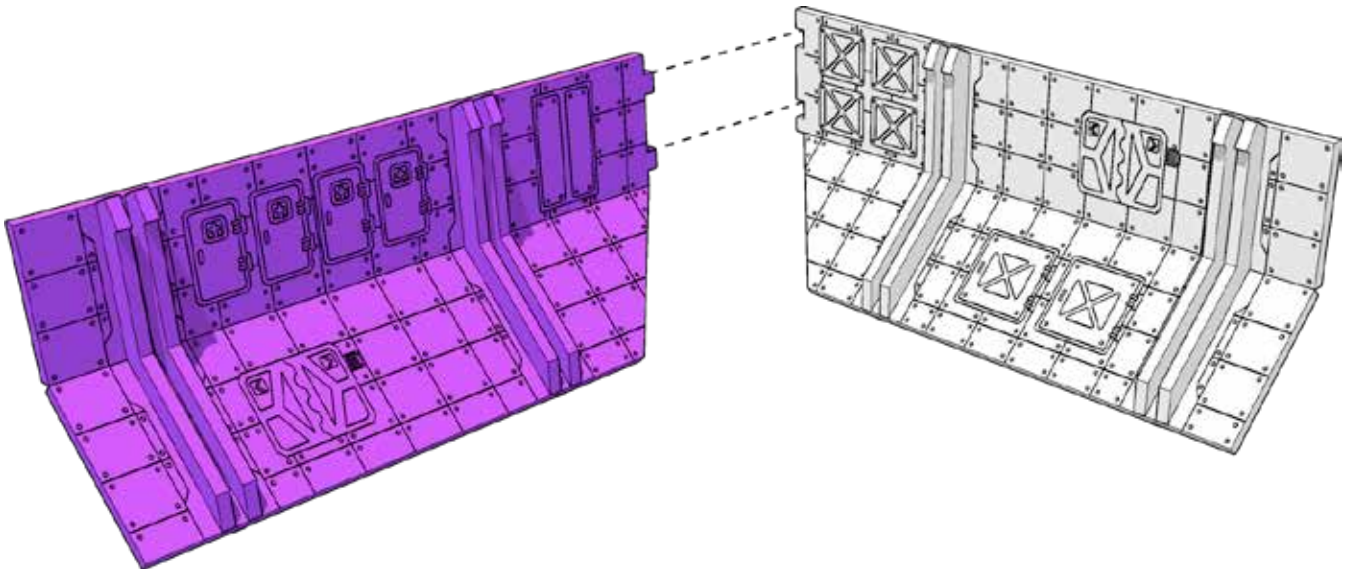



TABLETOP SCENICS

TTSCW-SFU-115
Mod.Co.N
Corner Junction

14

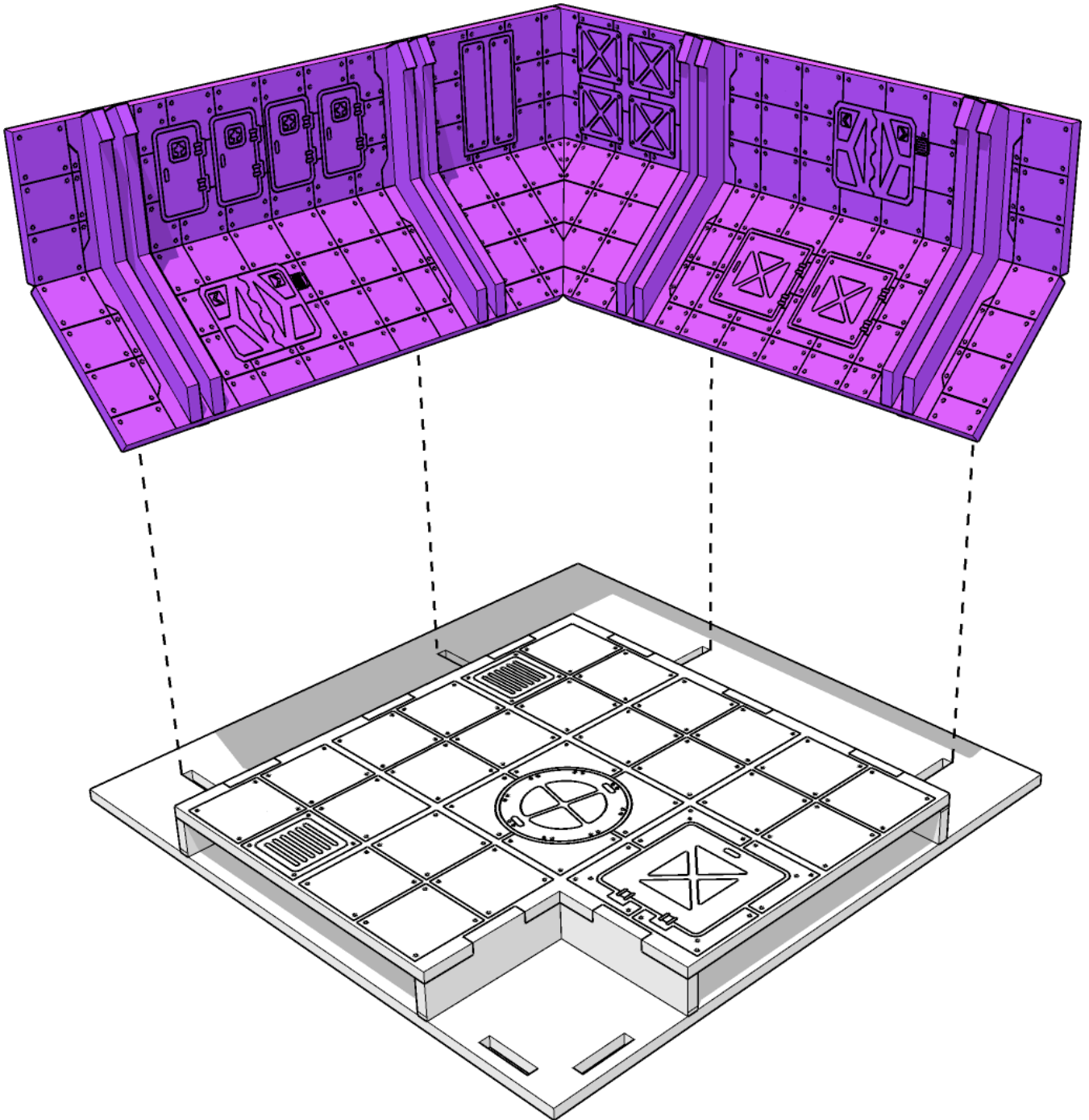



TABLETOP SCENICS

TTSCW-SFU-115
Mod.Co.N
Corner Junction

15

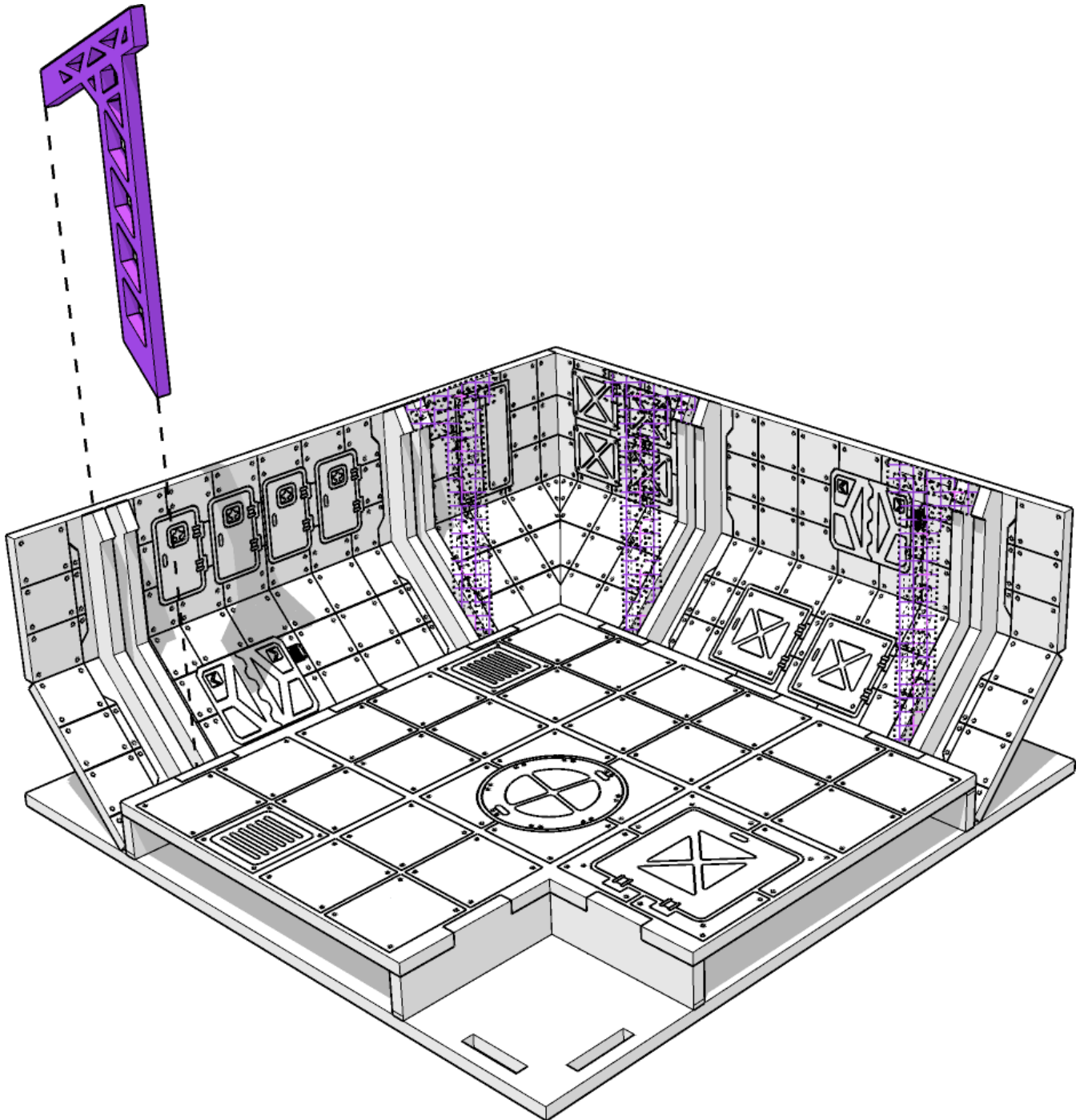



TABLETOP SCENICS

TTSCW-SFU-115
Mod.Co.N
Corner Junction

16

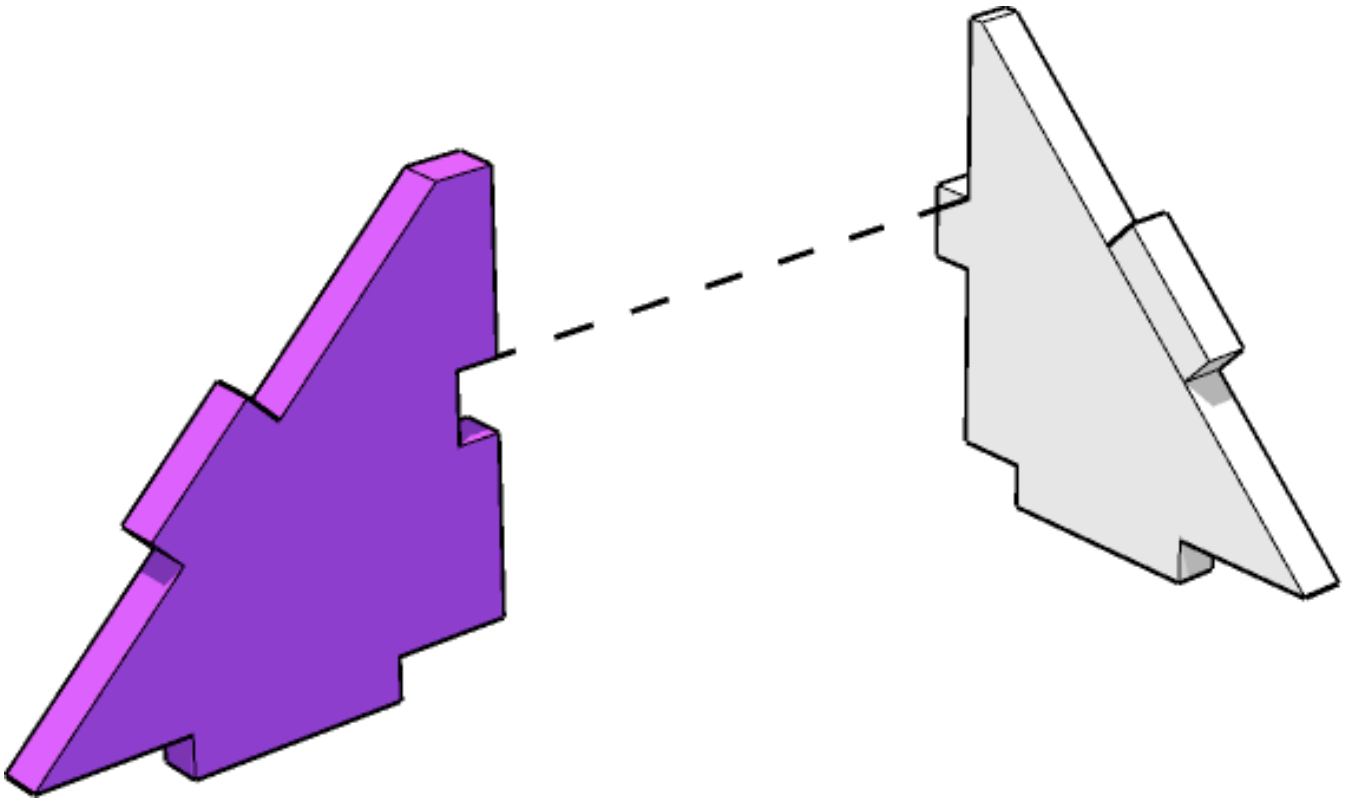



TABLETOP SCENICS

TTSCW-SFU-115
Mod.Co.N
Corner Junction

17

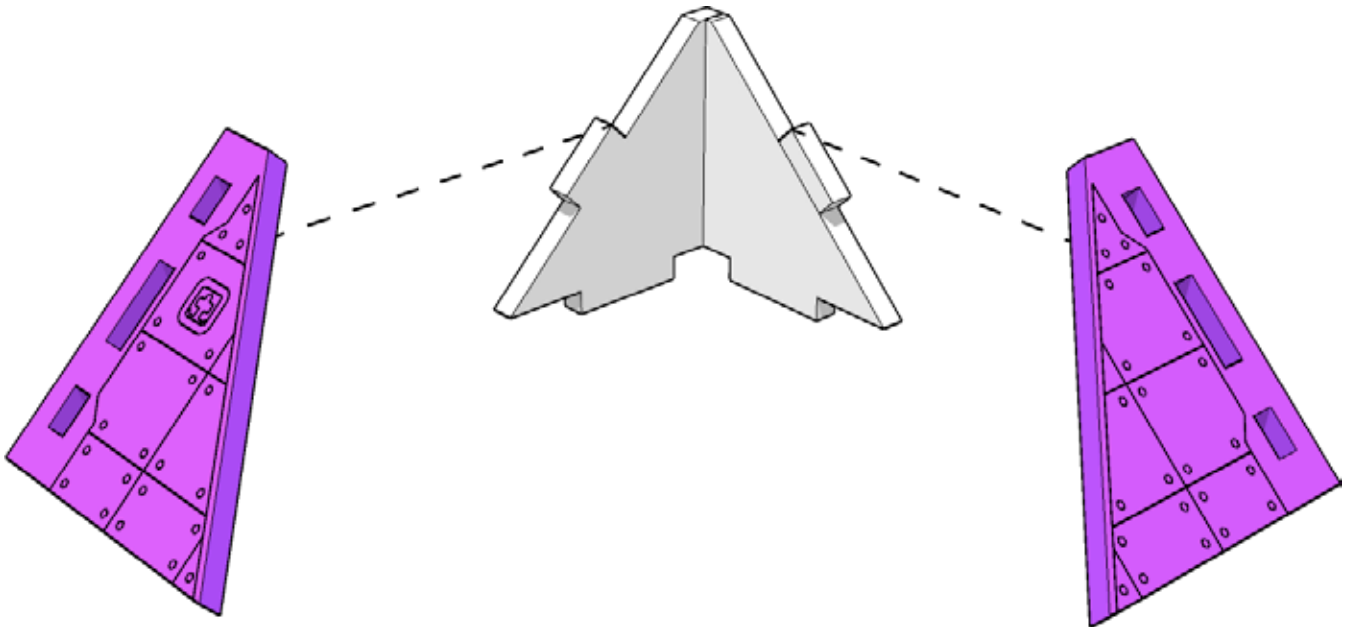



TABLETOP SCENICS

TTSCW-SFU-115
Mod.Co.N
Corner Junction

18

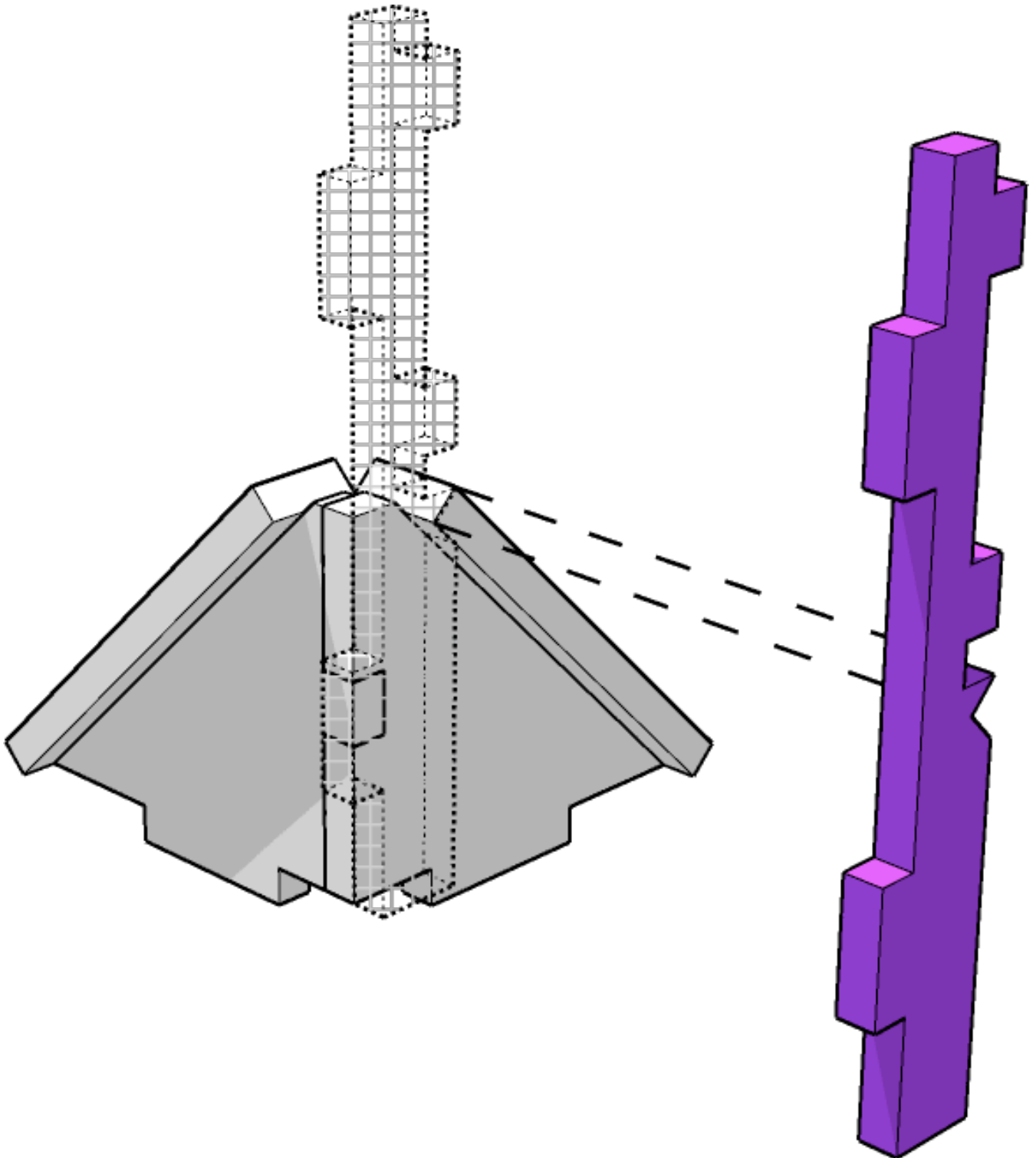



TABLETOP SCENICS

TTSCW-SFU-115
Mod.Co.N
Corner Junction

19

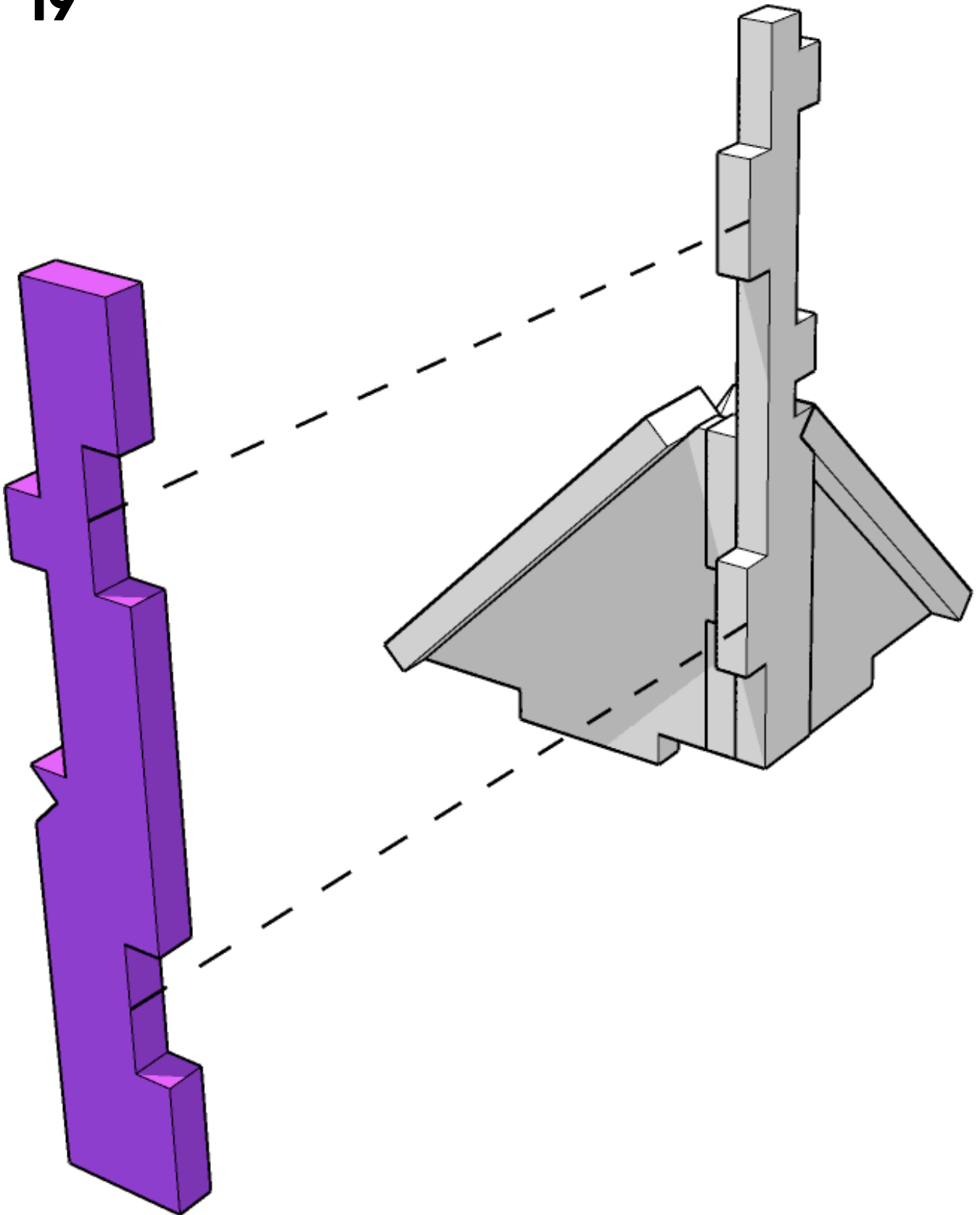



TABLETOP SCENICS

TTSCW-SFU-115
Mod.Co.N
Corner Junction

20

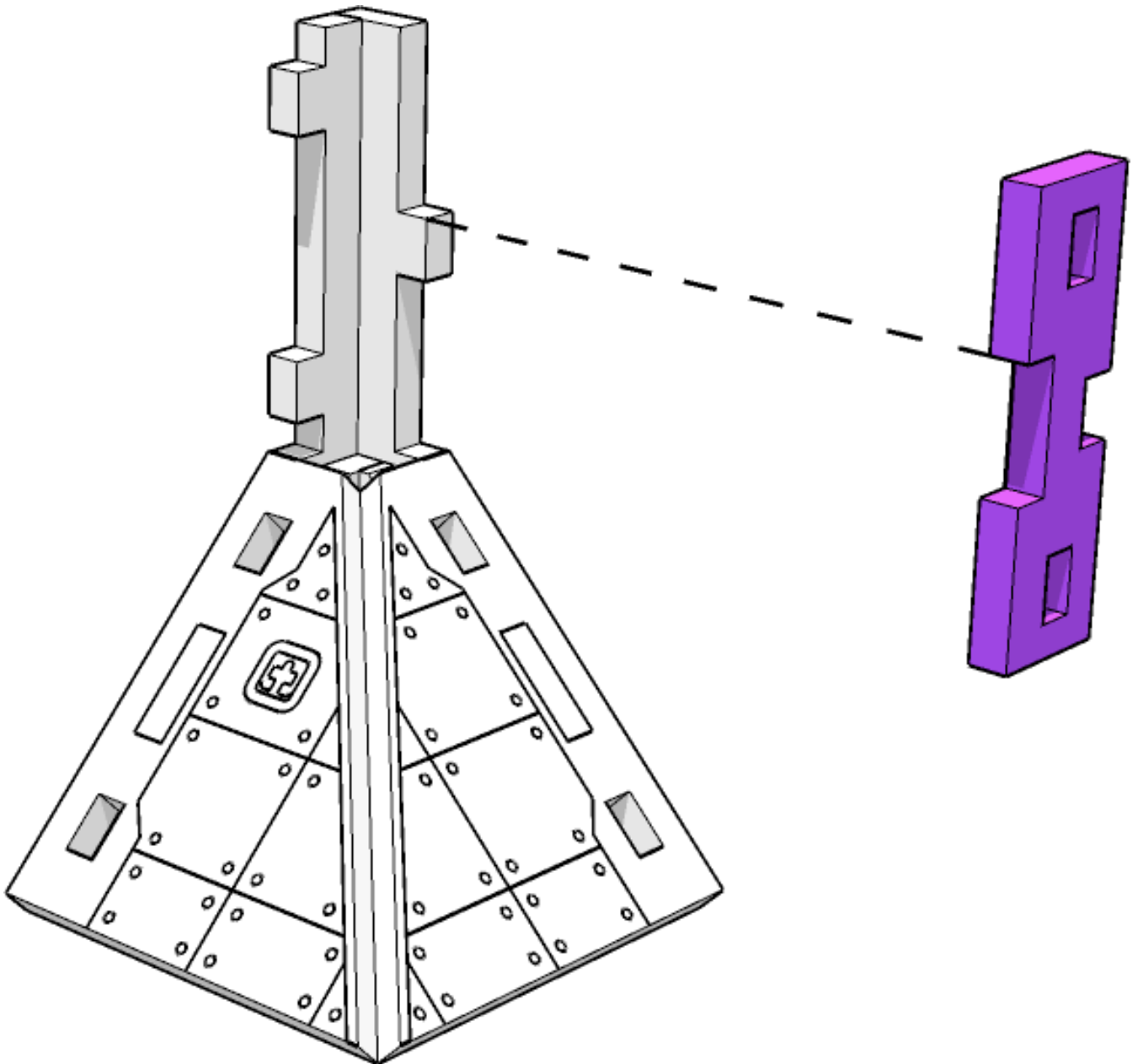



TABLETOP SCENICS

TTSCW-SFU-115
Mod.Co.N
Corner Junction

21

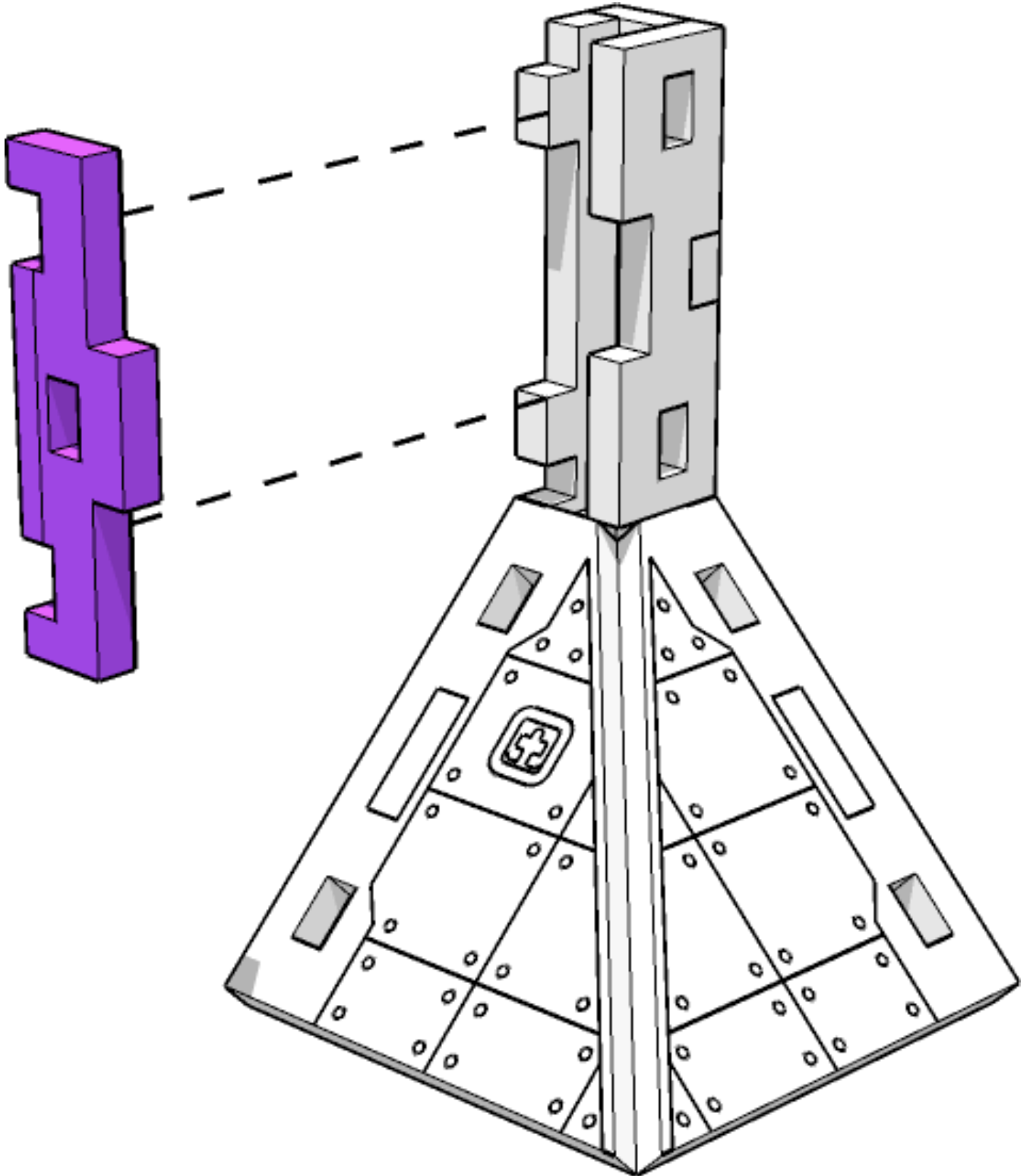



TABLETOP SCENICS

TTSCW-SFU-115
Mod.Co.N
Corner Junction

22

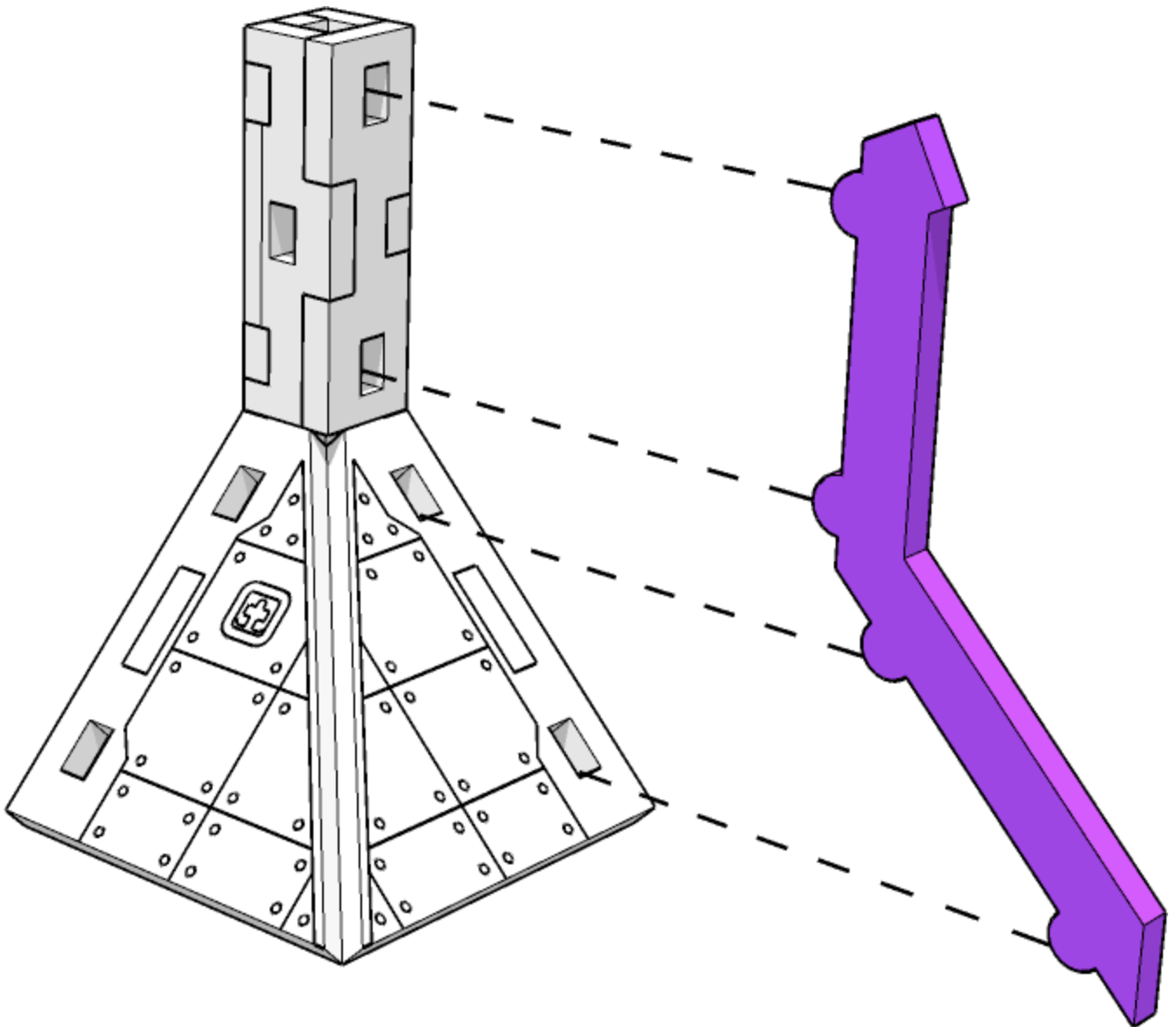



TABLETOP SCENICS

TTSCW-SFU-115
Mod.Co.N
Corner Junction

23

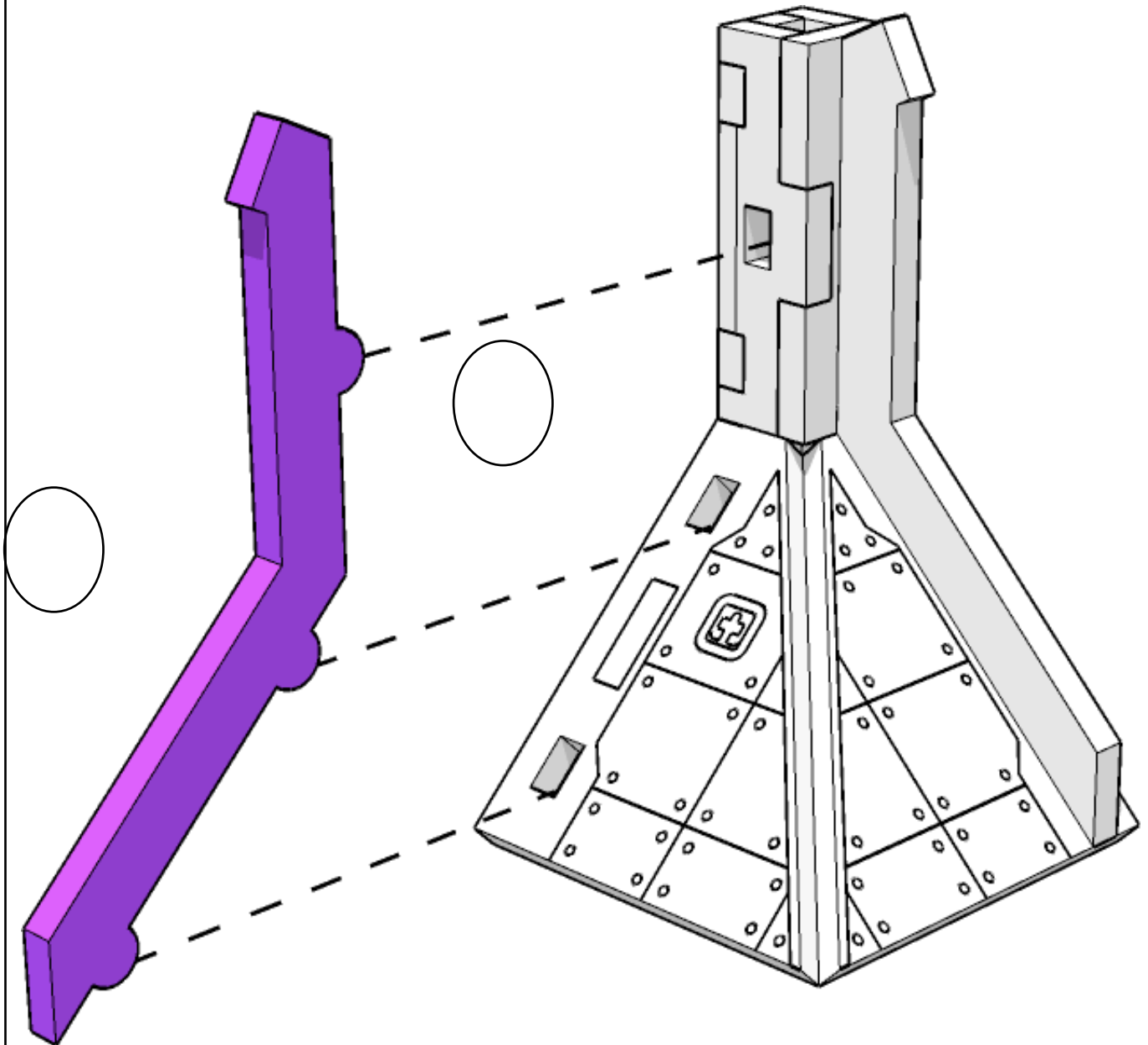

The highlighted part only has one connector at the top



TTCOMBAT



TABLETOP SCENICS

TTSCW-SFU-115
Mod.Co.N
Corner Junction

24

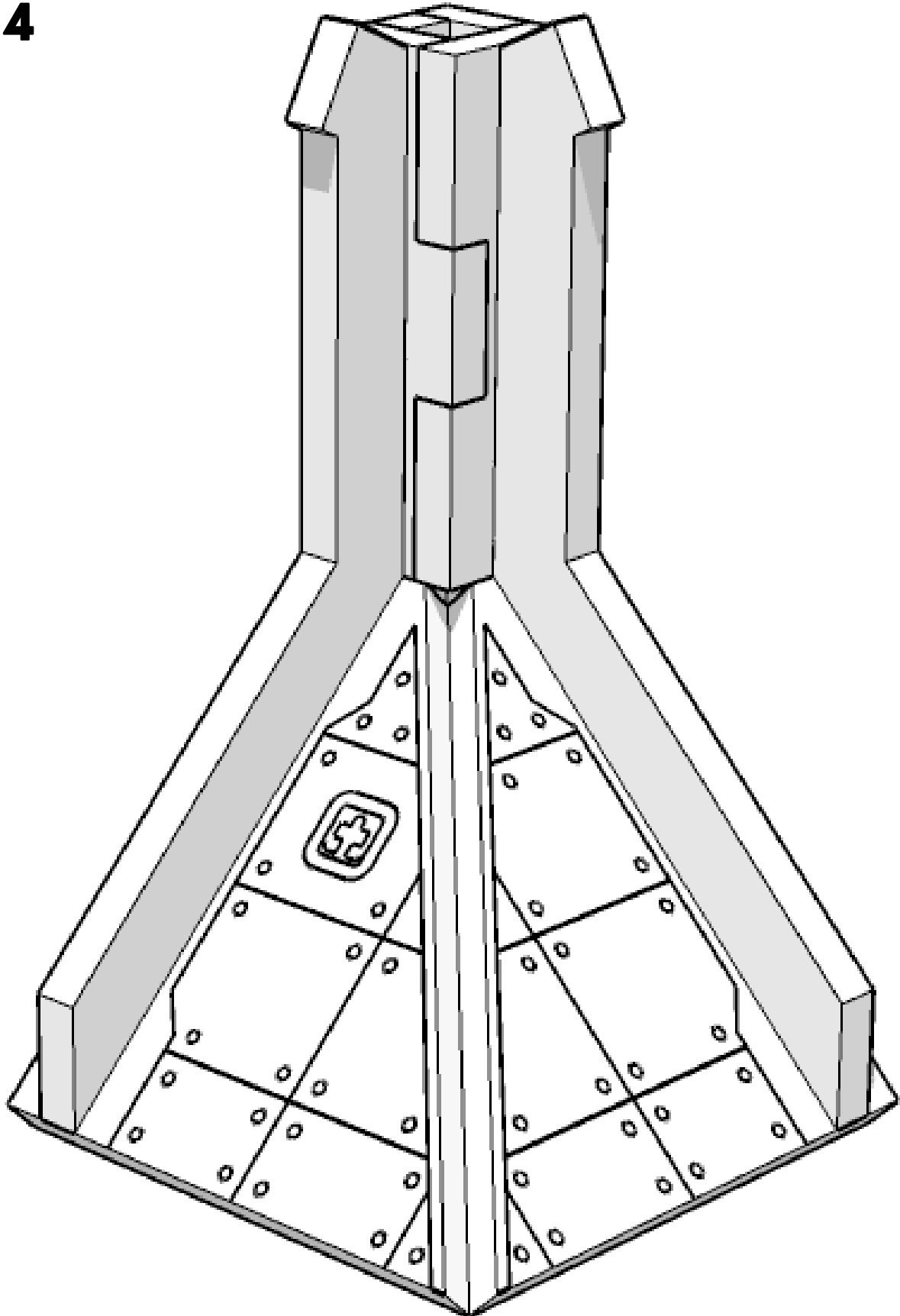



TABLETOP SCENICS

TTSCW-SFU-115
Mod.Co.N
Corner Junction

25

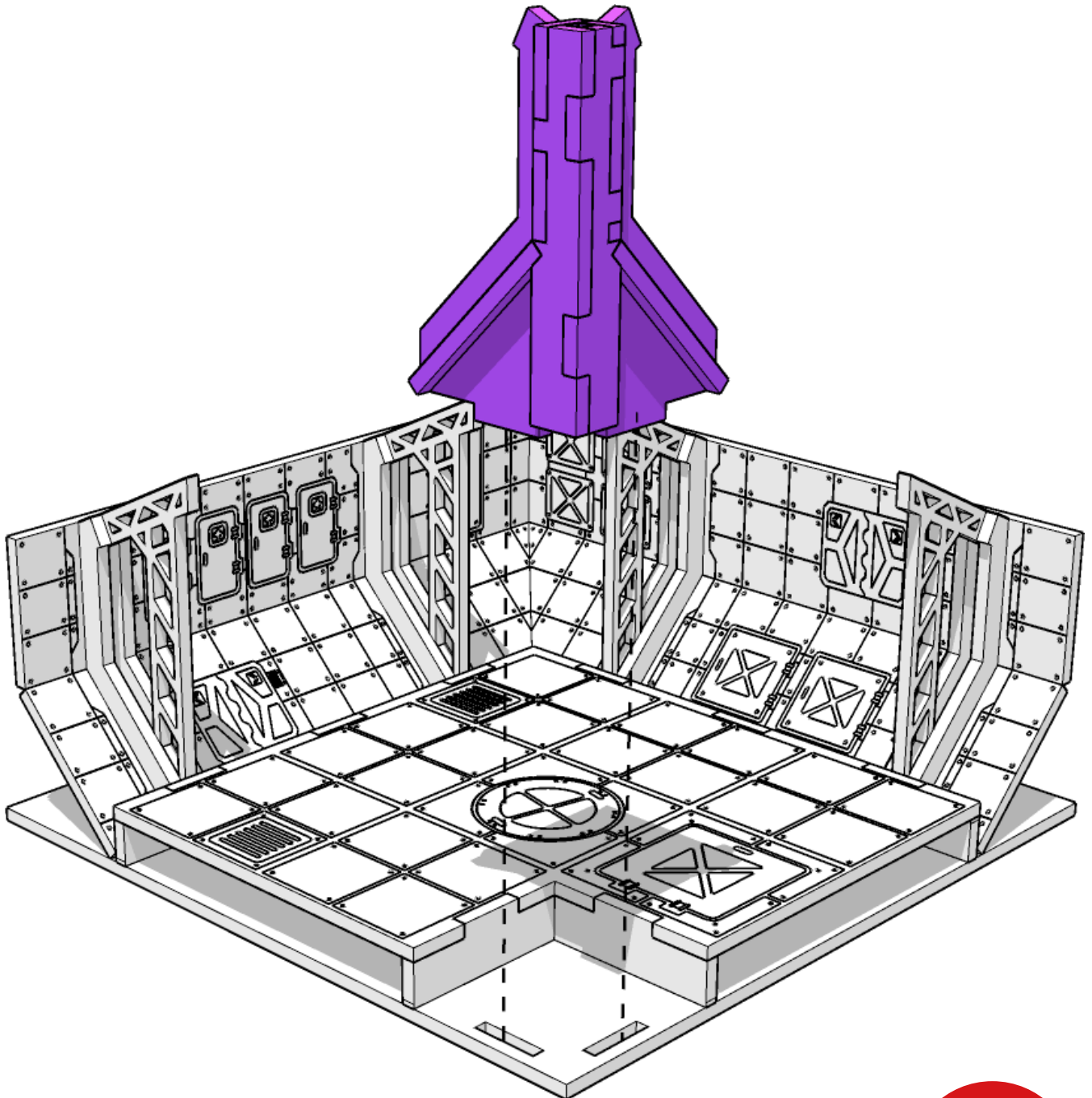

Recommended to not glue in place to allow flexibility between switching the corner strut and corner flat expansions for different layouts.



 TTCOMBAT



TABLETOP SCENICS

TTSCW-SFU-115
Mod.Co.N
Corner Junction

26

