

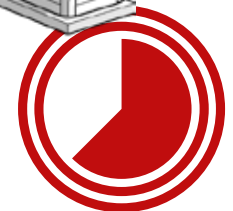

TABLETOP
SCENICS

TTSCW-EES-110
Toshi
Hakkei-tō Pagoda

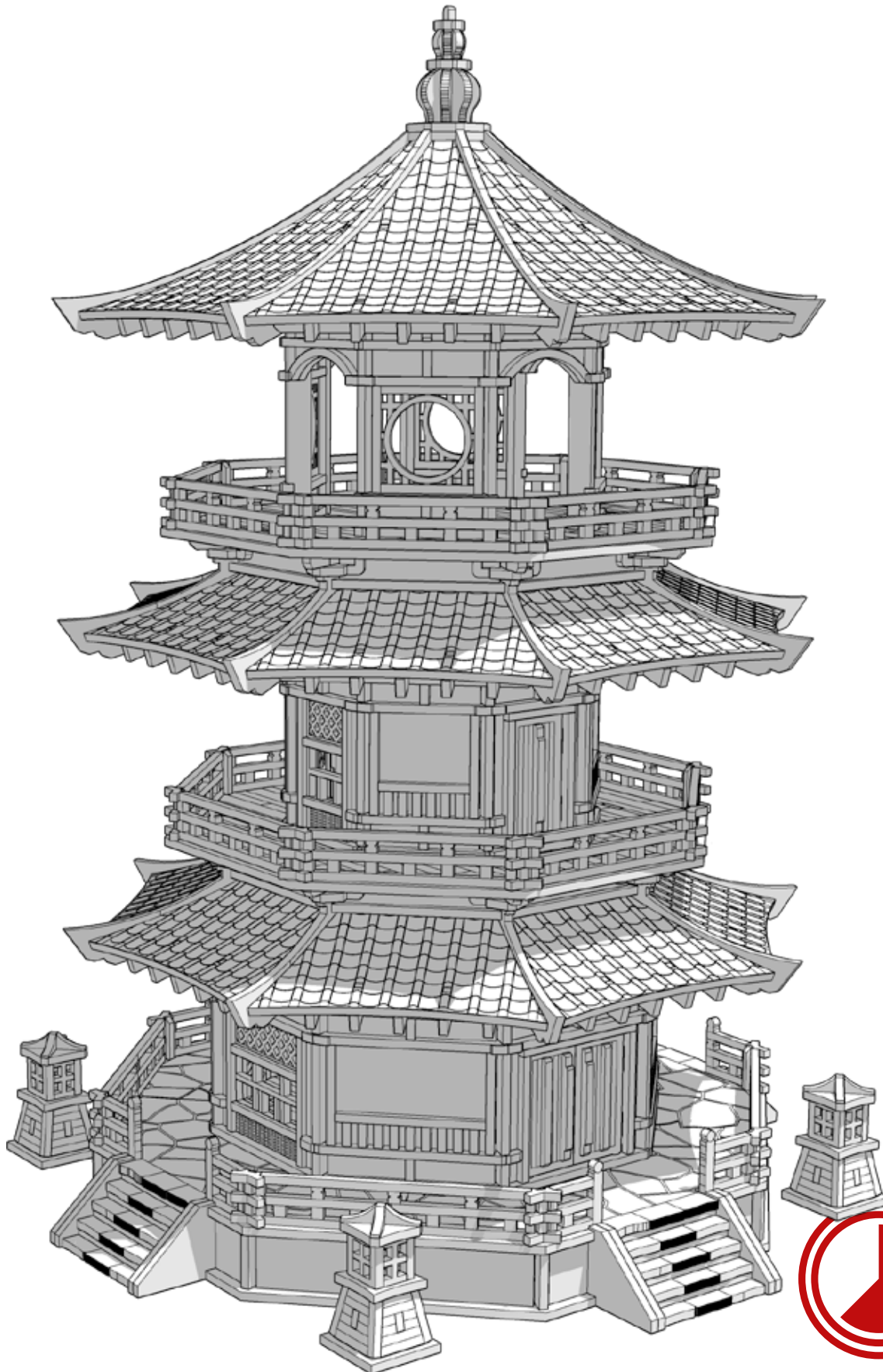

 **TTCOMBAT**



TABLETOP SCENICS

TTSCW-EES-110 Toshi Hakkei-tō Pagoda

2

These are a series of icons that may be used throughout the instructions to help your assembly.
If in doubt, scroll ahead to confirm.



Do not glue this part



Carefully score and
fold this part

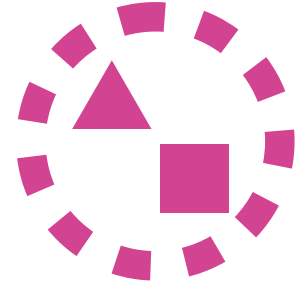

This part - or its placement is
completely optional



Look closely at this step -
The process order or part
used, may be specific



Repeat making this part
the specified number
of times



The next instruction step
will be the same assembly
so far, but from a different
angle

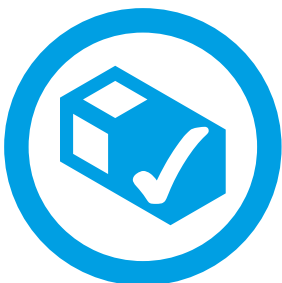

Sub-assembly complete.
This smaller construction
is ready to add to the
main kit



Assembly Complete! There
could be more optional
parts - check to the very end
of instructions



FRAGILE: DO NOT BEND.
“Bendy wood” is designed to
curve around a designed
frame only.



TABLETOP SCENICS

TTSCW-EES-110
Toshi
Hakkei-tō Pagoda

3

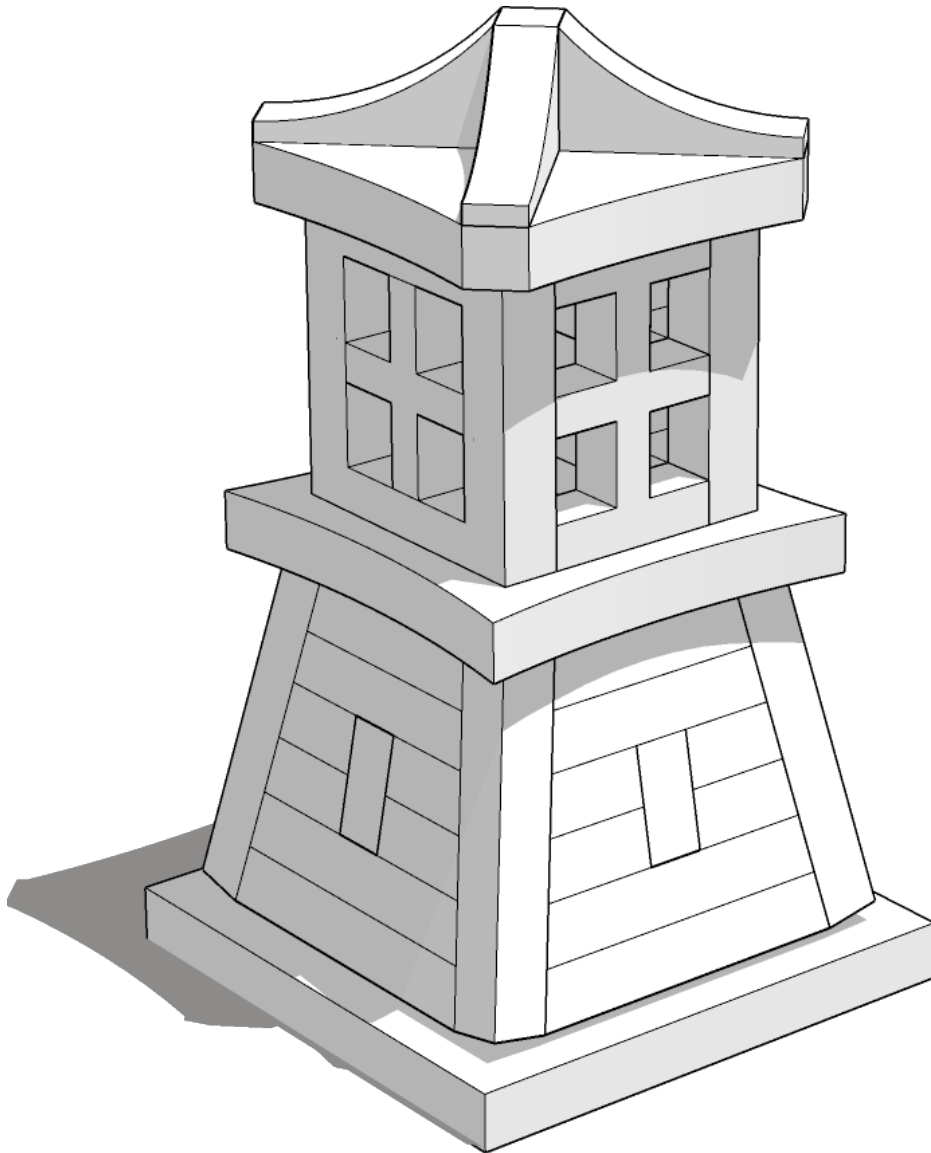



TABLETOP SCENICS

TTSCW-EES-110
Toshi
Hakkei-tō Pagoda

4

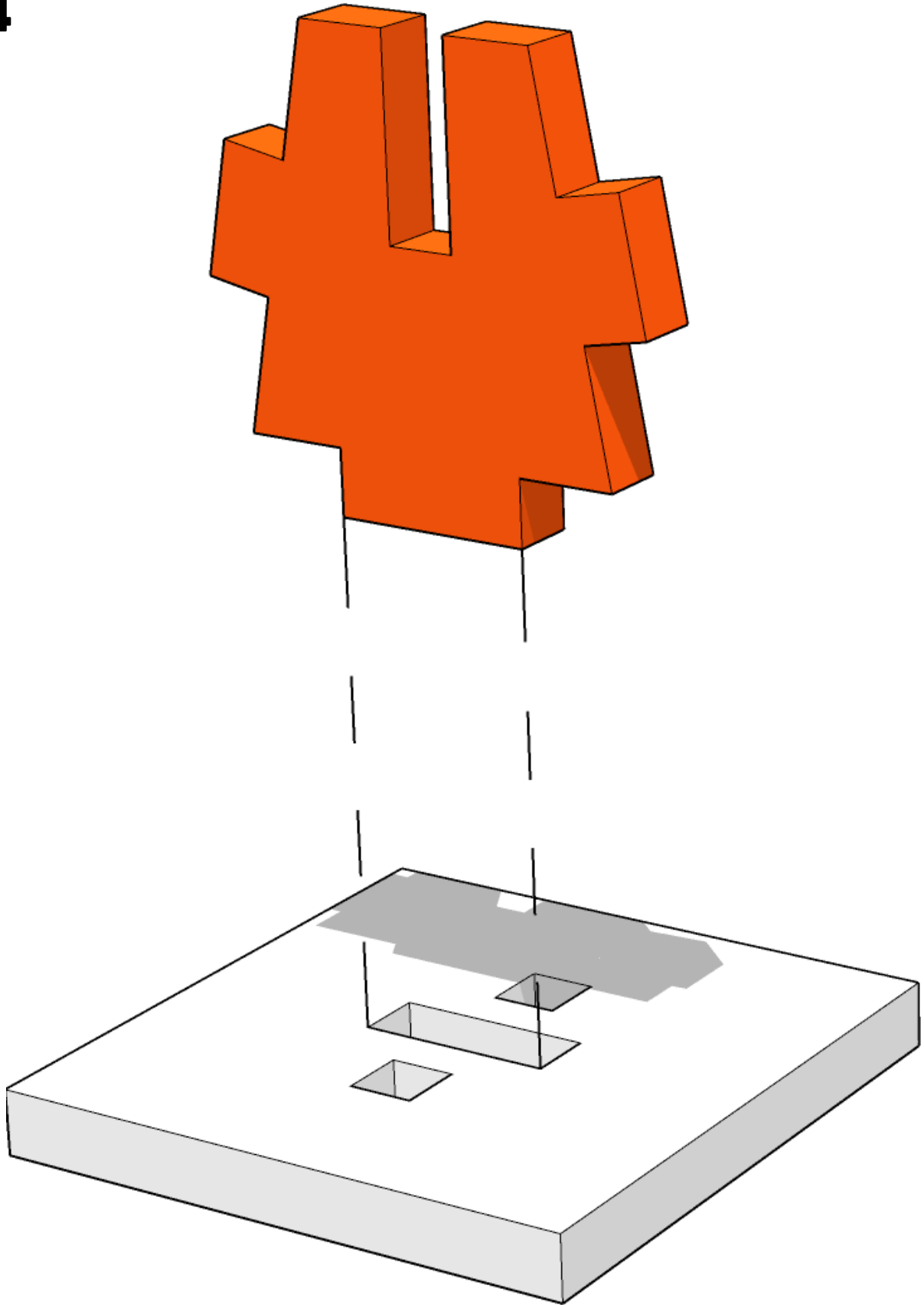



TABLETOP SCENICS

TTSCW-EES-110
Toshi
Hakkei-tō Pagoda

5

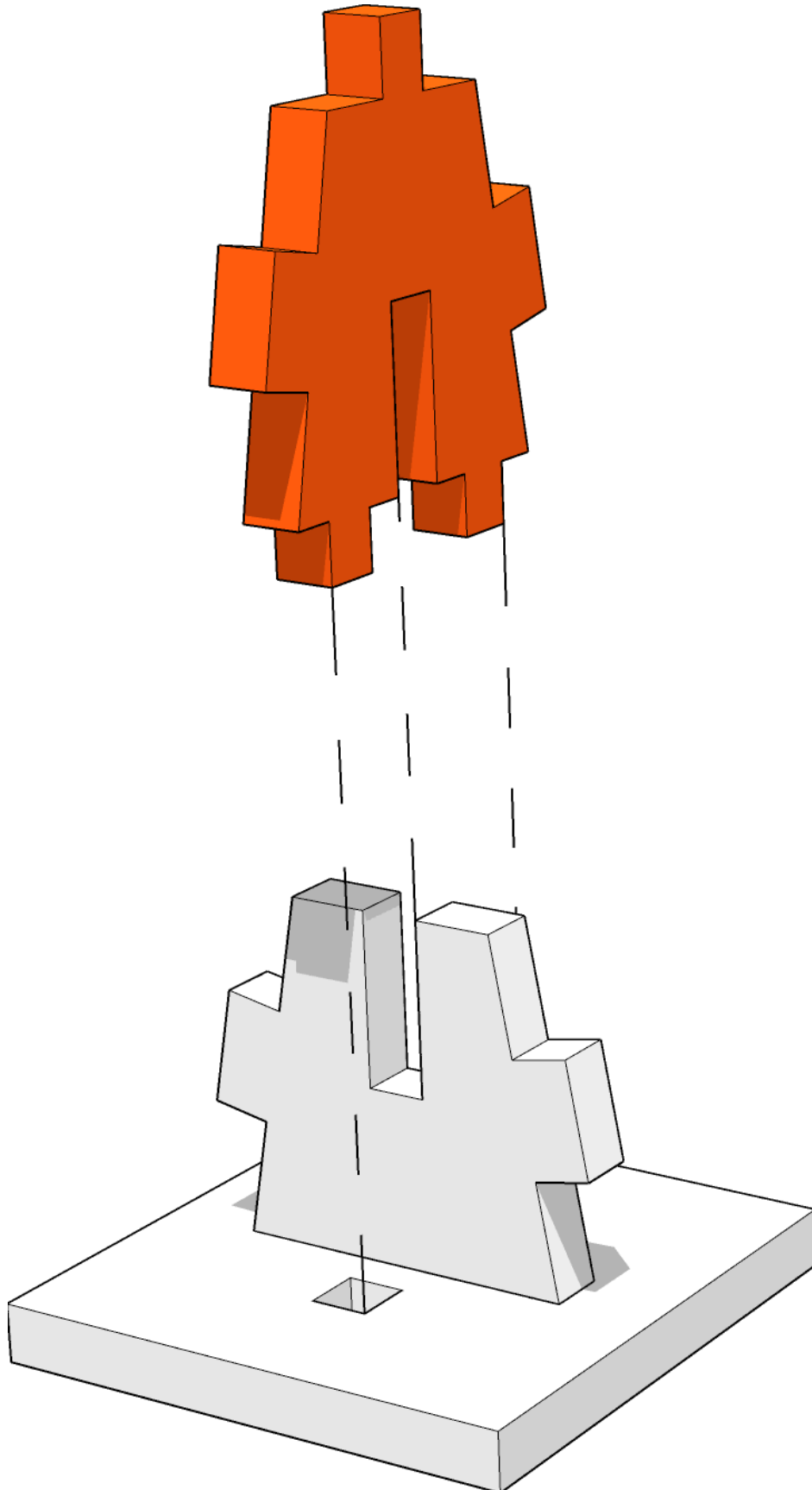



TABLETOP SCENICS

TTSCW-EES-110
Toshi
Hakkei-tō Pagoda

6

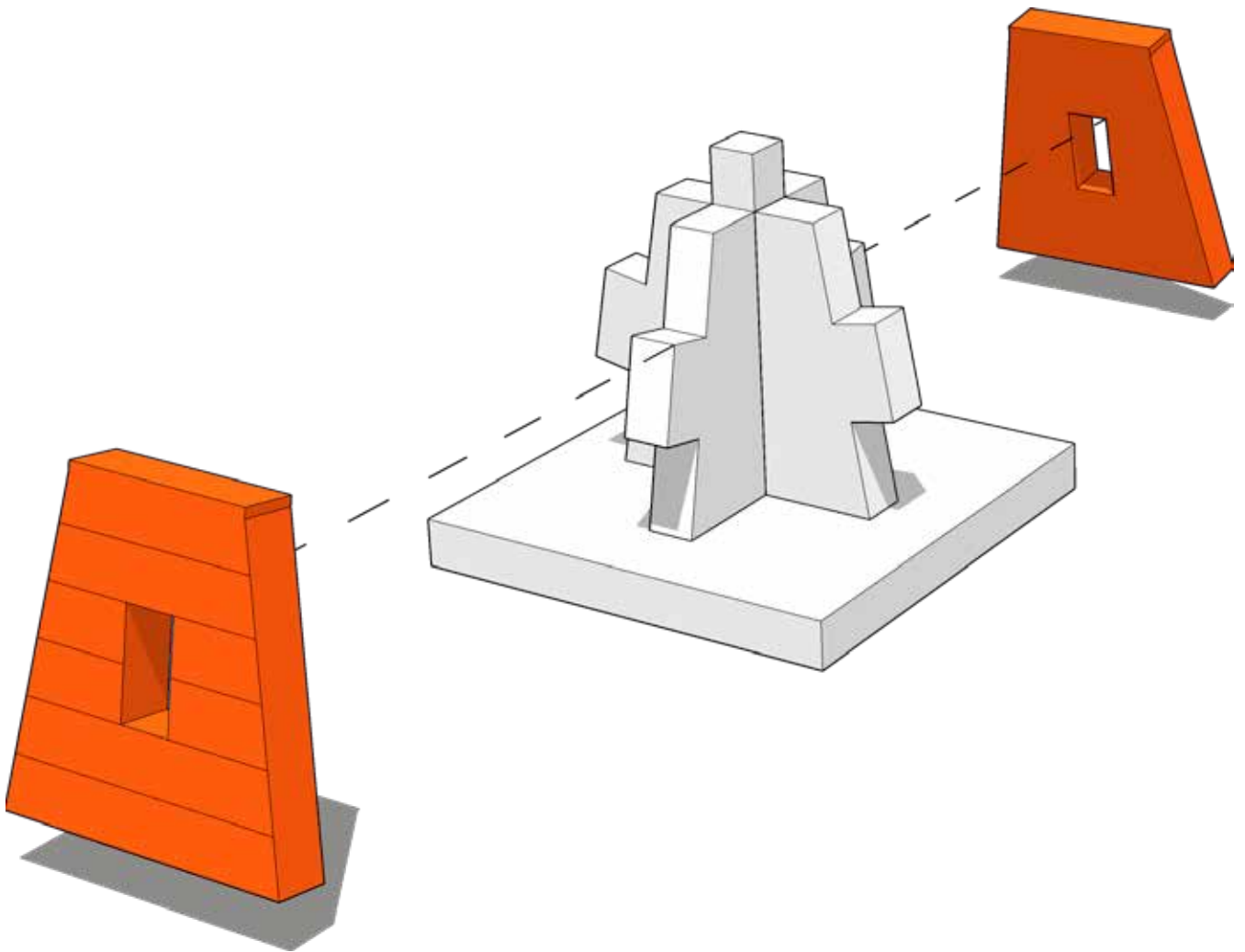



TABLETOP SCENICS

TTSCW-EES-110
Toshi
Hakkei-tō Pagoda

7

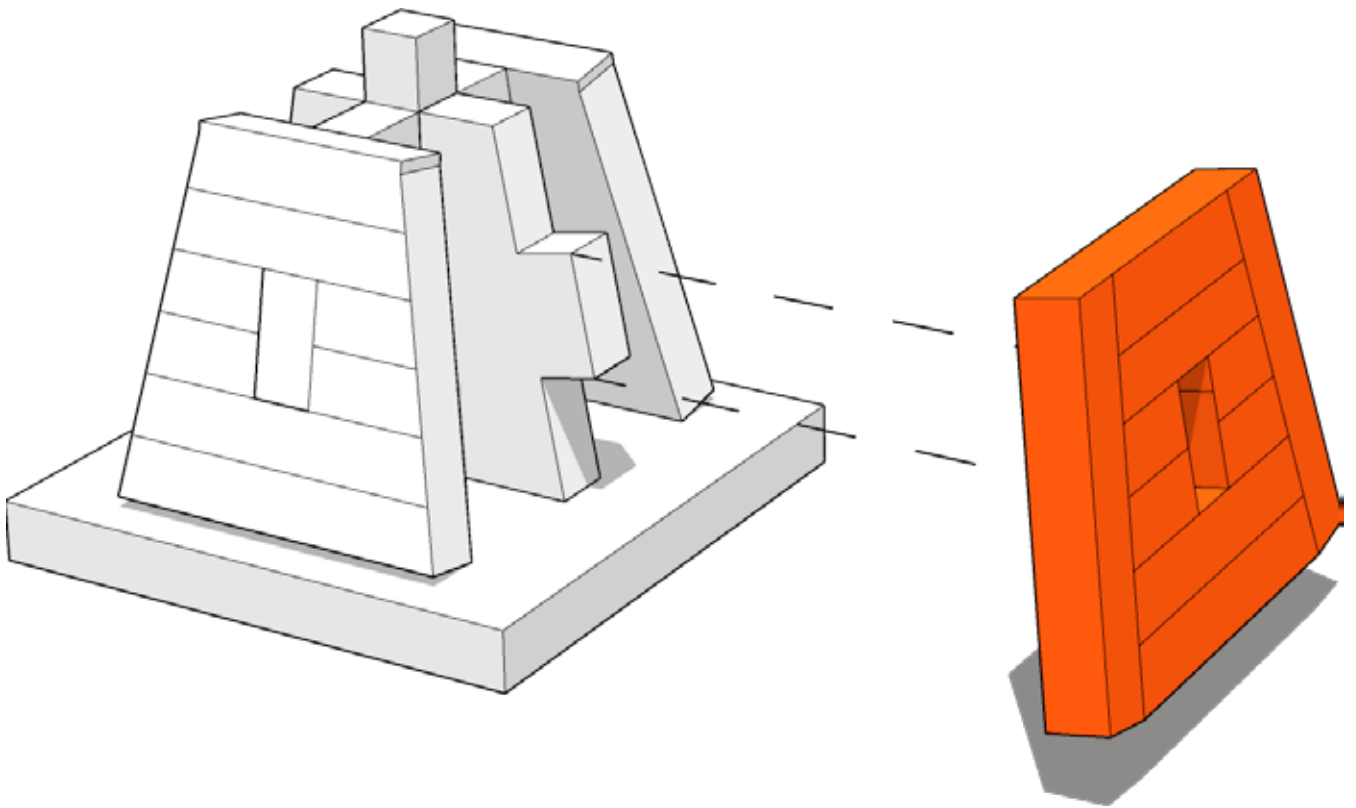



TABLETOP SCENICS

TTSCW-EES-110
Toshi
Hakkei-tō Pagoda

8

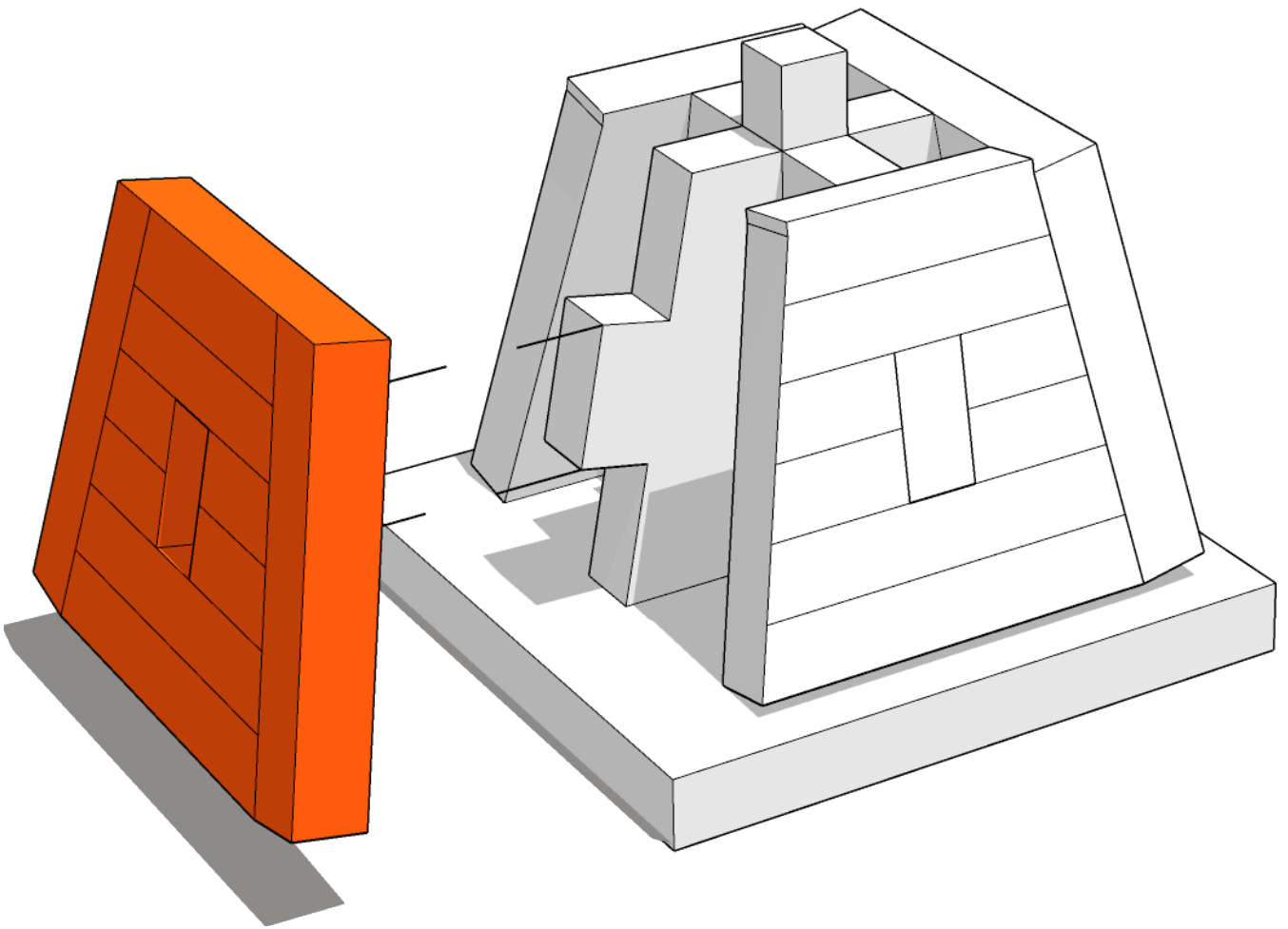



TABLETOP SCENICS

TTSCW-EES-110
Toshi
Hakkei-tō Pagoda

9

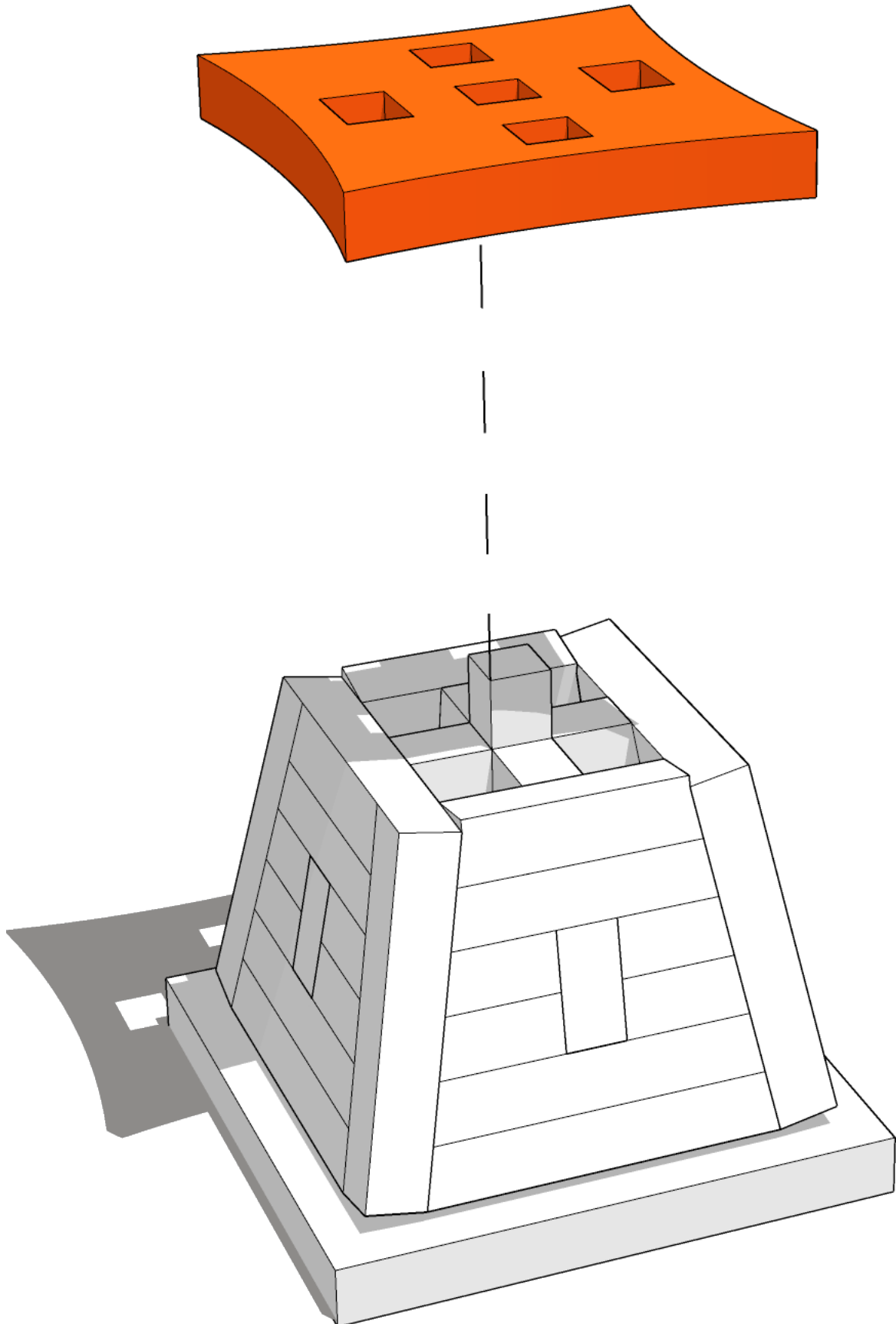



TABLETOP SCENICS

TTSCW-EES-110
Toshi
Hakkei-tō Pagoda

10

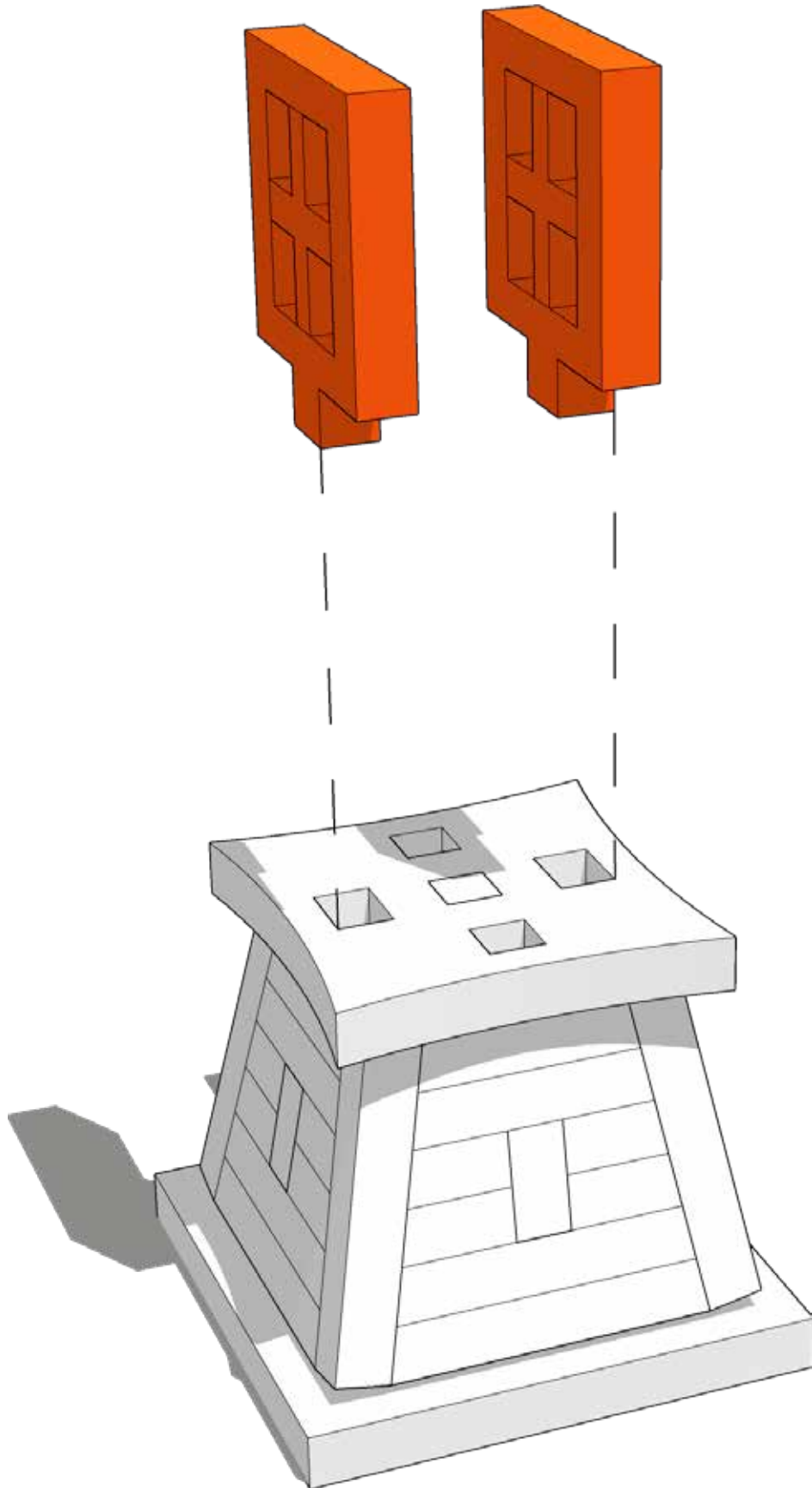



TABLETOP SCENICS

TTSCW-EES-110
Toshi
Hakkei-tō Pagoda

11

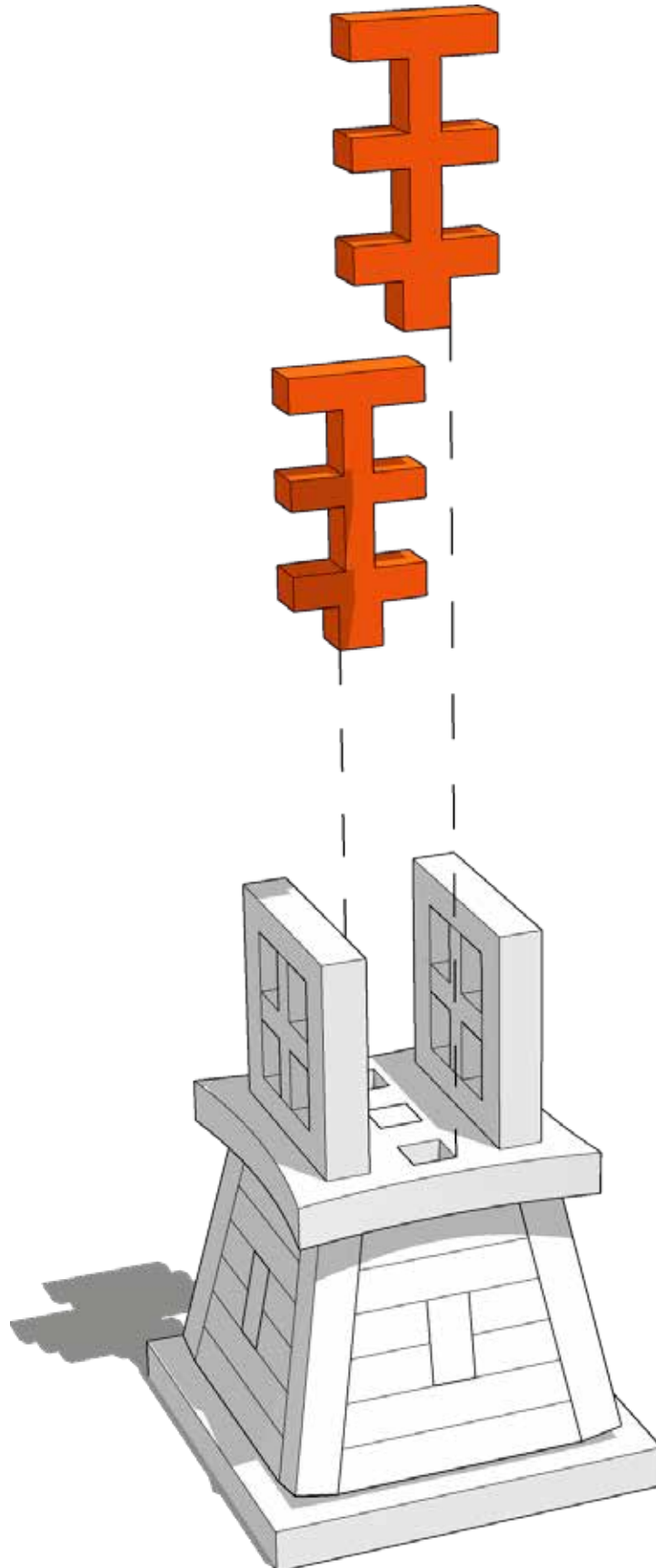



TABLETOP SCENICS

TTSCW-EES-110
Toshi
Hakkei-tō Pagoda

12

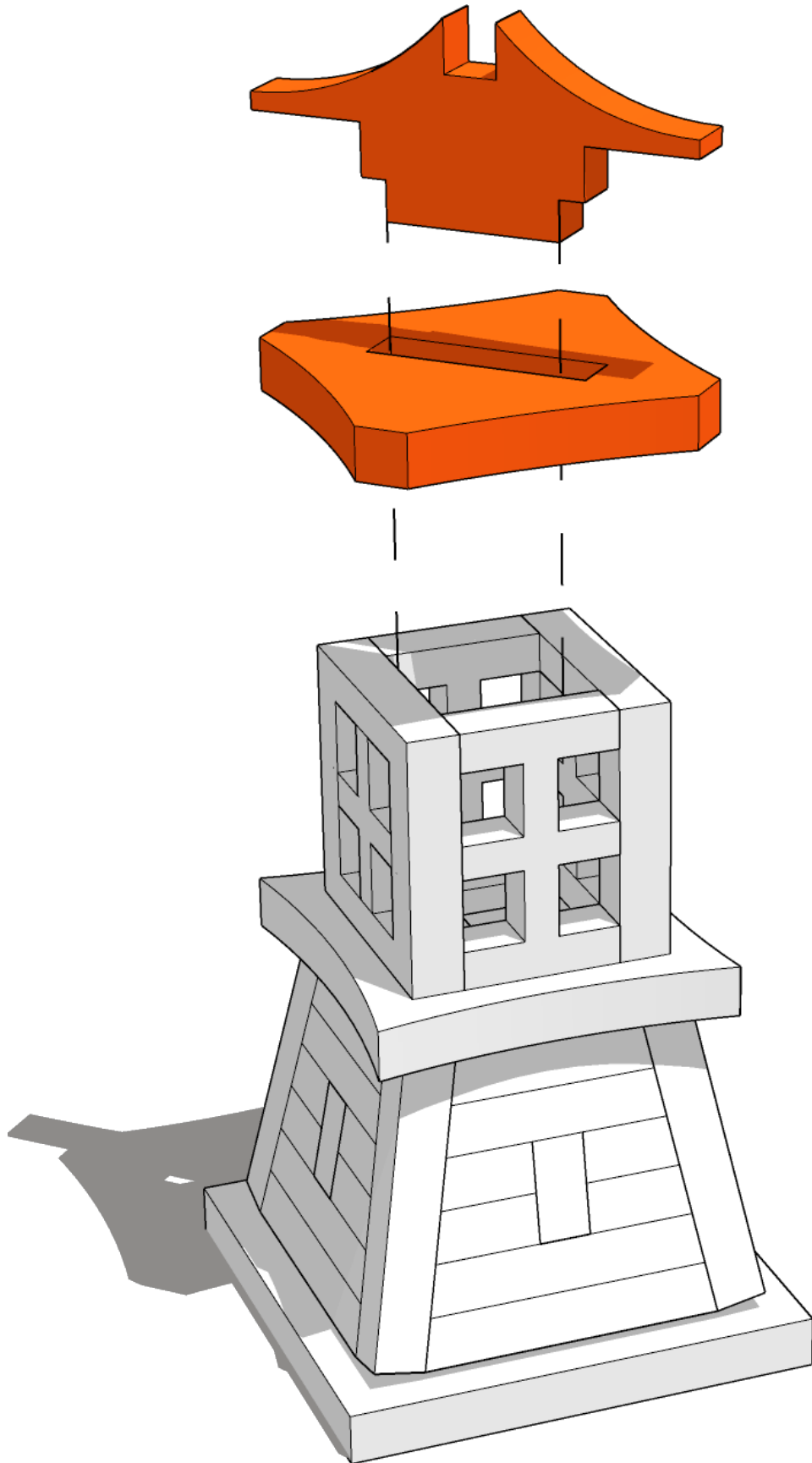



TABLETOP SCENICS

TTSCW-EES-110
Toshi
Hakkei-tō Pagoda

13

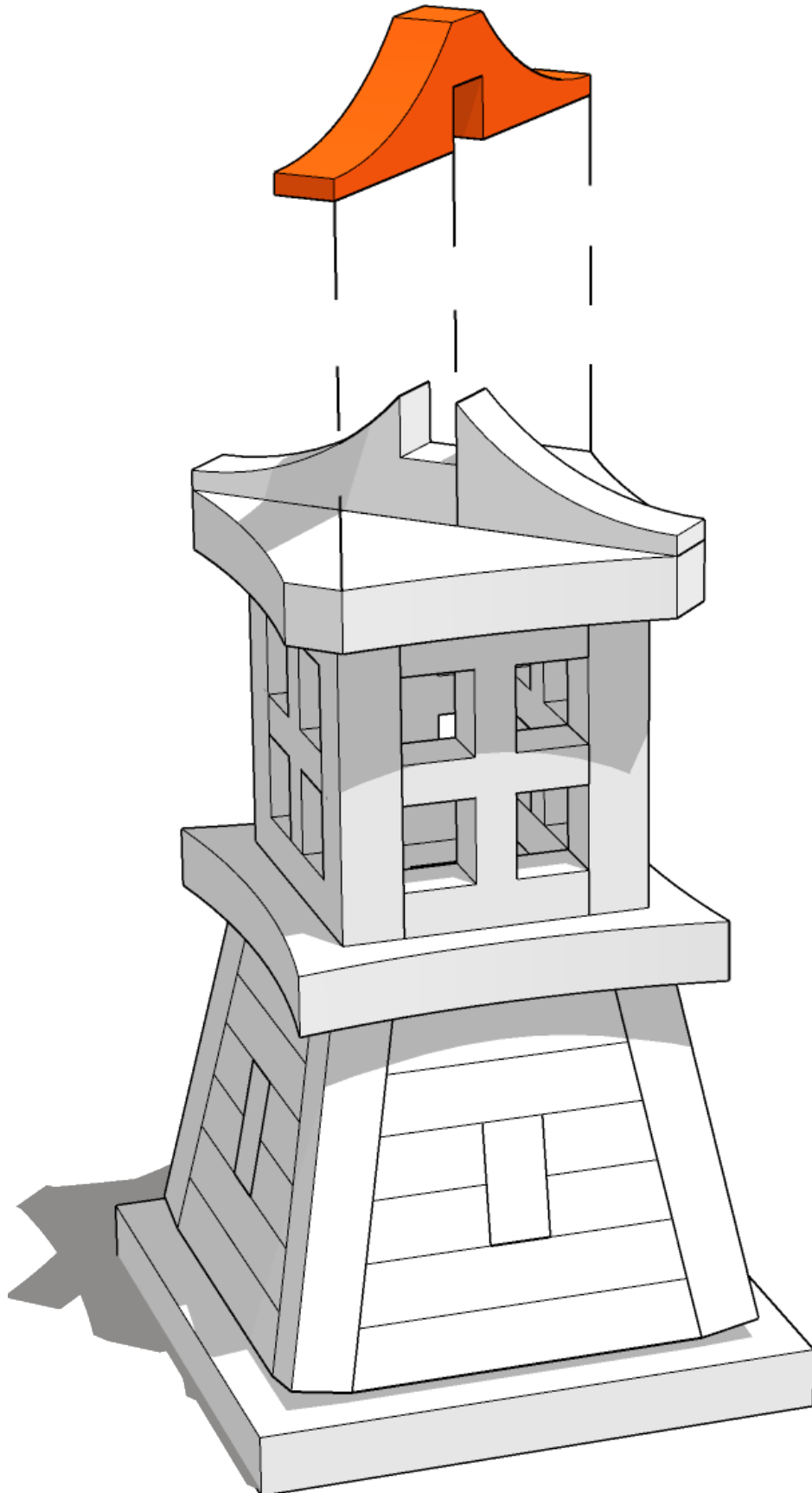



TABLETOP SCENICS

TTSCW-EES-110
Toshi
Hakkei-tō Pagoda

14

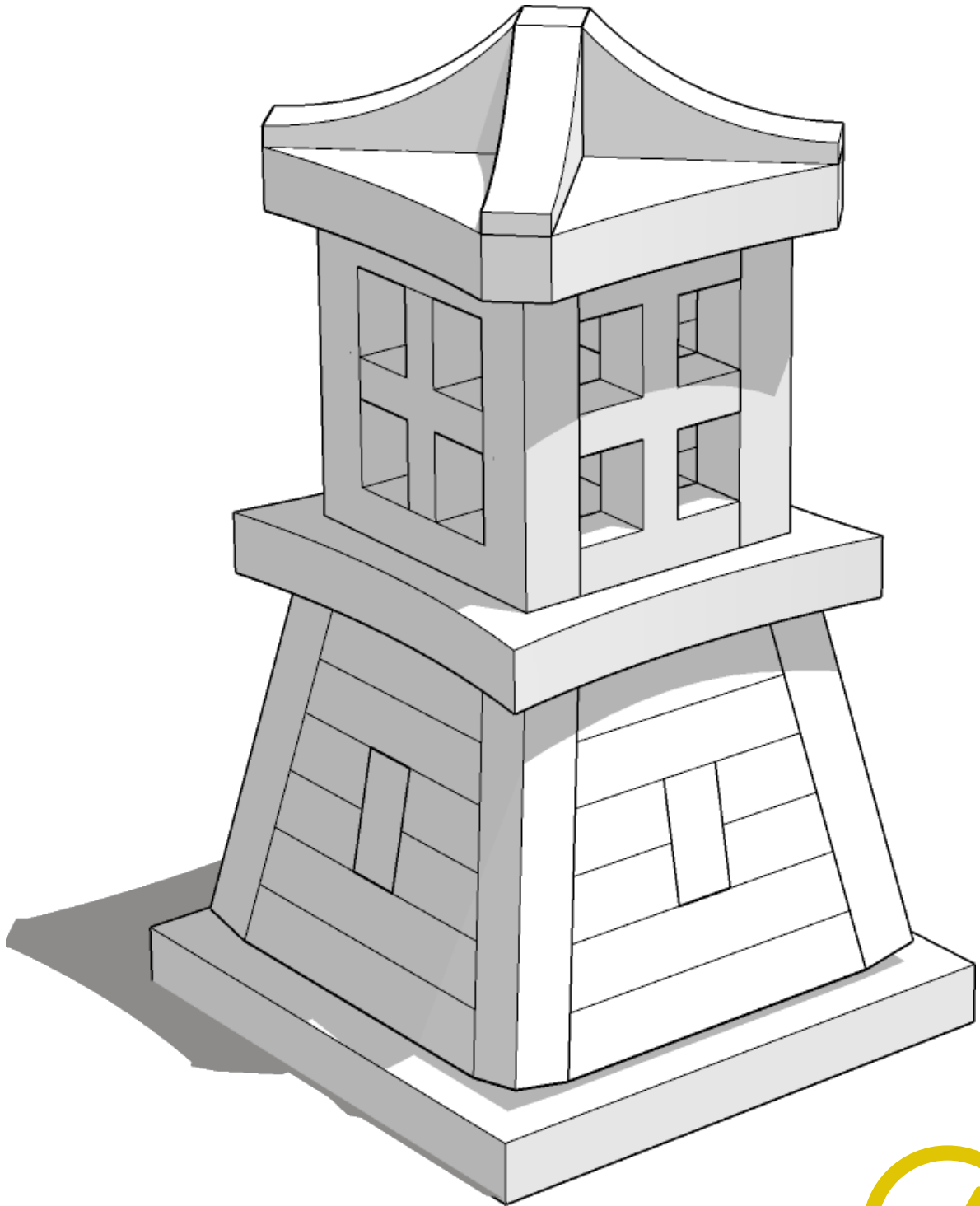

x4

 TTCOMBAT



TABLETOP SCENICS

TTSCW-EES-110
Toshi
Hakkei-tō Pagoda

15

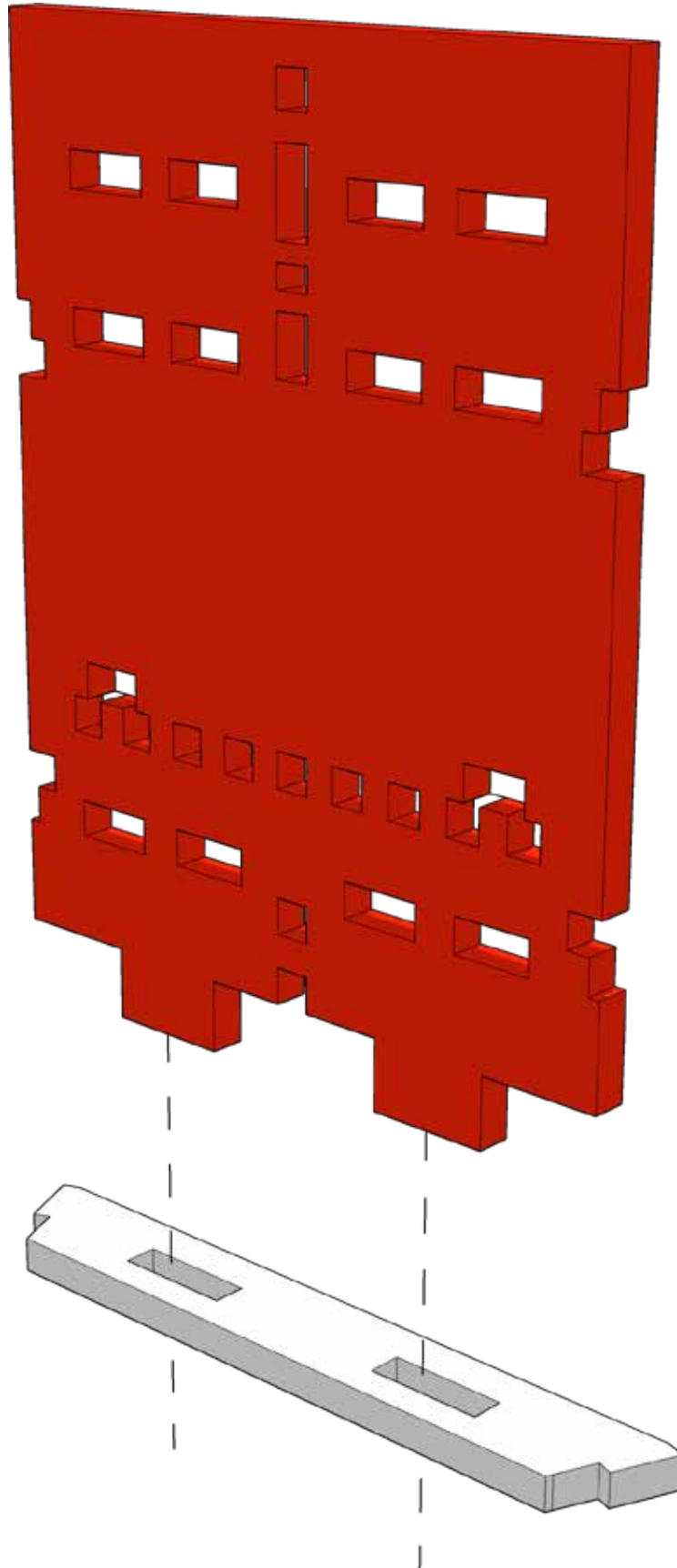



TABLETOP SCENICS

TTSCW-EES-110
Toshi
Hakkei-tō Pagoda

16

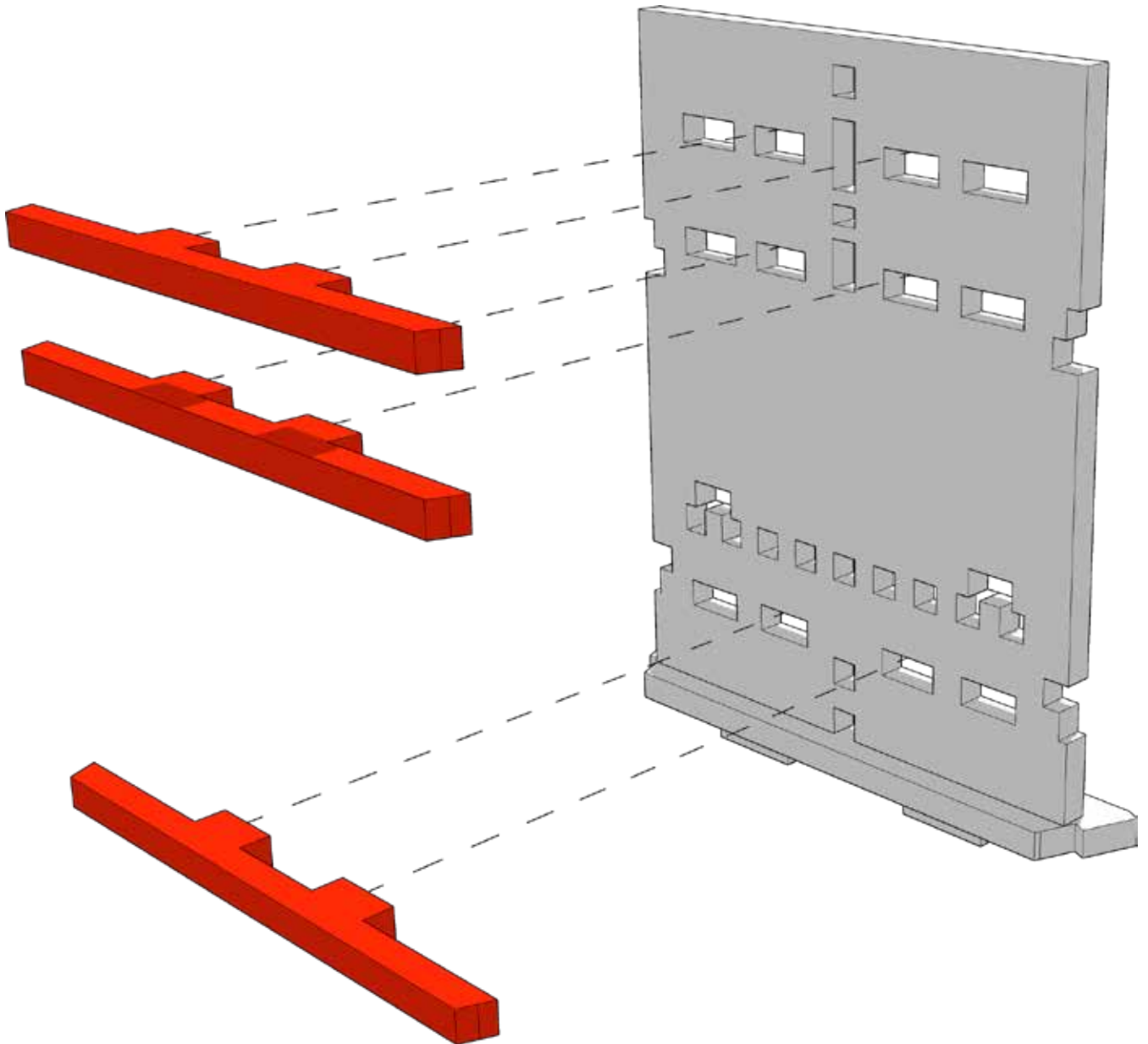



TABLETOP SCENICS

TTSCW-EES-110
Toshi
Hakkei-tō Pagoda

17

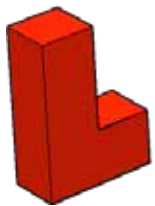
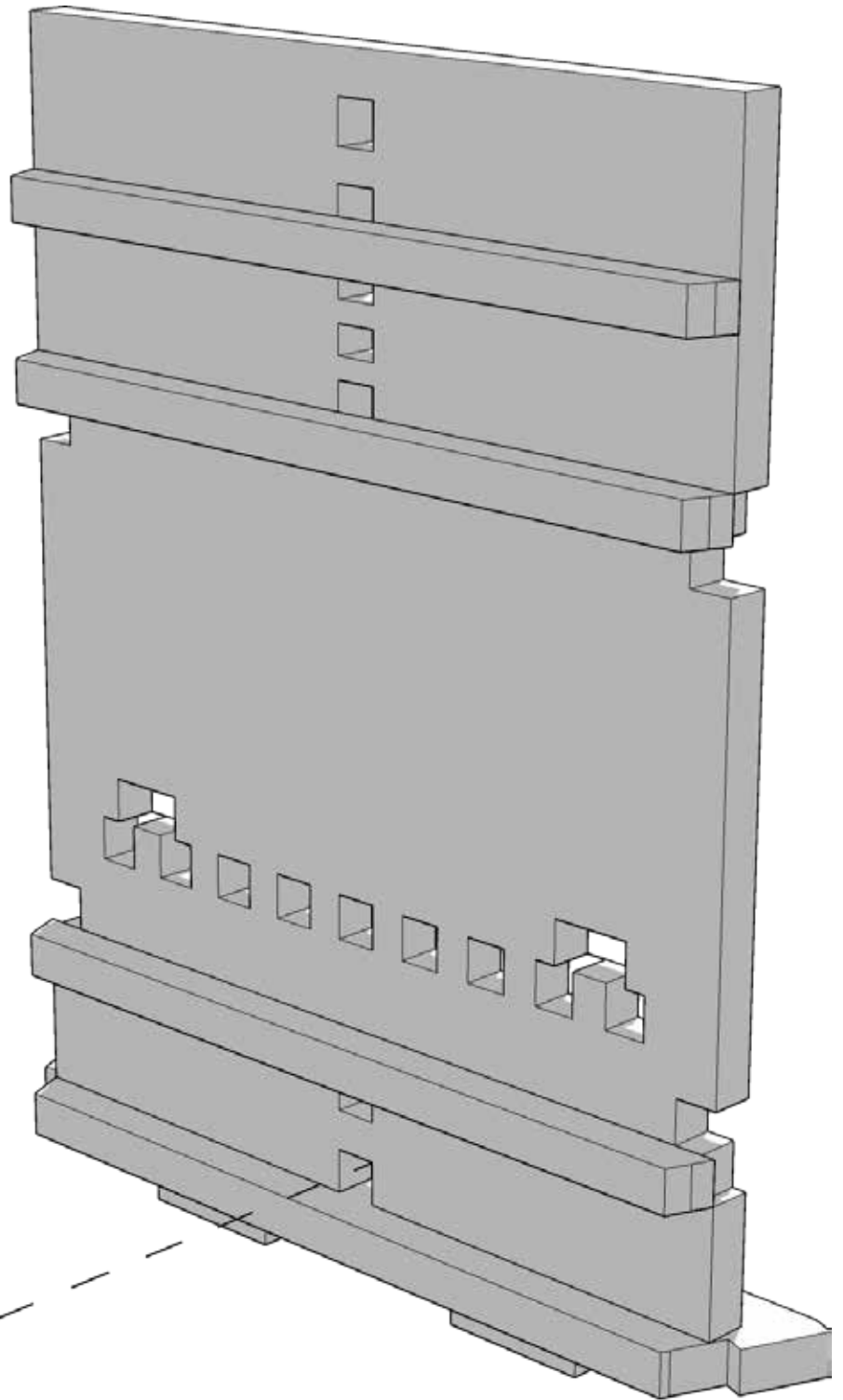



TABLETOP SCENICS

TTSCW-EES-110
Toshi
Hakkei-tō Pagoda

18

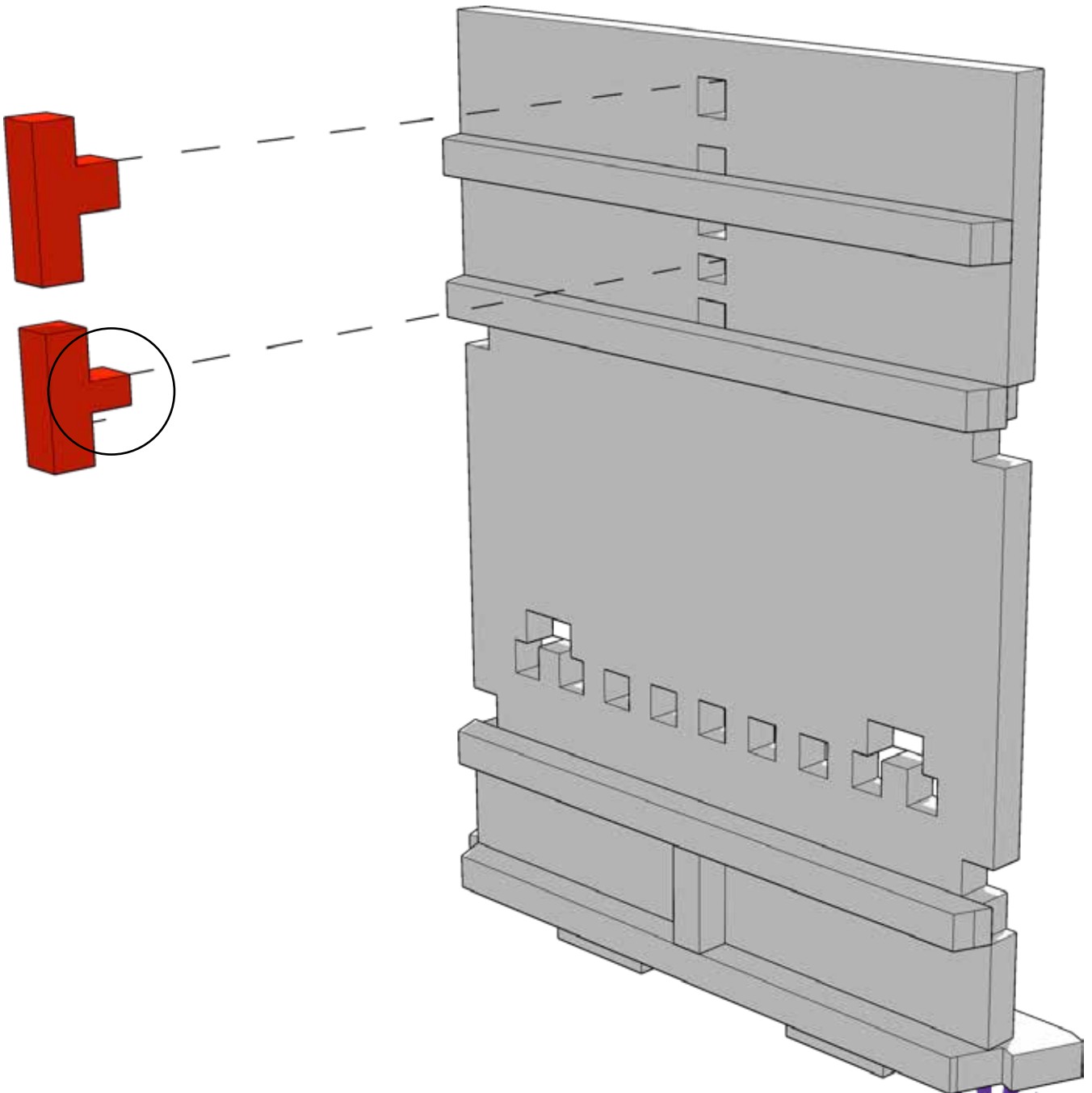

Circled part has a smaller tab than the one above and is labeled "B" on the sprues. The other is labeled "C"



 **TTCOMBAT**



TABLETOP SCENICS

TTSCW-EES-110
Toshi
Hakkei-tō Pagoda

19

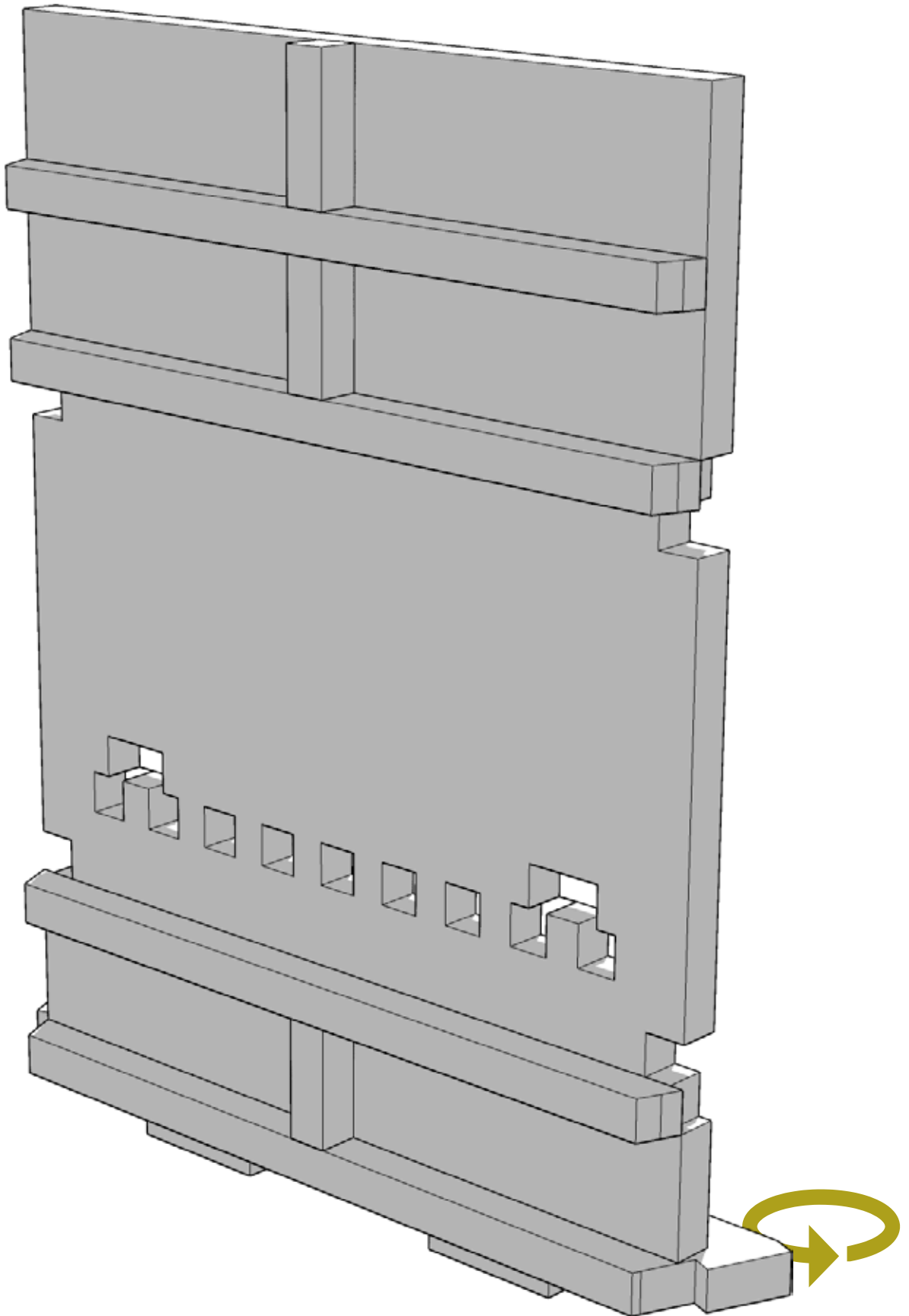



TABLETOP SCENICS

TTSCW-EES-110
Toshi
Hakkei-tō Pagoda

20

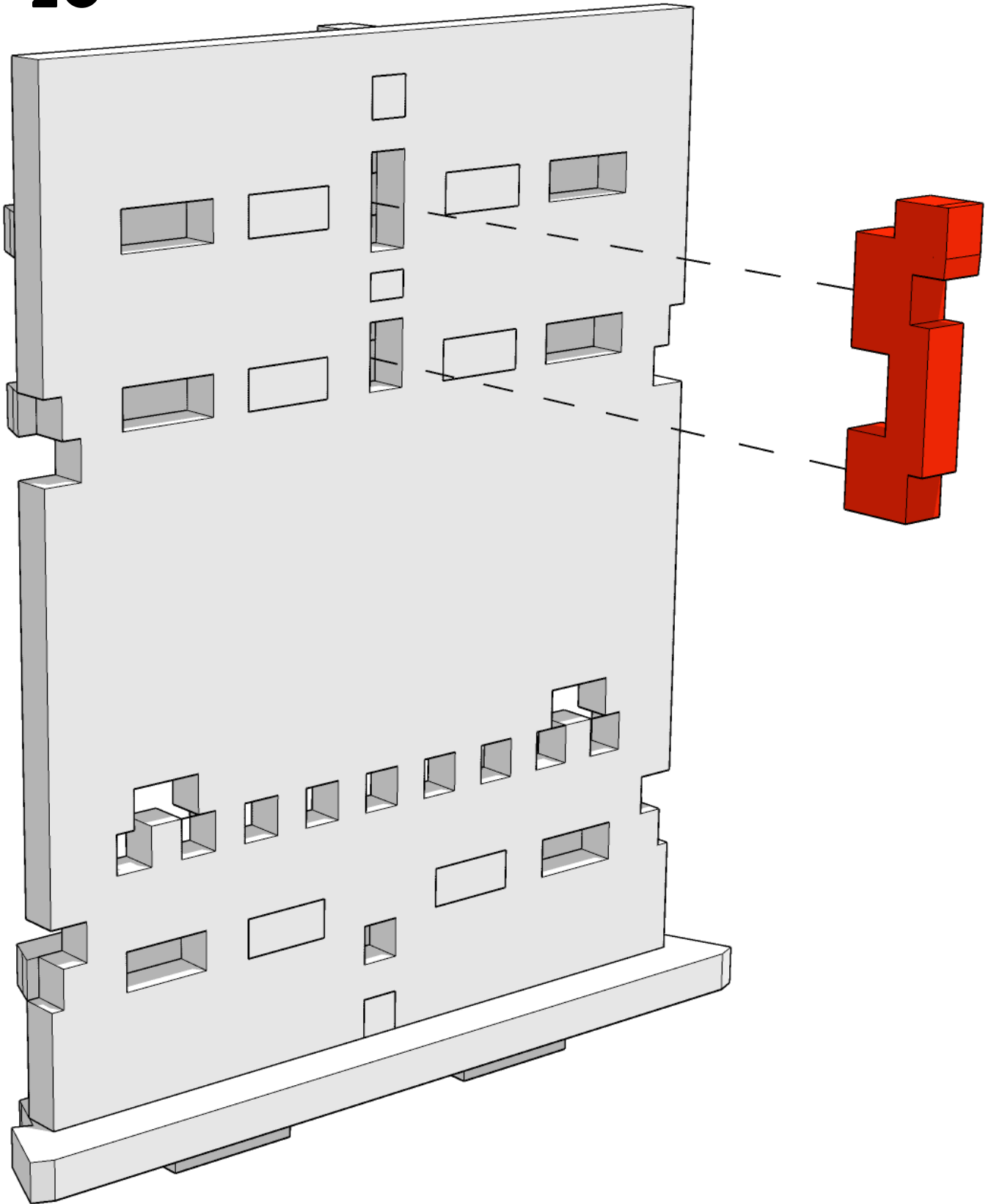



TABLETOP SCENICS

TTSCW-EES-110
Toshi
Hakkei-tō Pagoda

21

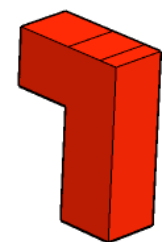
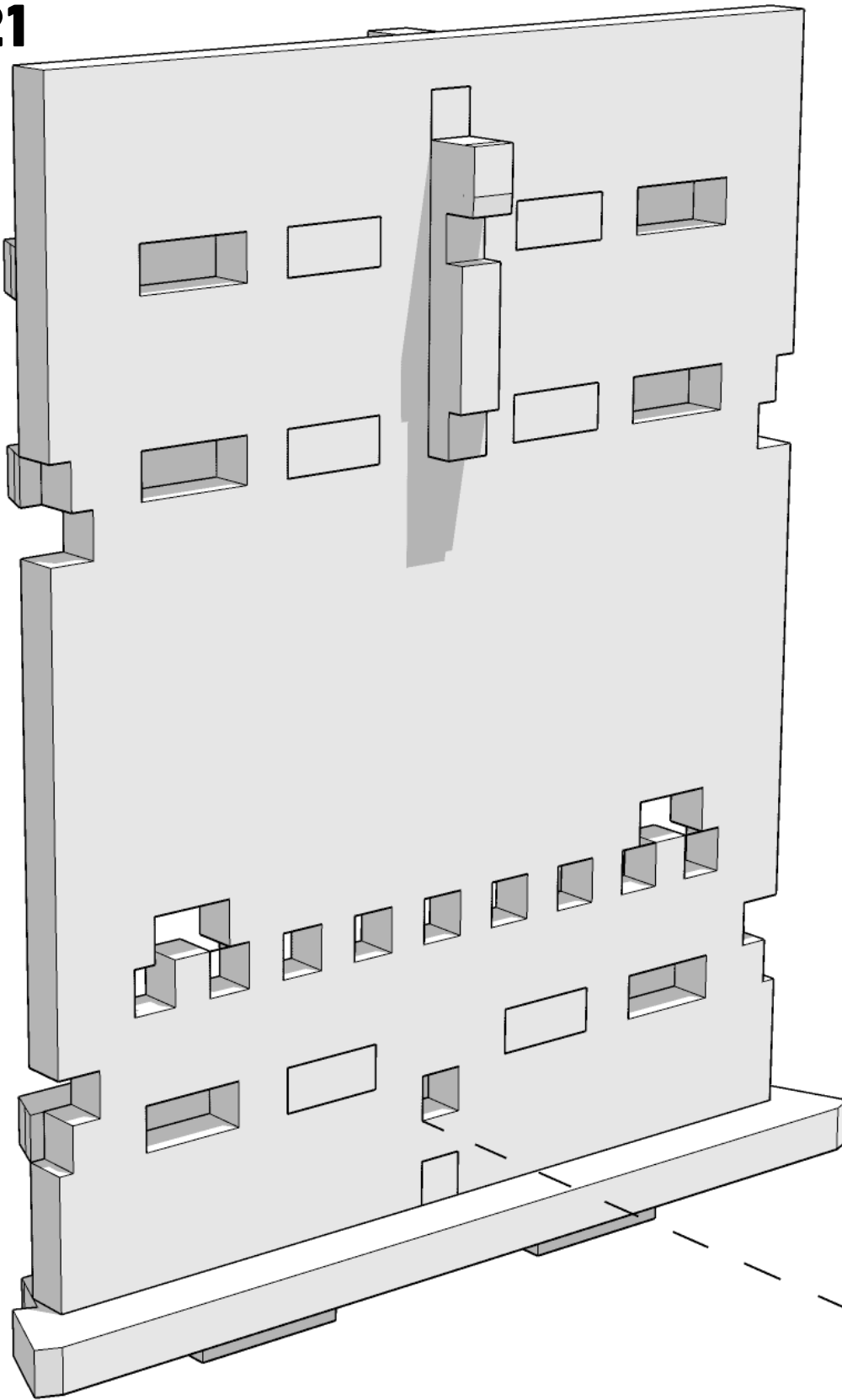



22

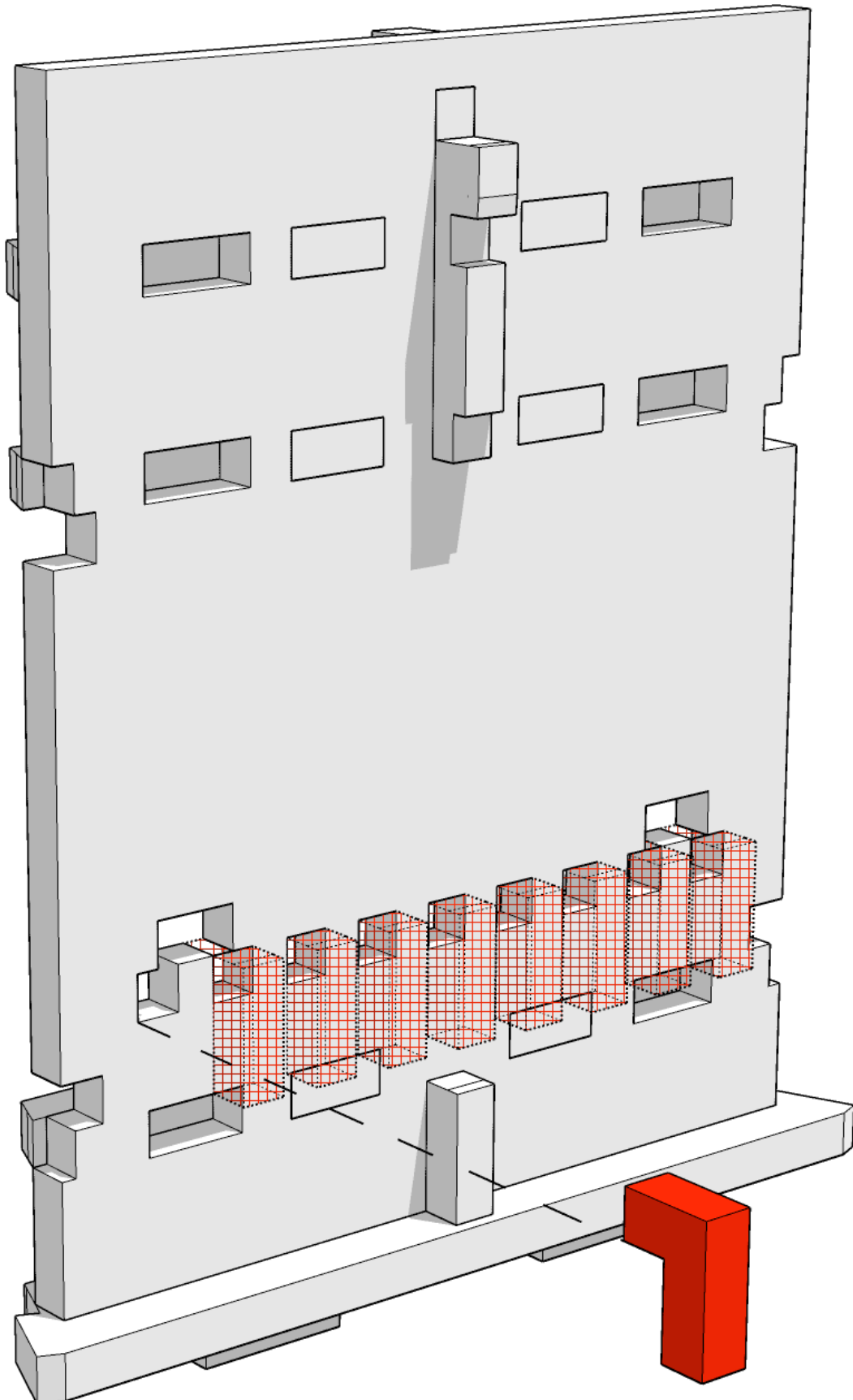

Highlighted part is tagged as "A" on
the sprues



TABLETOP SCENICS

TTSCW-EES-110
Toshi
Hakkei-tō Pagoda

23

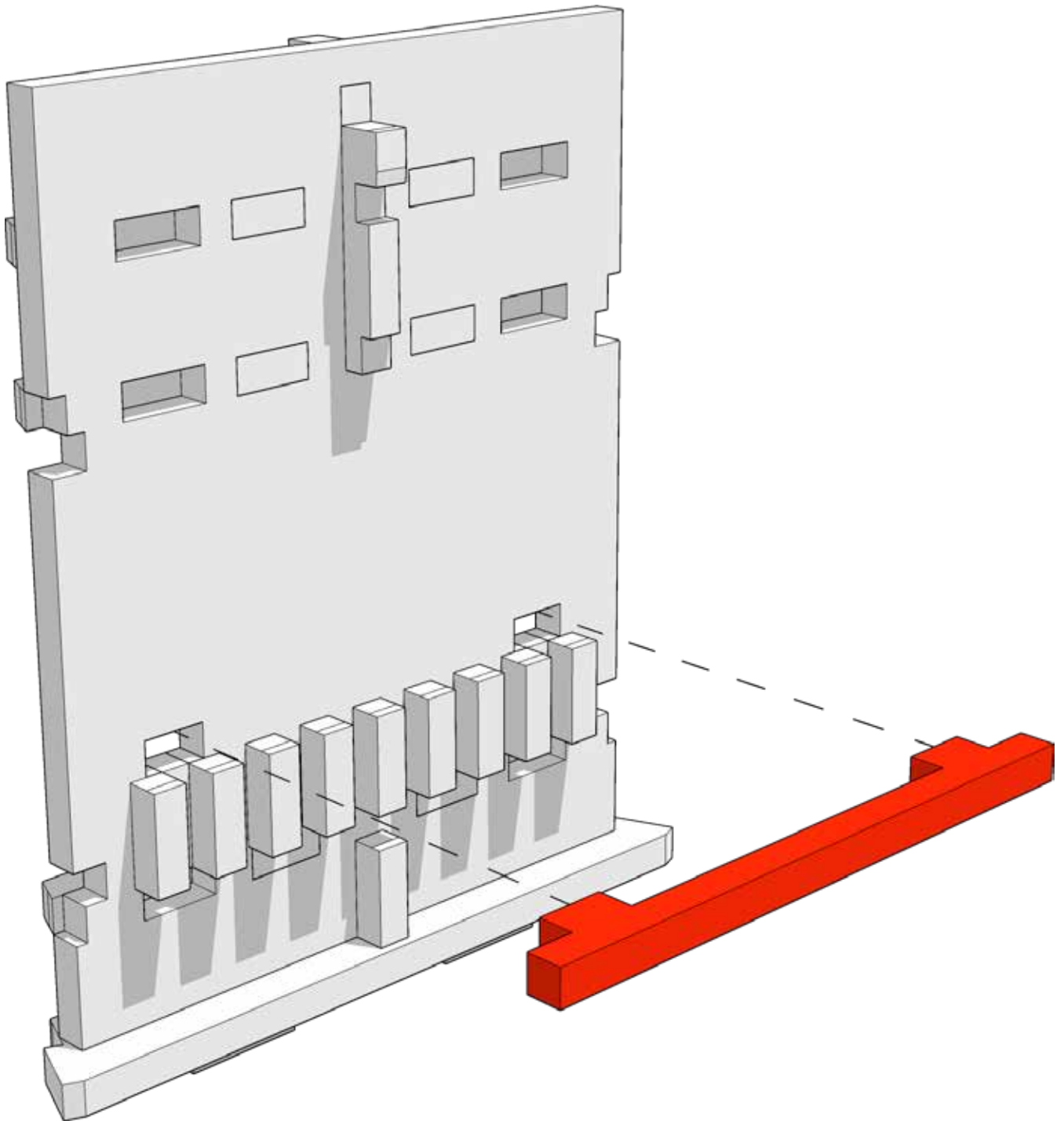



TABLETOP SCENICS

TTSCW-EES-110
Toshi
Hakkei-tō Pagoda

24

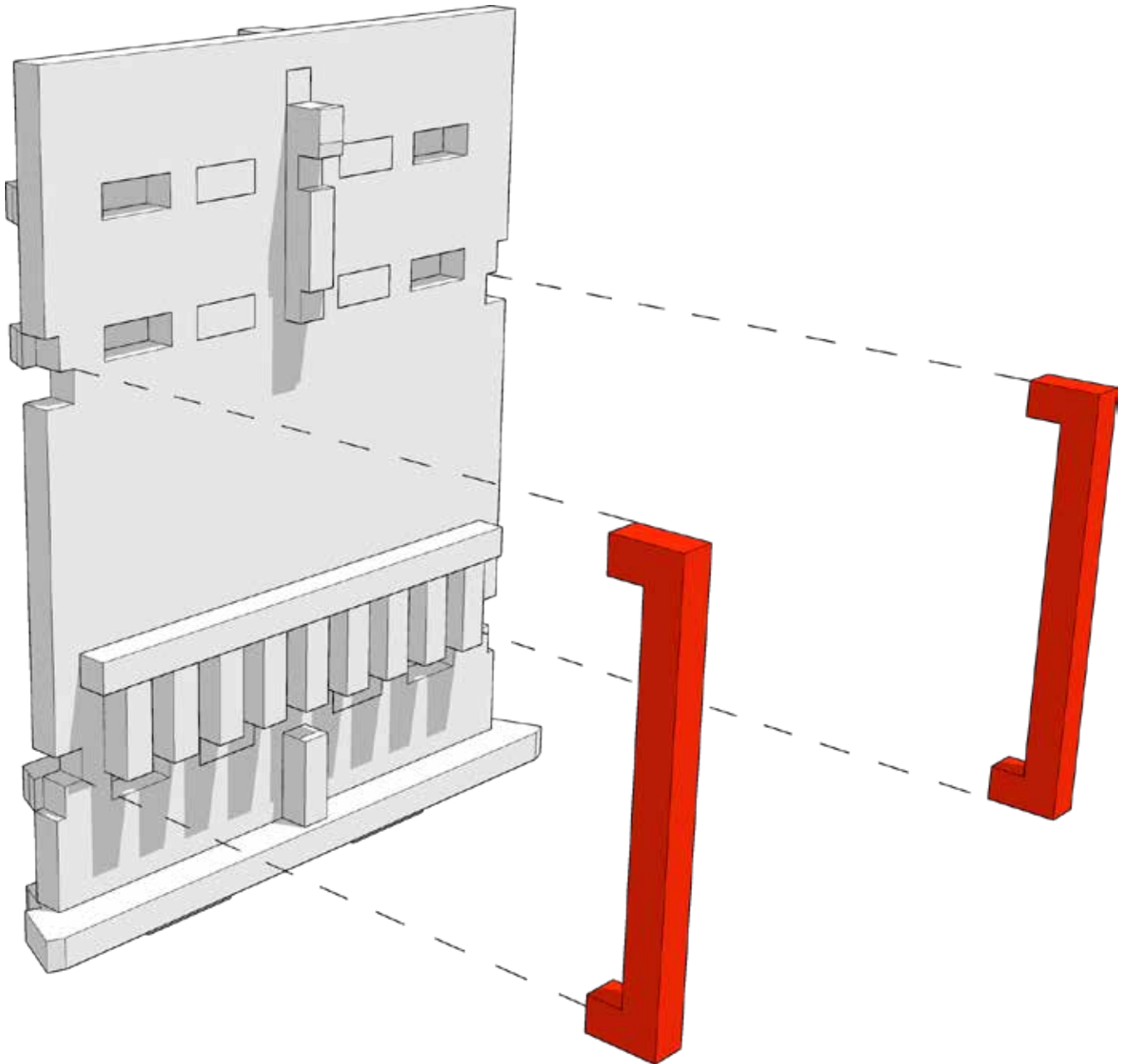



TABLETOP SCENICS

TTSCW-EES-110
Toshi
Hakkei-tō Pagoda

25

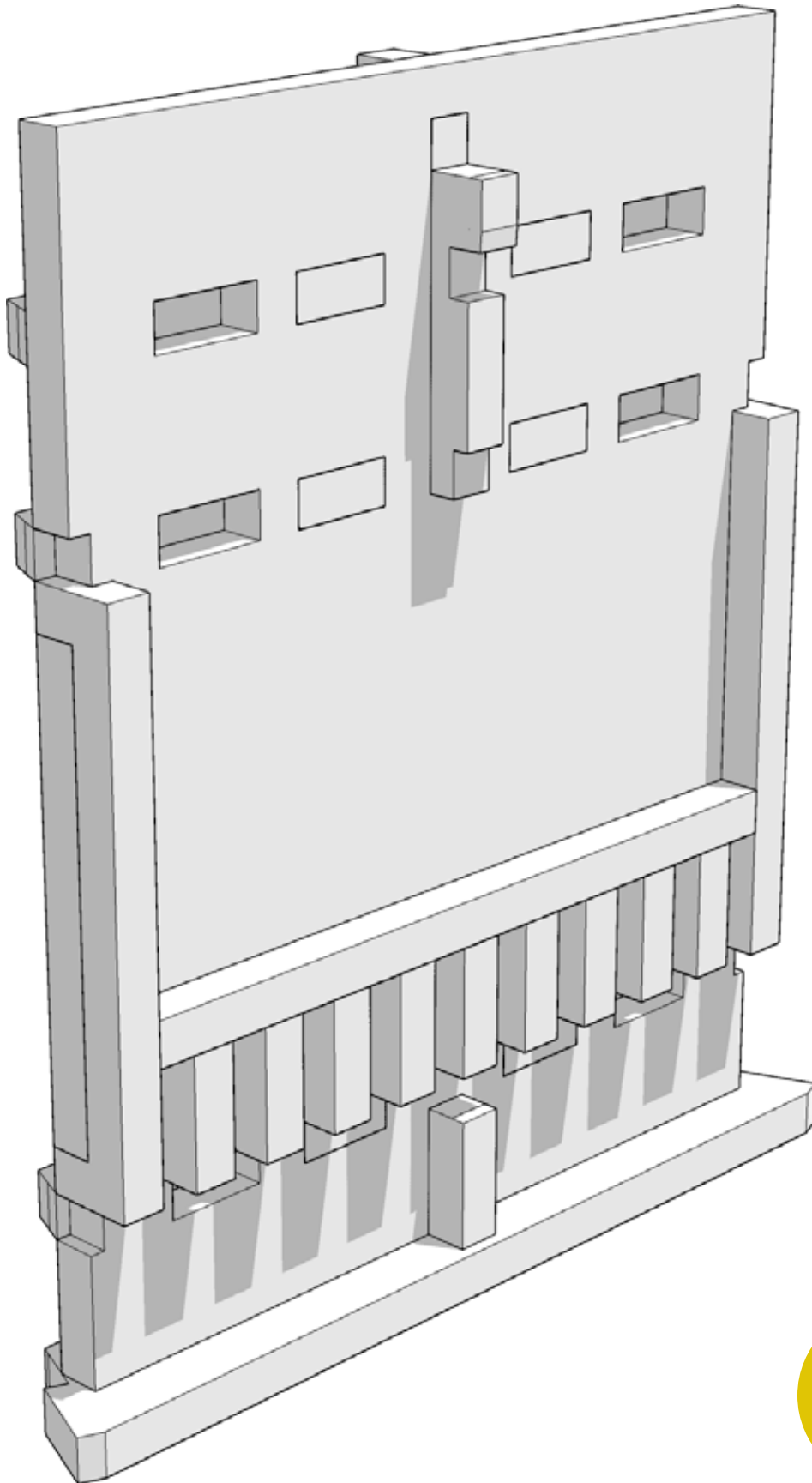

x4



TABLETOP SCENICS

26

TTSCW-EES-110
Toshi
Hakkei-tō Pagoda

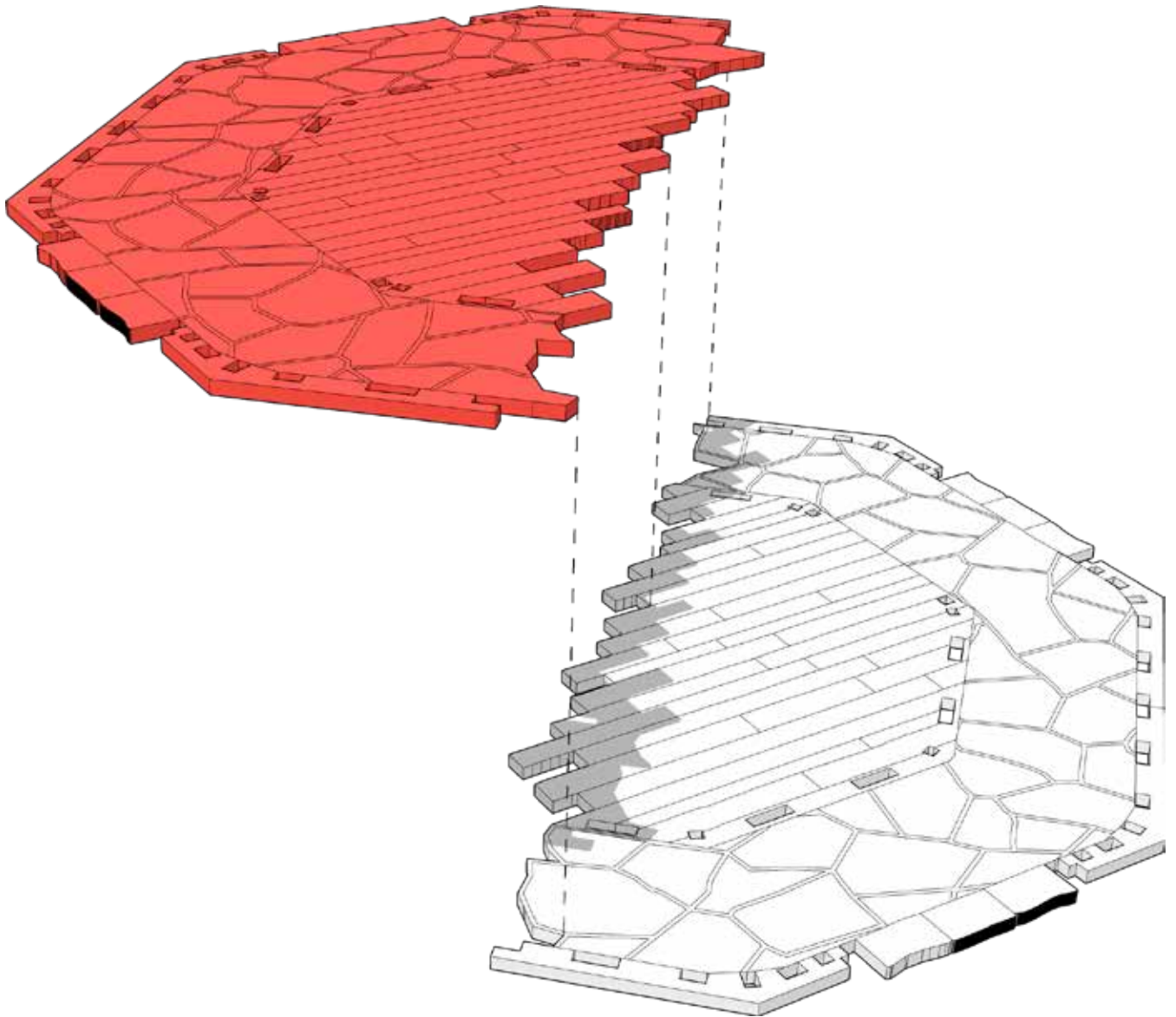



TABLETOP SCENICS

TTSCW-EES-110
Toshi
Hakkei-tō Pagoda

27

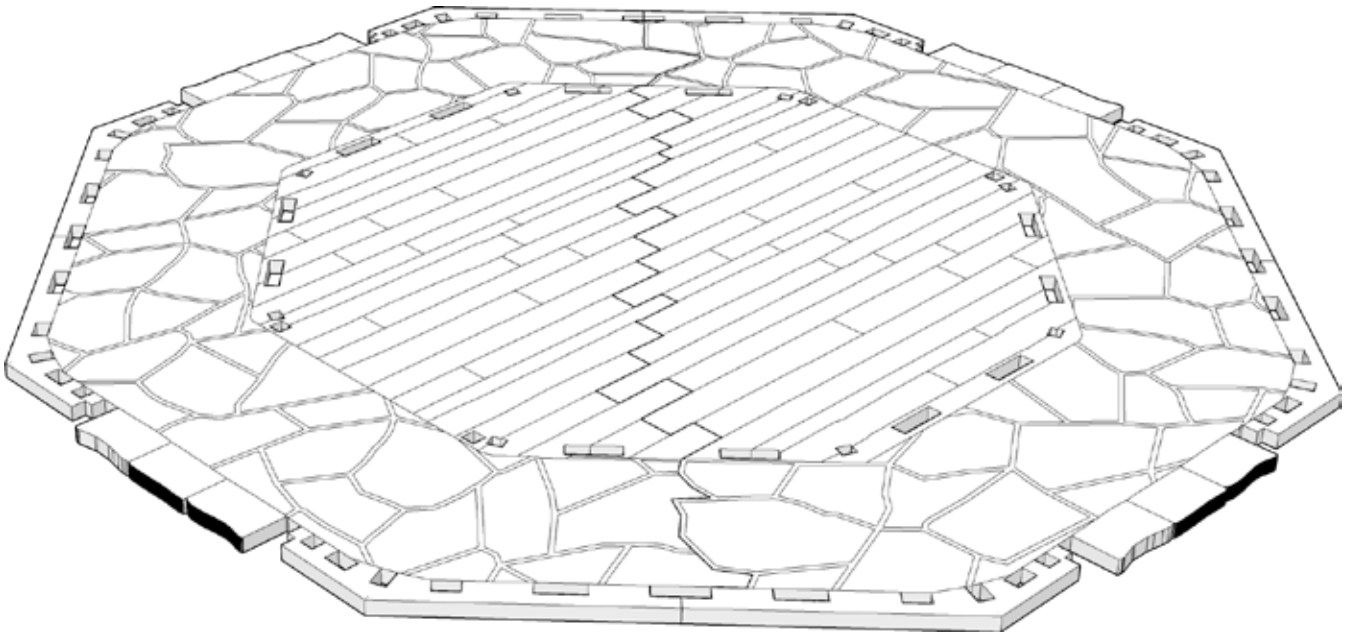



TABLETOP SCENICS

28

TTSCW-EES-110
Toshi
Hakkei-tō Pagoda

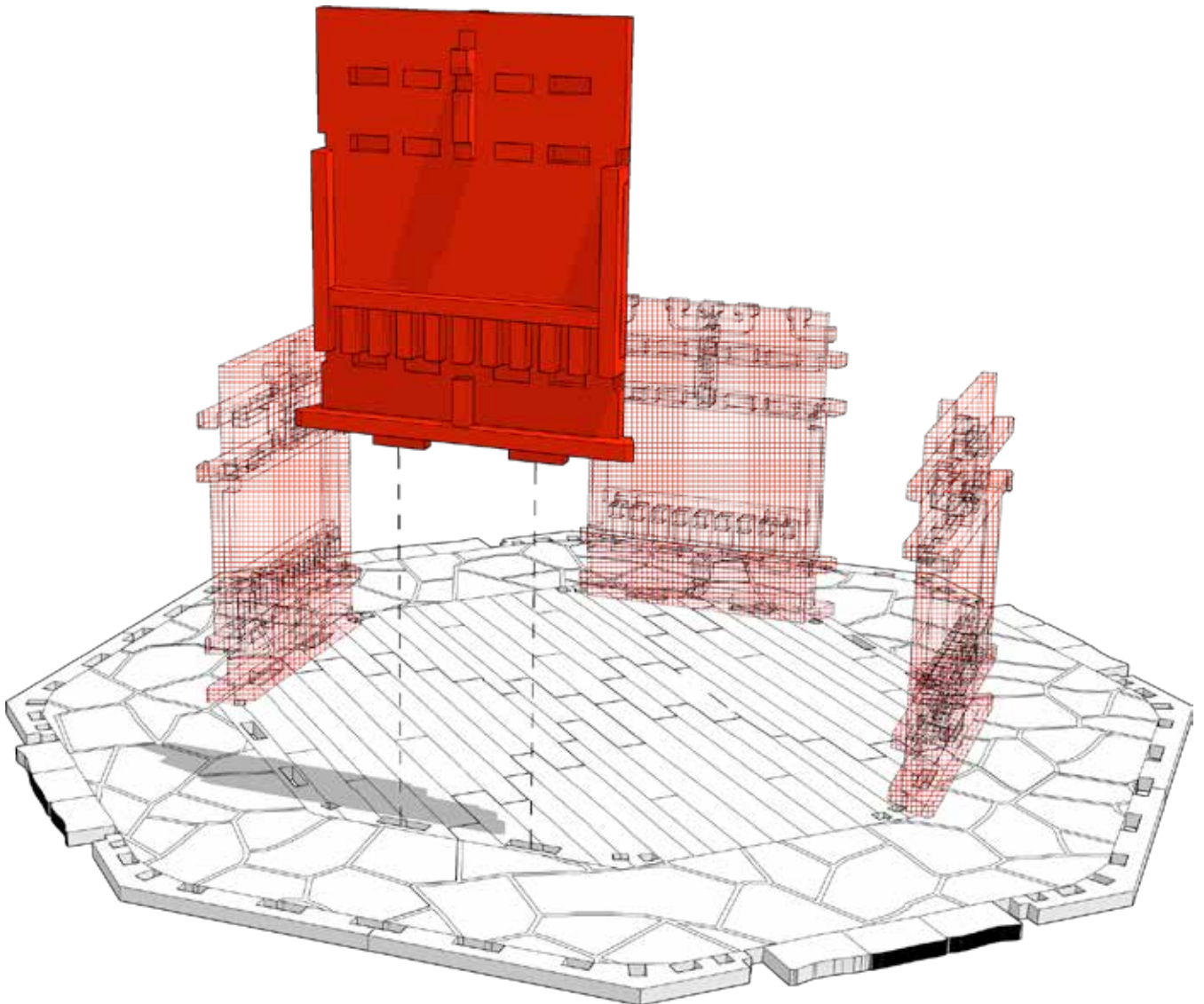



TABLETOP SCENICS

TTSCW-EES-110
Toshi
Hakkei-tō Pagoda

29

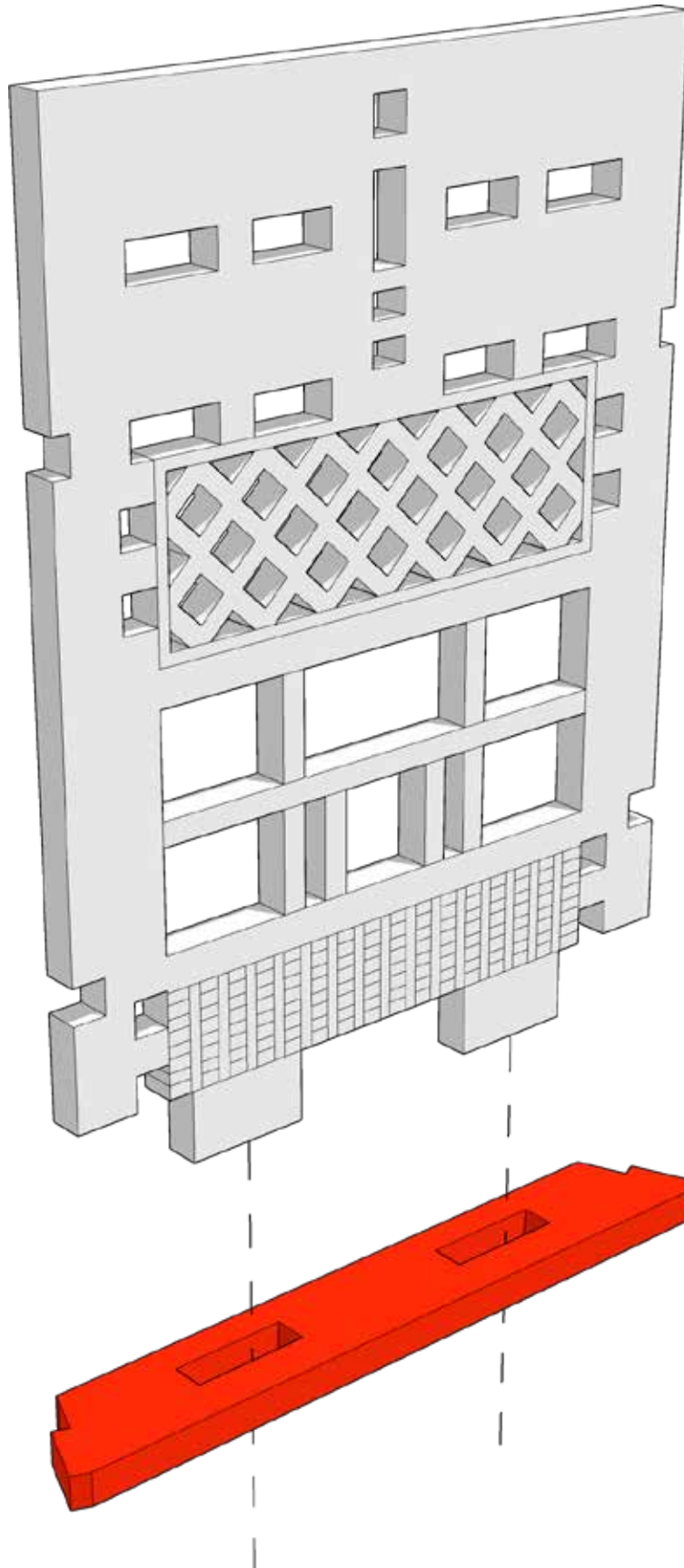



TABLETOP SCENICS

30

TTSCW-EES-110
Toshi
Hakkei-tō Pagoda

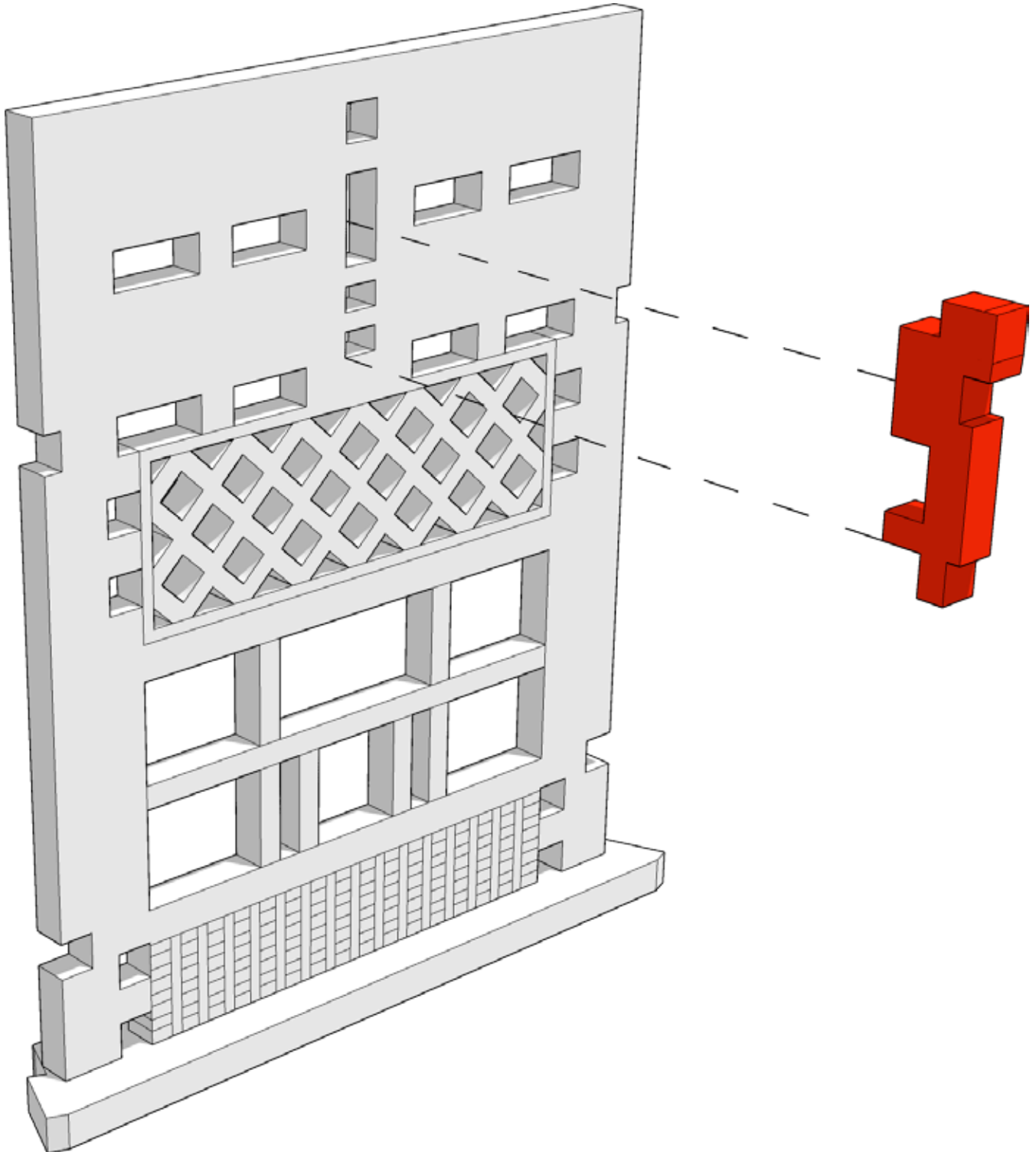



TABLETOP SCENICS

TTSCW-EES-110
Toshi
Hakkei-tō Pagoda

31

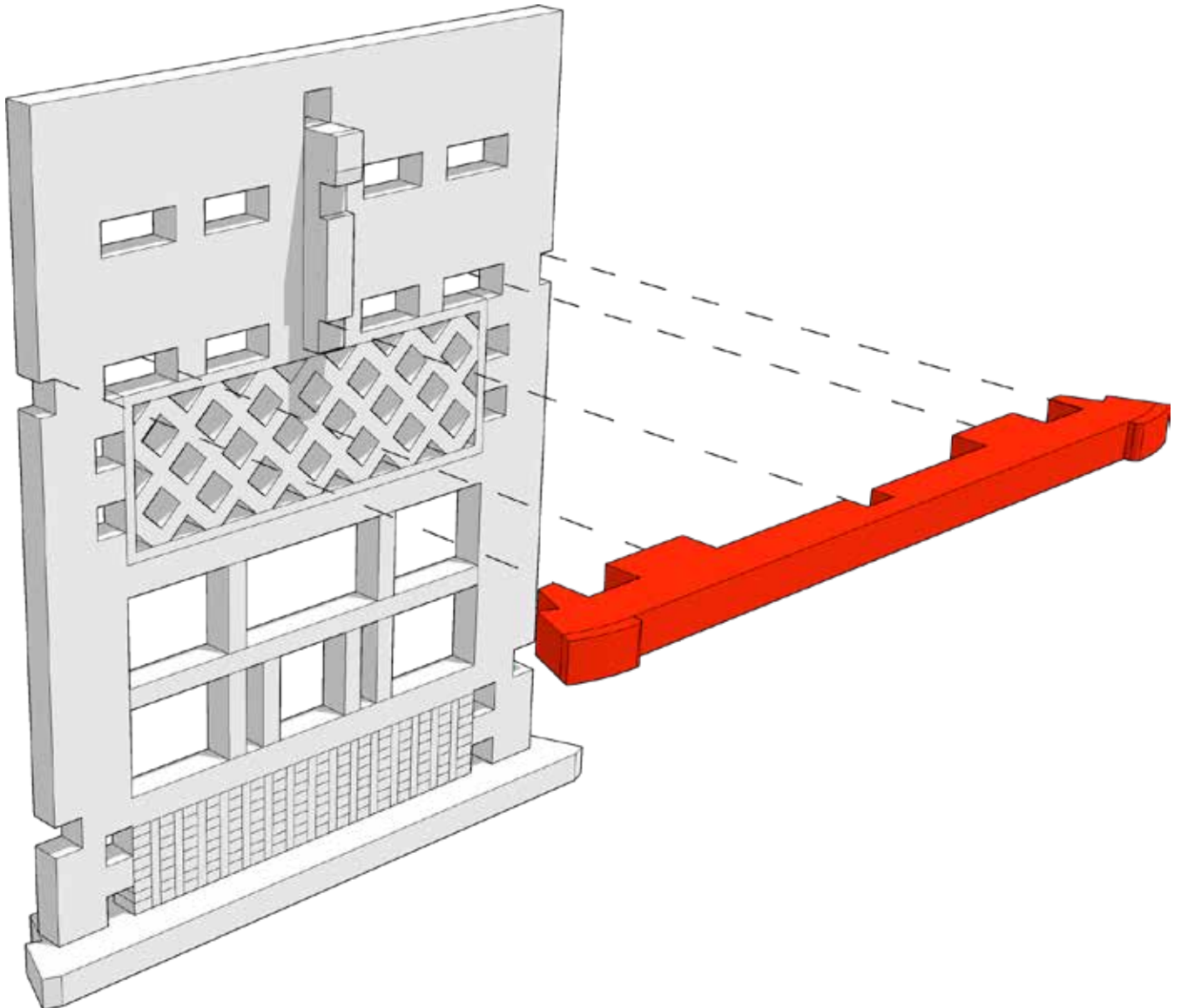



TABLETOP SCENICS

TTSCW-EES-110
Toshi
Hakkei-tō Pagoda

32

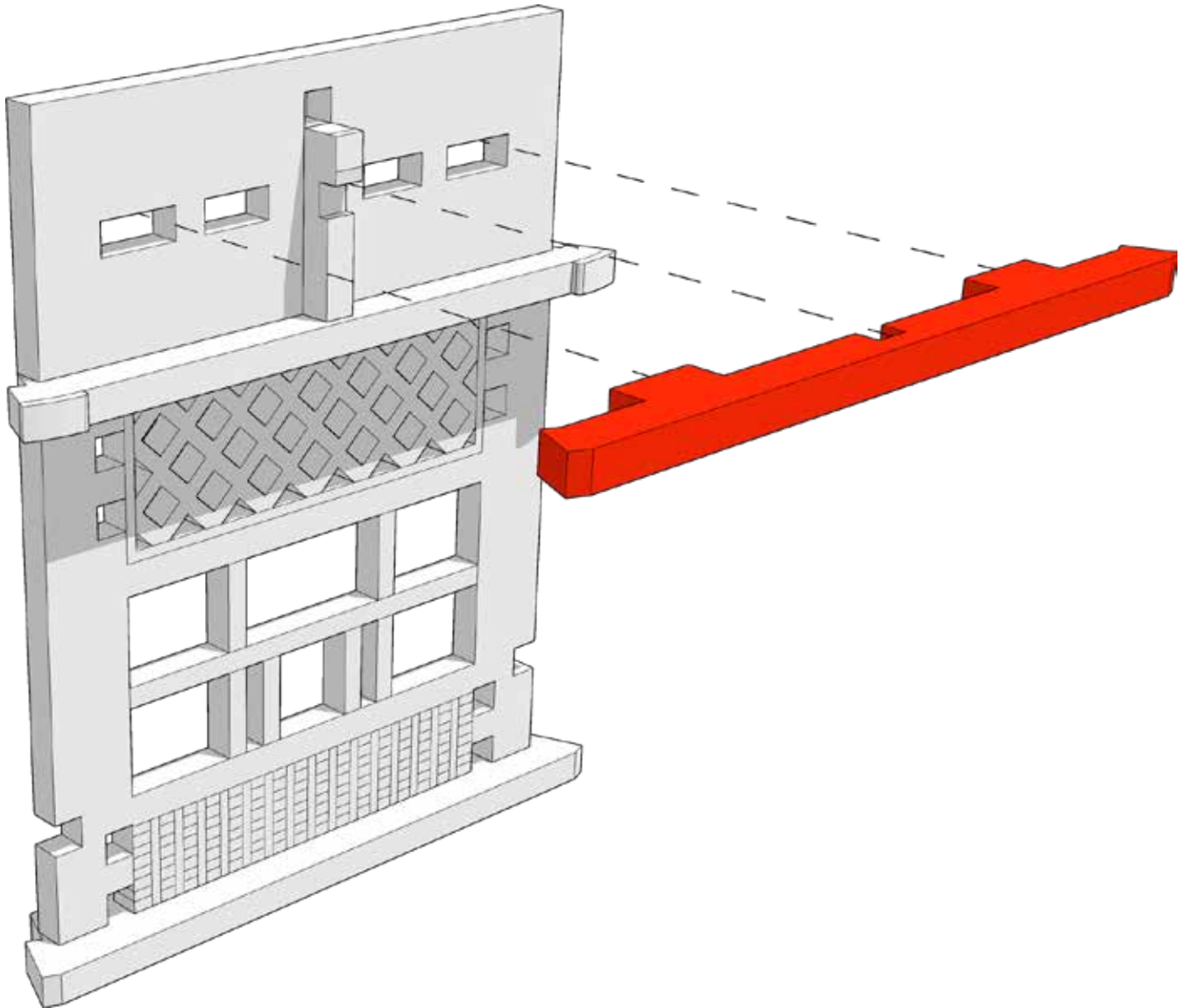



TABLETOP SCENICS

TTSCW-EES-110
Toshi
Hakkei-tō Pagoda

33

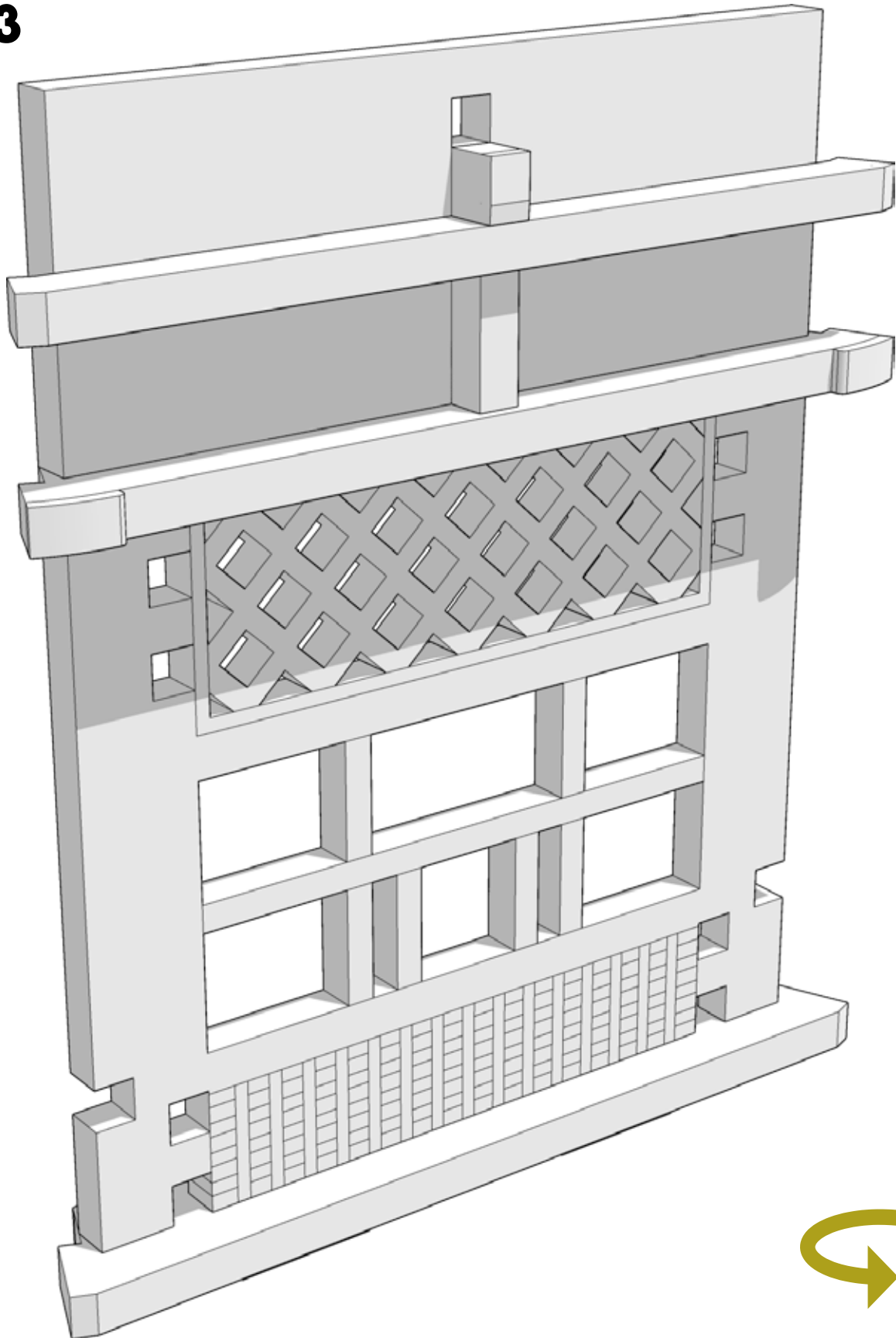



TABLETOP SCENICS

TTSCW-EES-110
Toshi
Hakkei-tō Pagoda

34

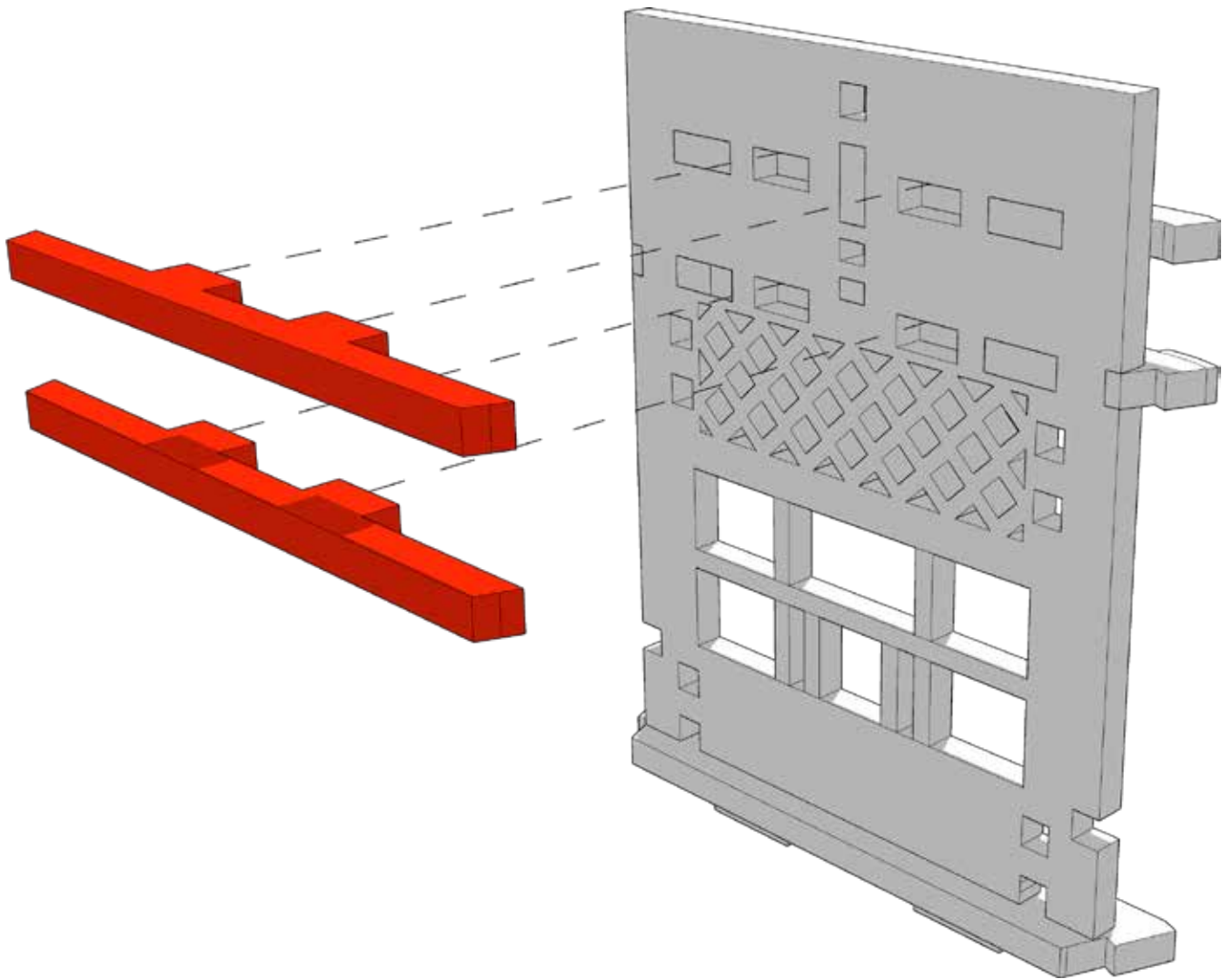



TABLETOP SCENICS

TTSCW-EES-110
Toshi
Hakkei-tō Pagoda

35

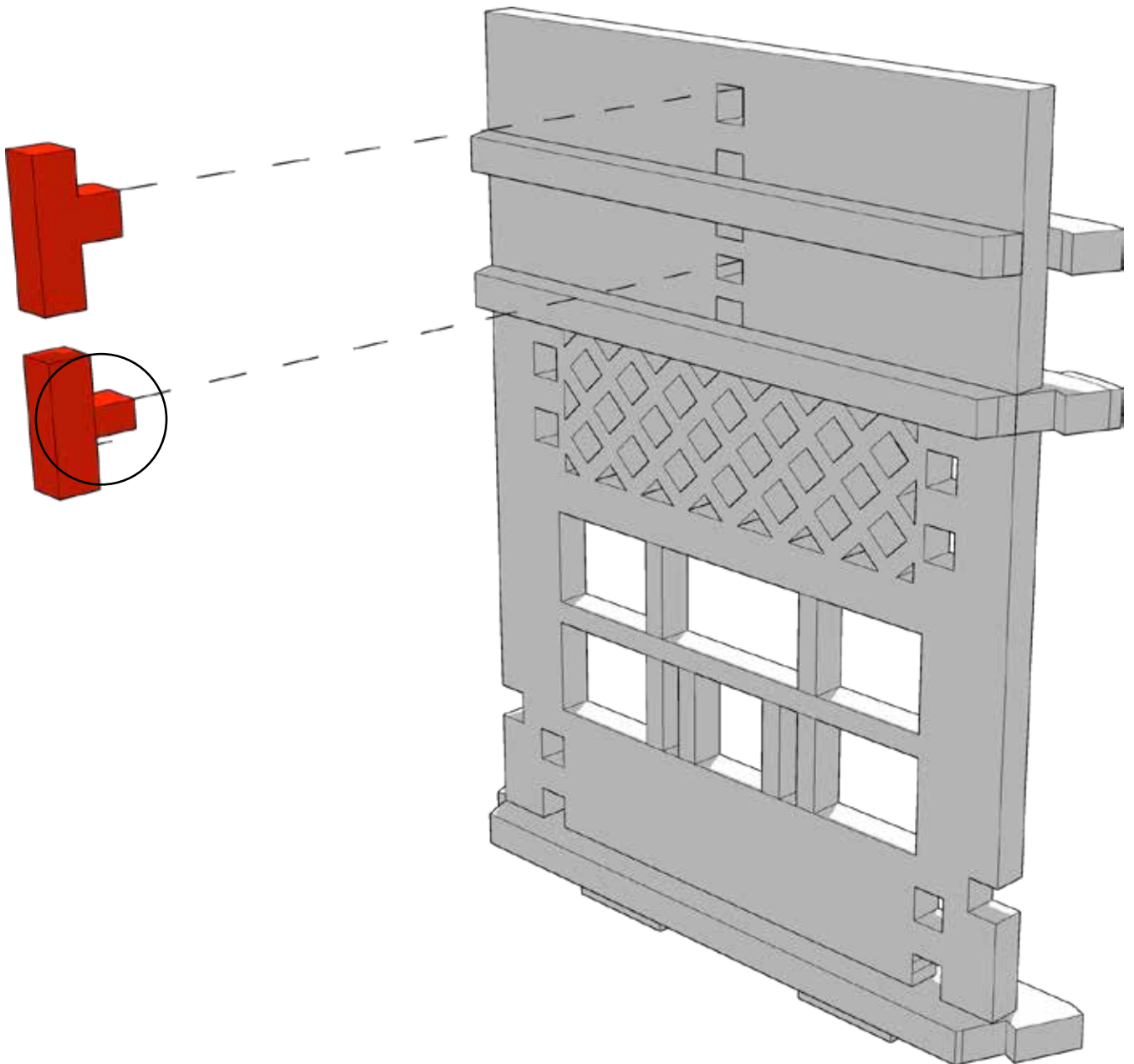

Circled part has a smaller tab than the one above and is labeled "B" on the sprues. The other is labeled "C"



 **TTCOMBAT**



TABLETOP SCENICS

TTSCW-EES-110
Toshi
Hakkei-tō Pagoda

36

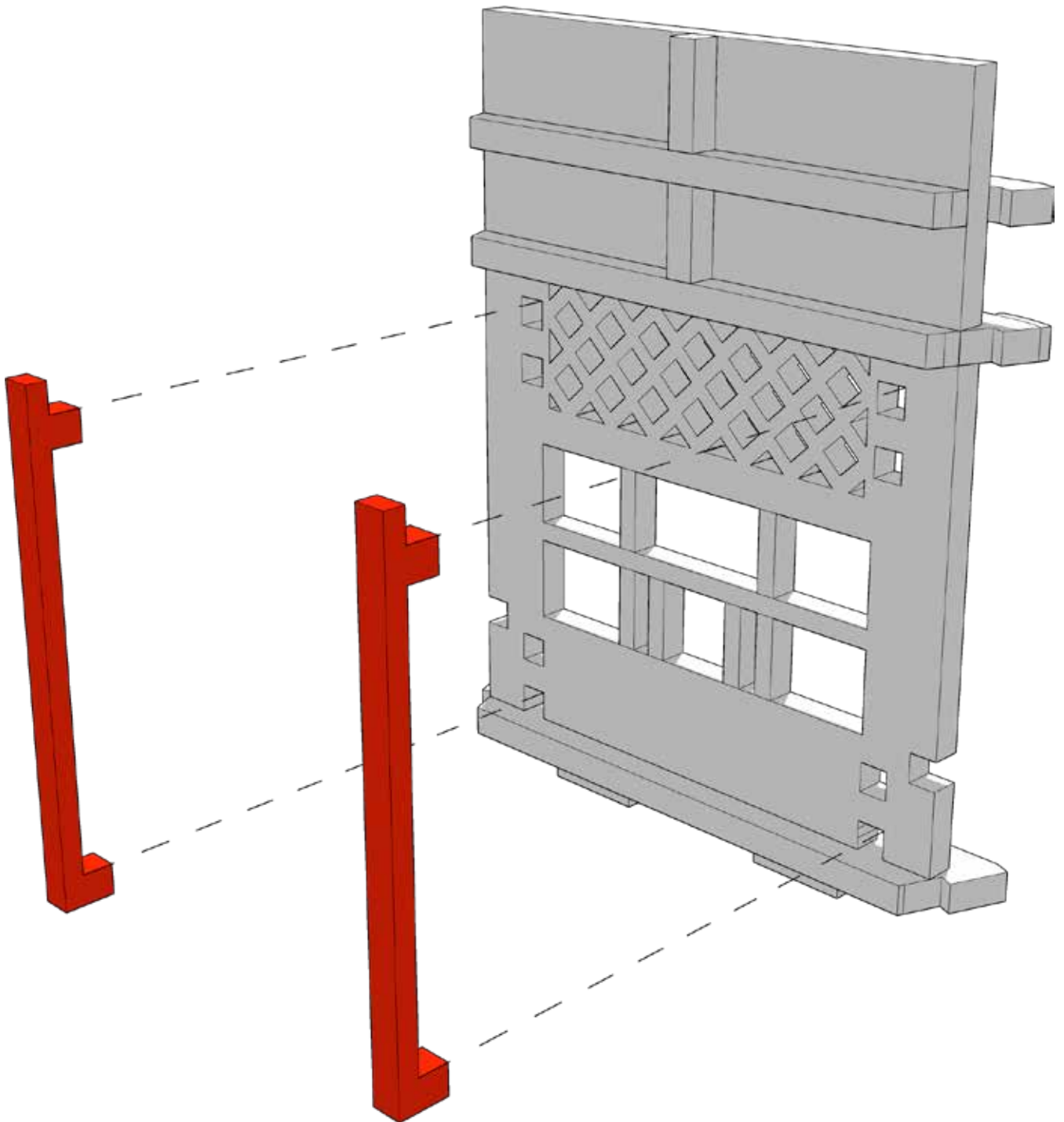



TABLETOP SCENICS

TTSCW-EES-110
Toshi
Hakkei-tō Pagoda

37

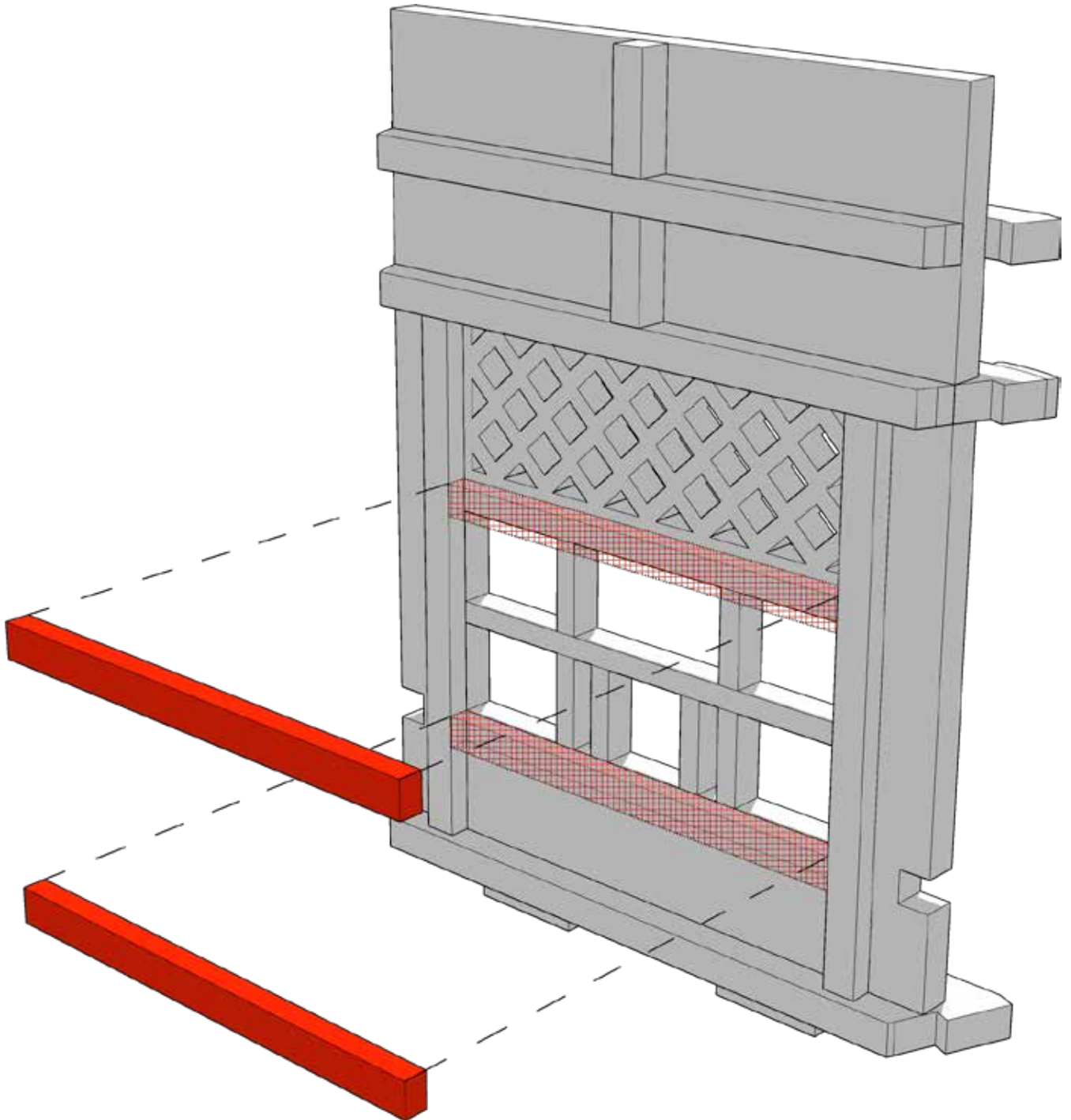



TABLETOP SCENICS

TTSCW-EES-110
Toshi
Hakkei-tō Pagoda

38

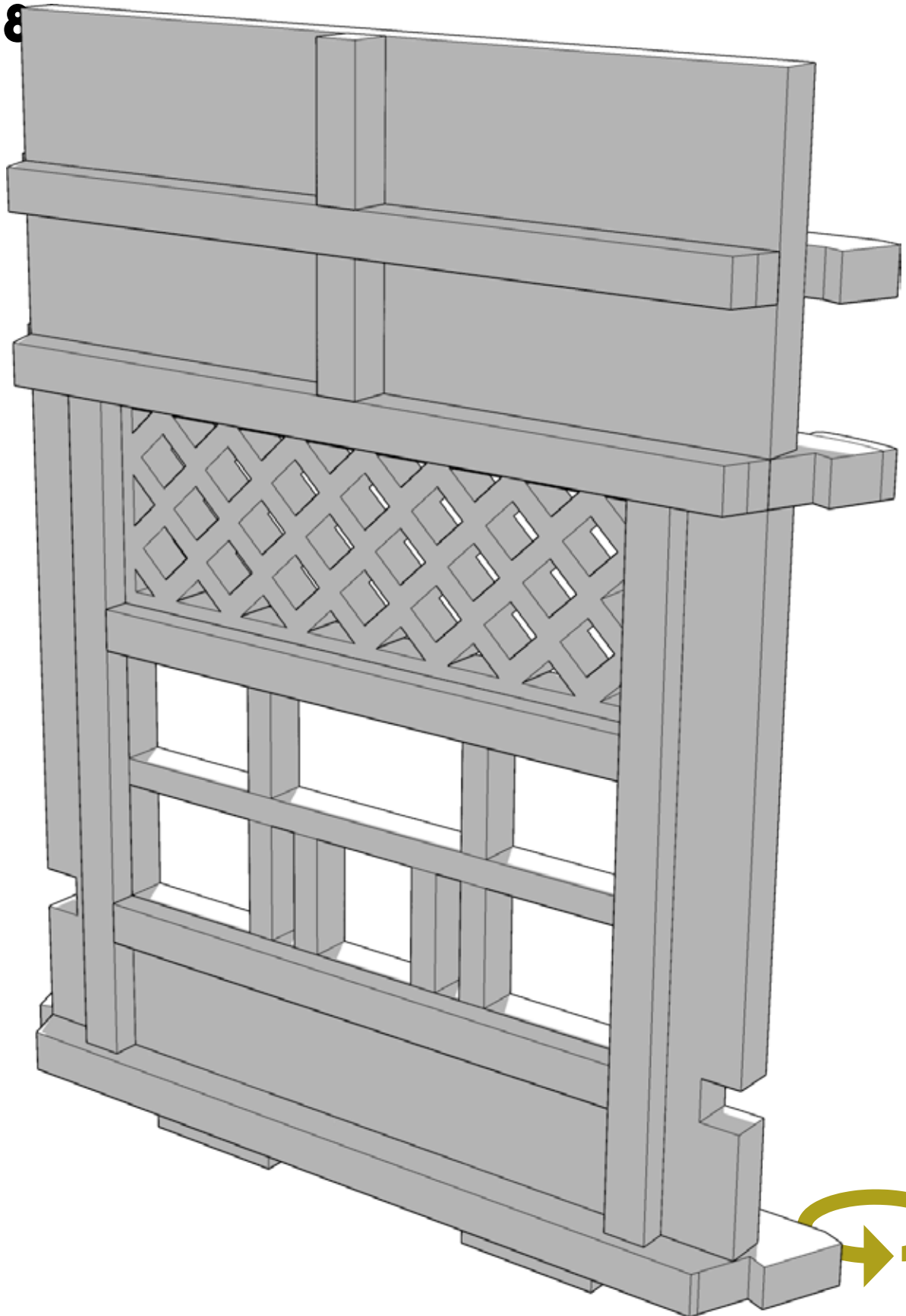



TABLETOP SCENICS

TTSCW-EES-110
Toshi
Hakkei-tō Pagoda

39

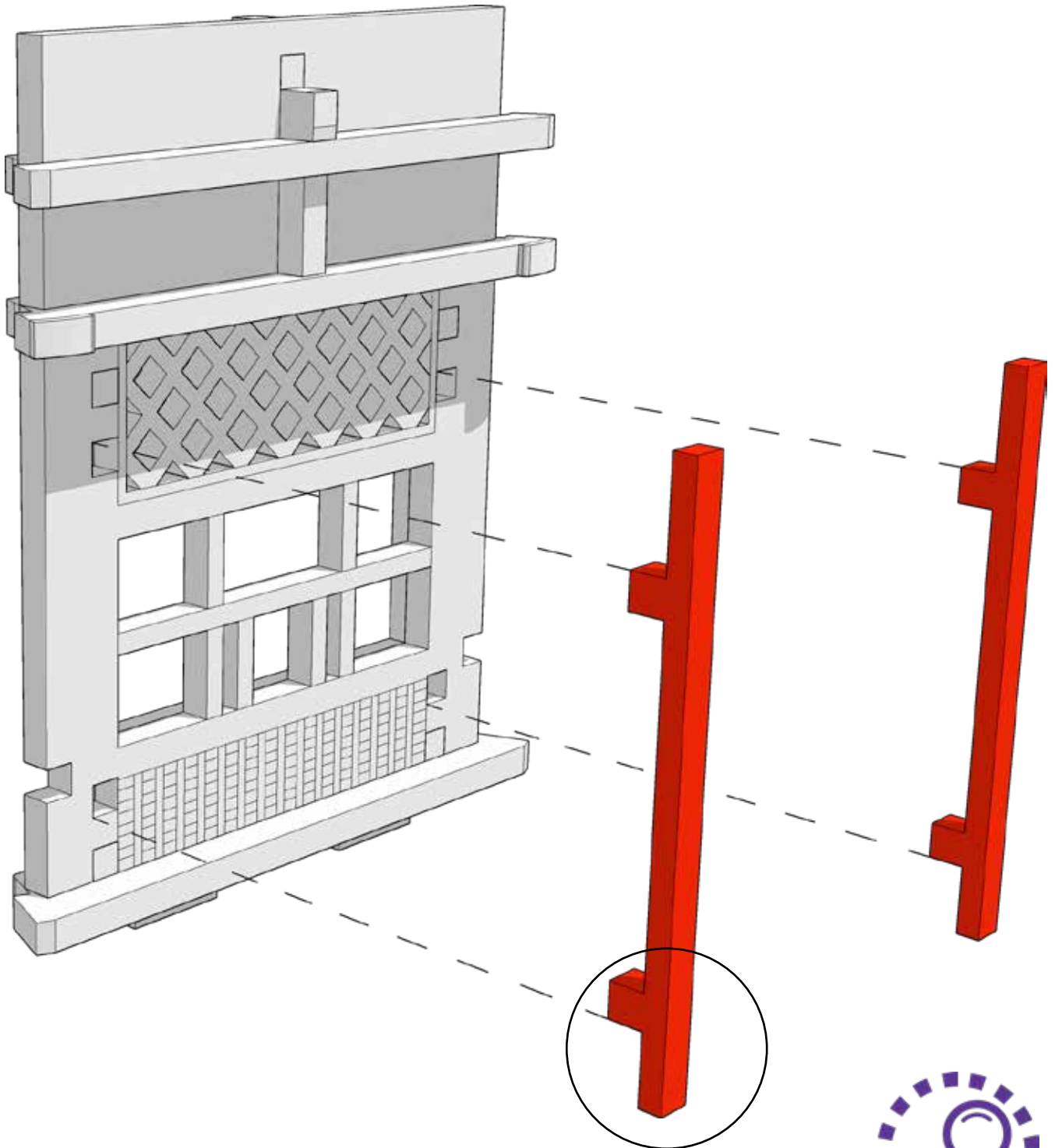

Highlighted parts are shorter one side which goes at the bottom



 TTCOMBAT



TABLETOP SCENICS

TTSCW-EES-110
Toshi
Hakkei-tō Pagoda

40

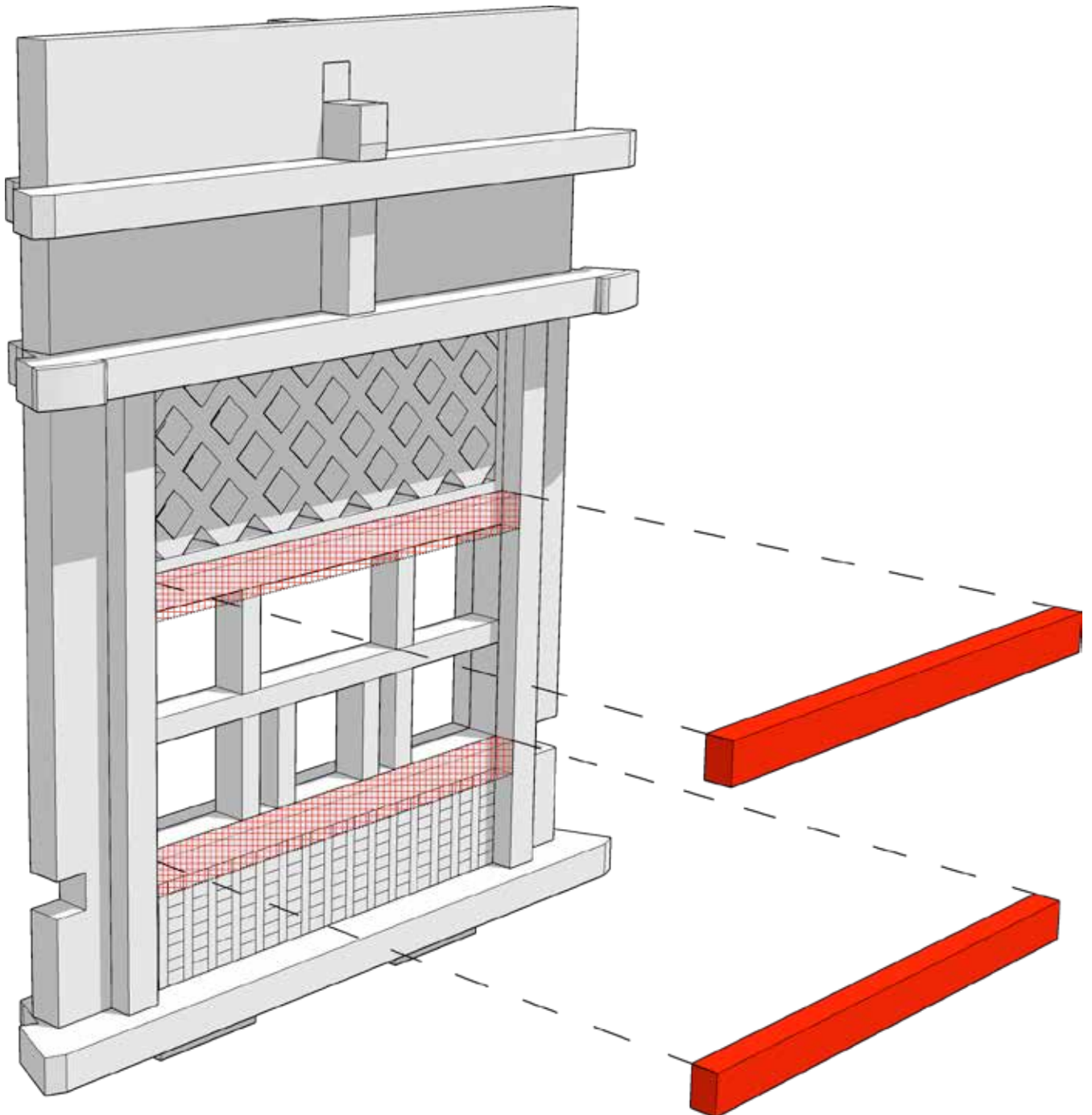



TABLETOP SCENICS

TTSCW-EES-110
Toshi
Hakkei-tō Pagoda

41

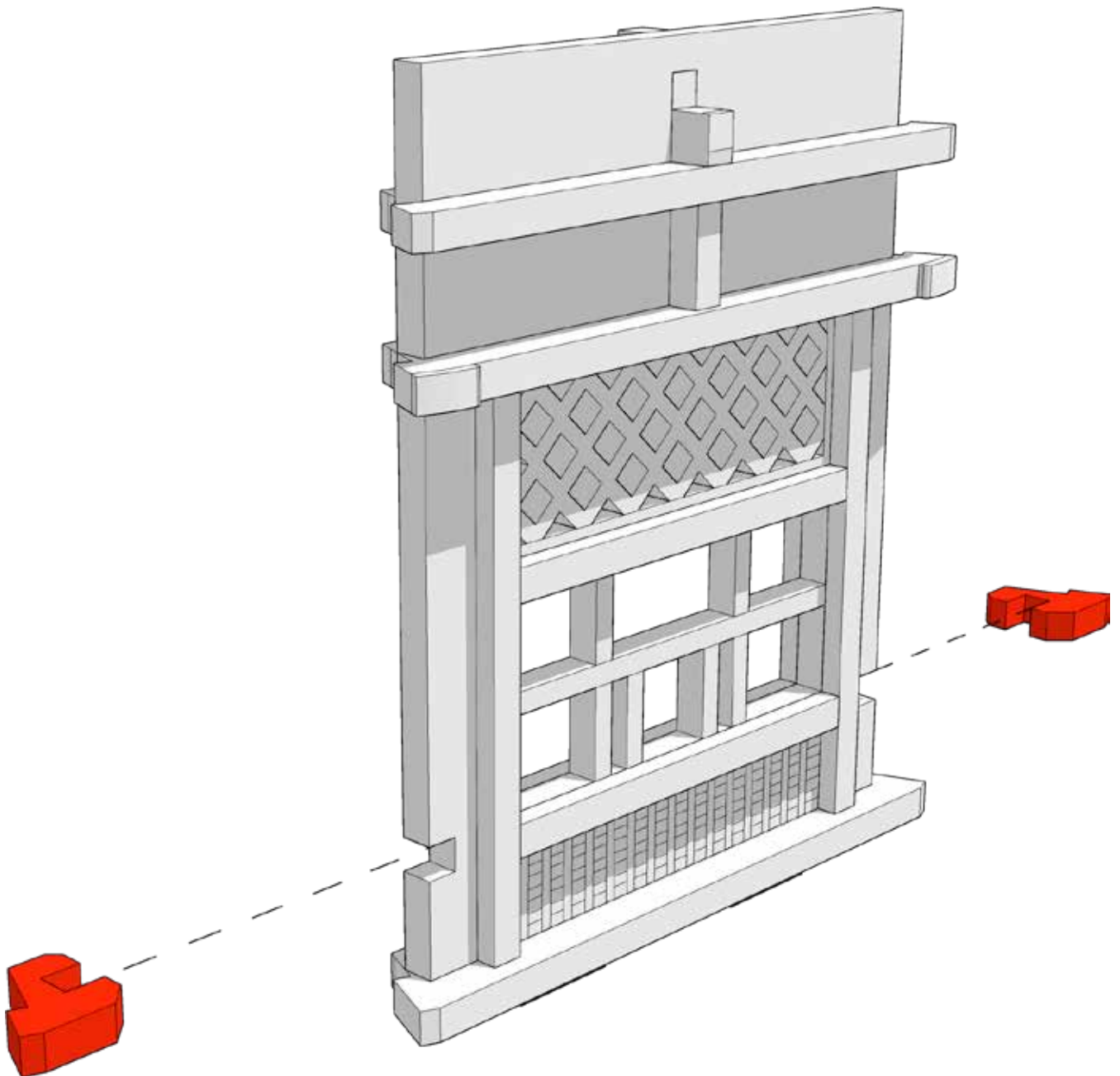

There are similar parts. The red highlighted one is required for the step shown on this page. Found on Sheet 6 of the sprues



TABLETOP SCENICS

TTSCW-EES-110
Toshi
Hakkei-tō Pagoda

42

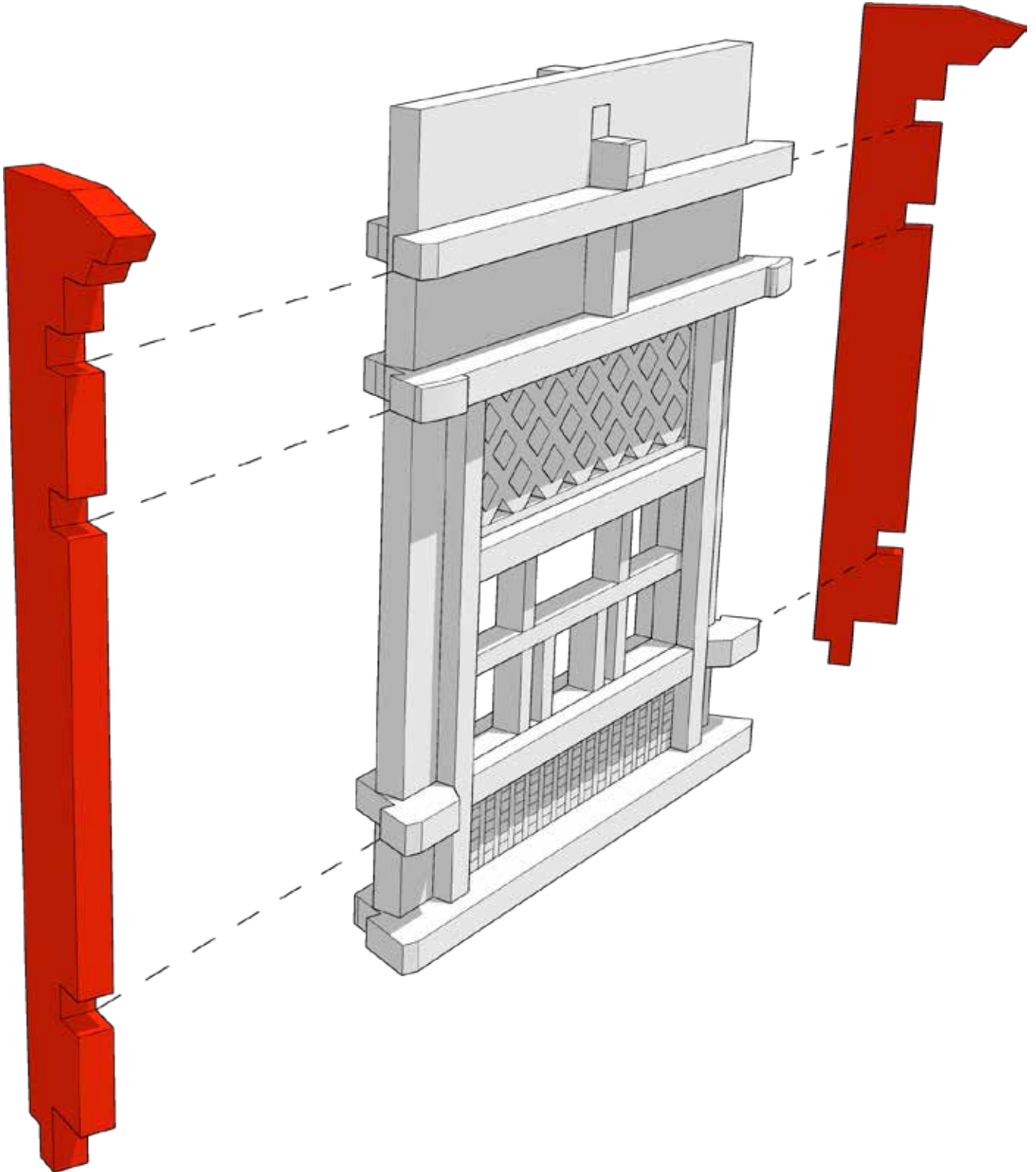



TABLETOP SCENICS

TTSCW-EES-110
Toshi
Hakkei-tō Pagoda

43

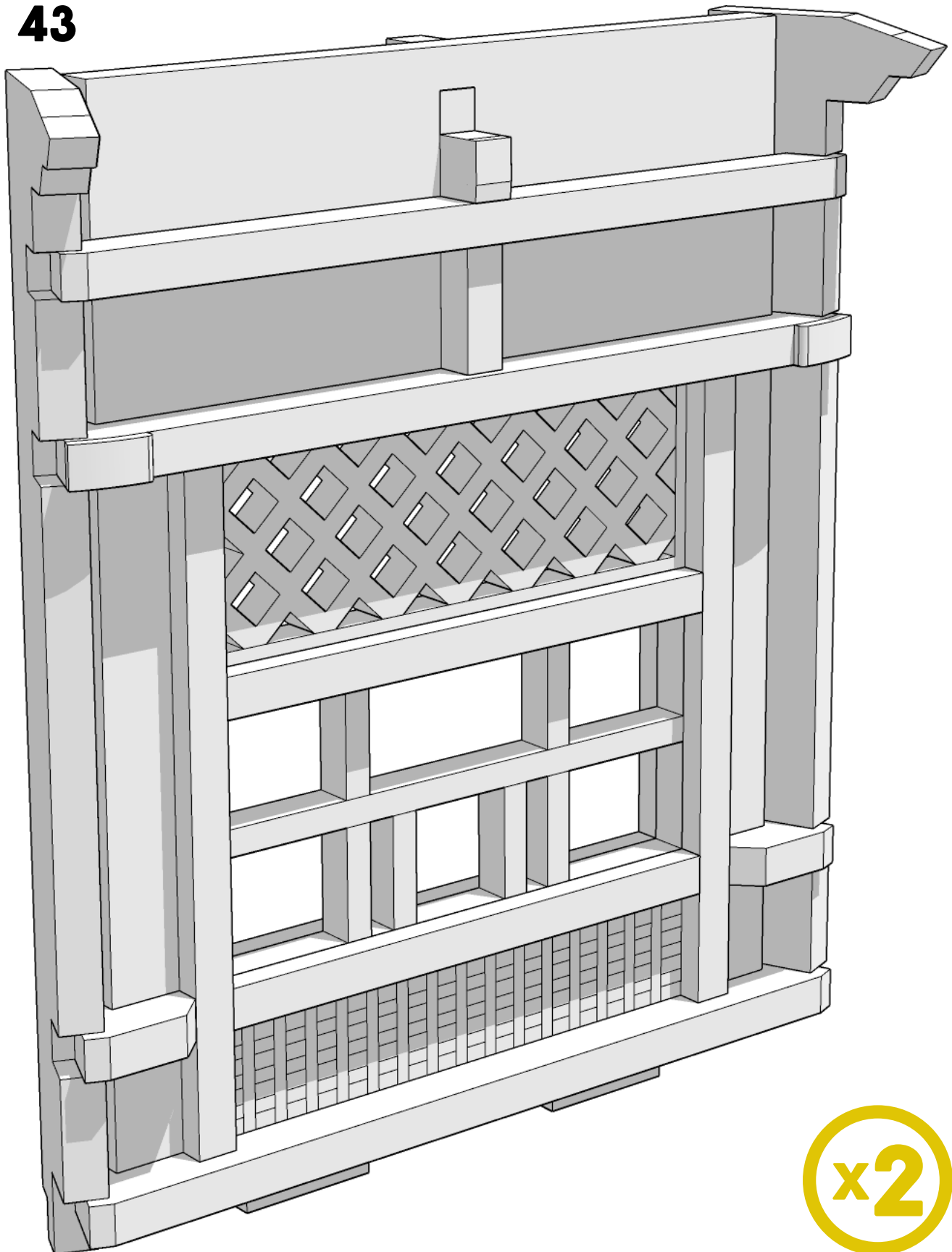

x2



TABLETOP SCENICS

TTSCW-EES-110
Toshi
Hakkei-tō Pagoda

44

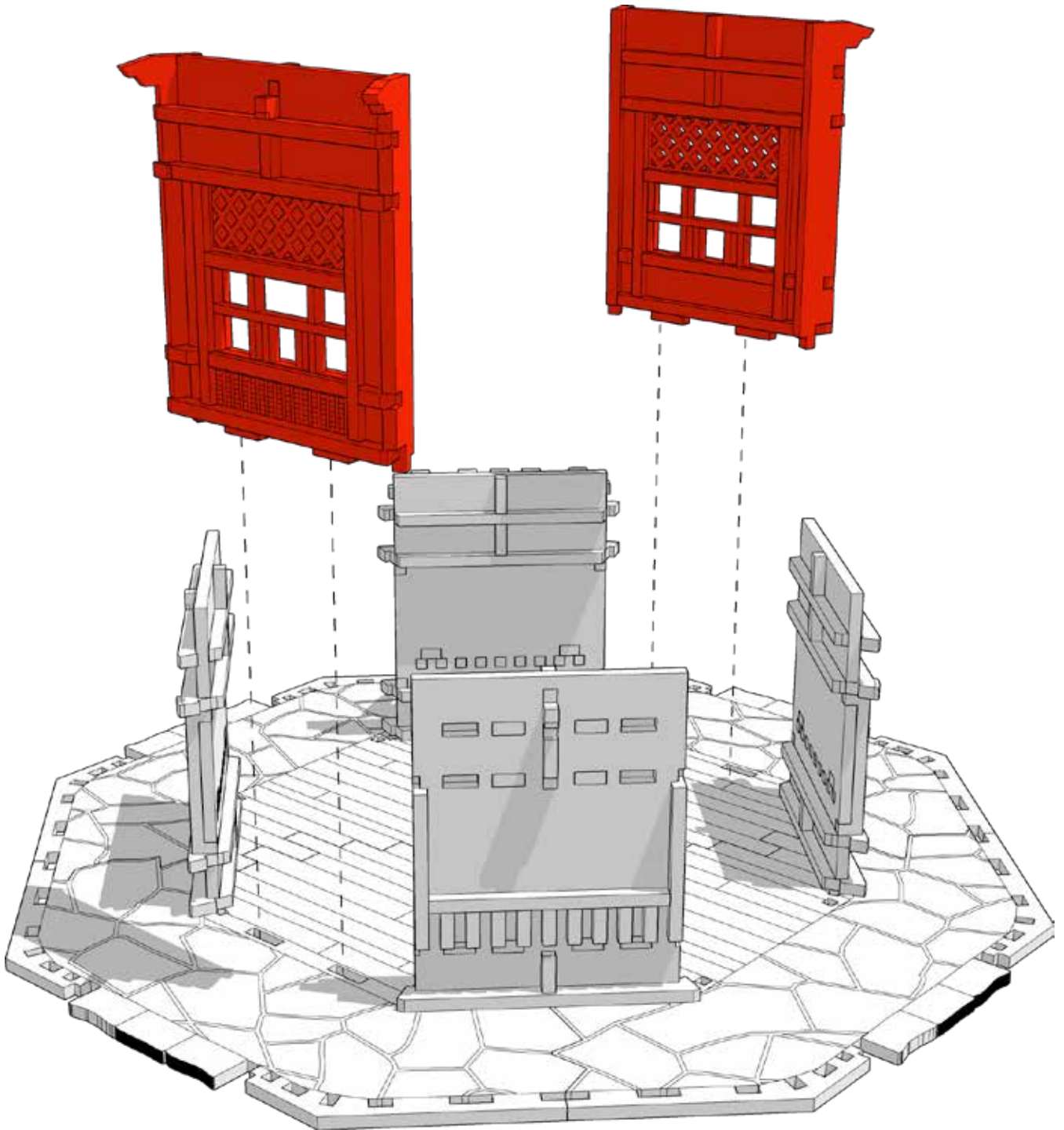



TABLETOP SCENICS

TTSCW-EES-110
Toshi
Hakkei-tō Pagoda

45

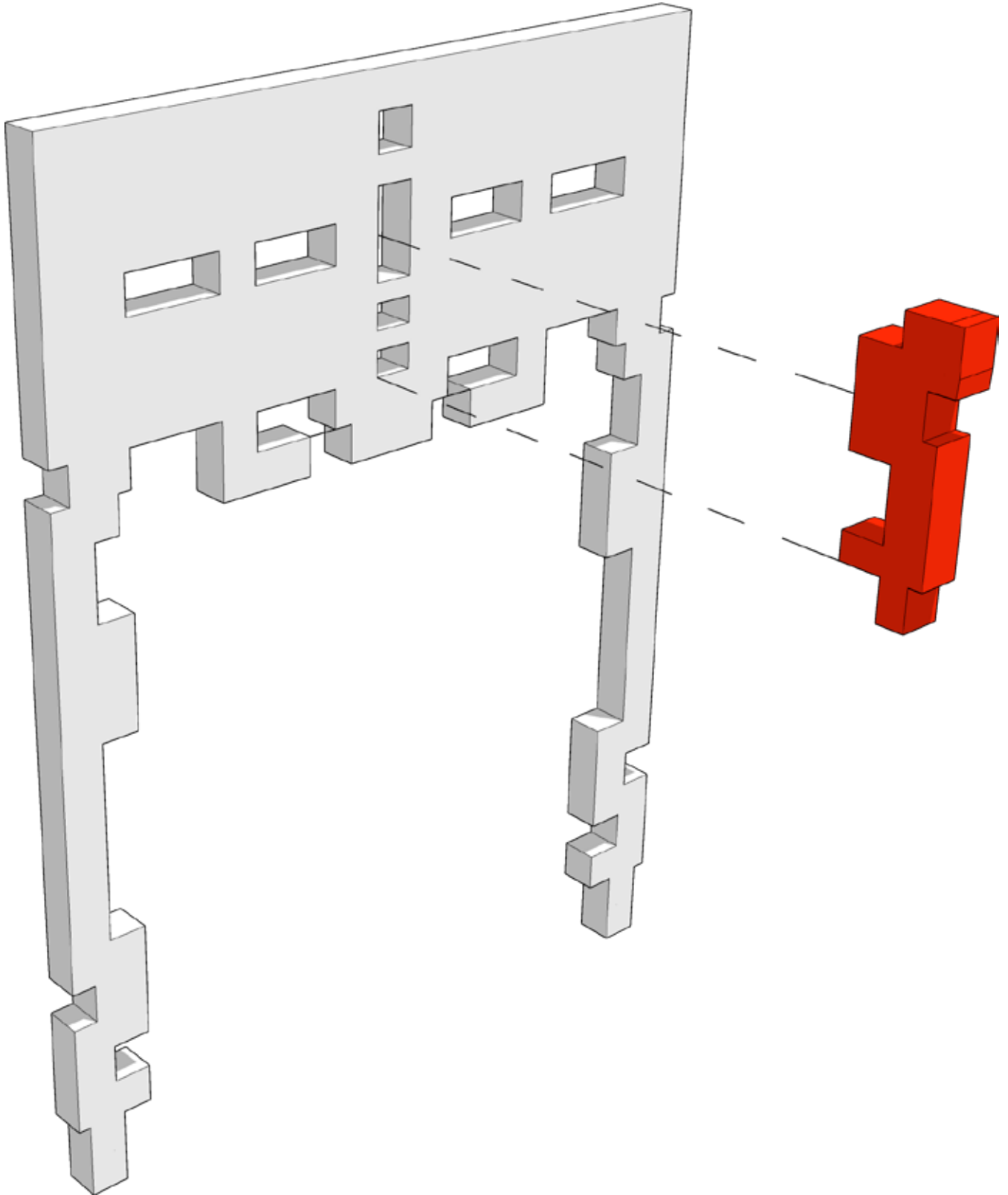



TABLETOP SCENICS

TTSCW-EES-110
Toshi
Hakkei-tō Pagoda

46

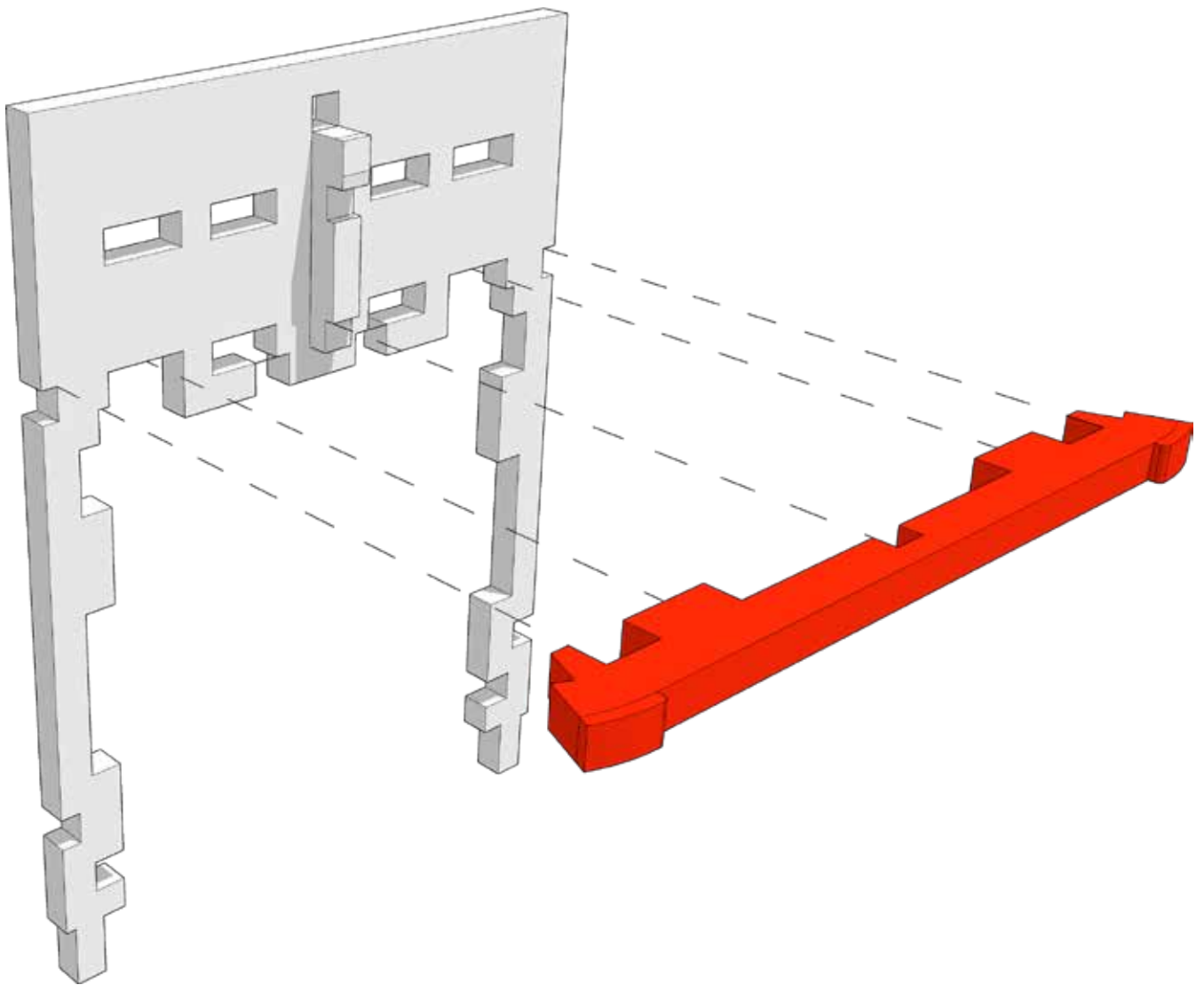



TABLETOP SCENICS

TTSCW-EES-110
Toshi
Hakkei-tō Pagoda

47

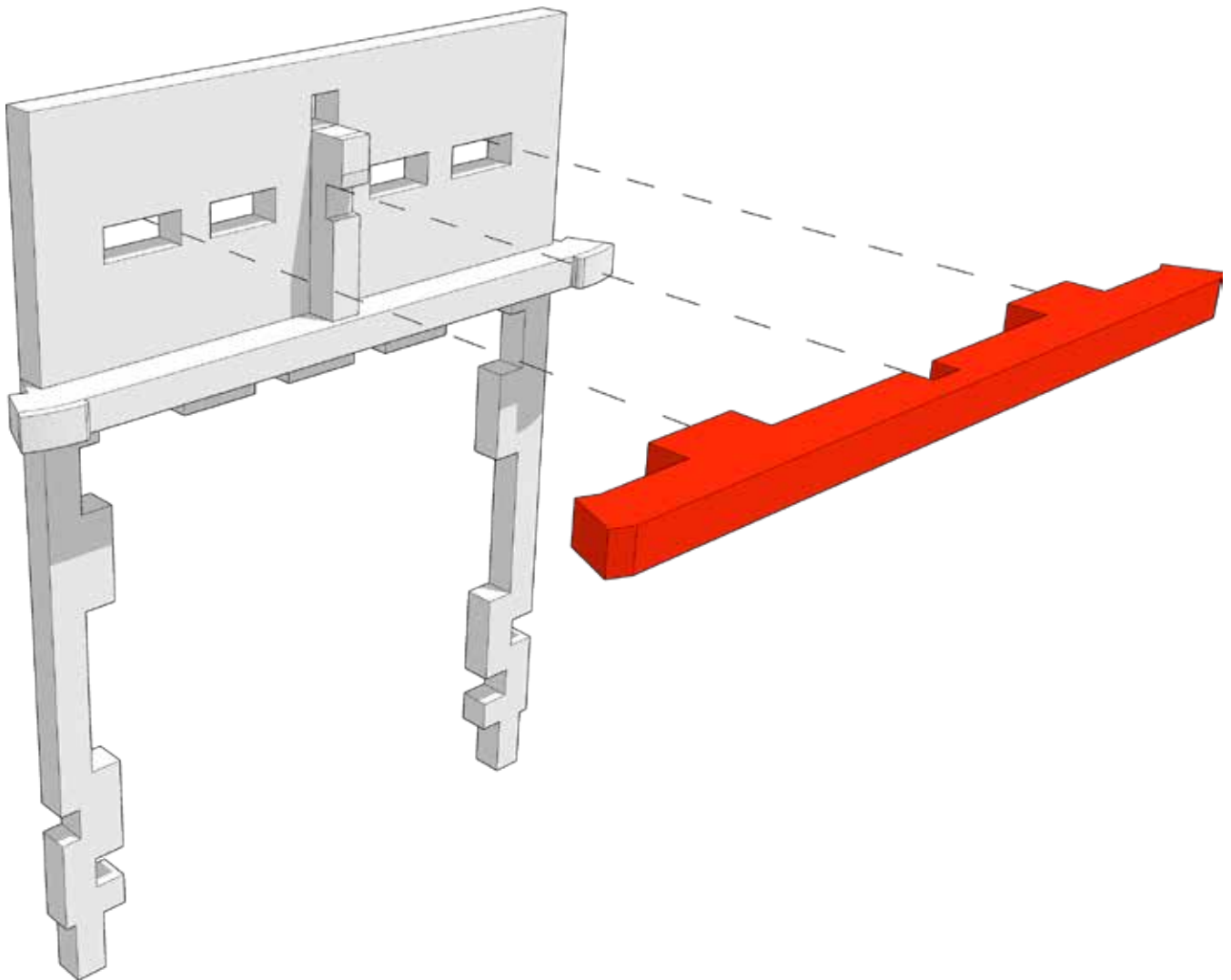



TABLETOP SCENICS

TTSCW-EES-110
Toshi
Hakkei-tō Pagoda

48

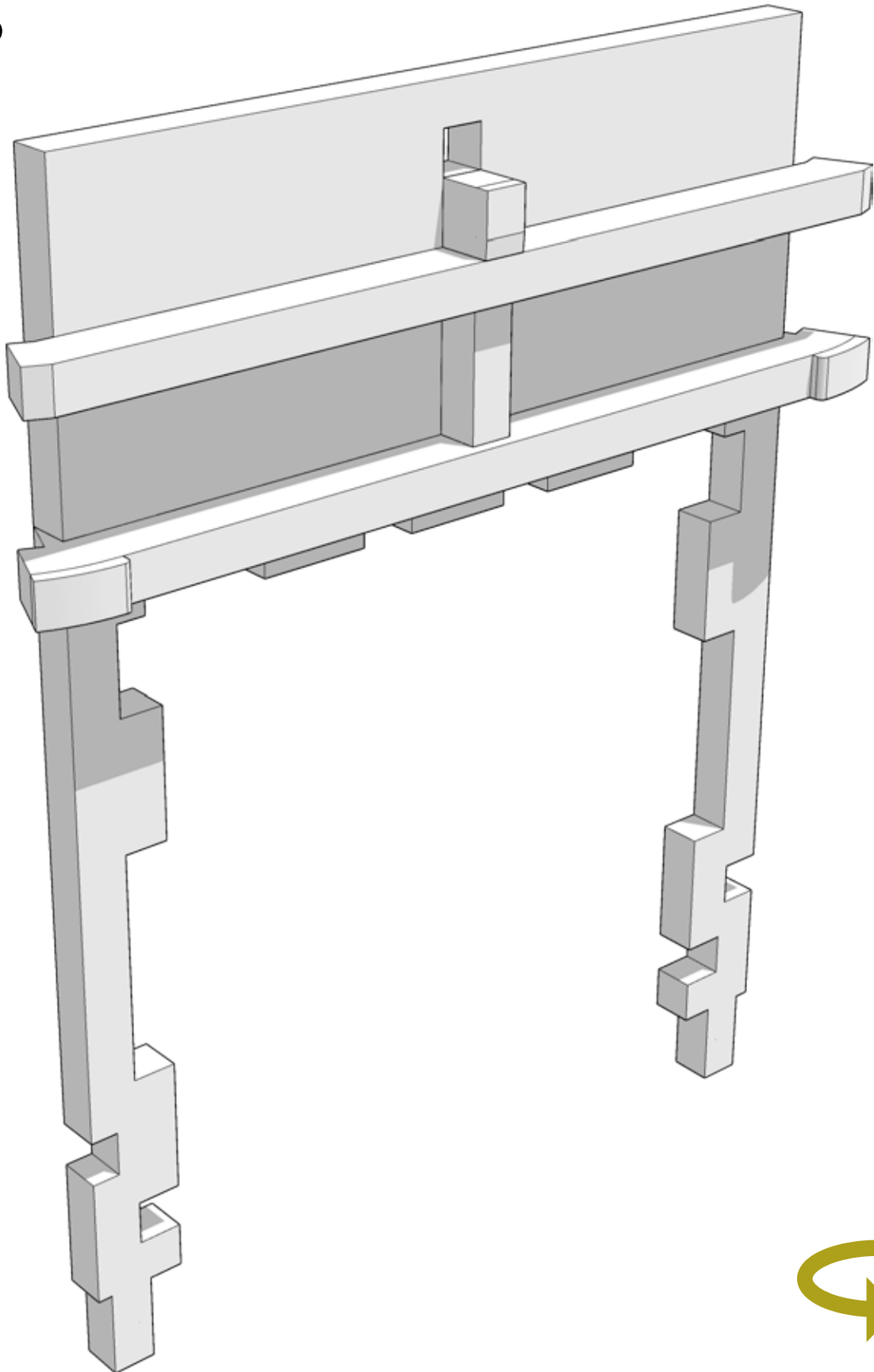



TABLETOP SCENICS

TTSCW-EES-110
Toshi
Hakkei-tō Pagoda

49

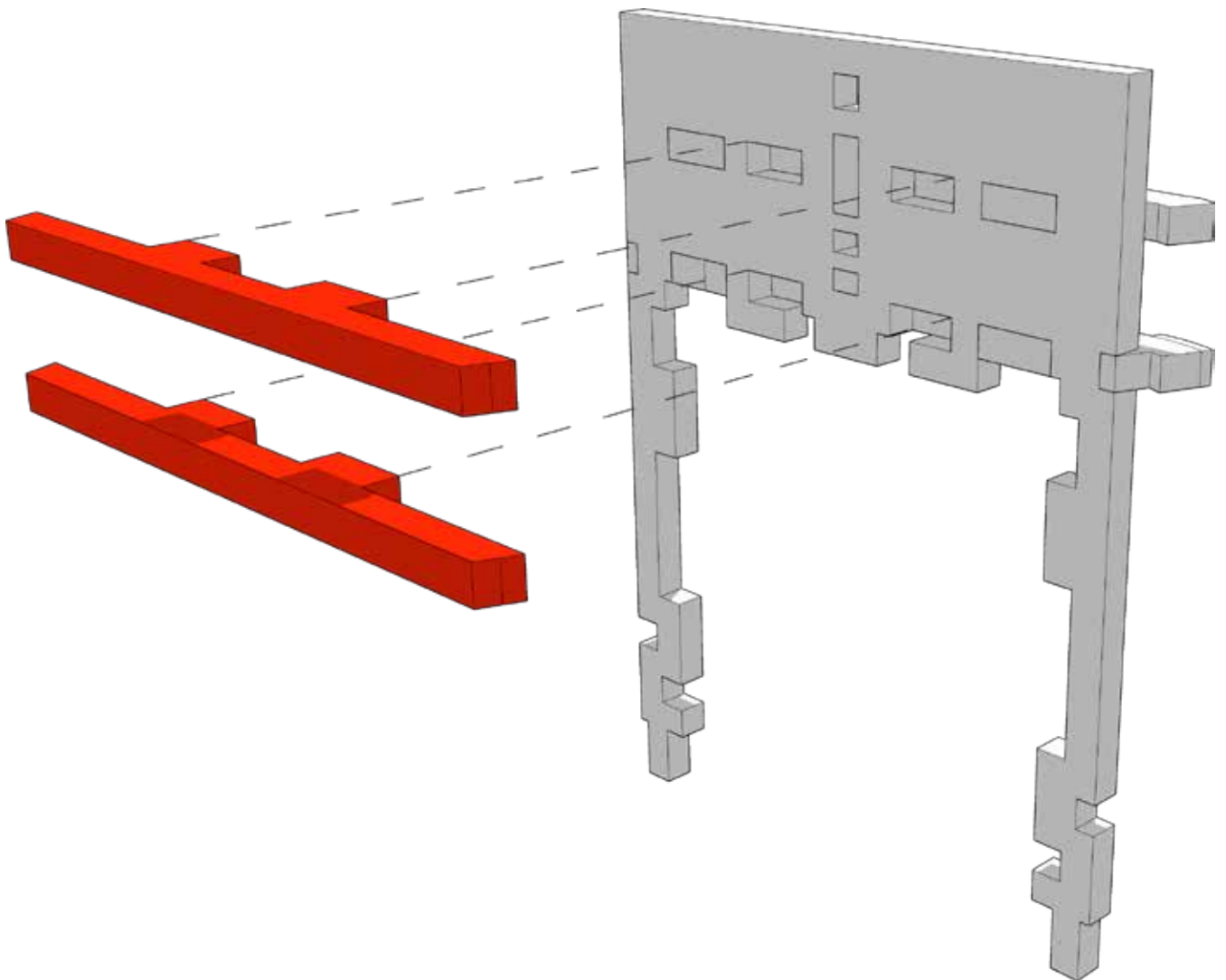



TABLETOP SCENICS

TTSCW-EES-110
Toshi
Hakkei-tō Pagoda

50

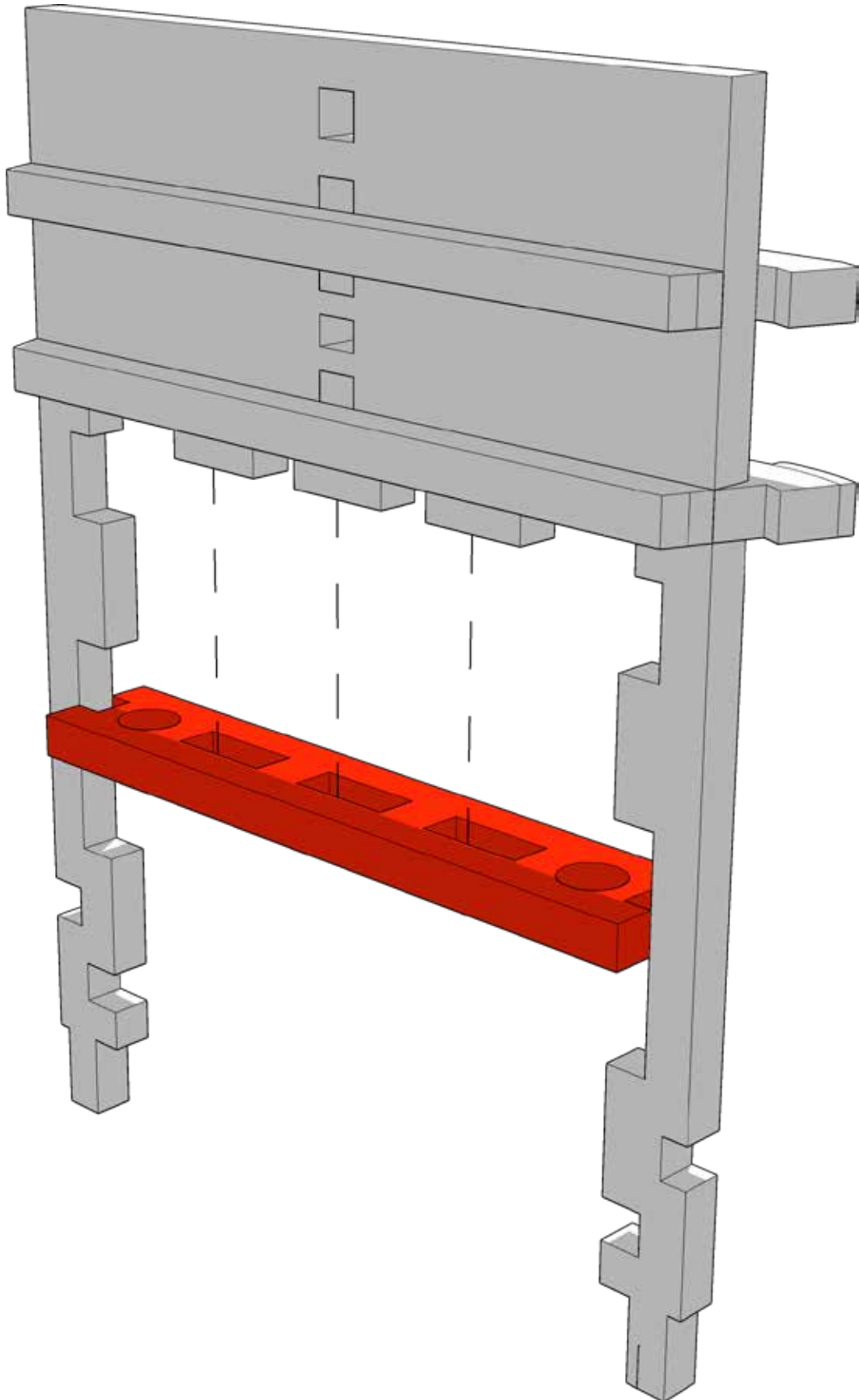



TABLETOP SCENICS

TTSCW-EES-110
Toshi
Hakkei-tō Pagoda

51

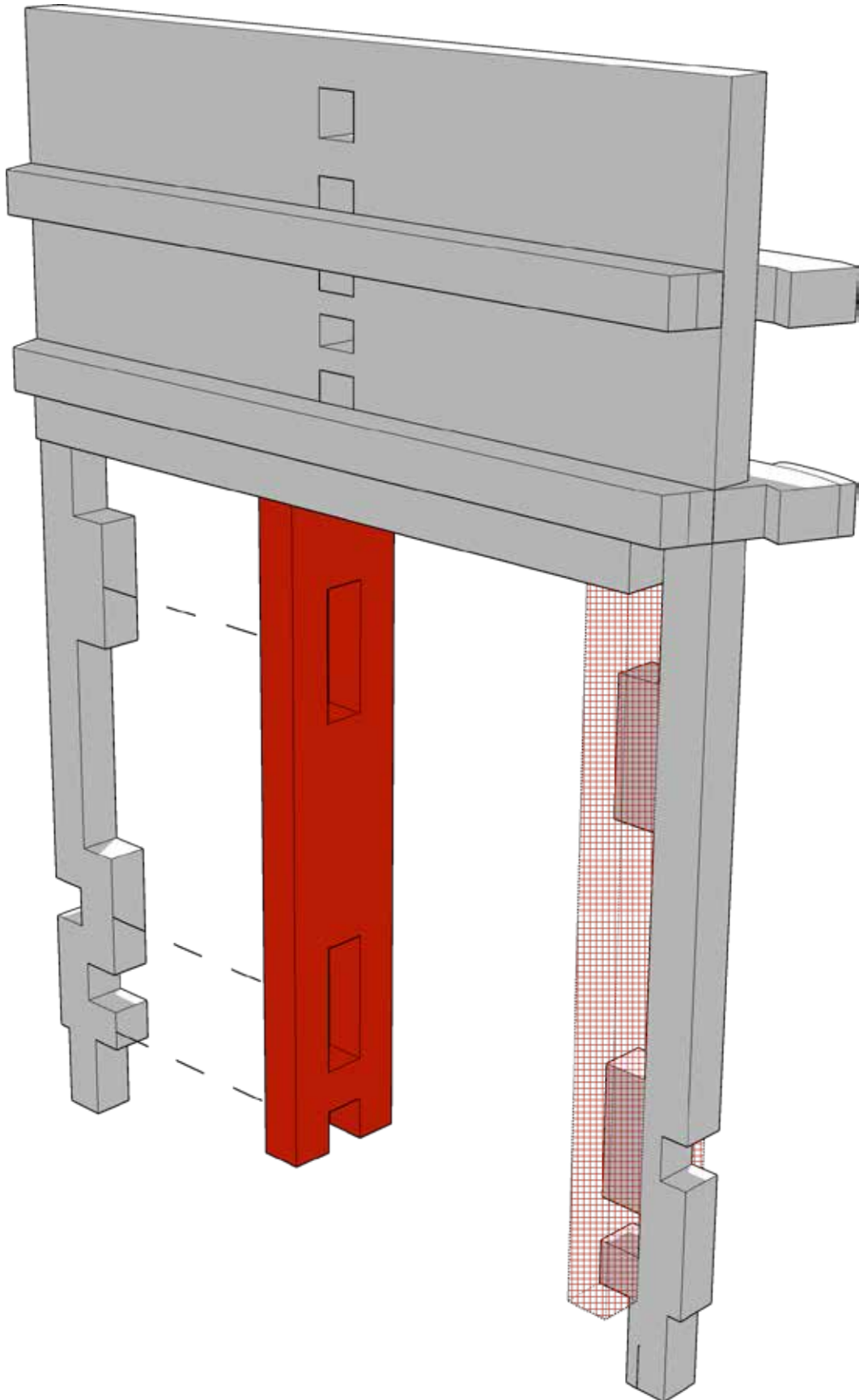

Repeat step on both sides



TABLETOP SCENICS

TTSCW-EES-110
Toshi
Hakkei-tō Pagoda

52

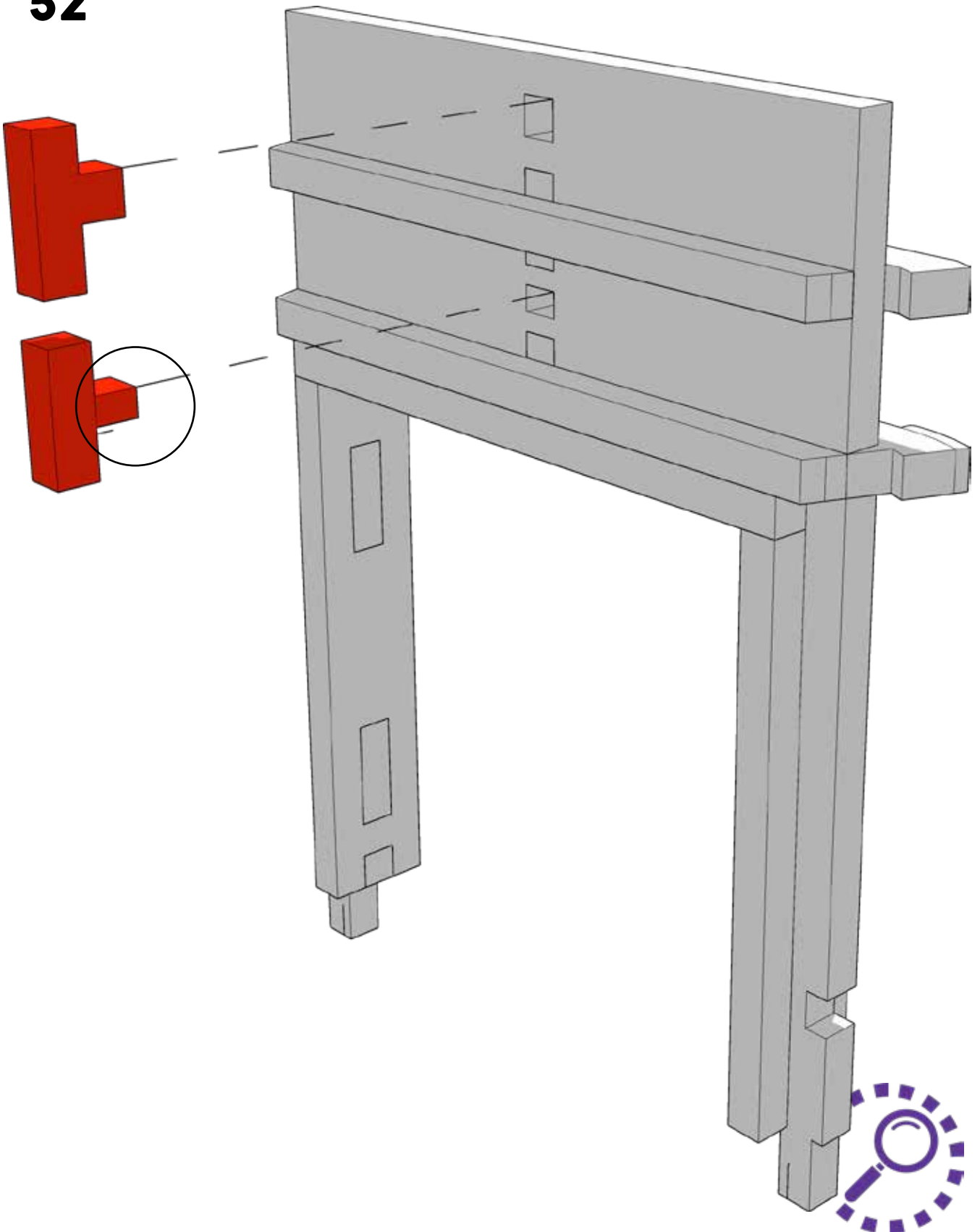

Circled part has a smaller tab than the one above and is labeled "B" on the sprues. The other is labeled "C"



TTCOMBAT



TABLETOP SCENICS

TTSCW-EES-110
Toshi
Hakkei-tō Pagoda

53

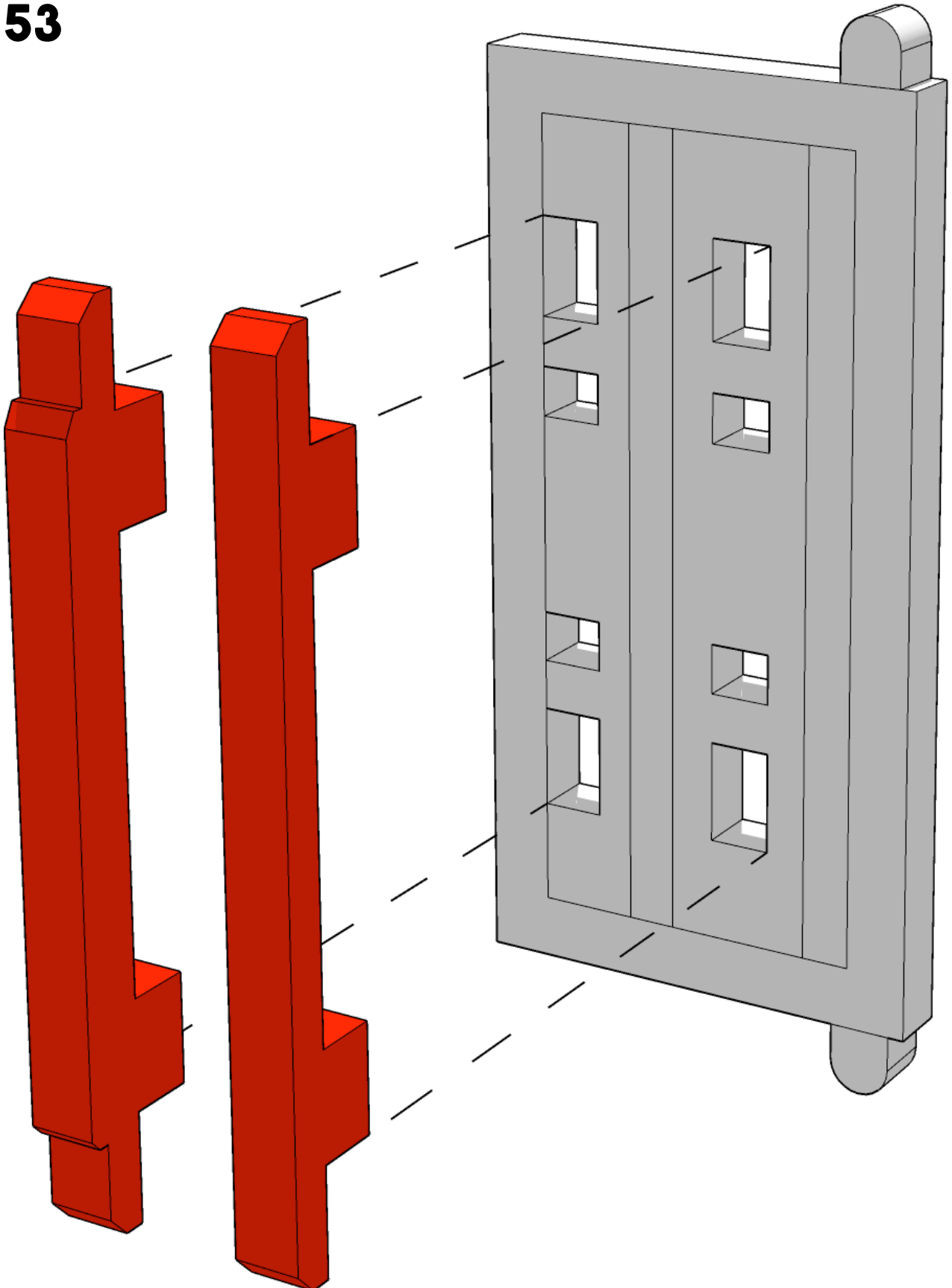



TABLETOP SCENICS

TTSCW-EES-110
Toshi
Hakkei-tō Pagoda

54

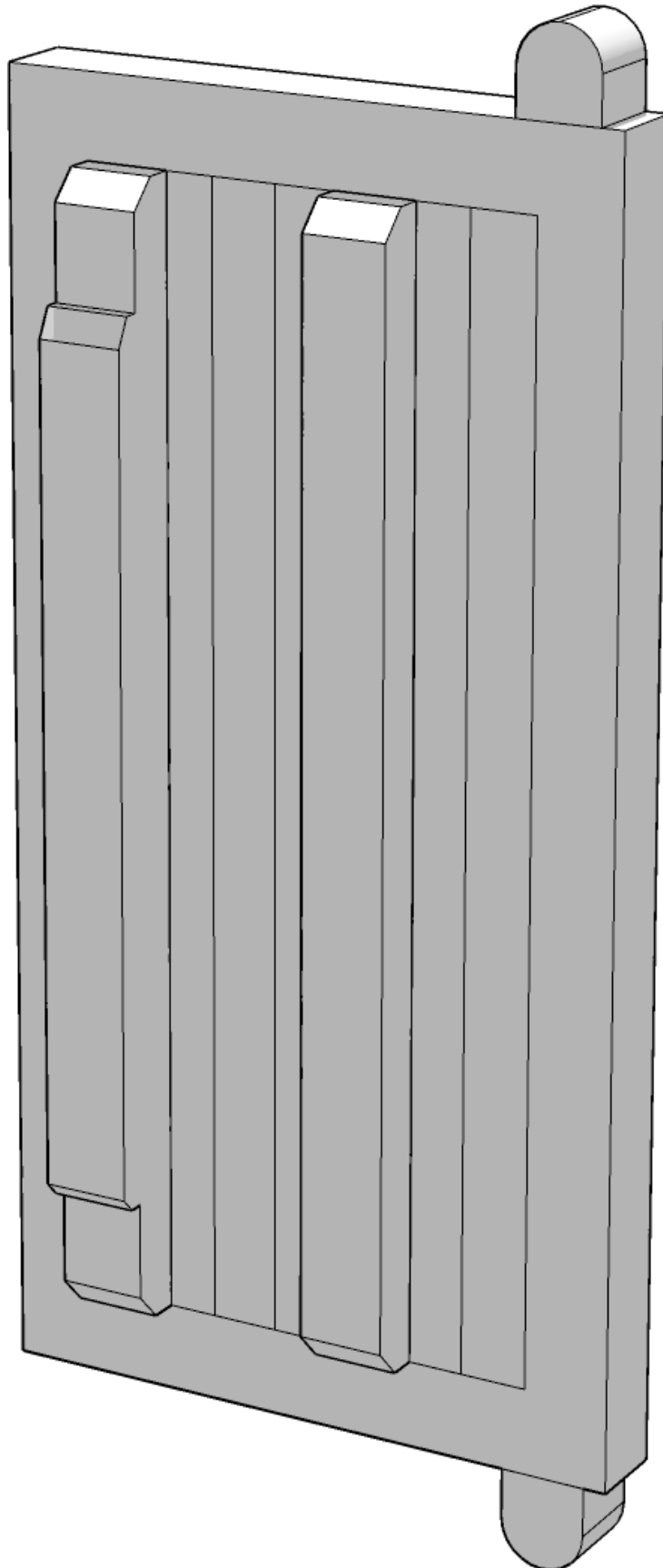



TABLETOP SCENICS

TTSCW-EES-110
Toshi
Hakkei-tō Pagoda

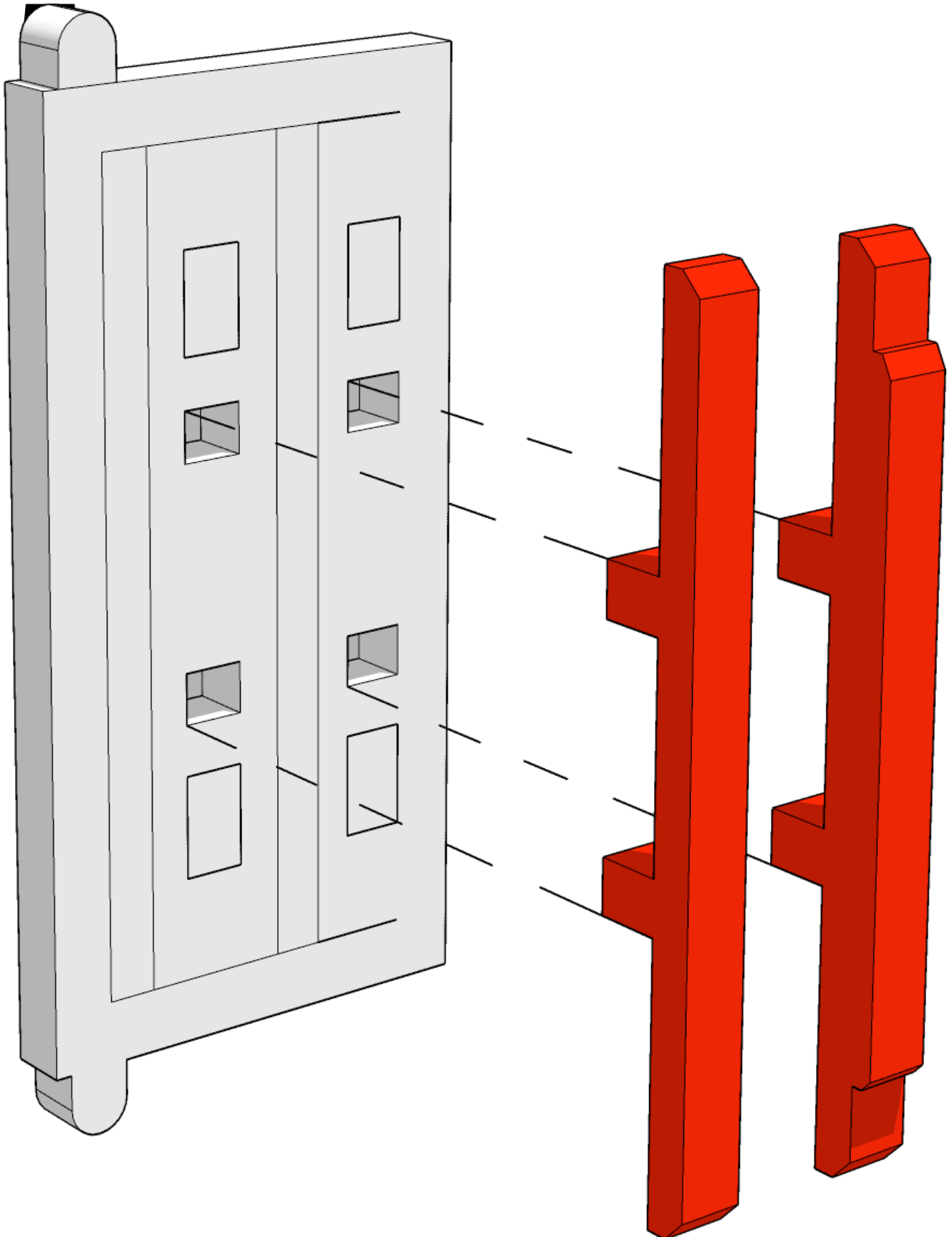



TABLETOP SCENICS

TTSCW-EES-110
Toshi
Hakkei-tō Pagoda

56

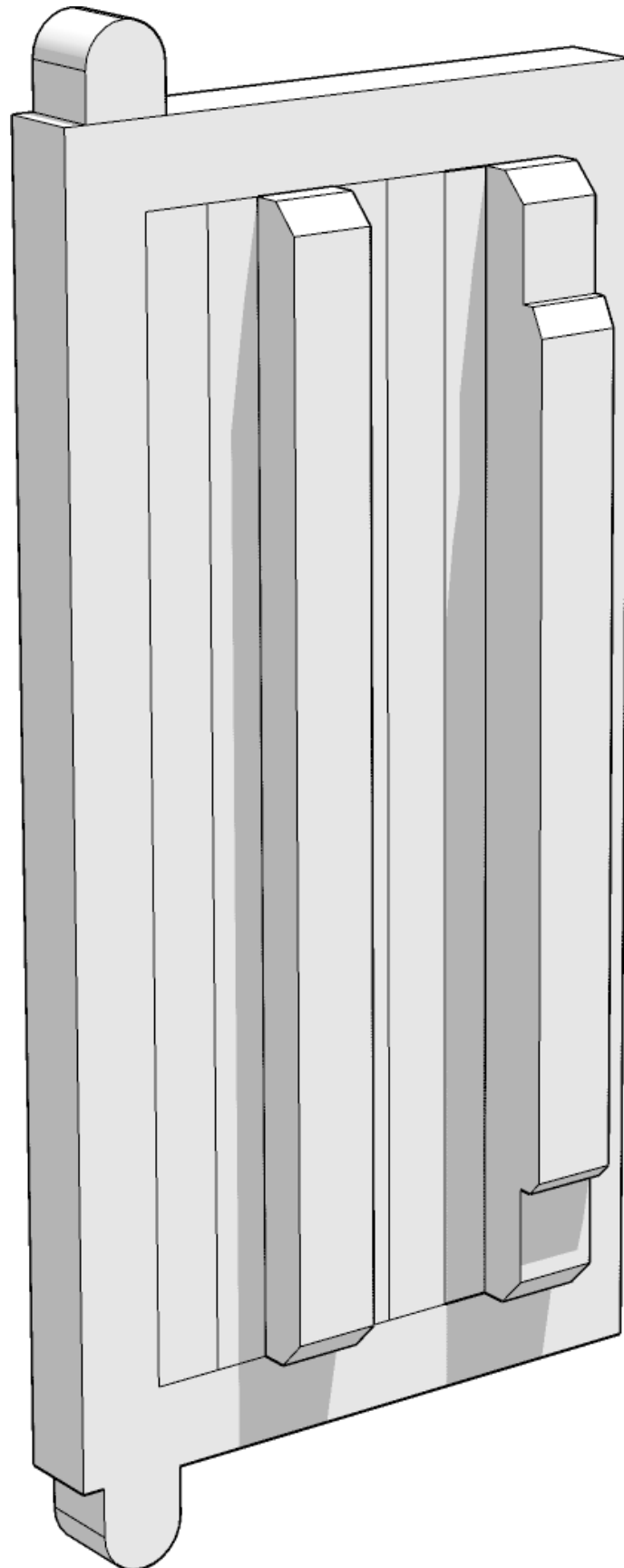

x4



TABLETOP SCENICS

TTSCW-EES-110
Toshi
Hakkei-tō Pagoda

57

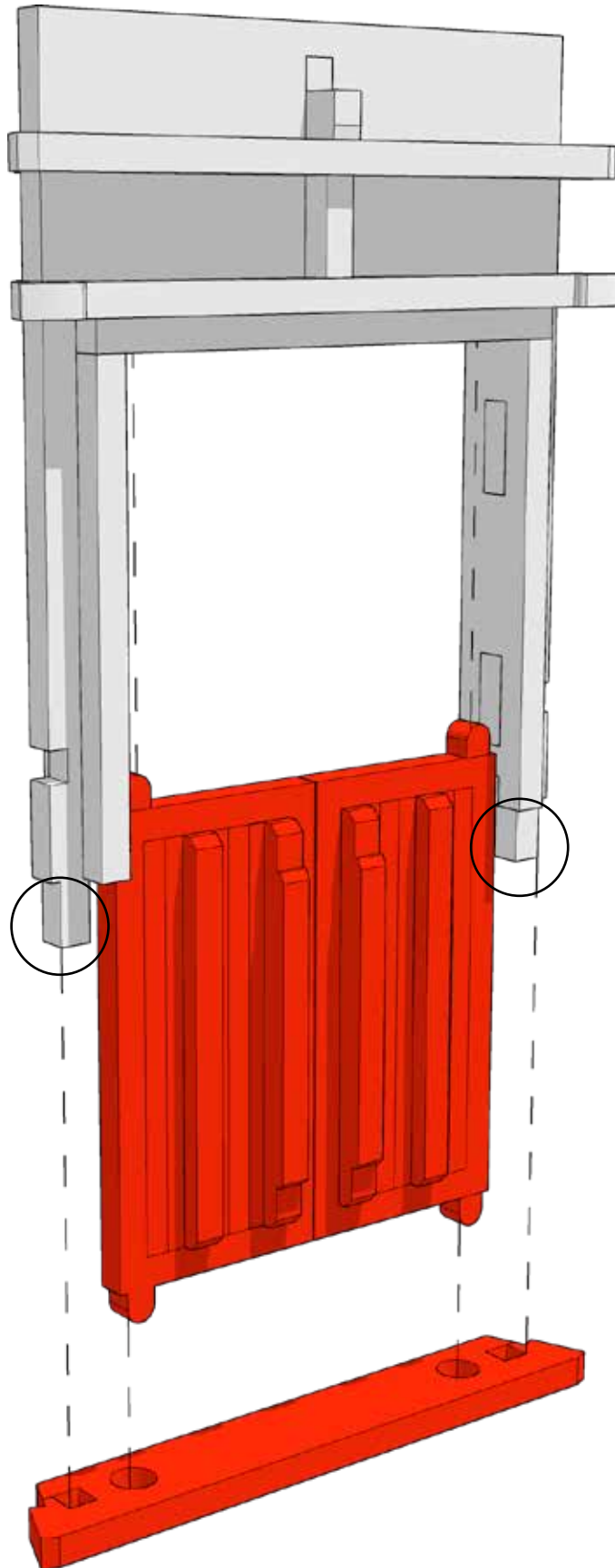

Do not glue the doors, only glue the floor to the square tabs circled



 **TTCOMBAT**



58

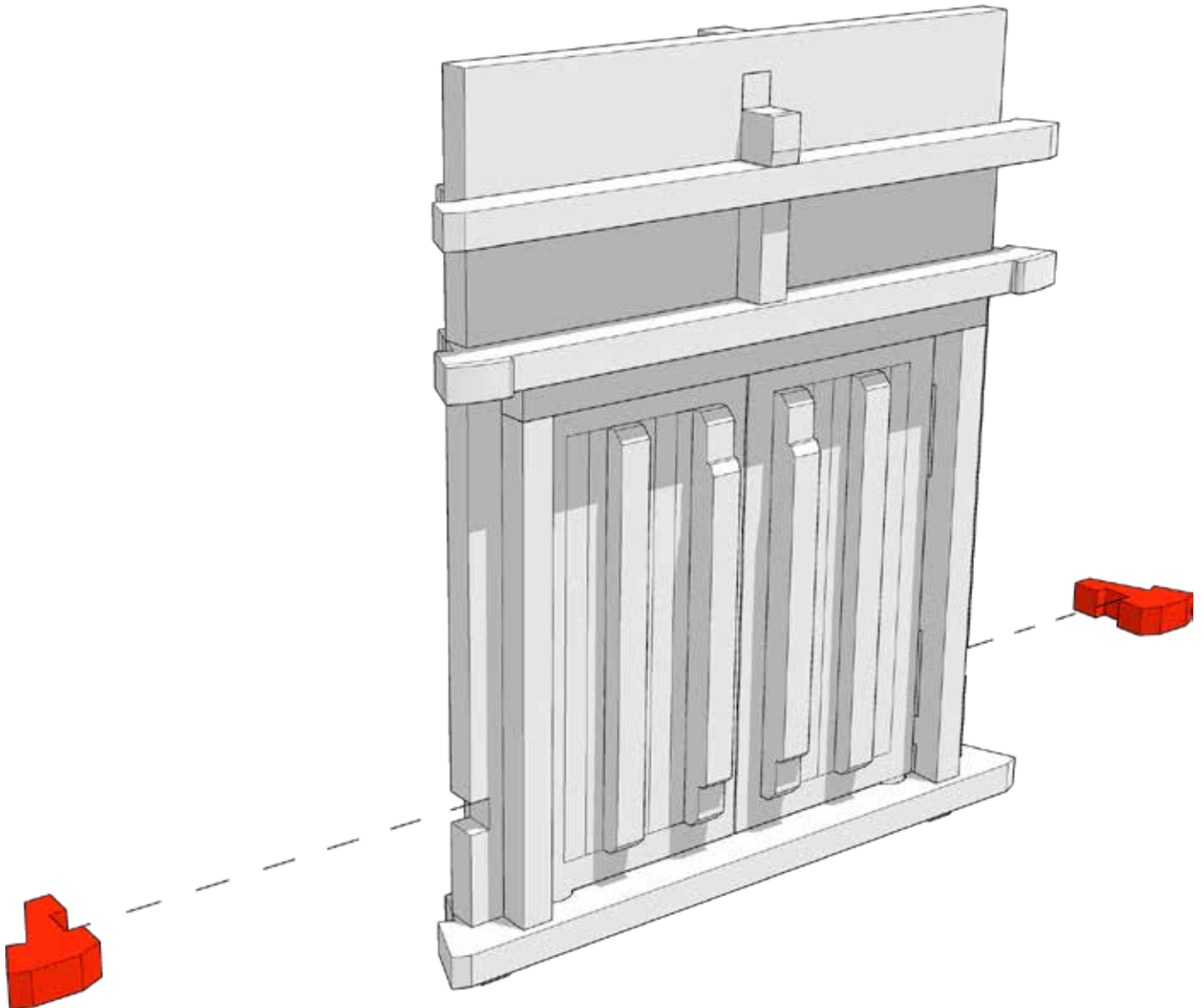

There are similar parts. The green highlighted one is required for the step shown on this page. Found on Sheet 7



TABLETOP SCENICS

TTSCW-EES-110
Toshi
Hakkei-tō Pagoda

59

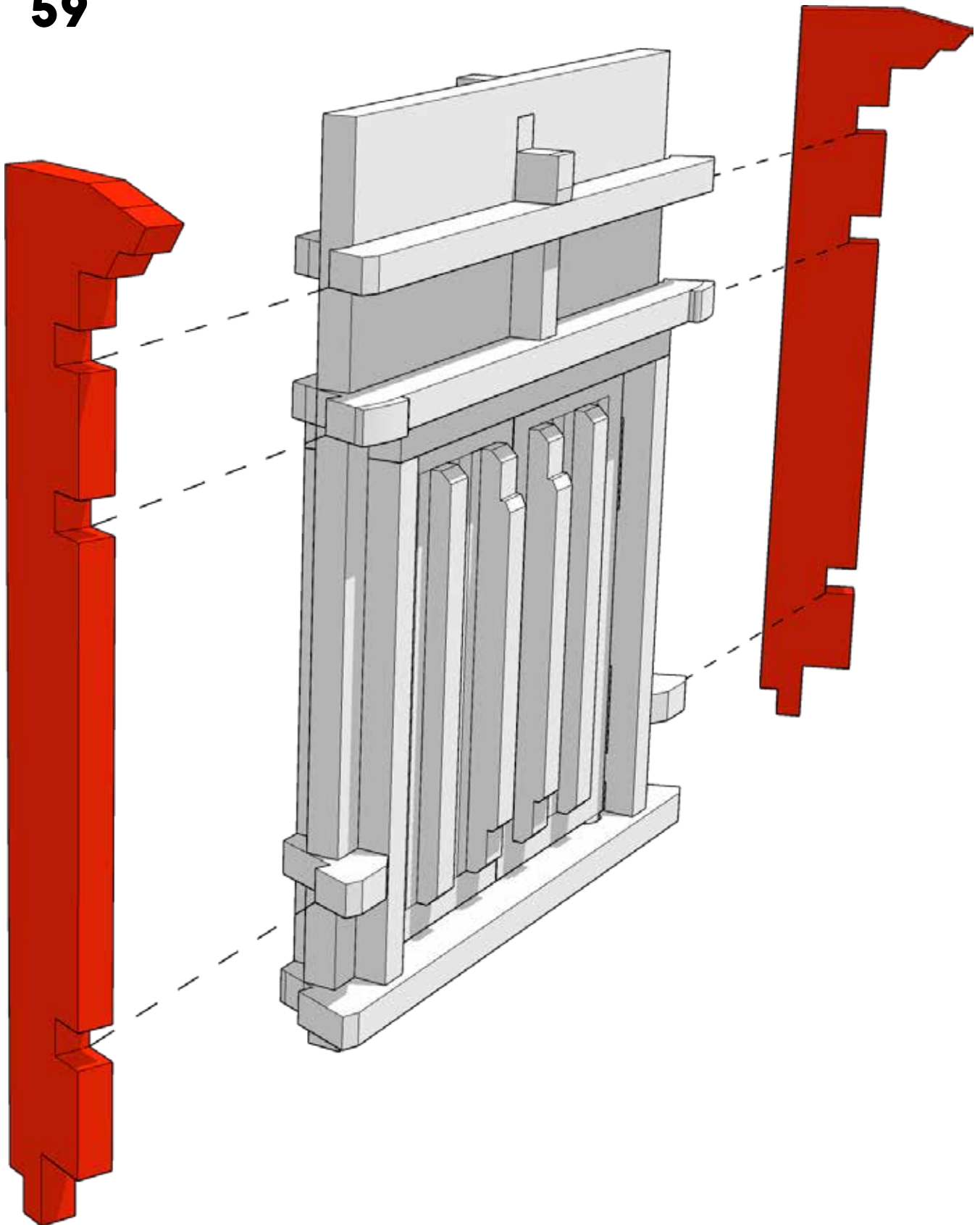



TABLETOP SCENICS

TTSCW-EES-110
Toshi
Hakkei-tō Pagoda

60

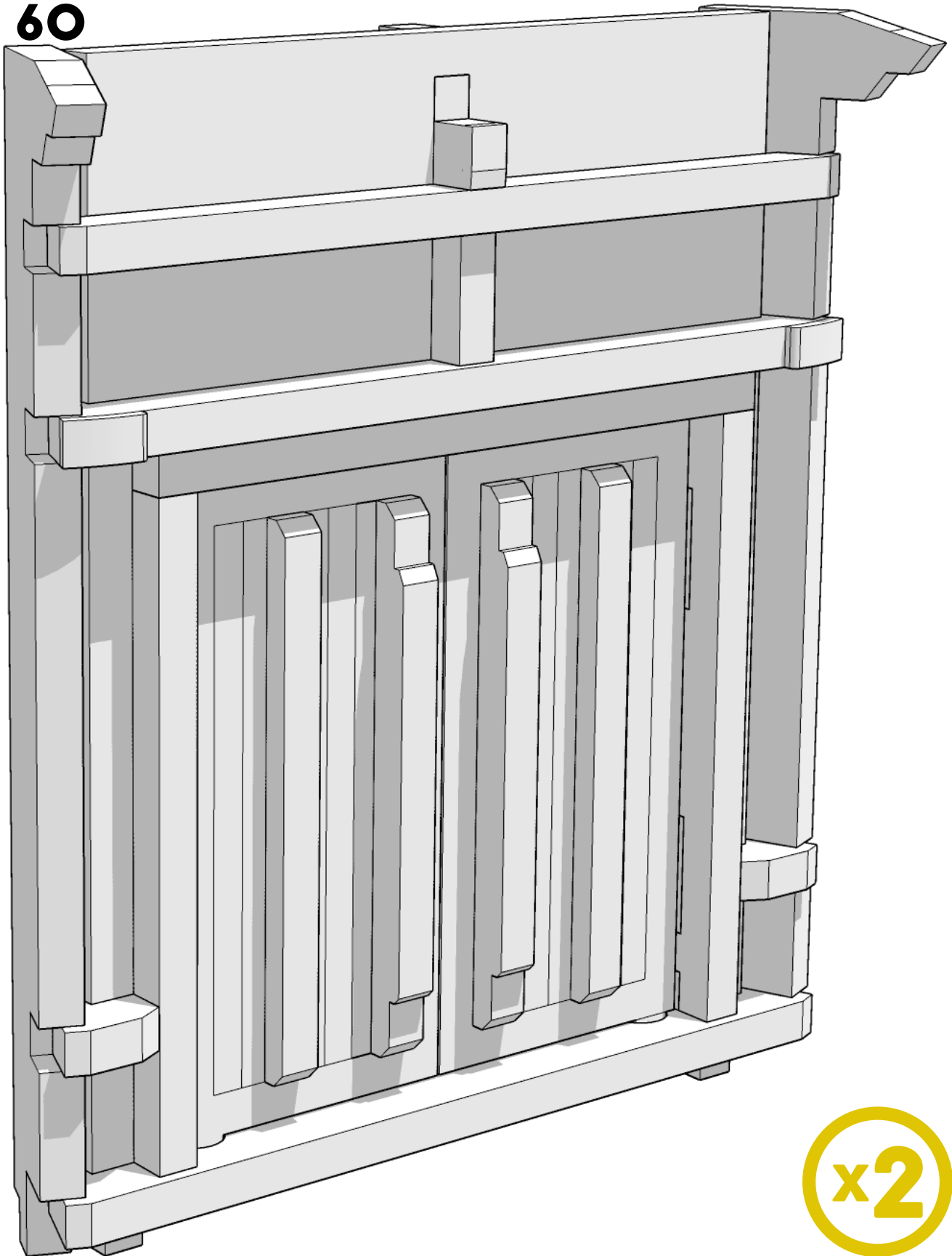

x2



TABLETOP SCENICS

TTSCW-EES-110
Toshi
Hakkei-tō Pagoda

61

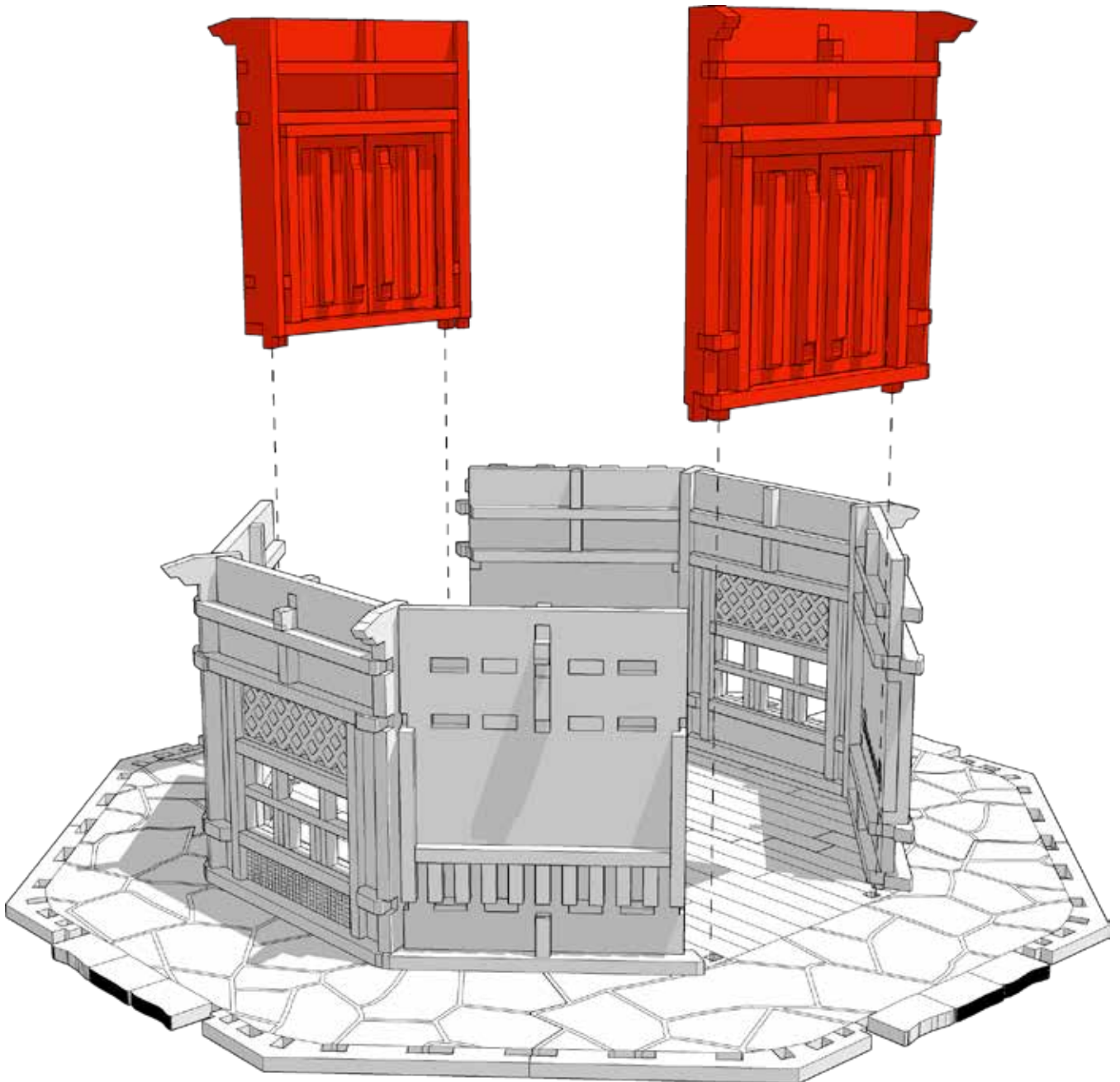



TABLETOP SCENICS

TTSCW-EES-110
Toshi
Hakkei-tō Pagoda

62

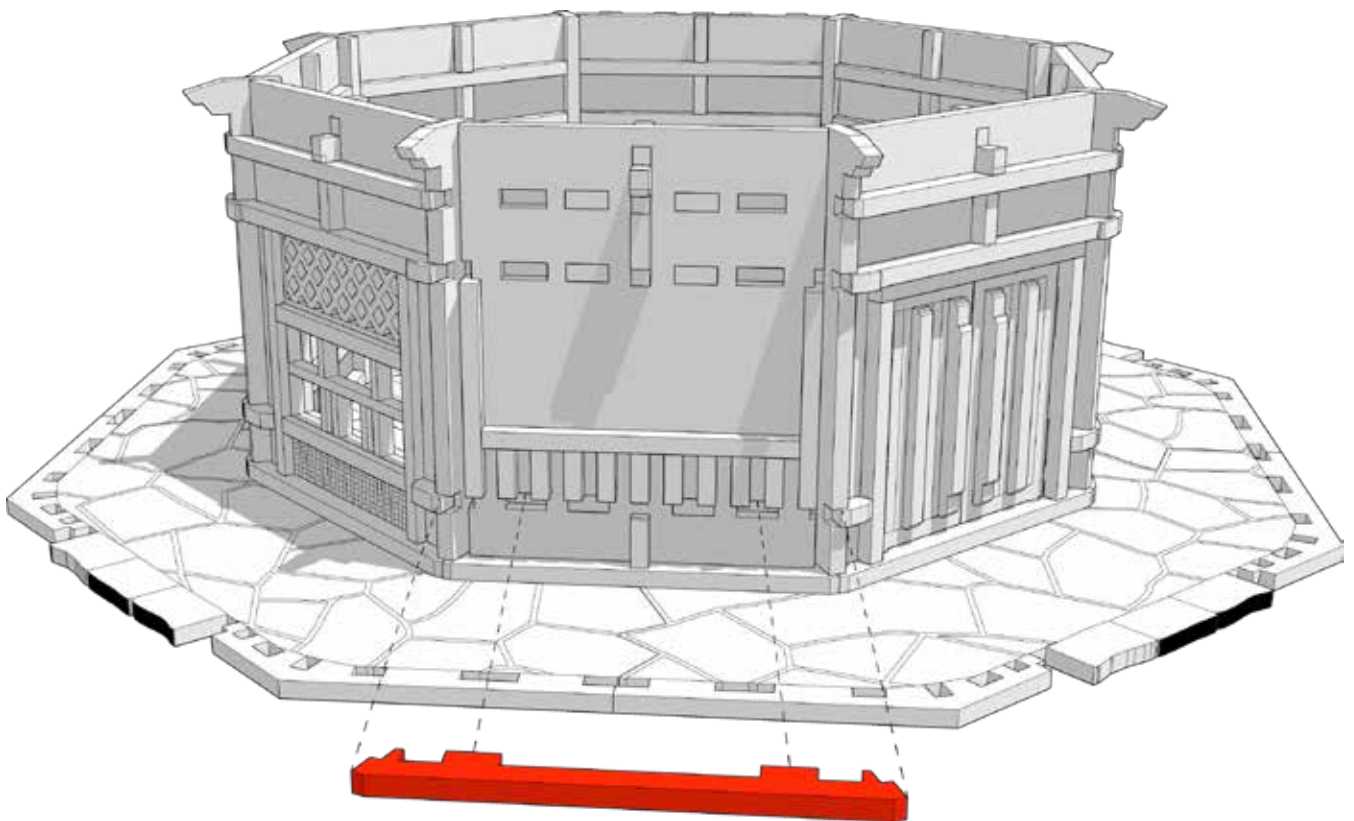

Repeat this step for the other same 3 walls. It should align with the edges of the other walls to lock each section together



 TTCOMBAT



TABLETOP SCENICS

TTSCW-EES-110
Toshi
Hakkei-tō Pagoda

63

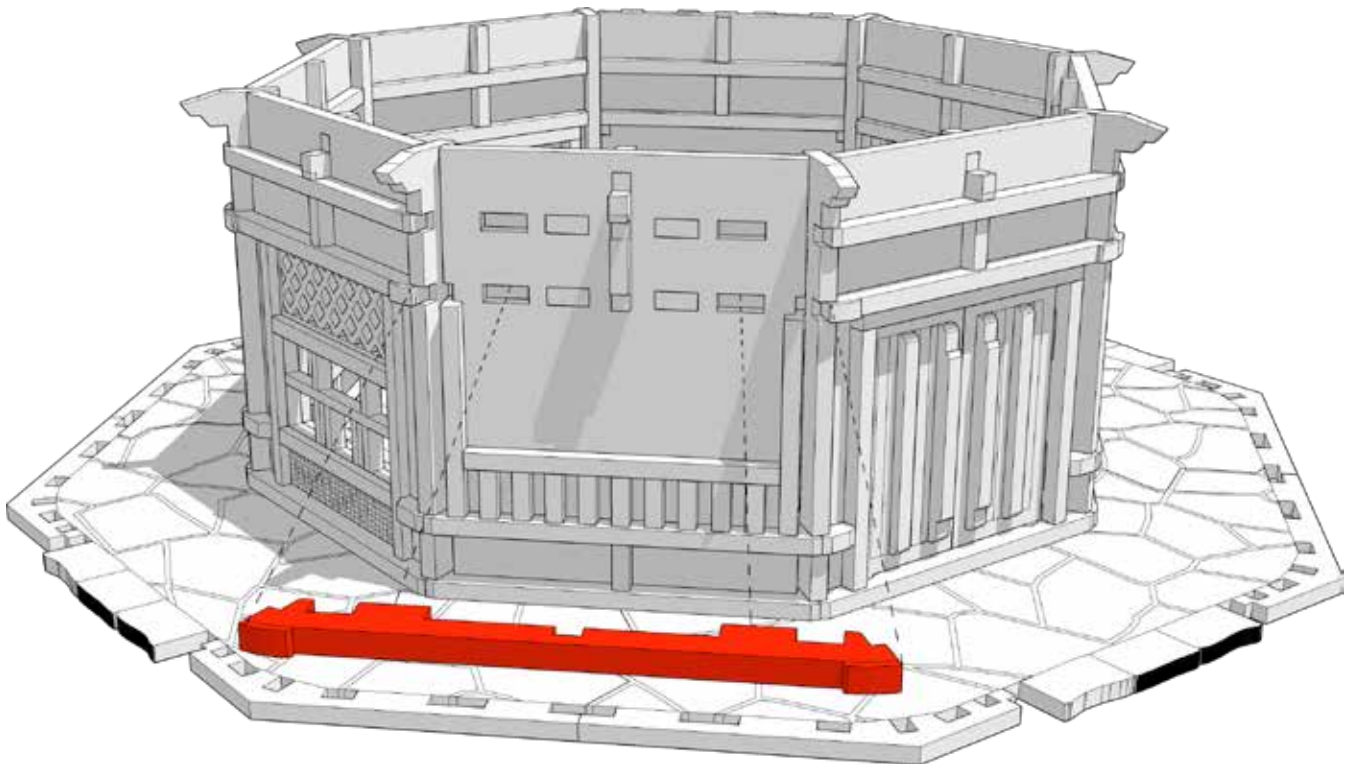

Repeat this step for the other same 3 walls. It should align with the edges of the other walls to lock each section together



 TTCOMBAT



TABLETOP SCENICS

TTSCW-EES-110
Toshi
Hakkei-tō Pagoda

64

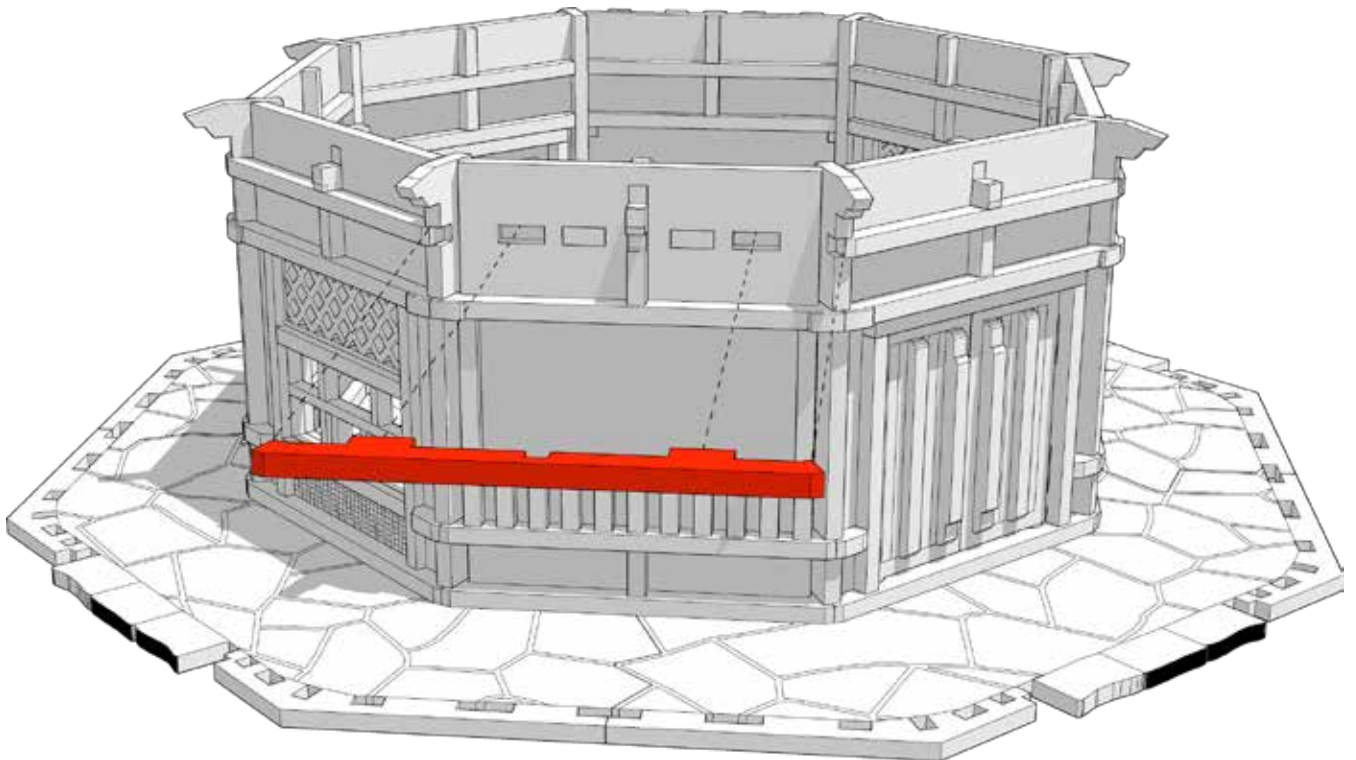

Repeat this step for the other same 3 walls. It should align with the edges of the other walls to lock each section together



 **TTCOMBAT**



TABLETOP SCENICS

TTSCW-EES-110
Toshi
Hakkei-tō Pagoda

65

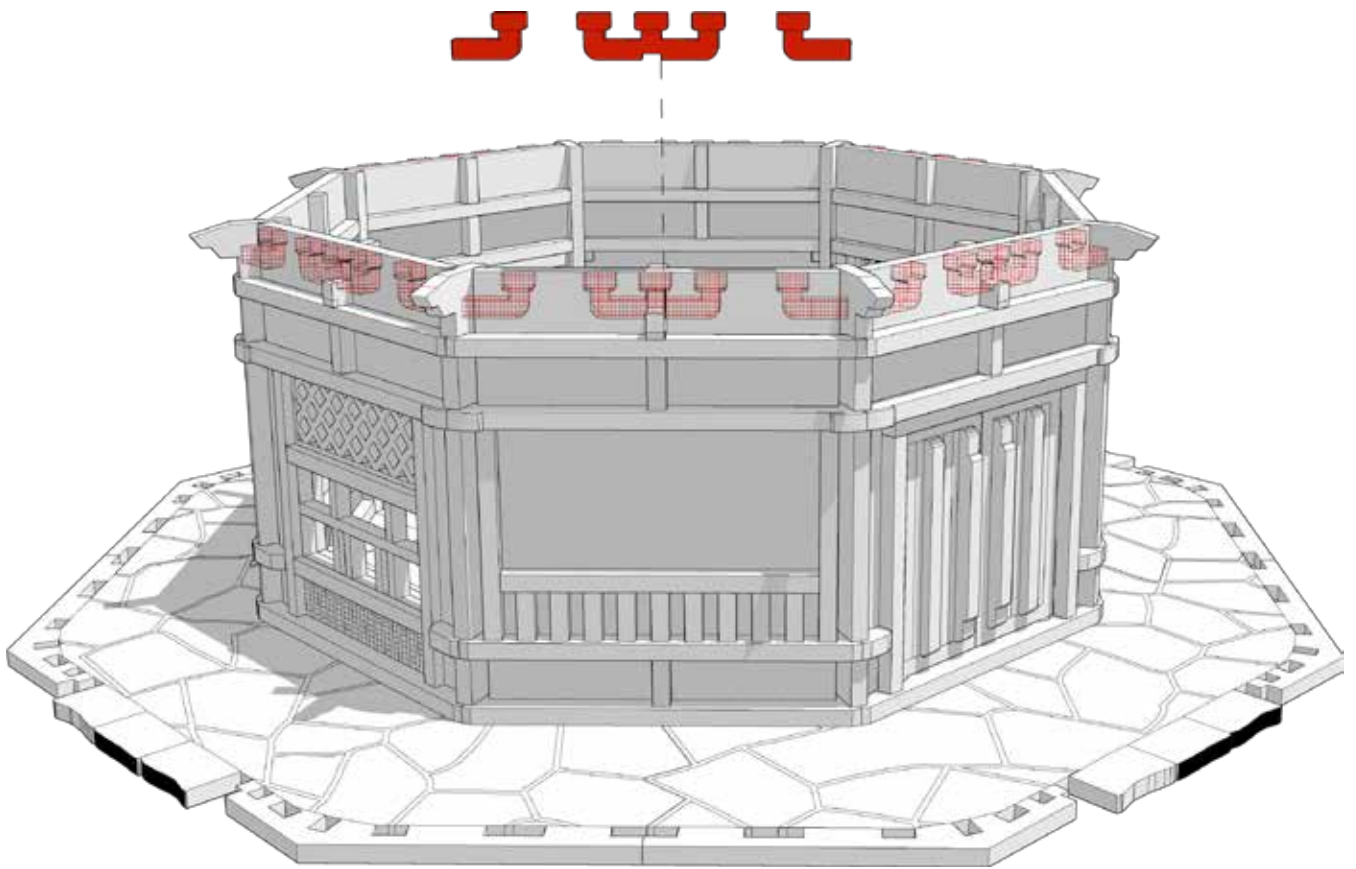

Repeat step all the way around



 TTCOMBAT



TABLETOP SCENICS

TTSCW-EES-110
Toshi
Hakkei-tō Pagoda

66

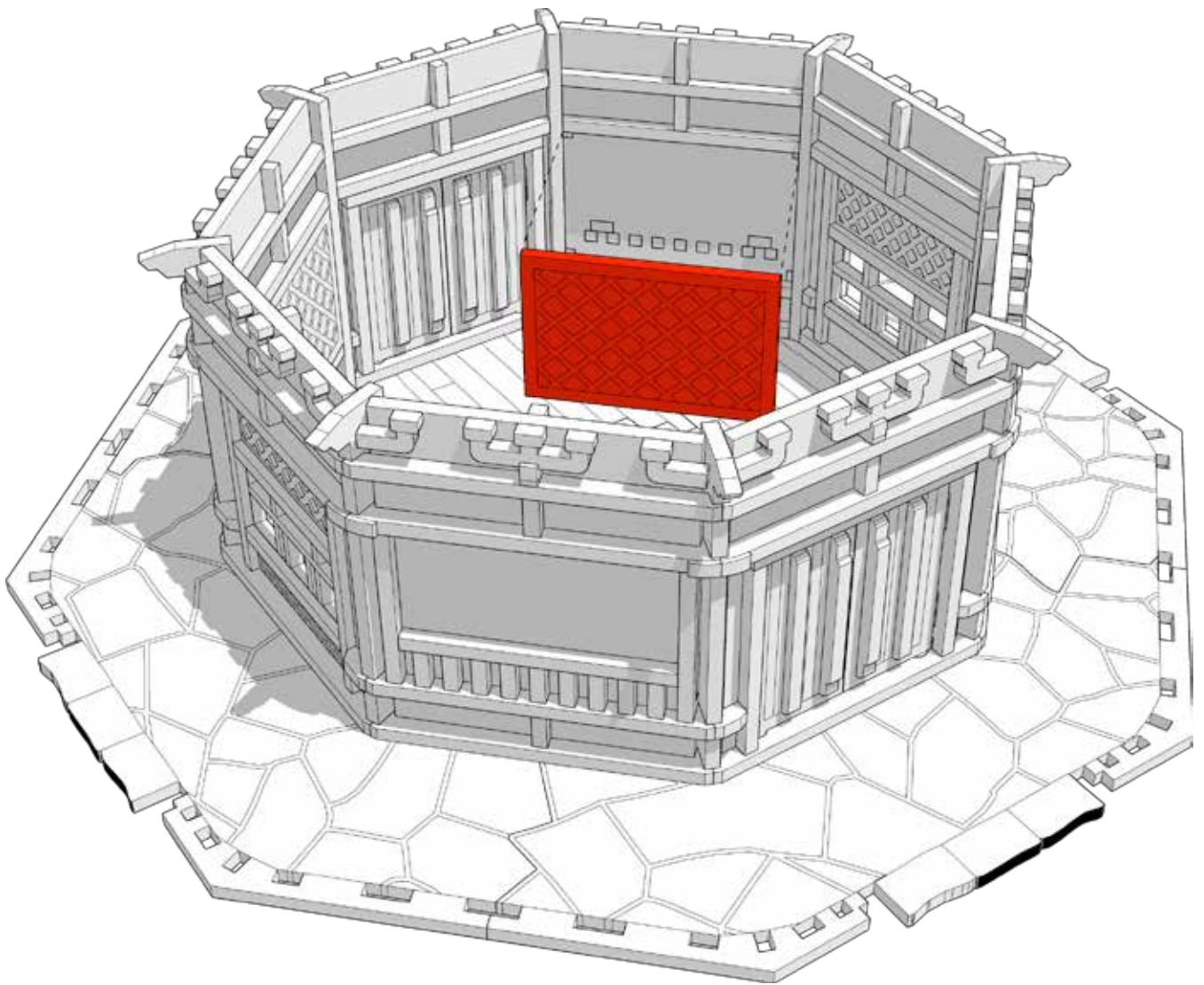

Repeat step with the other 3 walls



 TTCOMBAT



TABLETOP SCENICS

TTSCW-EES-110
Toshi
Hakkei-tō Pagoda

67

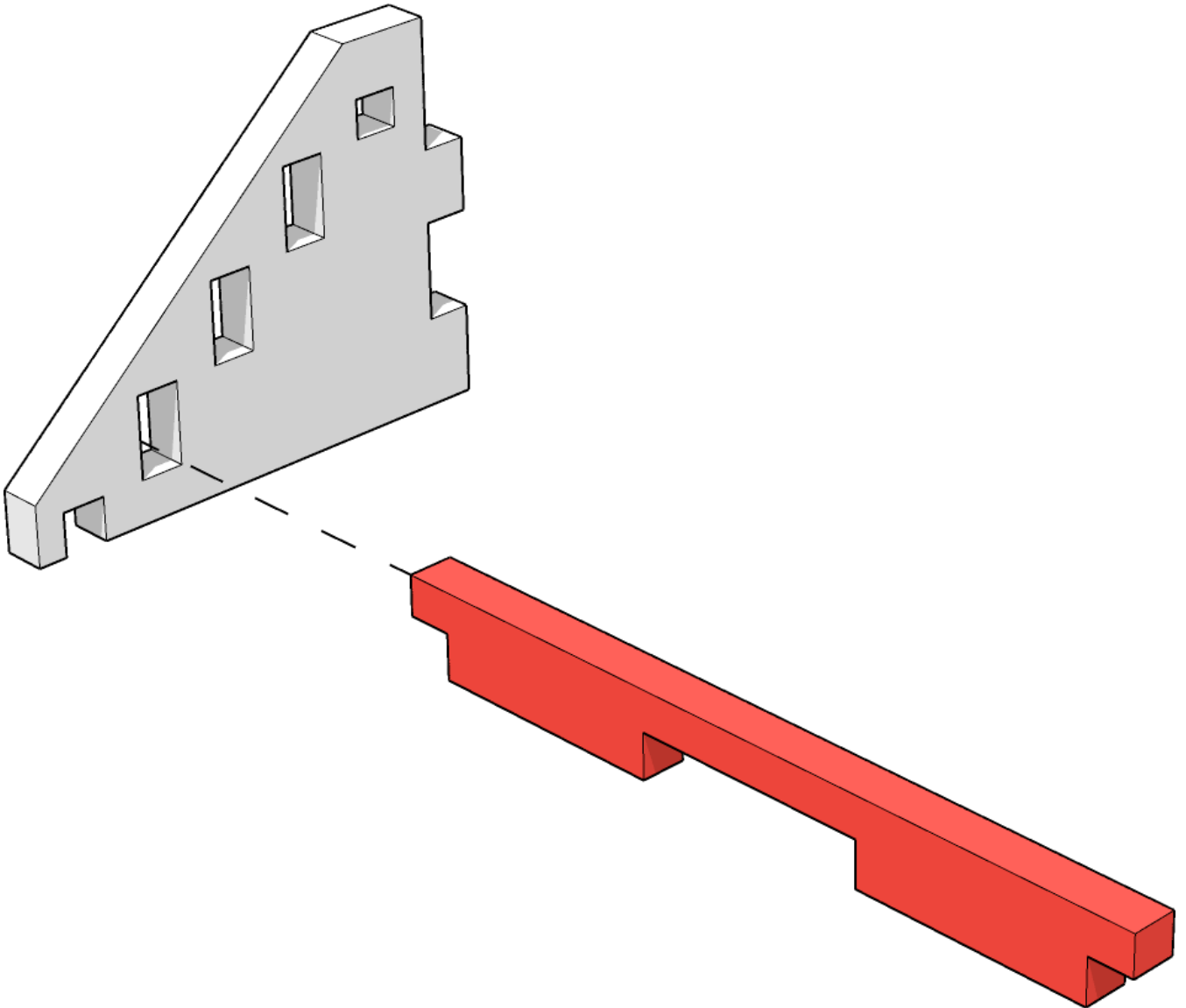



TABLETOP SCENICS

TTSCW-EES-110
Toshi
Hakkei-tō Pagoda

68

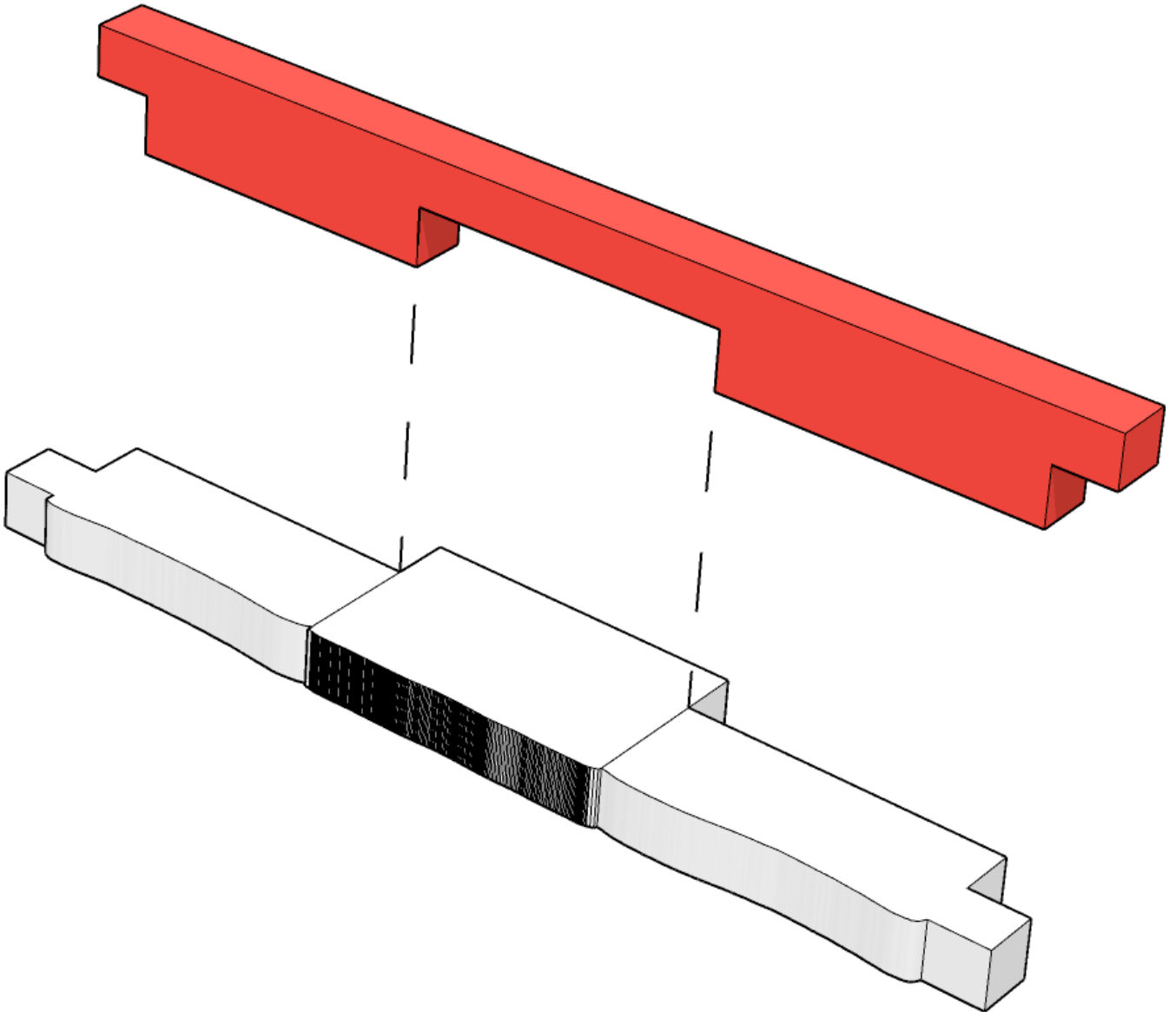



TABLETOP SCENICS

TTSCW-EES-110
Toshi
Hakkei-tō Pagoda

69

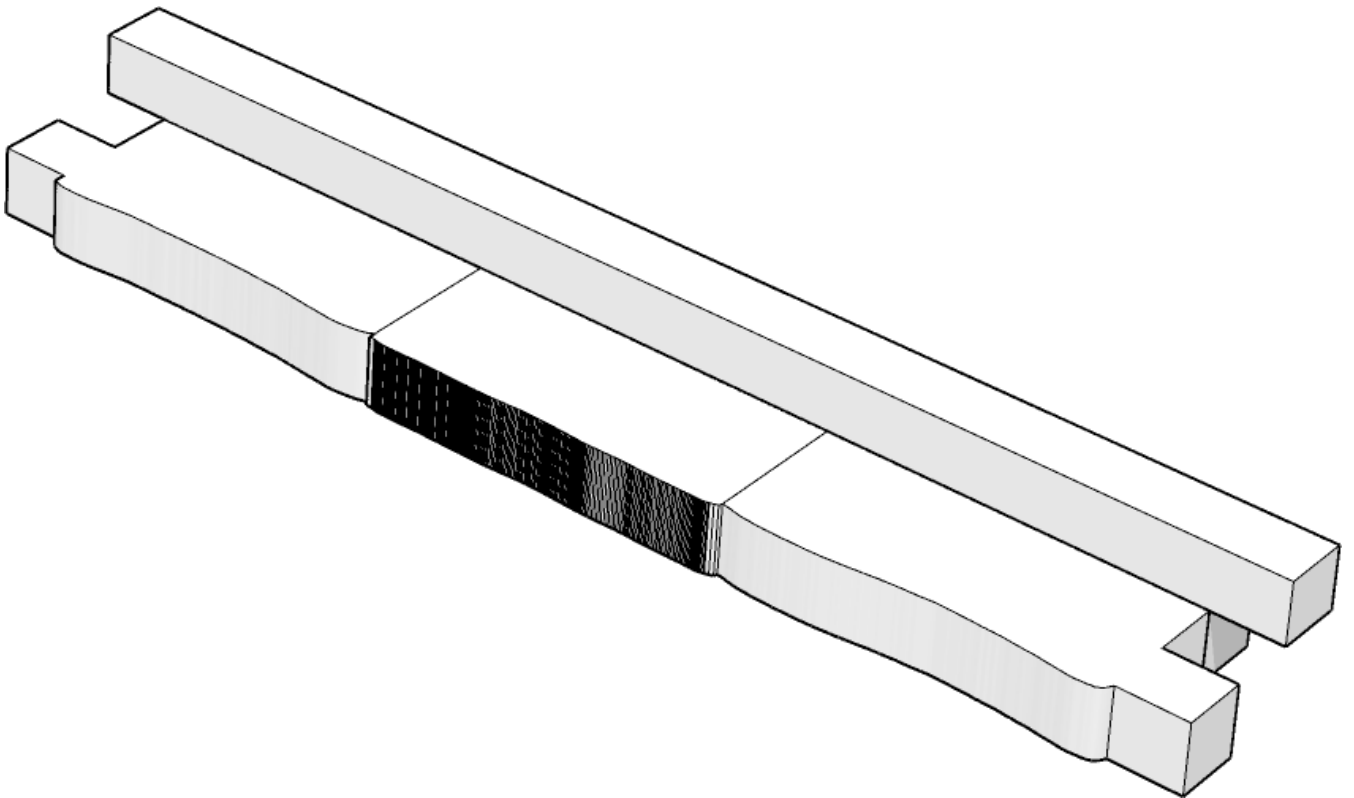

x3

 **TTCOMBAT**



TABLETOP SCENICS

70

TTSCW-EES-110
Toshi
Hakkei-tō Pagoda

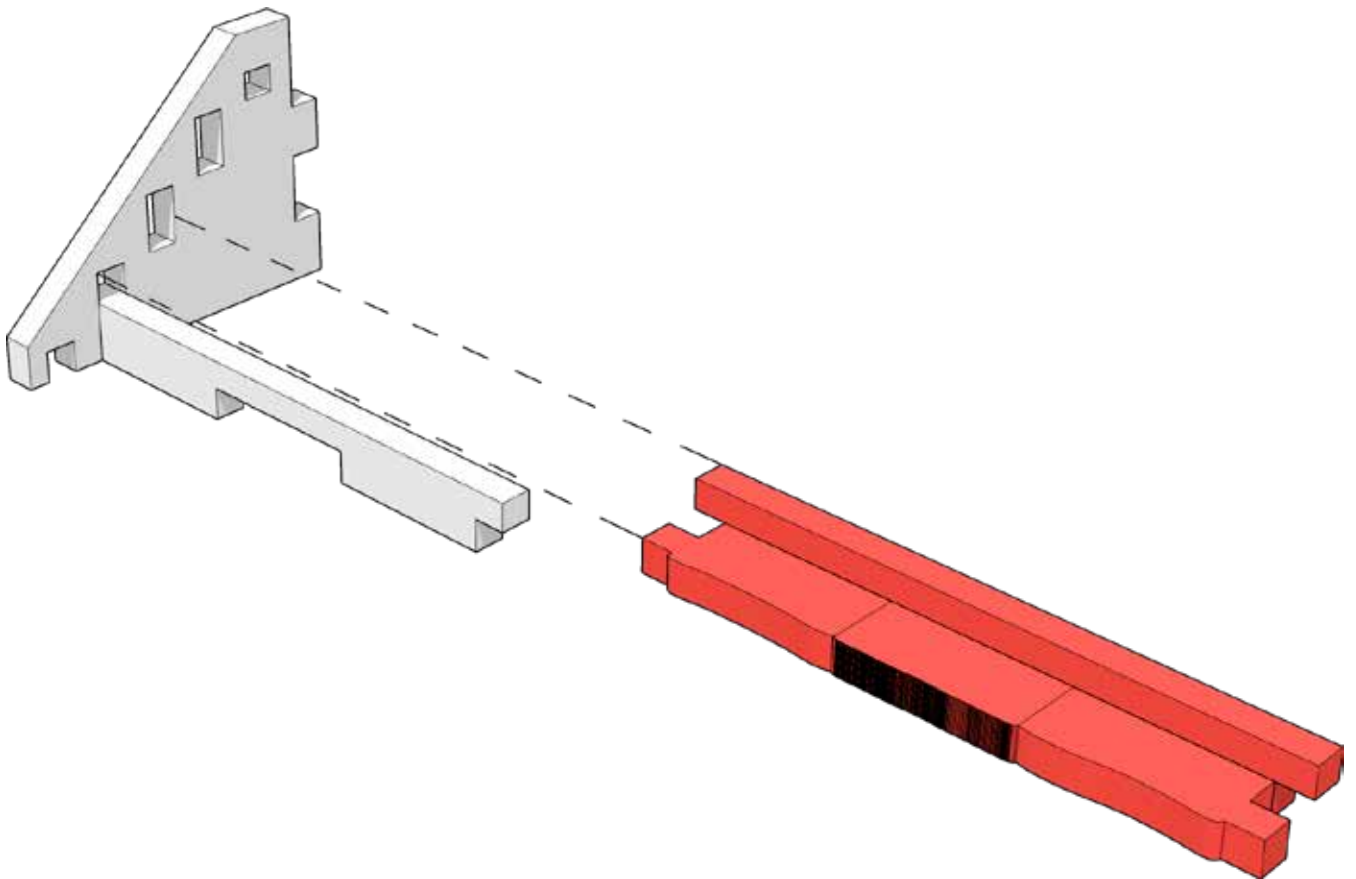



TABLETOP SCENICS

TTSCW-EES-110
Toshi
Hakkei-tō Pagoda

71

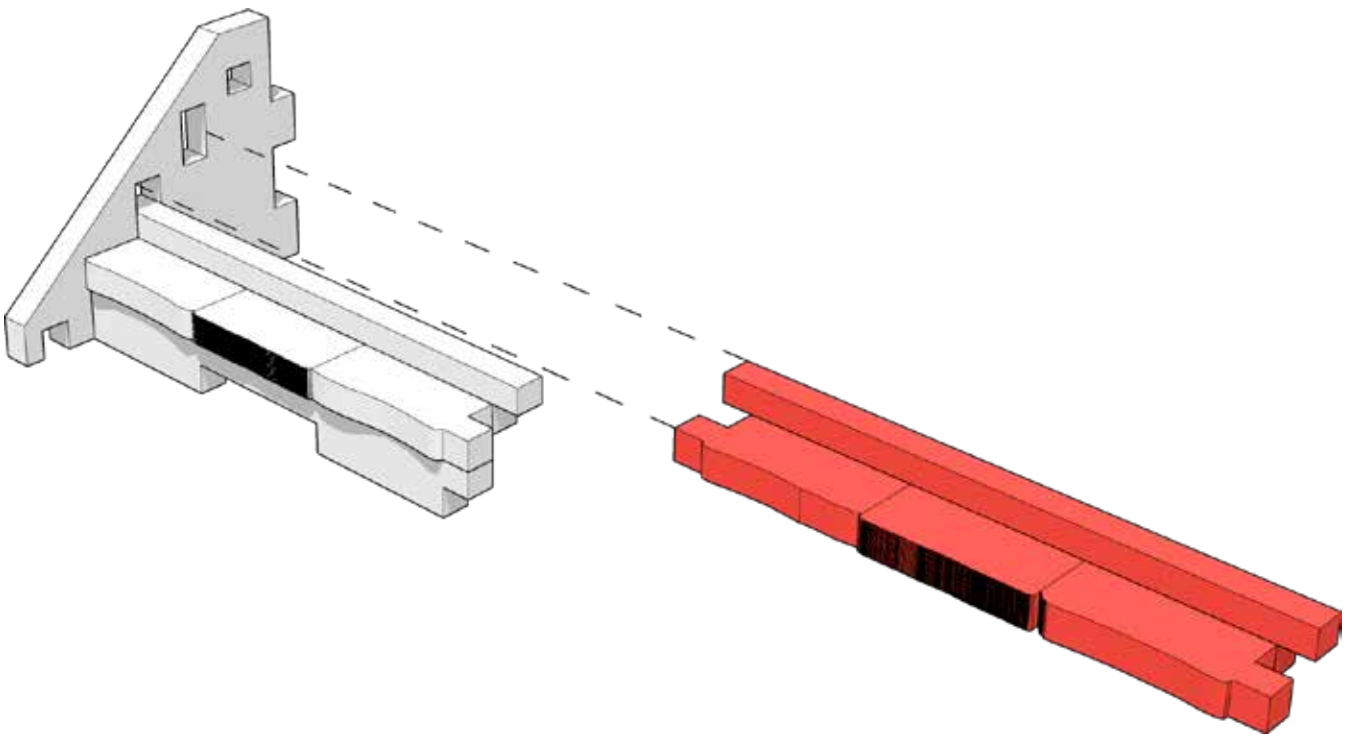



TABLETOP SCENICS

TTSCW-EES-110
Toshi
Hakkei-tō Pagoda

72

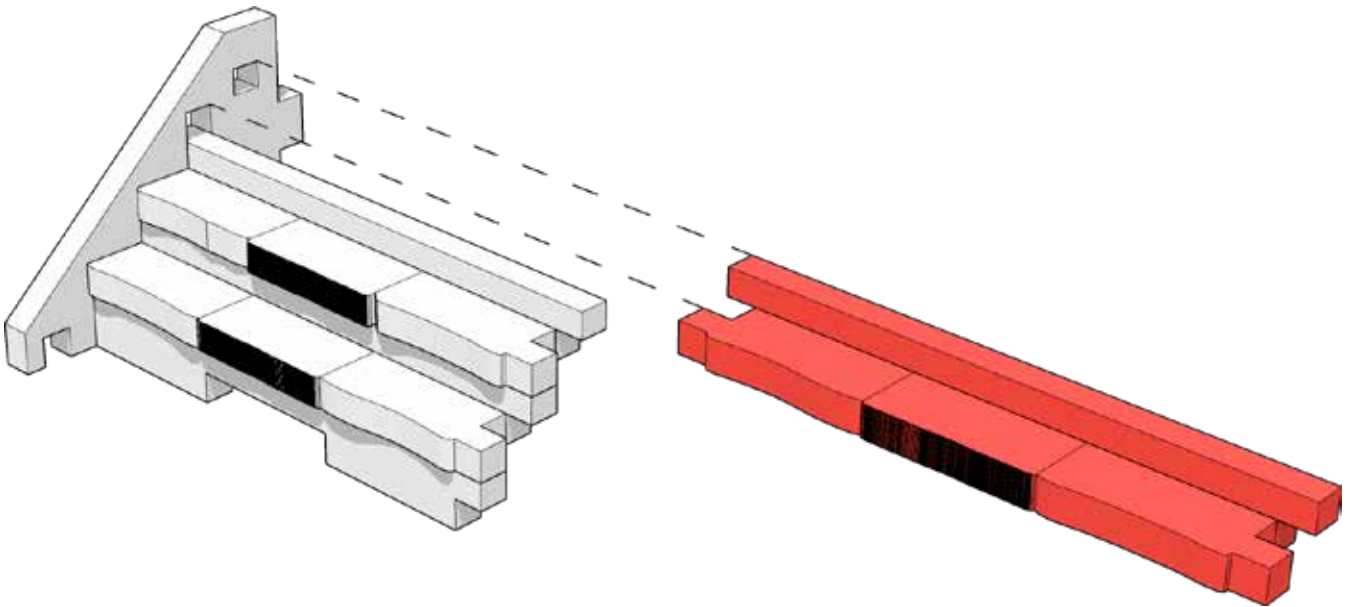



TABLETOP SCENICS

TTSCW-EES-110
Toshi
Hakkei-tō Pagoda

73

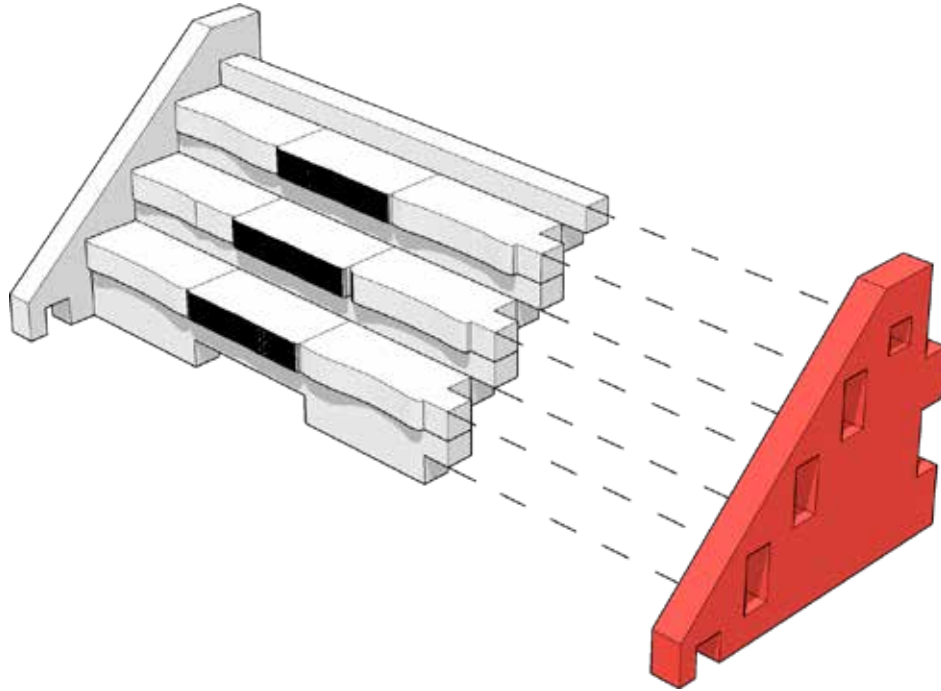



TABLETOP SCENICS

TTSCW-EES-110
Toshi
Hakkei-tō Pagoda

74

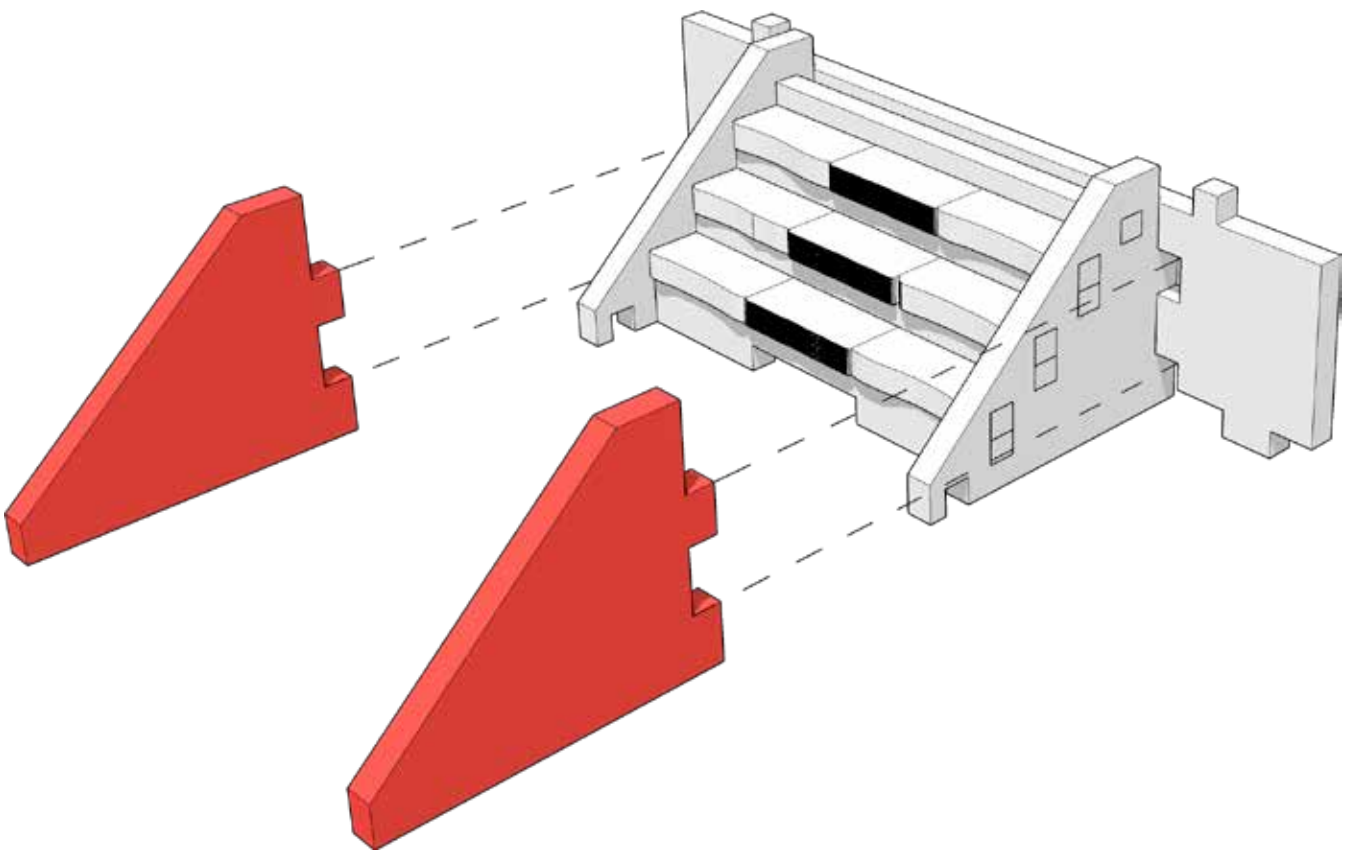



TABLETOP SCENICS

TTSCW-EES-110
Toshi
Hakkei-tō Pagoda

75

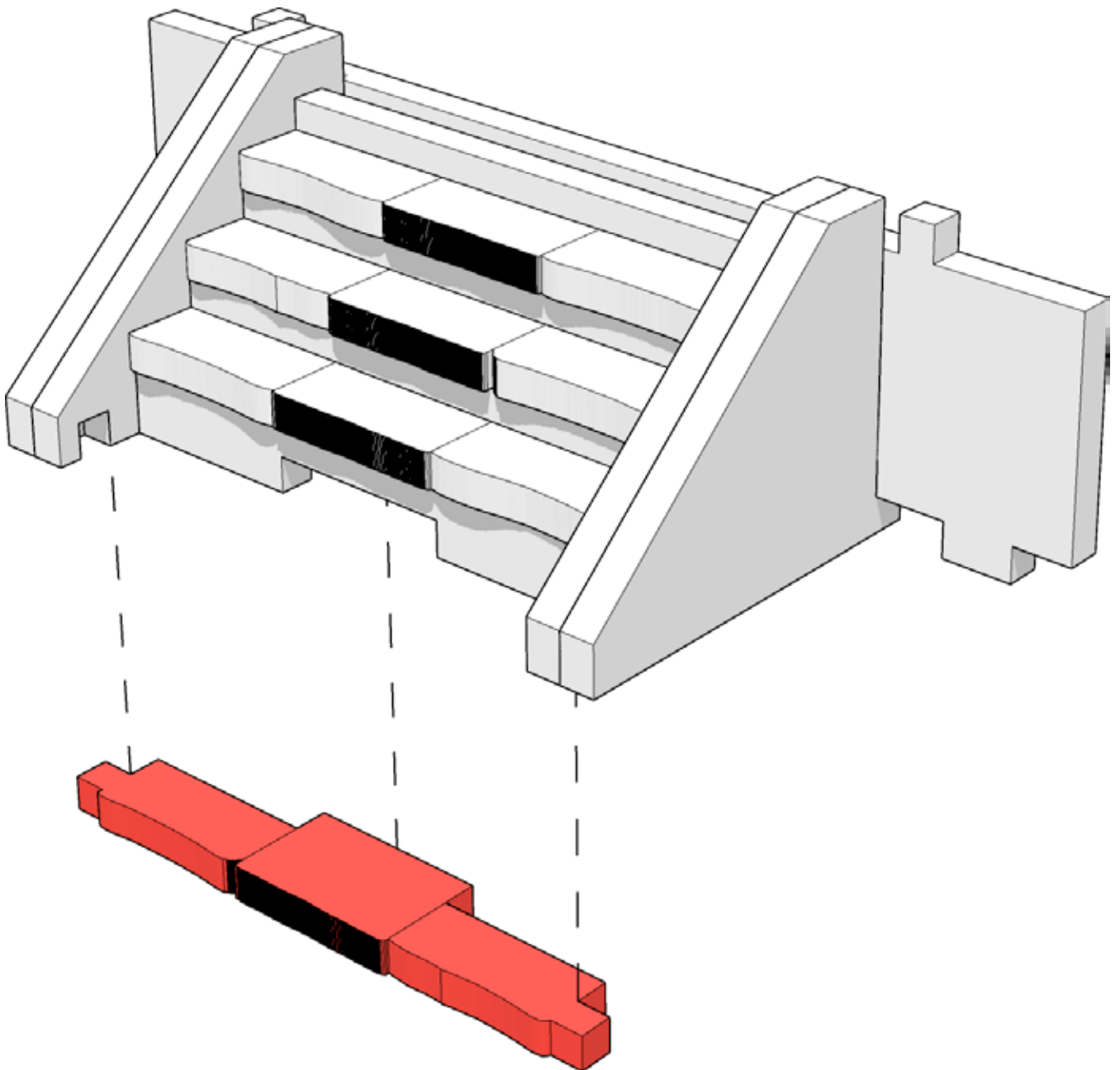



TABLETOP SCENICS

TTSCW-EES-110
Toshi
Hakkei-tō Pagoda

76

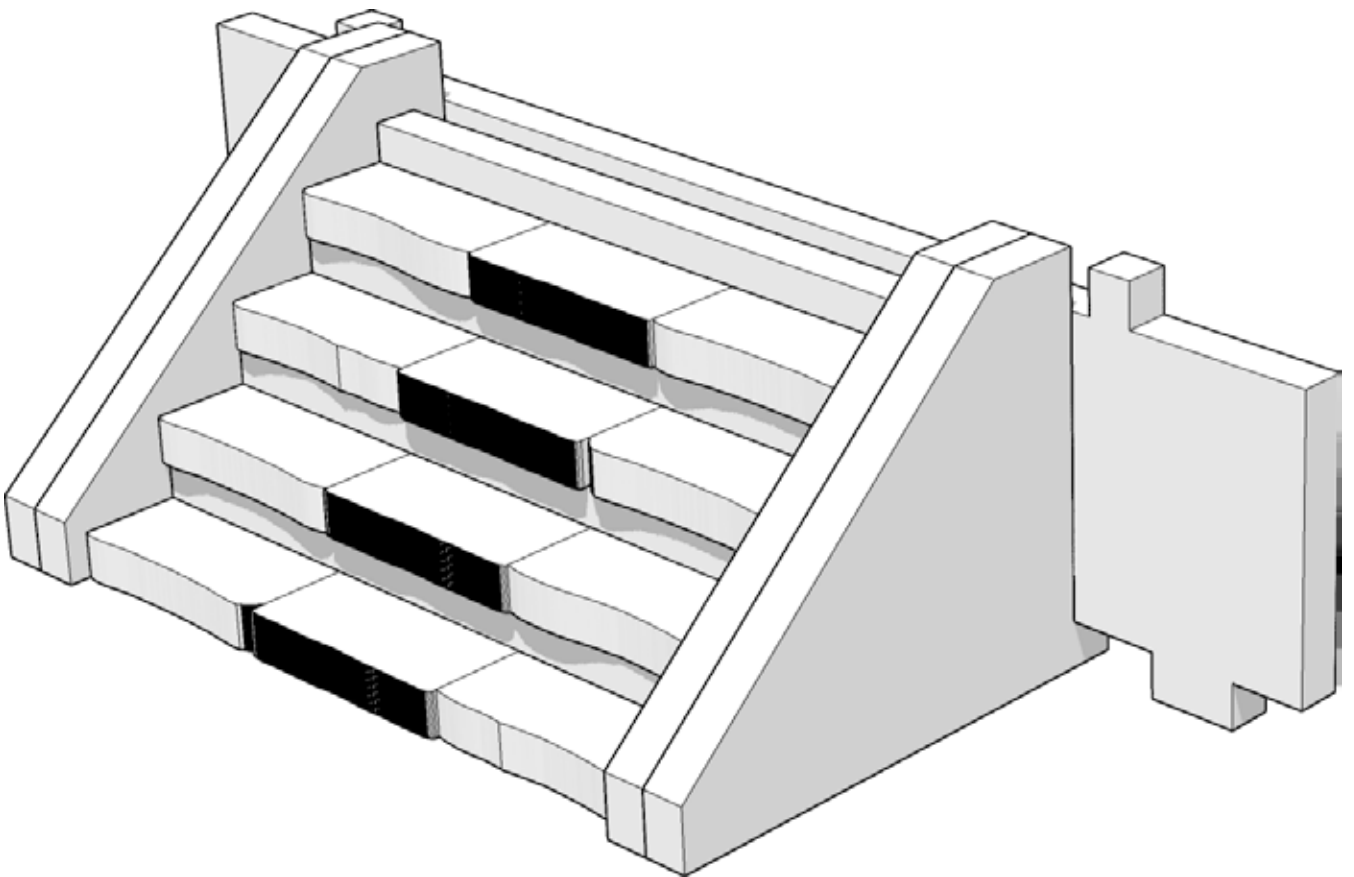

x4

 TTCOMBAT



TABLETOP SCENICS

TTSCW-EES-110
Toshi
Hakkei-tō Pagoda

77

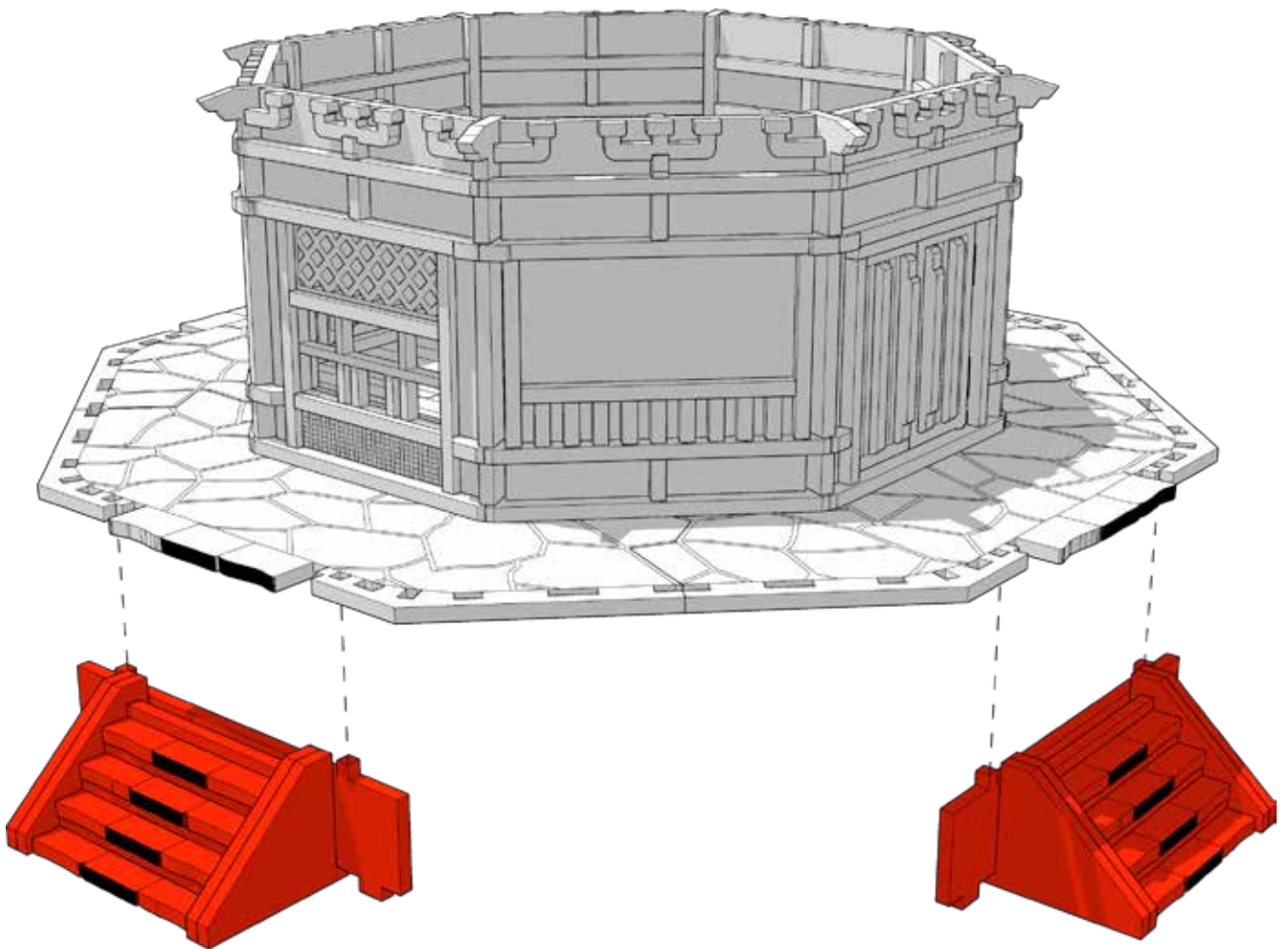



TABLETOP SCENICS

78

TTSCW-EES-110
Toshi
Hakkei-tō Pagoda

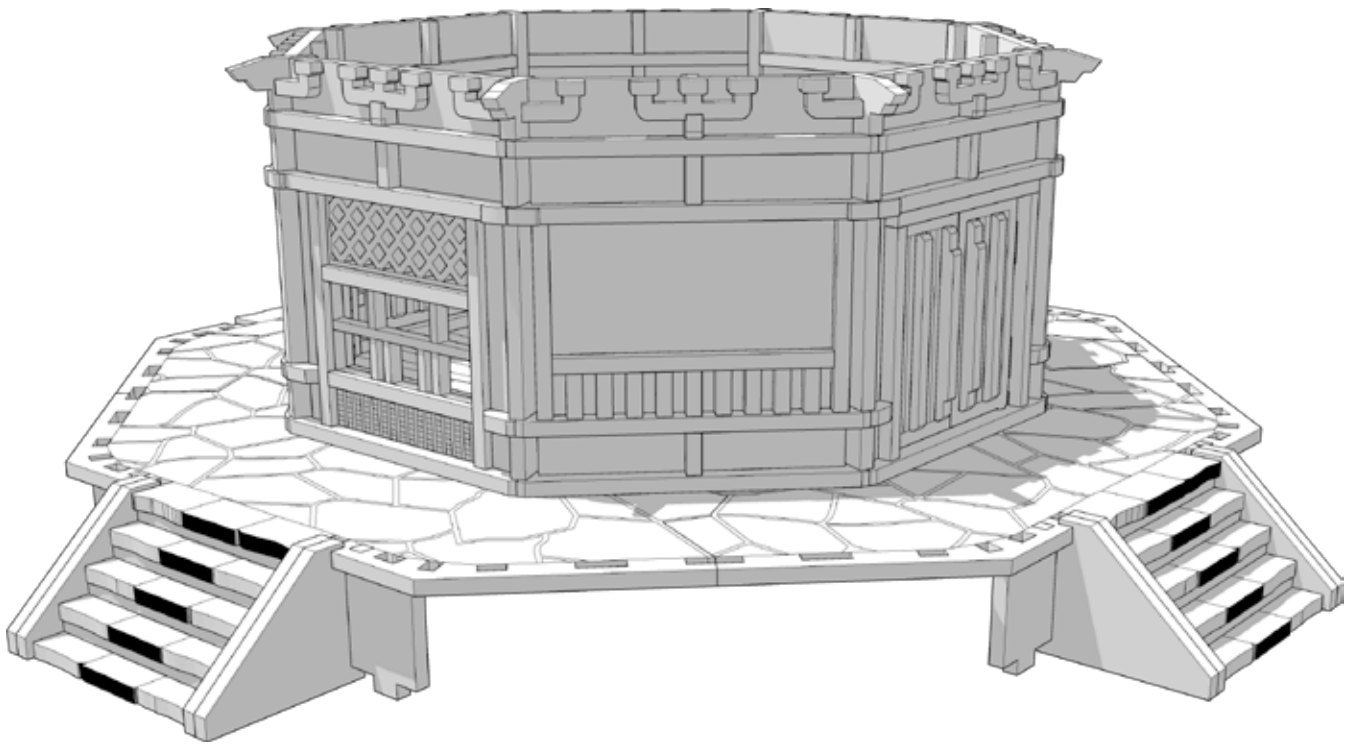



TABLETOP SCENICS

TTSCW-EES-110
Toshi
Hakkei-tō Pagoda

79

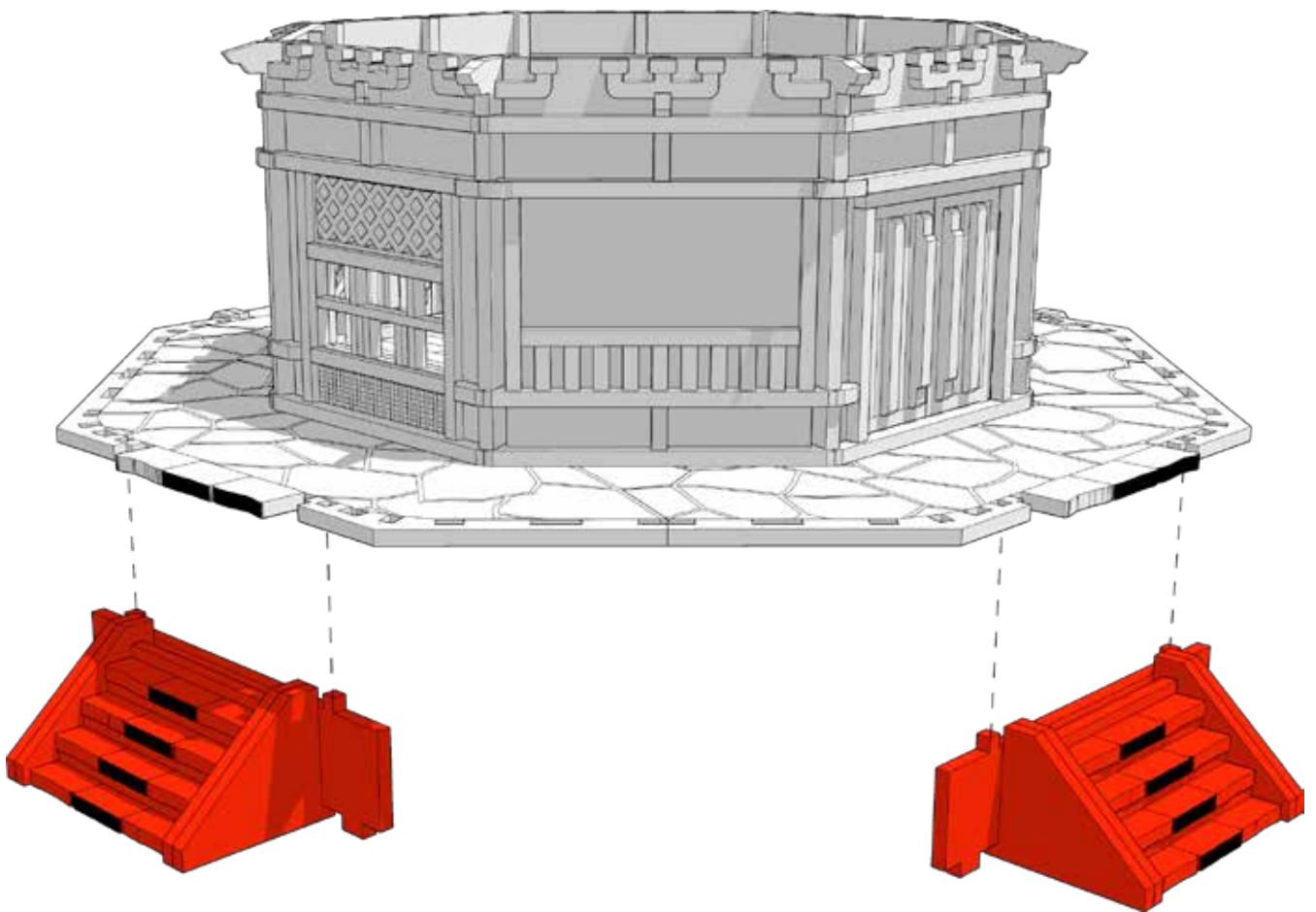



TABLETOP SCENICS

TTSCW-EES-110
Toshi
Hakkei-tō Pagoda

80

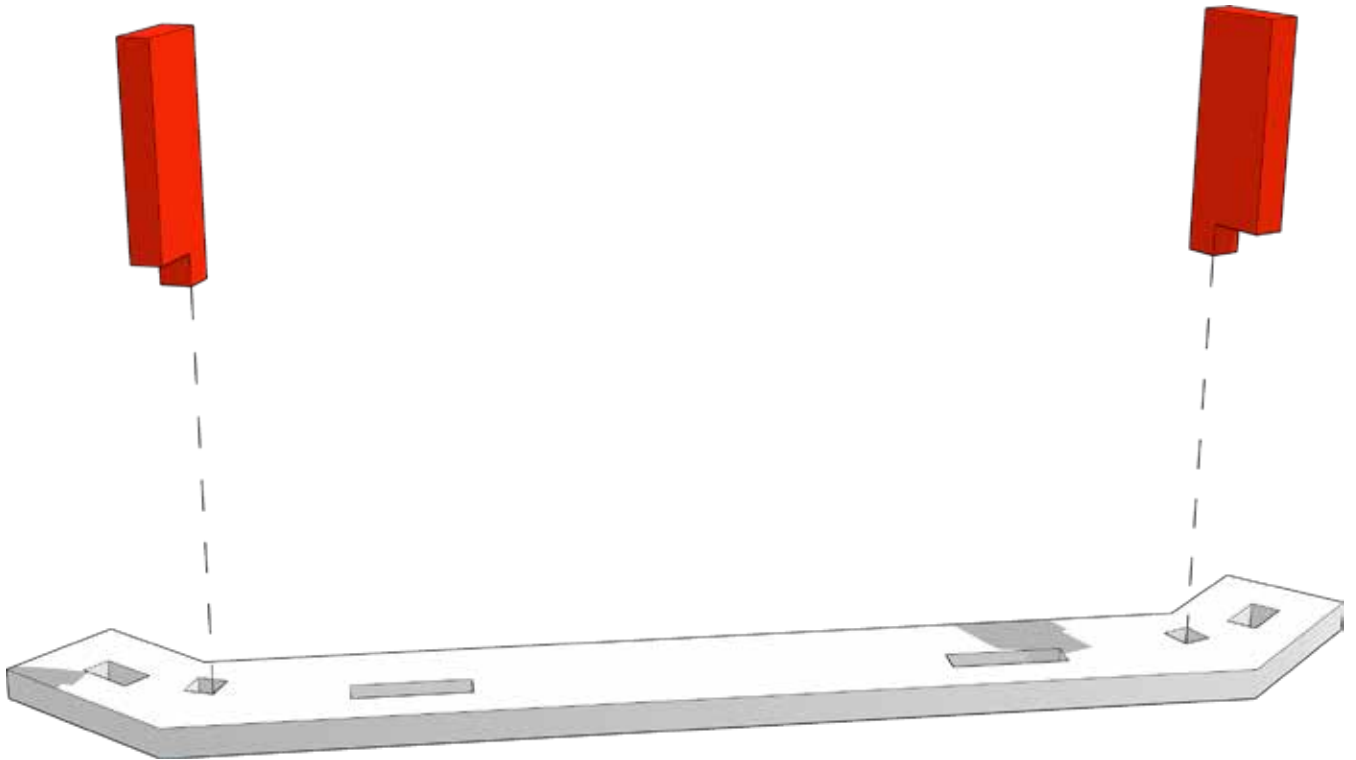



TABLETOP SCENICS

TTSCW-EES-110
Toshi
Hakkei-tō Pagoda

81

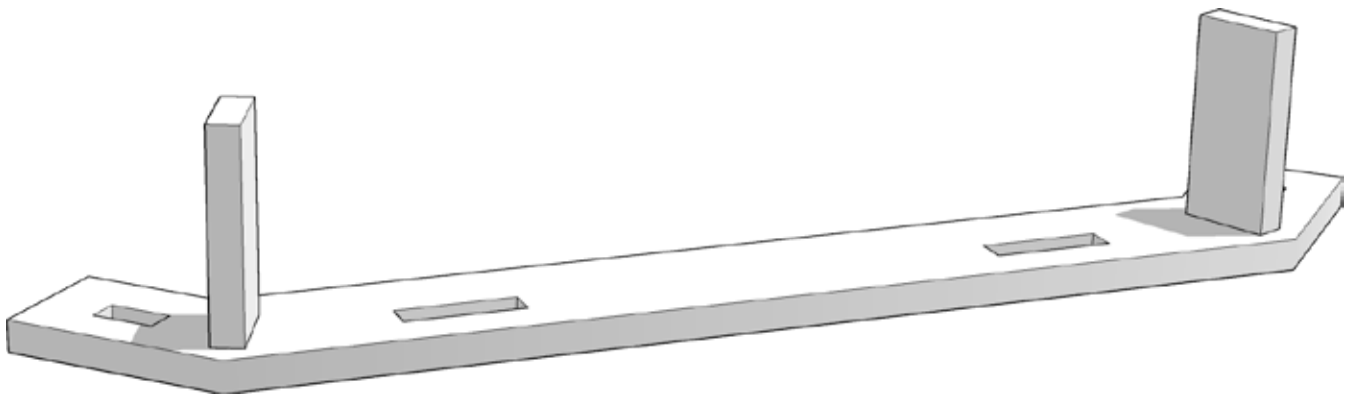

x4



TABLETOP SCENICS

TTSCW-EES-110
Toshi
Hakkei-tō Pagoda

82

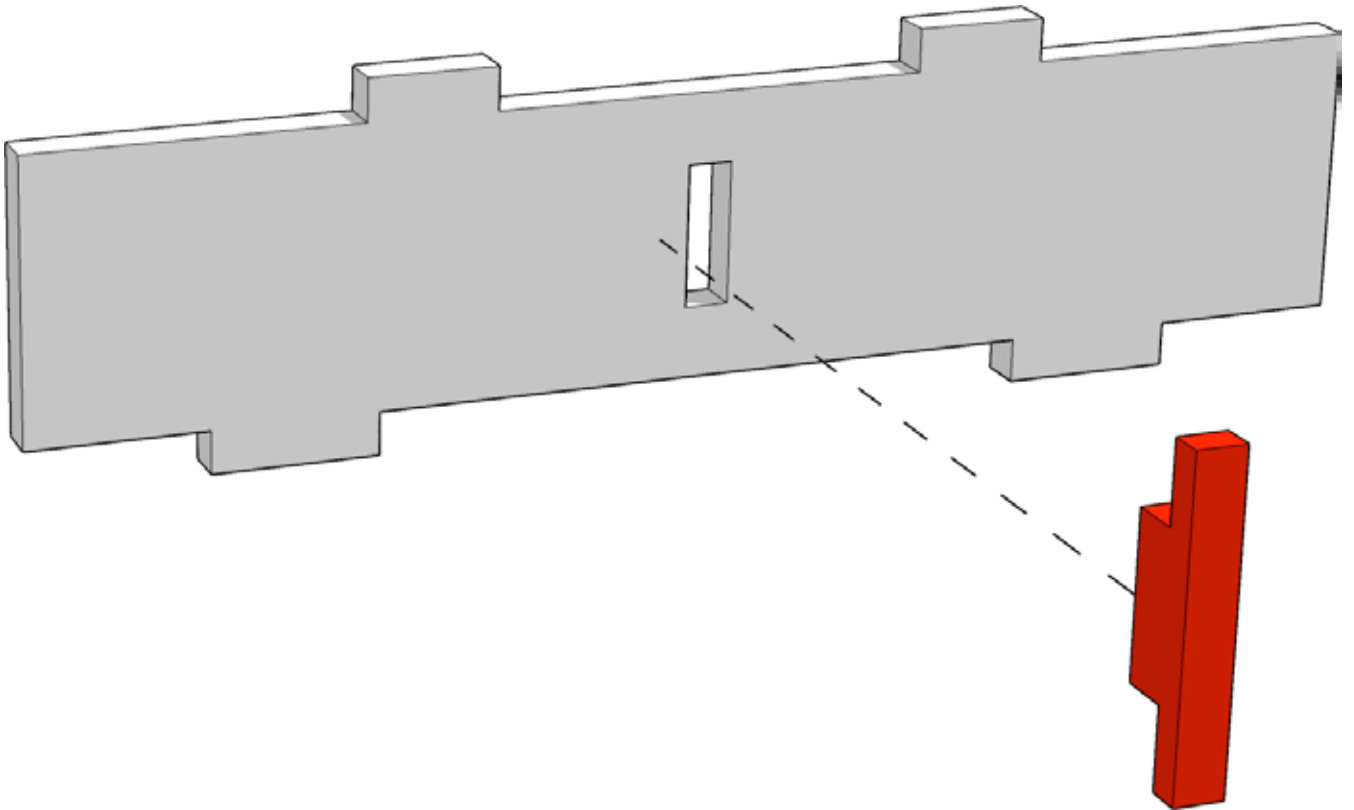



TABLETOP SCENICS

TTSCW-EES-110
Toshi
Hakkei-tō Pagoda

83

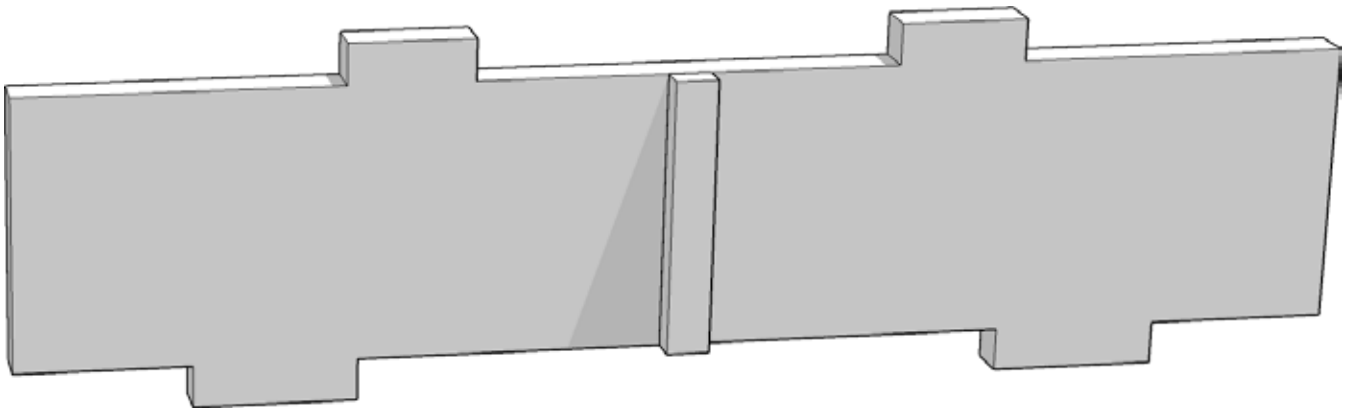



TABLETOP SCENICS

TTSCW-EES-110
Toshi
Hakkei-tō Pagoda

84

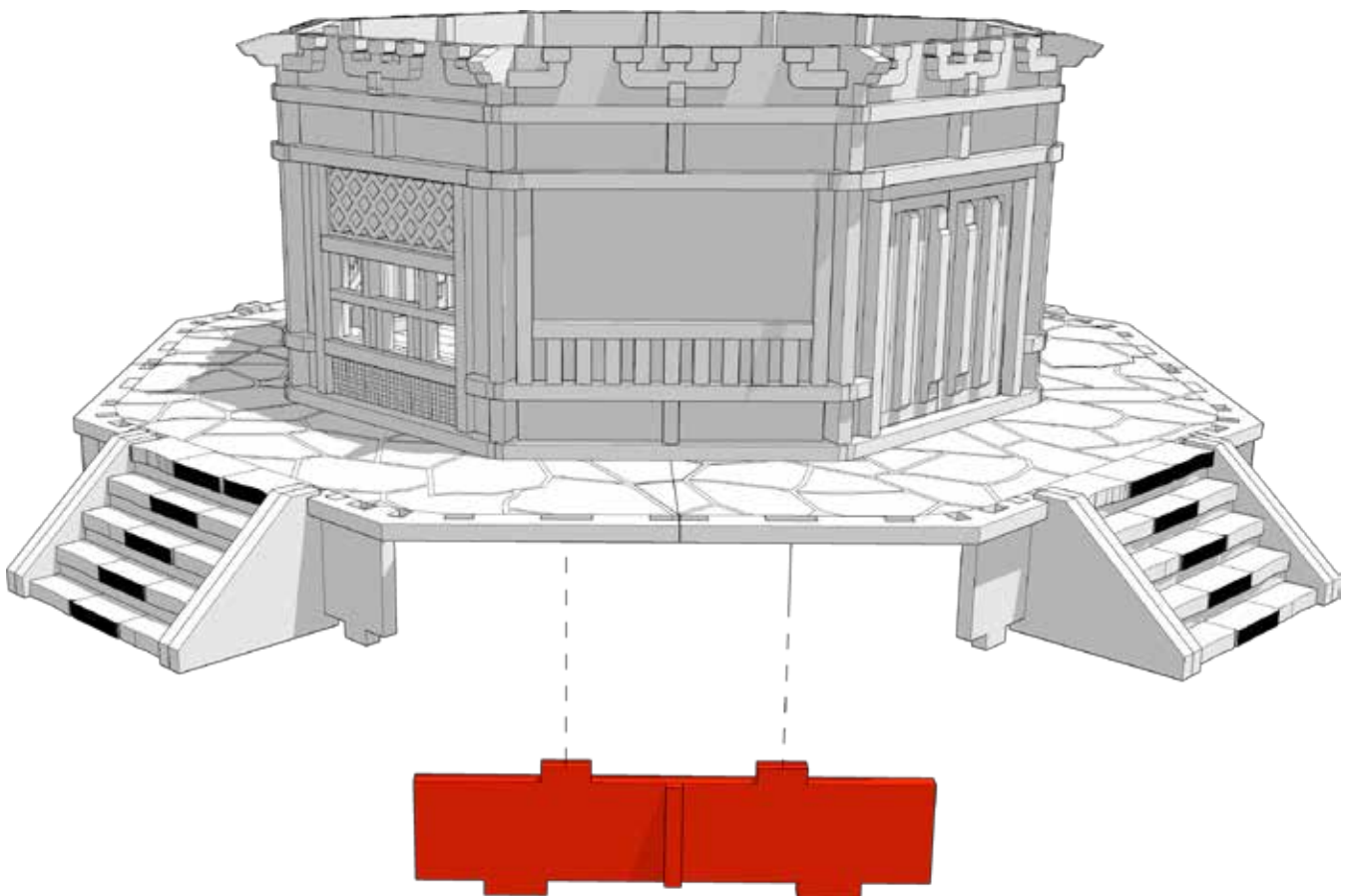



TABLETOP SCENICS

TTSCW-EES-110
Toshi
Hakkei-tō Pagoda

85

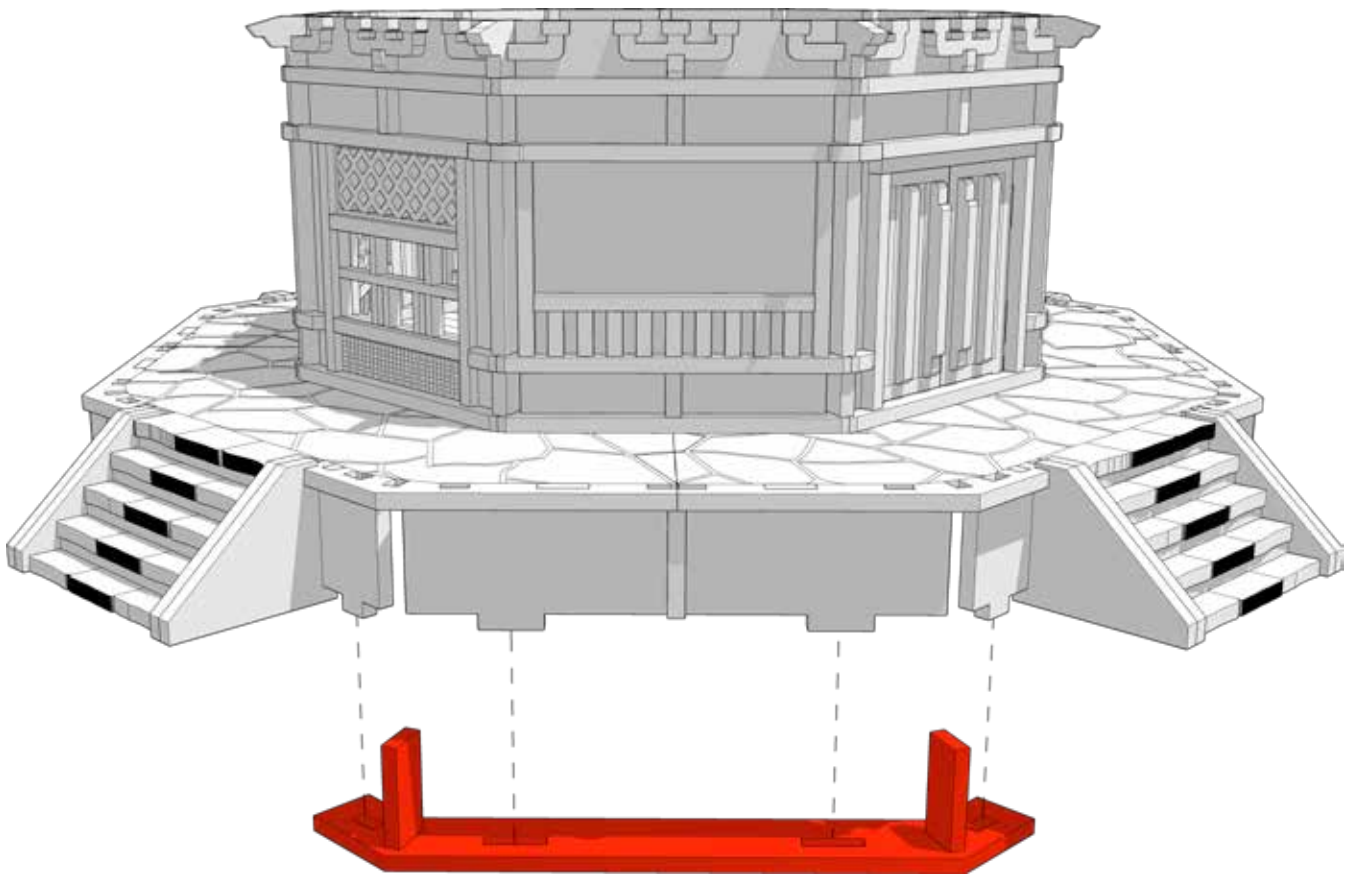



TABLETOP SCENICS

TTSCW-EES-110
Toshi
Hakkei-tō Pagoda

86

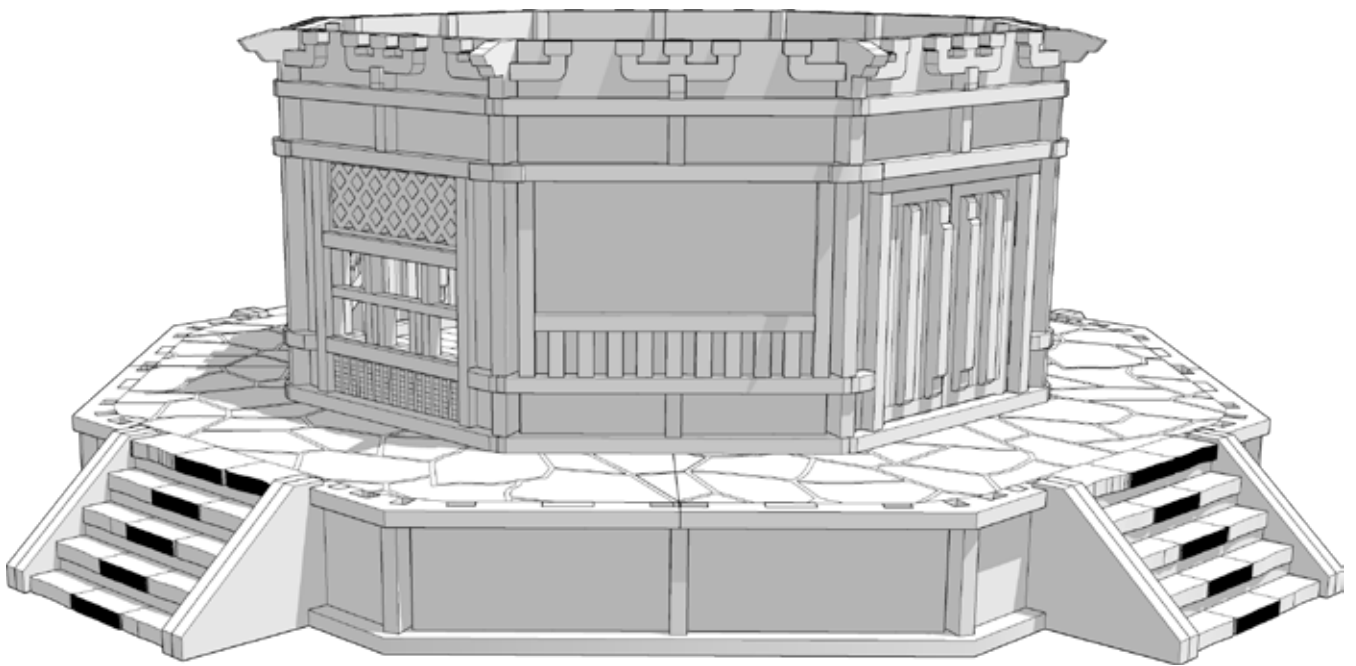

Repeat steps 72 & 73 for remaining sides



TABLETOP SCENICS

TTSCW-EES-110
Toshi
Hakkei-tō Pagoda

87

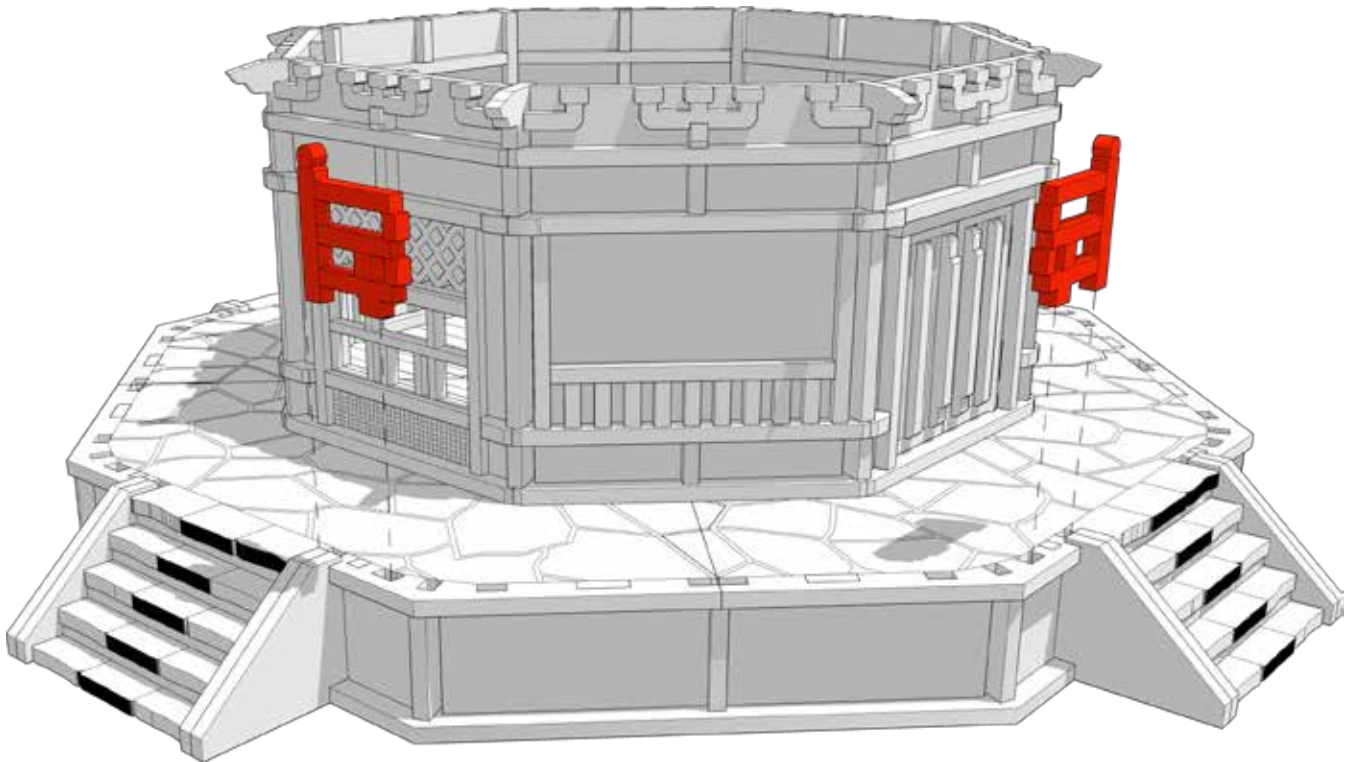



TABLETOP SCENICS

TTSCW-EES-110
Toshi
Hakkei-tō Pagoda

88

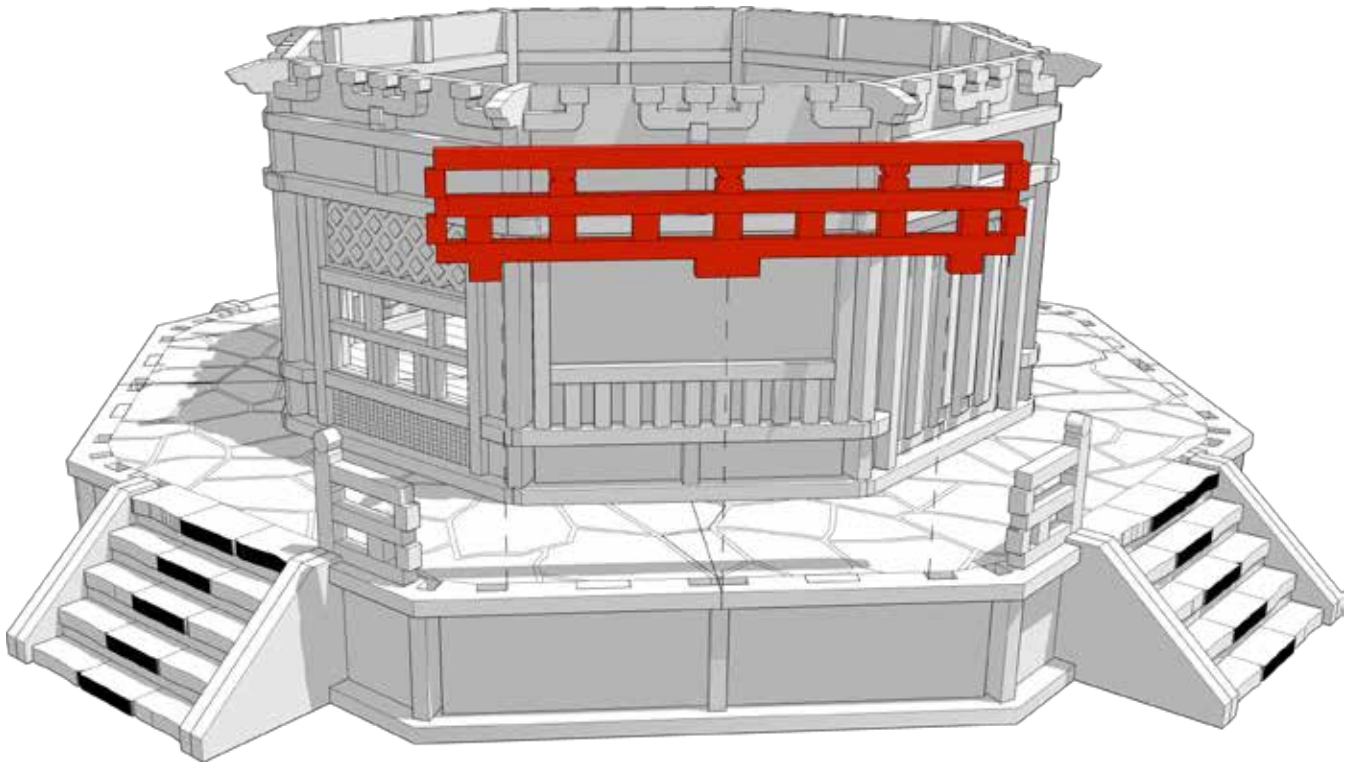



TABLETOP SCENICS

TTSCW-EES-110
Toshi
Hakkei-tō Pagoda

89

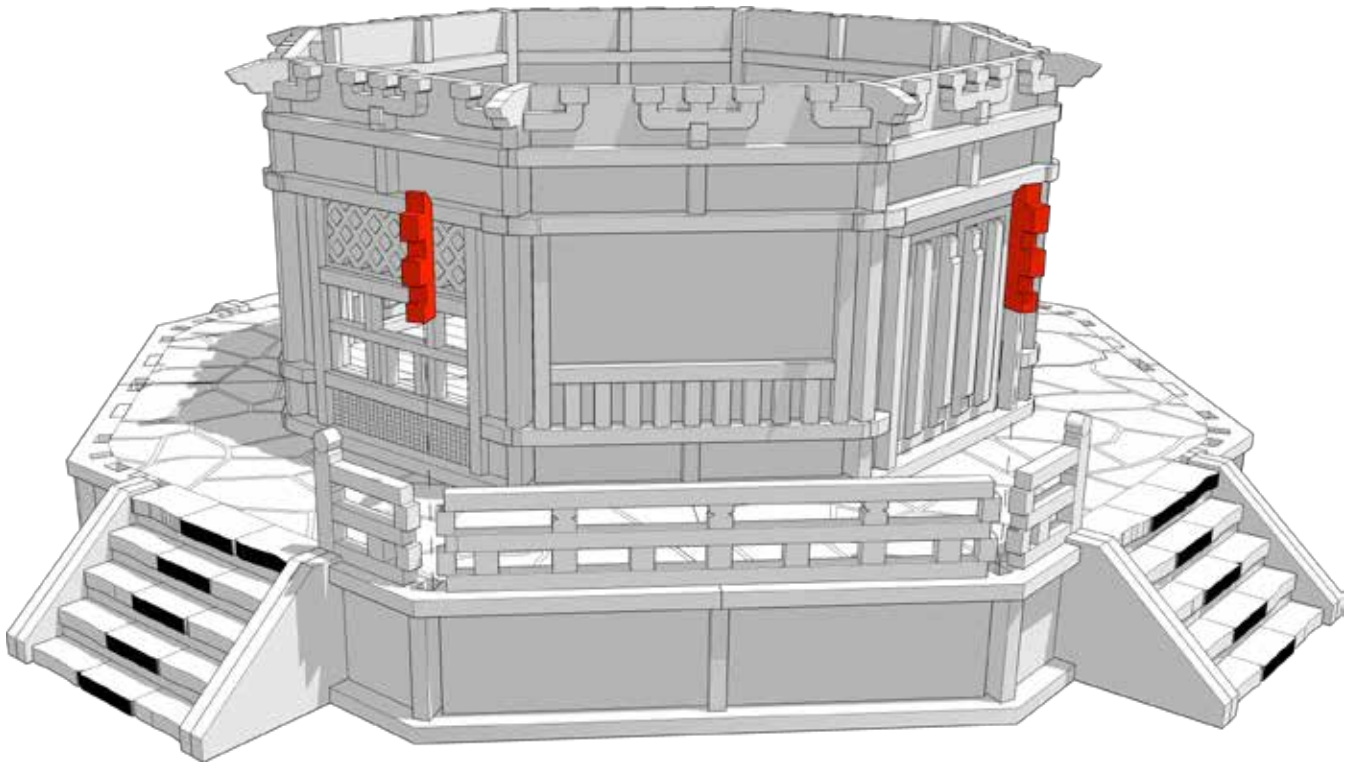



TABLETOP SCENICS

TTSCW-EES-110
Toshi
Hakkei-tō Pagoda

90

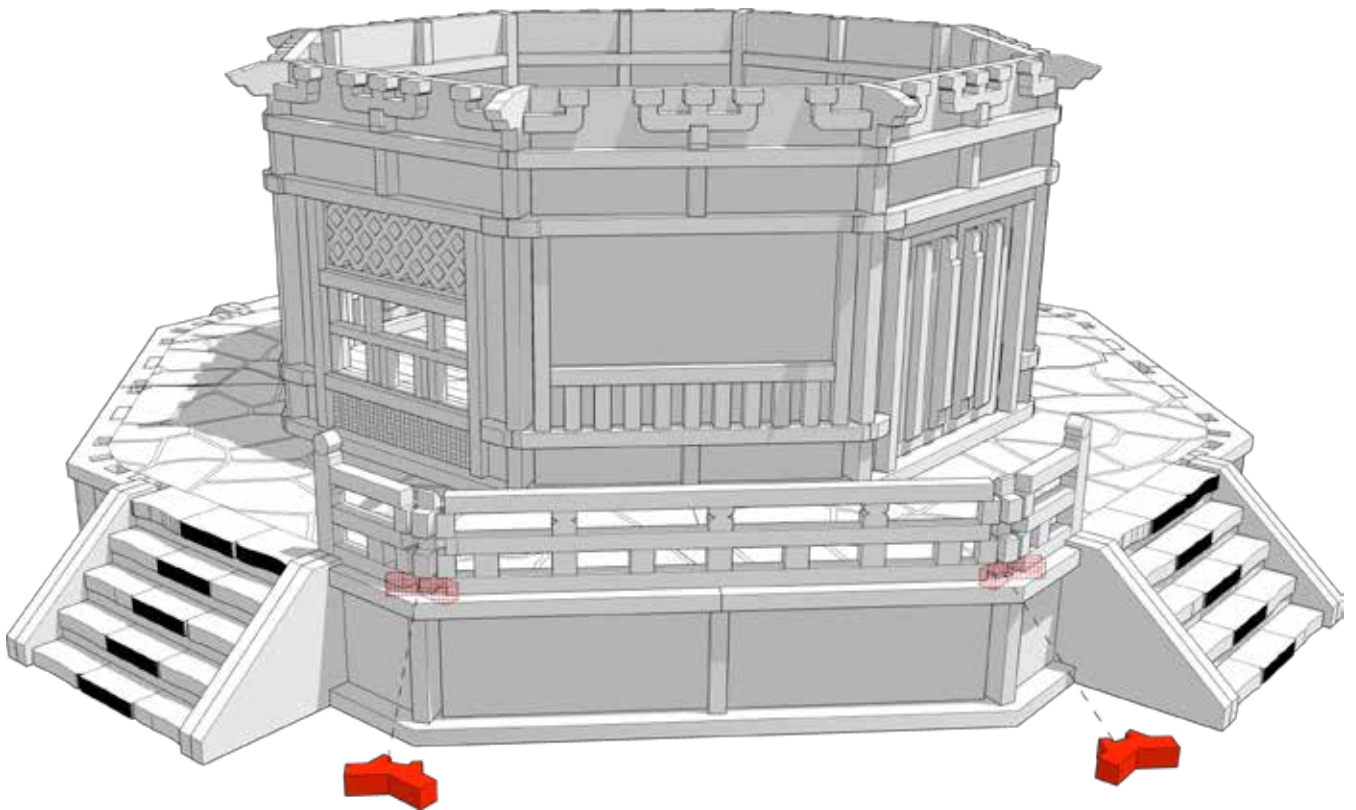



TABLETOP SCENICS

TTSCW-EES-110
Toshi
Hakkei-tō Pagoda

91

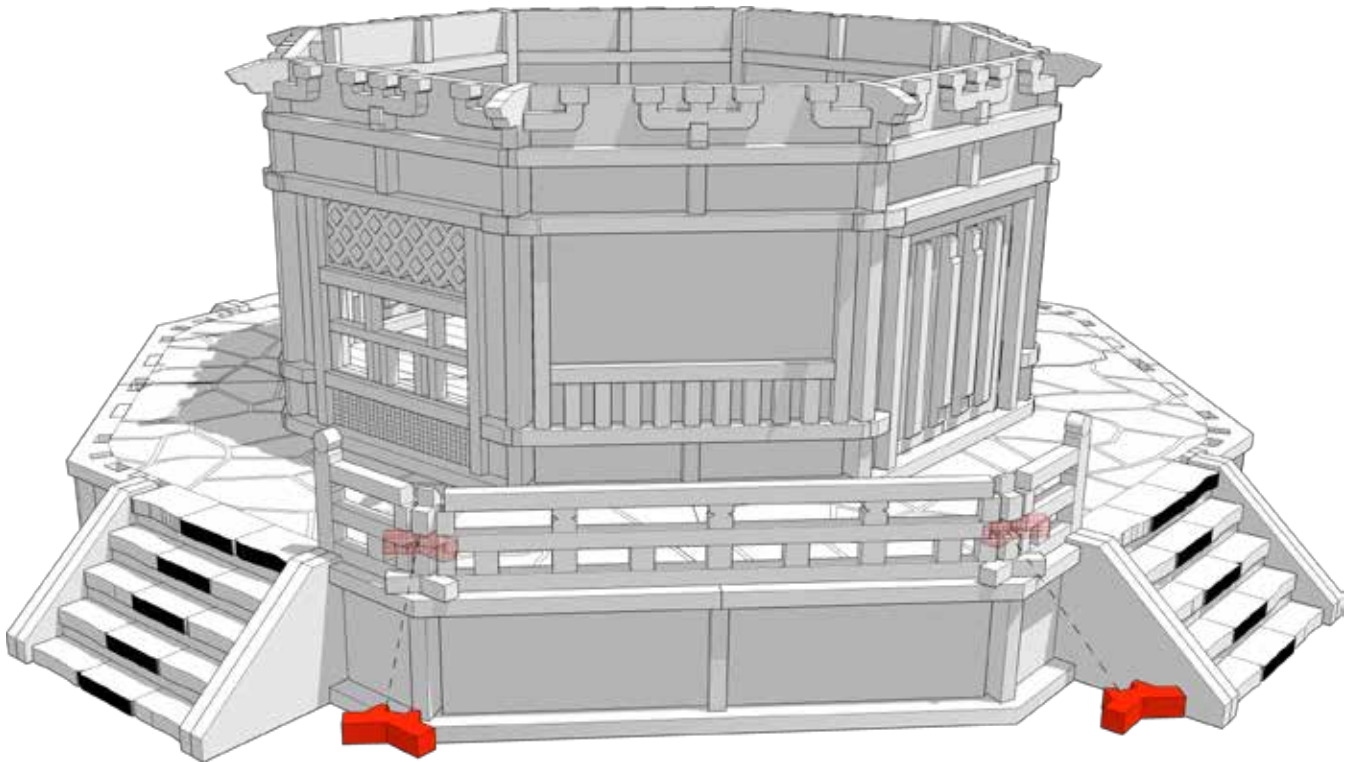



TABLETOP SCENICS

TTSCW-EES-110
Toshi
Hakkei-tō Pagoda

92

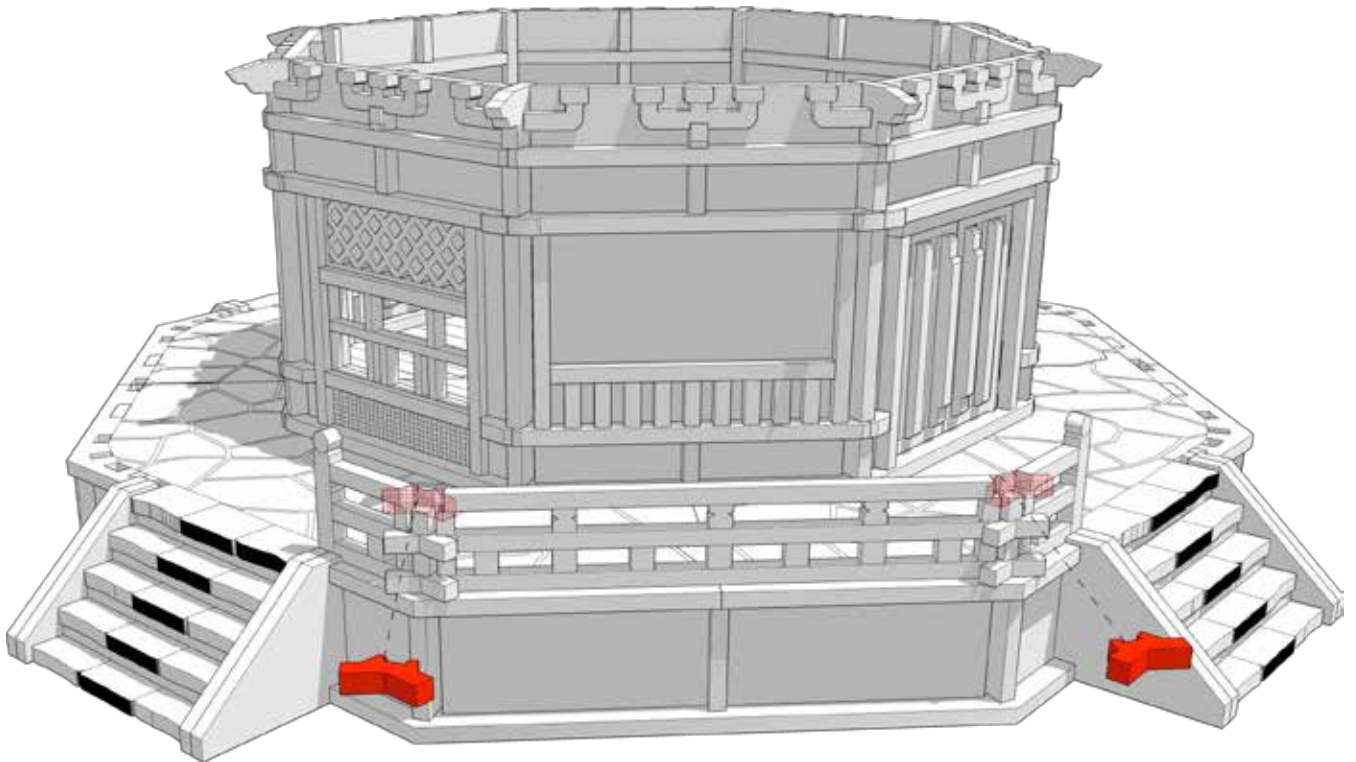



TABLETOP SCENICS

TTSCW-EES-110
Toshi
Hakkei-tō Pagoda

93

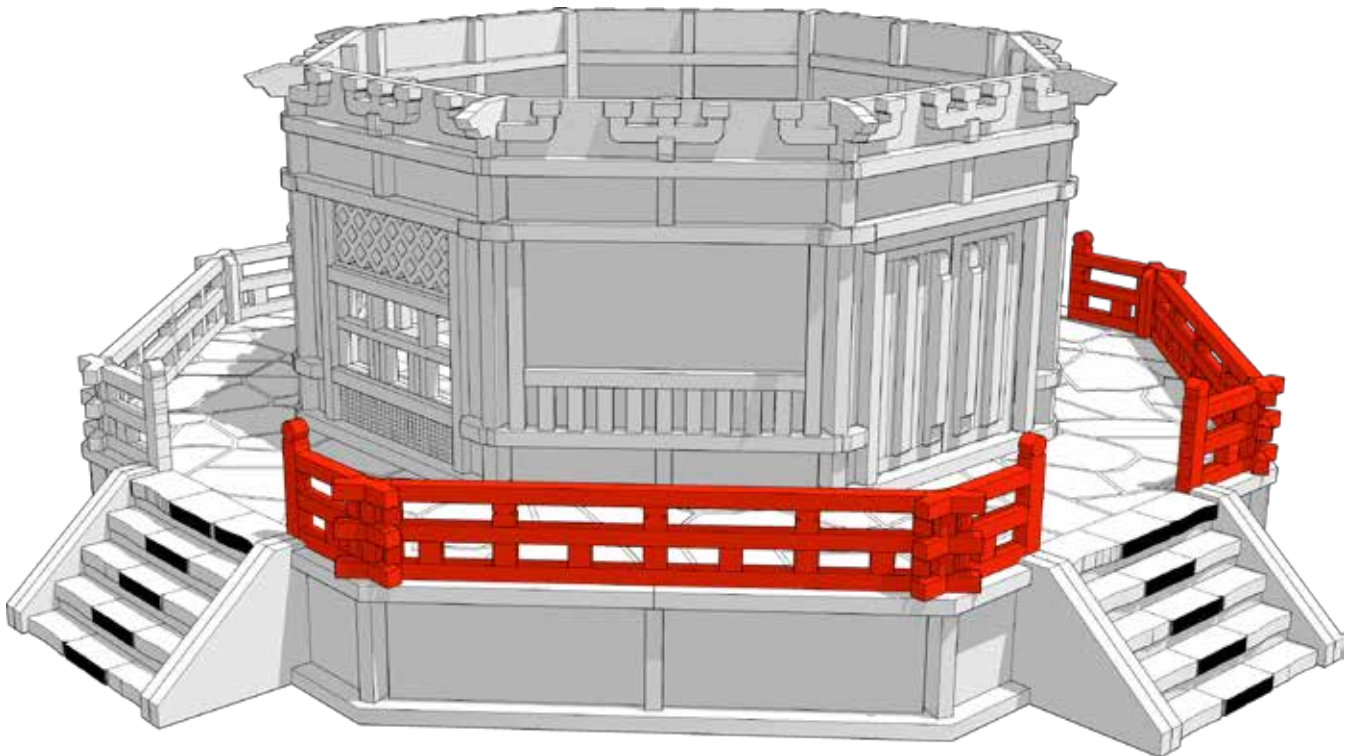

Repeats steps 75-80 for the remaining sides



TABLETOP SCENICS

TTSCW-EES-110
Toshi
Hakkei-tō Pagoda

94

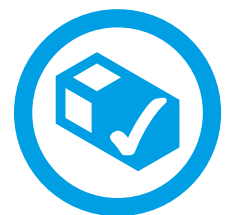
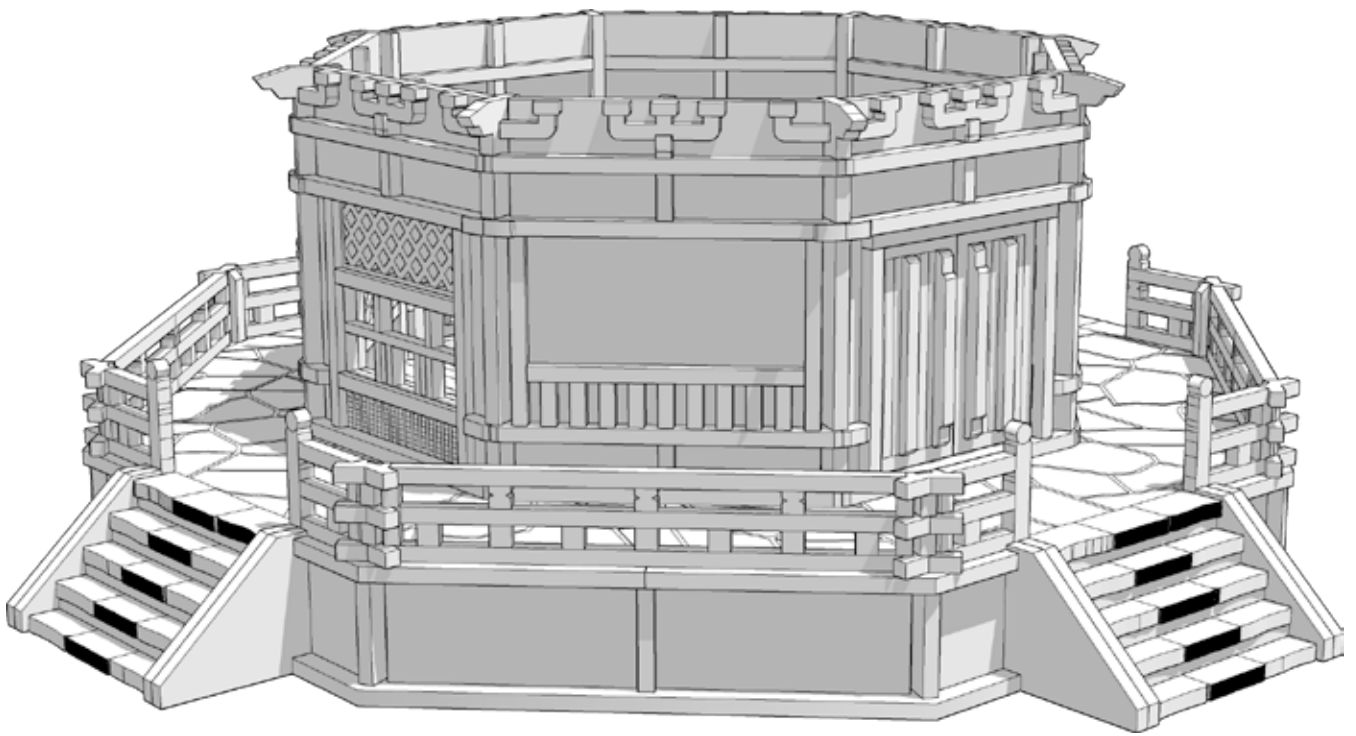



TABLETOP SCENICS

TTSCW-EES-110
Toshi
Hakkei-tō Pagoda

95

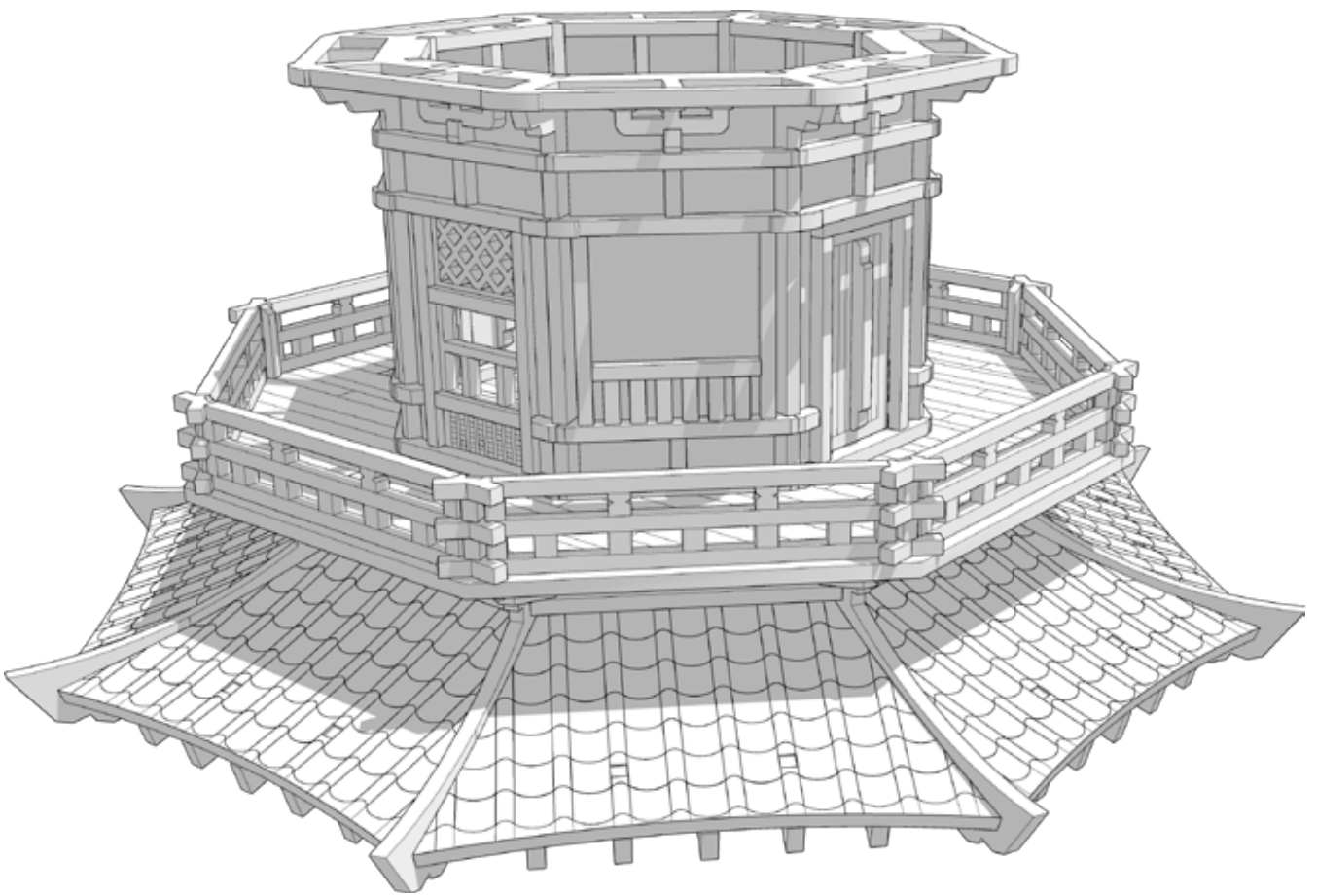

Enclosed Extension





TABLETOP SCENICS

TTSCW-EES-110
Toshi
Hakkei-tō Pagoda

96

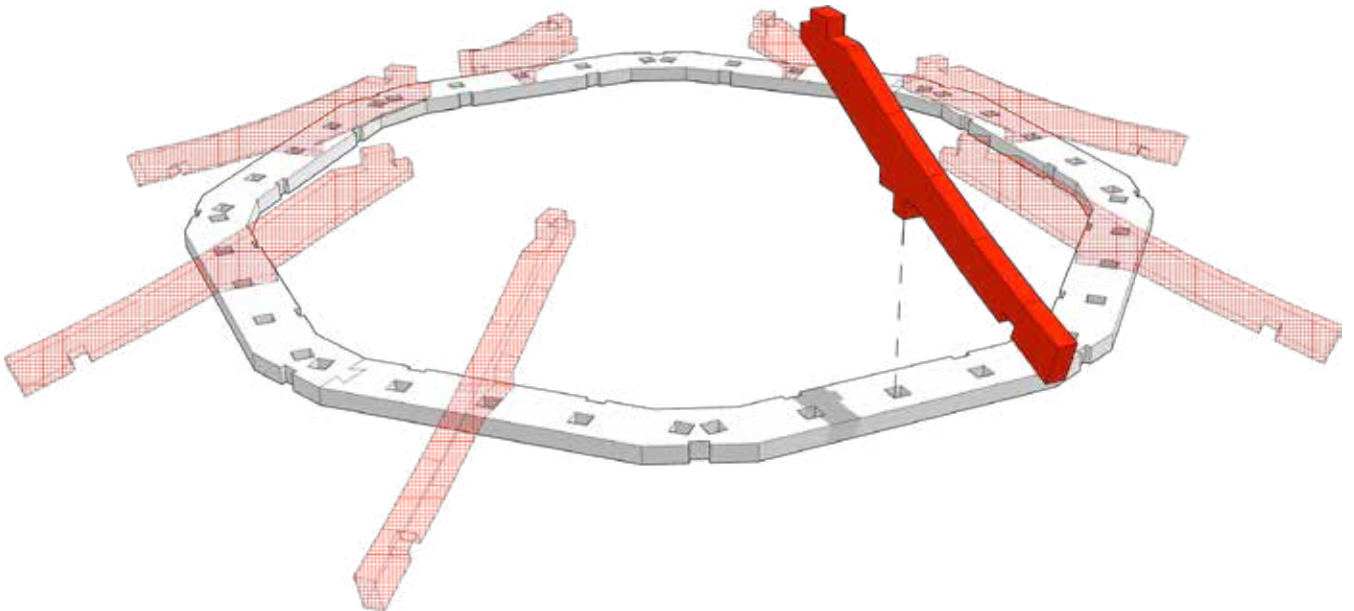

PVA recommended for this stage of the roof to allow for some movement during construction





TABLETOP SCENICS

TTSCW-EES-110
Toshi
Hakkei-tō Pagoda

97

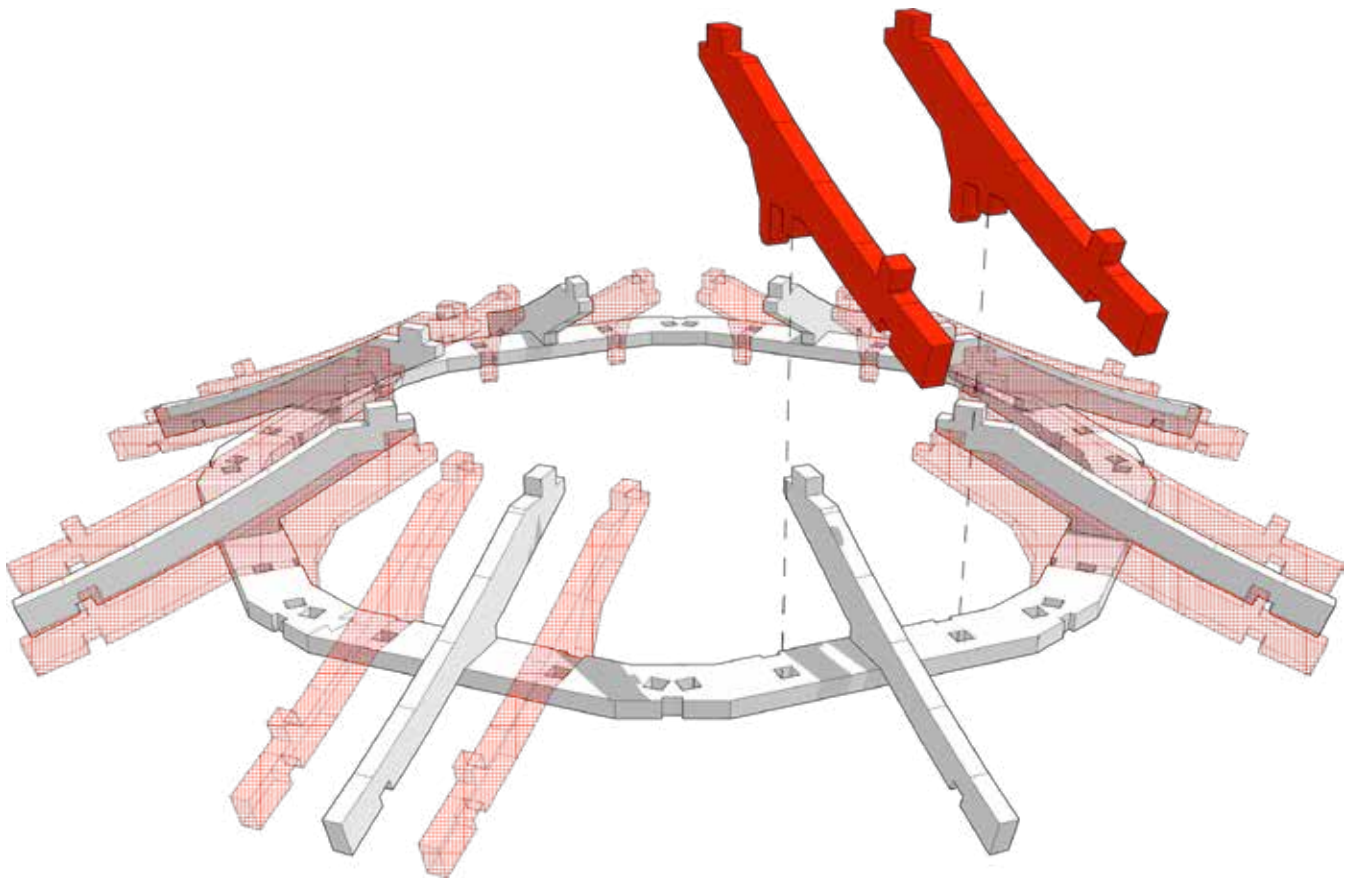



TABLETOP SCENICS

TTSCW-EES-110
Toshi
Hakkei-tō Pagoda

98

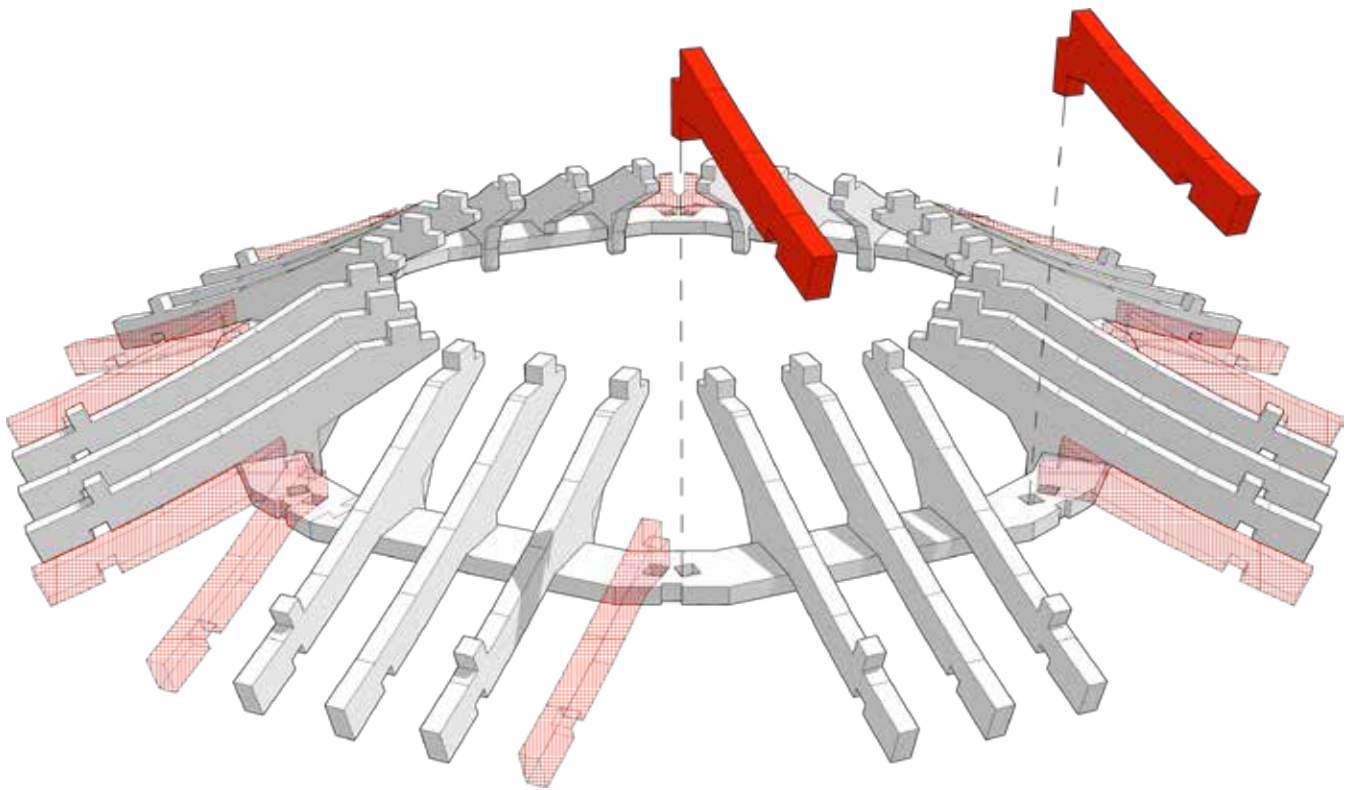



TABLETOP SCENICS

TTSCW-EES-110
Toshi
Hakkei-tō Pagoda

99

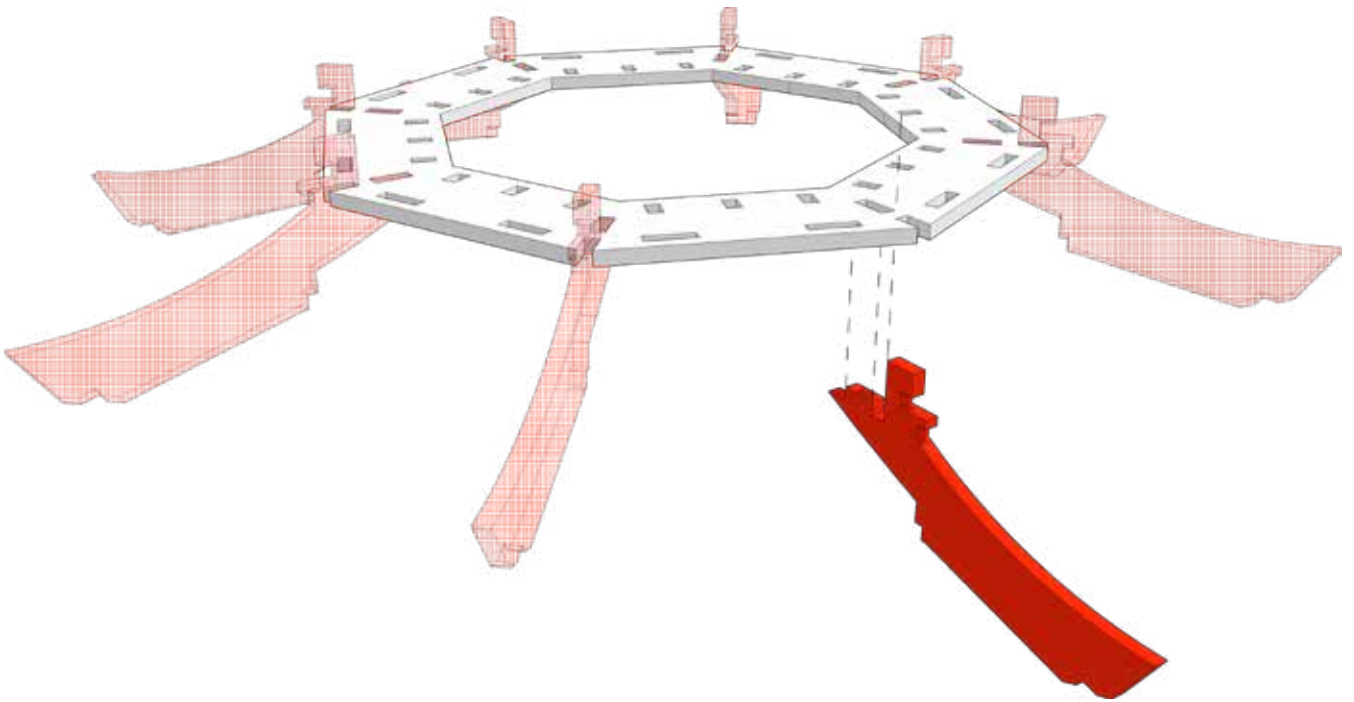



TABLETOP SCENICS

100

TTSCW-EES-110
Toshi
Hakkei-tō Pagoda

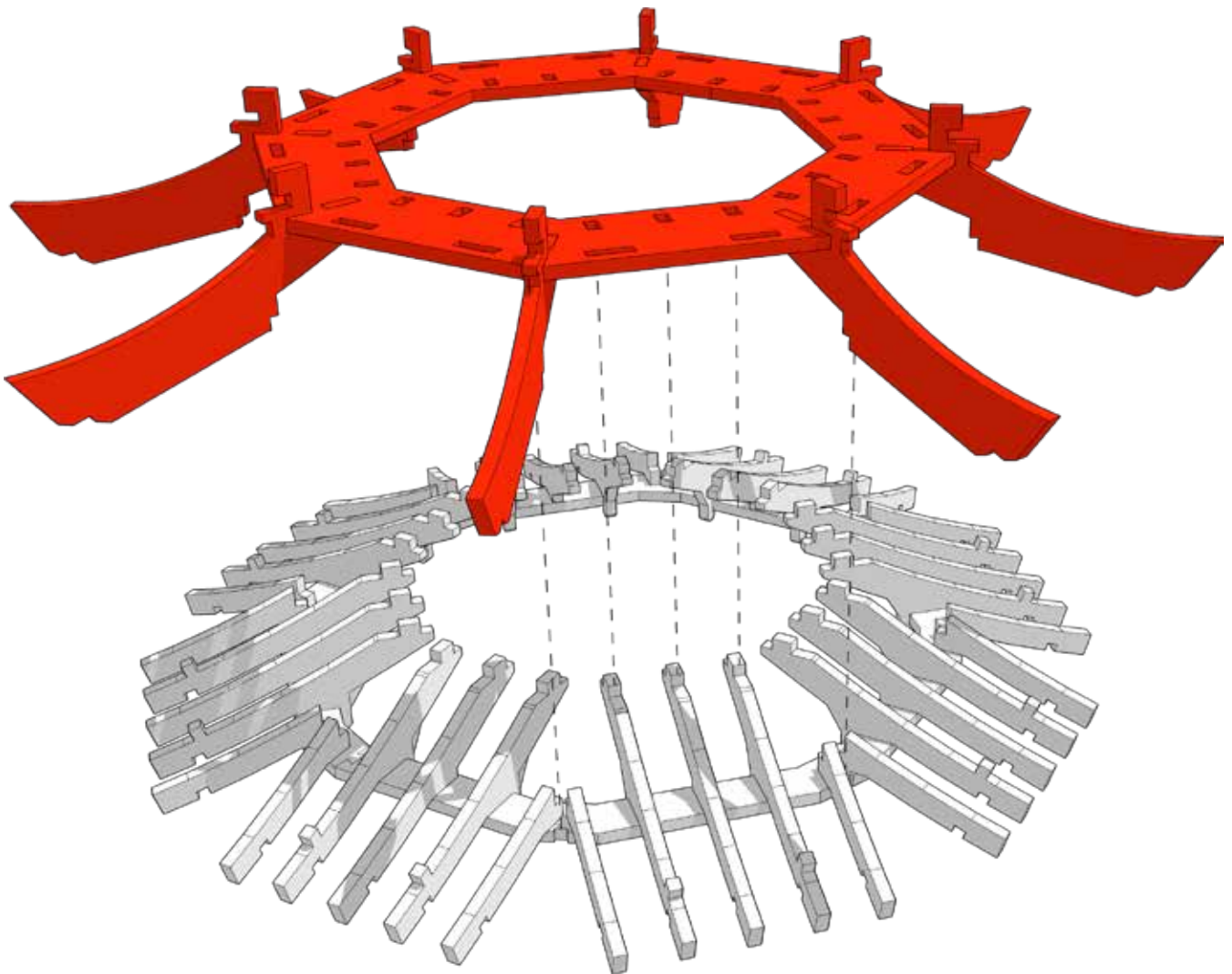

It is likely parts will pop out as you progressively slot this on. Be sure to check all parts are fully in place before glue dries.





TABLETOP SCENICS

101

TTSCW-EES-110
Toshi
Hakkei-tō Pagoda

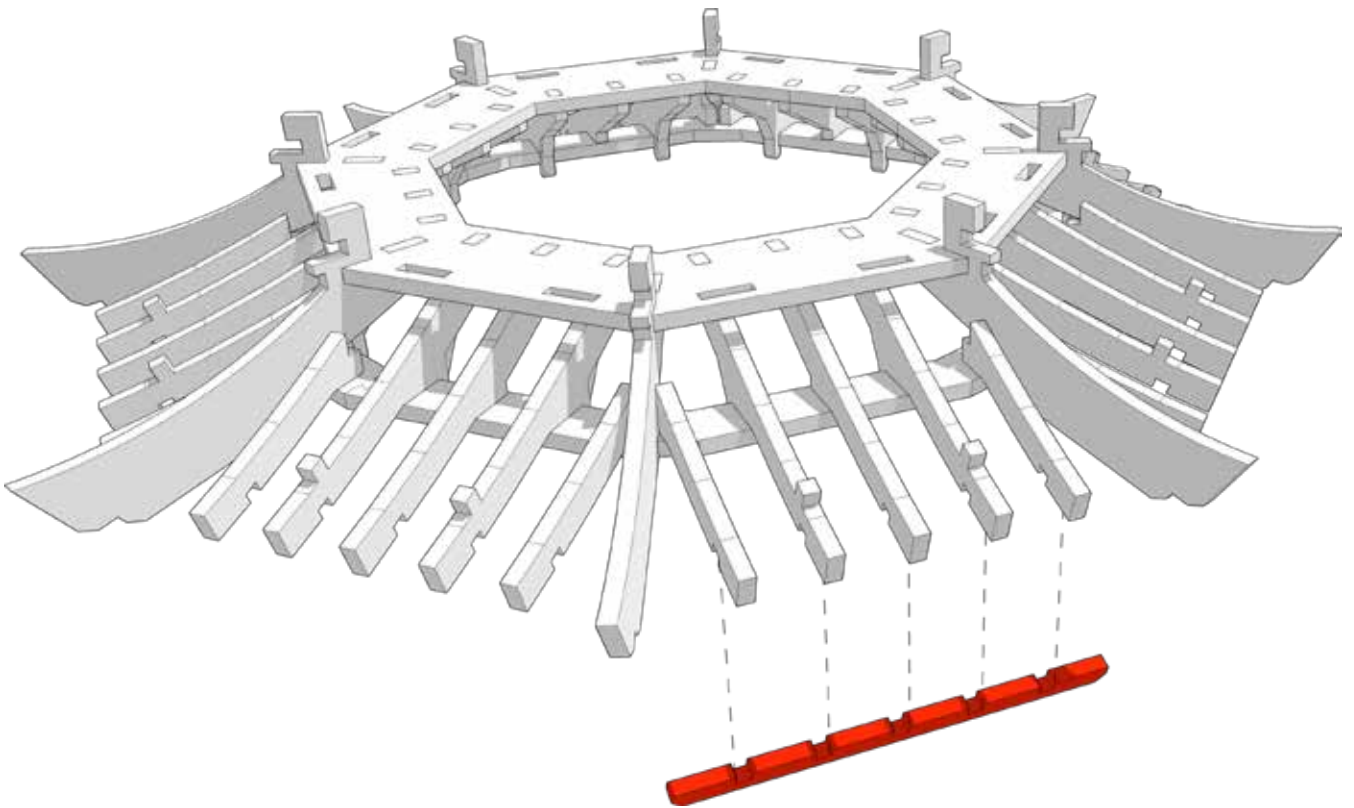



TABLETOP SCENICS

TTSCW-EES-110
Toshi
Hakkei-tō Pagoda

102

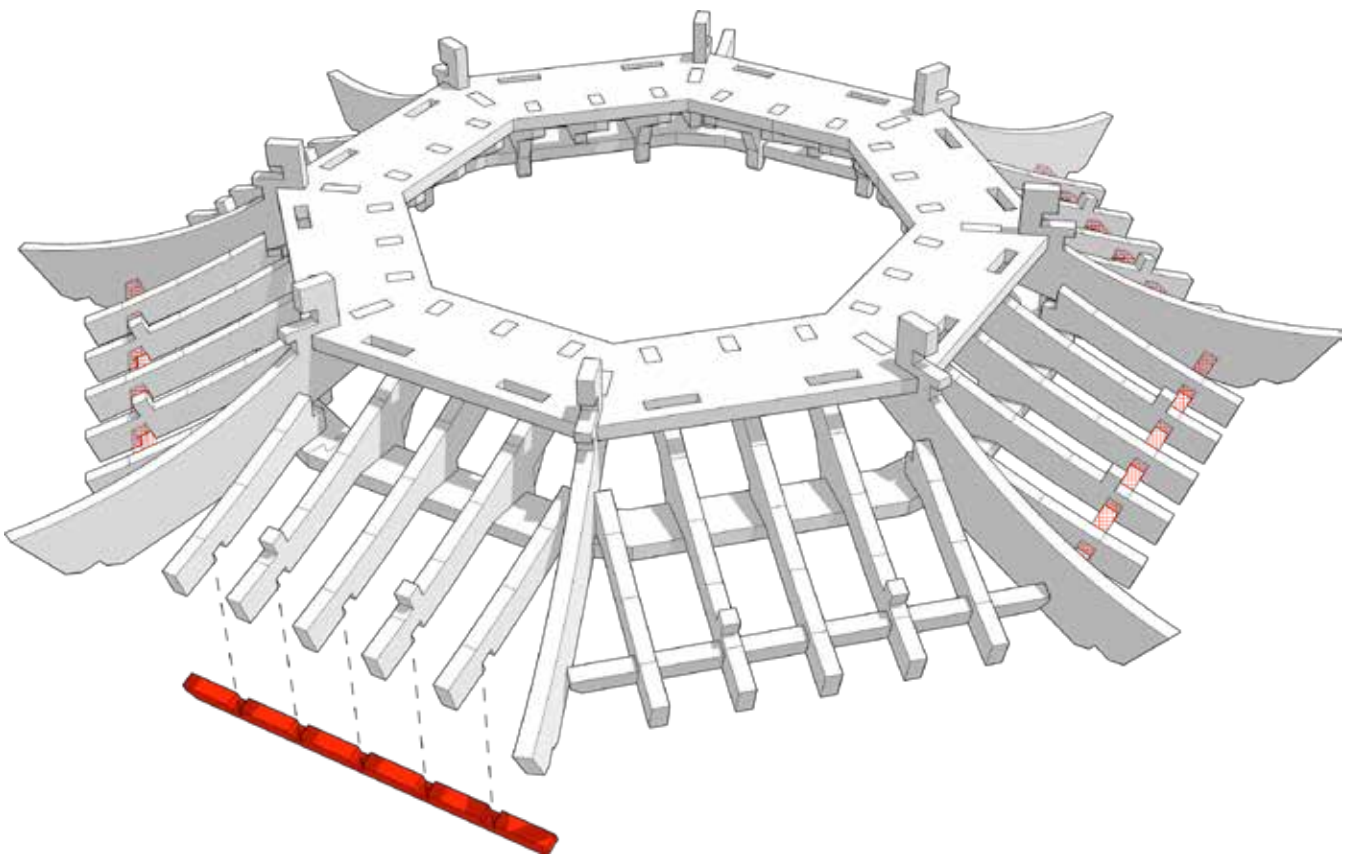

Repeat step for all remaining sides



TABLETOP SCENICS

TTSCW-EES-110
Toshi
Hakkei-tō Pagoda

103

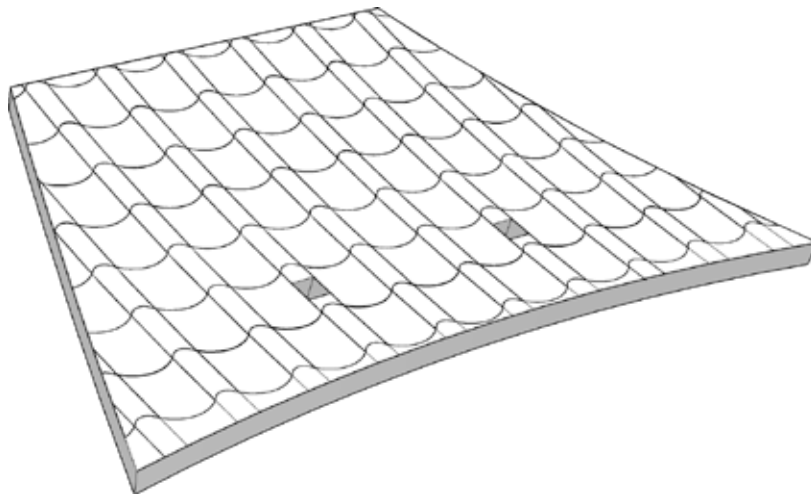

FRAGILE

Over bending will cause this to break

Do not bend freely



TABLETOP SCENICS

TTSCW-EES-110
Toshi
Hakkei-tō Pagoda

104

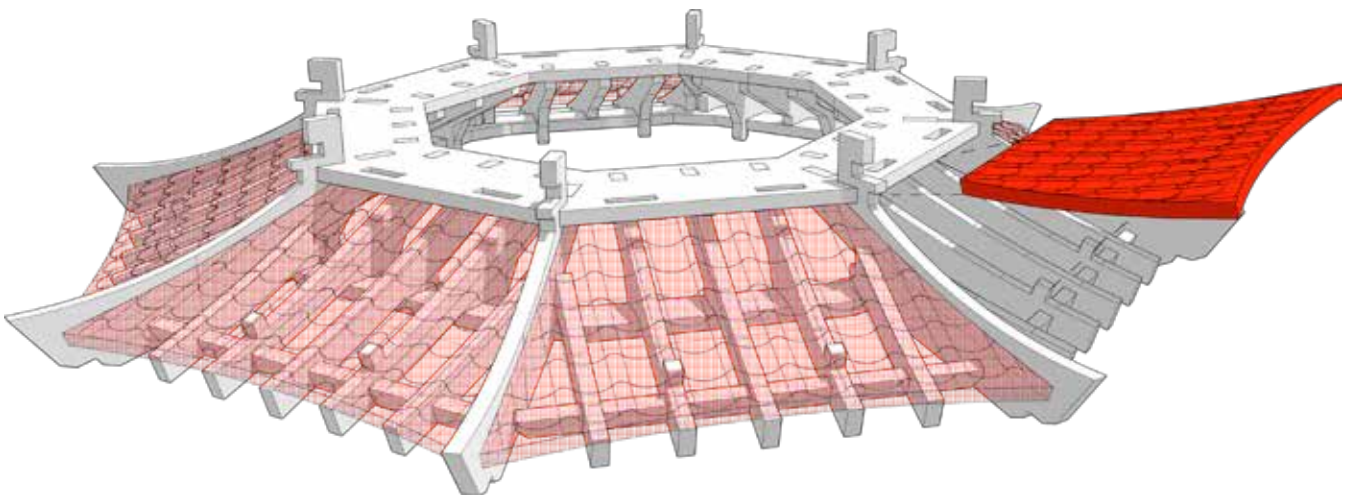

Roof sits under the larger hexagon part. Slot into place and align the tabs and push down. Using superglue or a fast drying glue is recommended. Repeat around the roof.



TABLETOP SCENICS

105

TTSCW-EES-110
Toshi
Hakkei-tō Pagoda

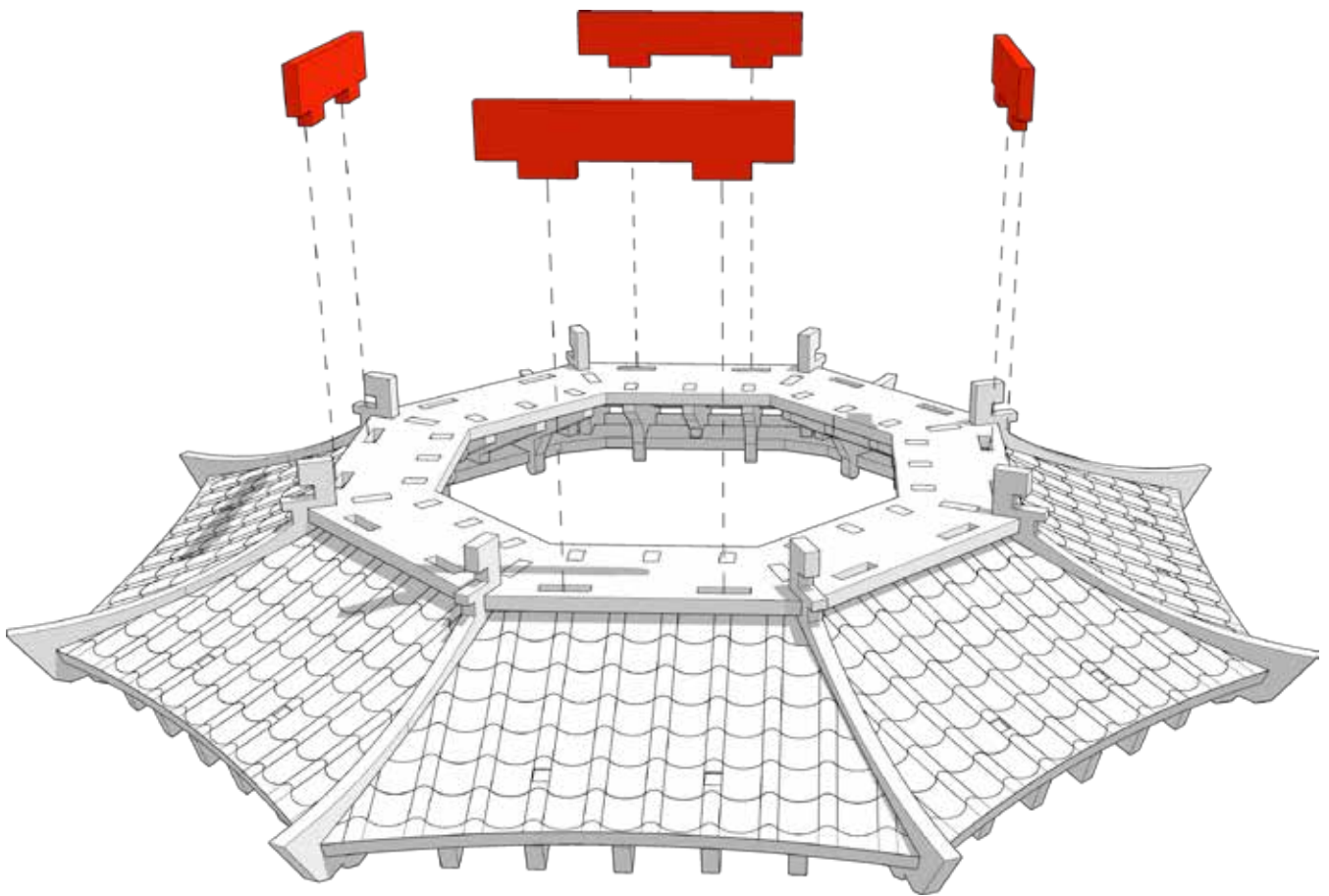



TABLETOP SCENICS

106

TTSCW-EES-110
Toshi
Hakkei-tō Pagoda

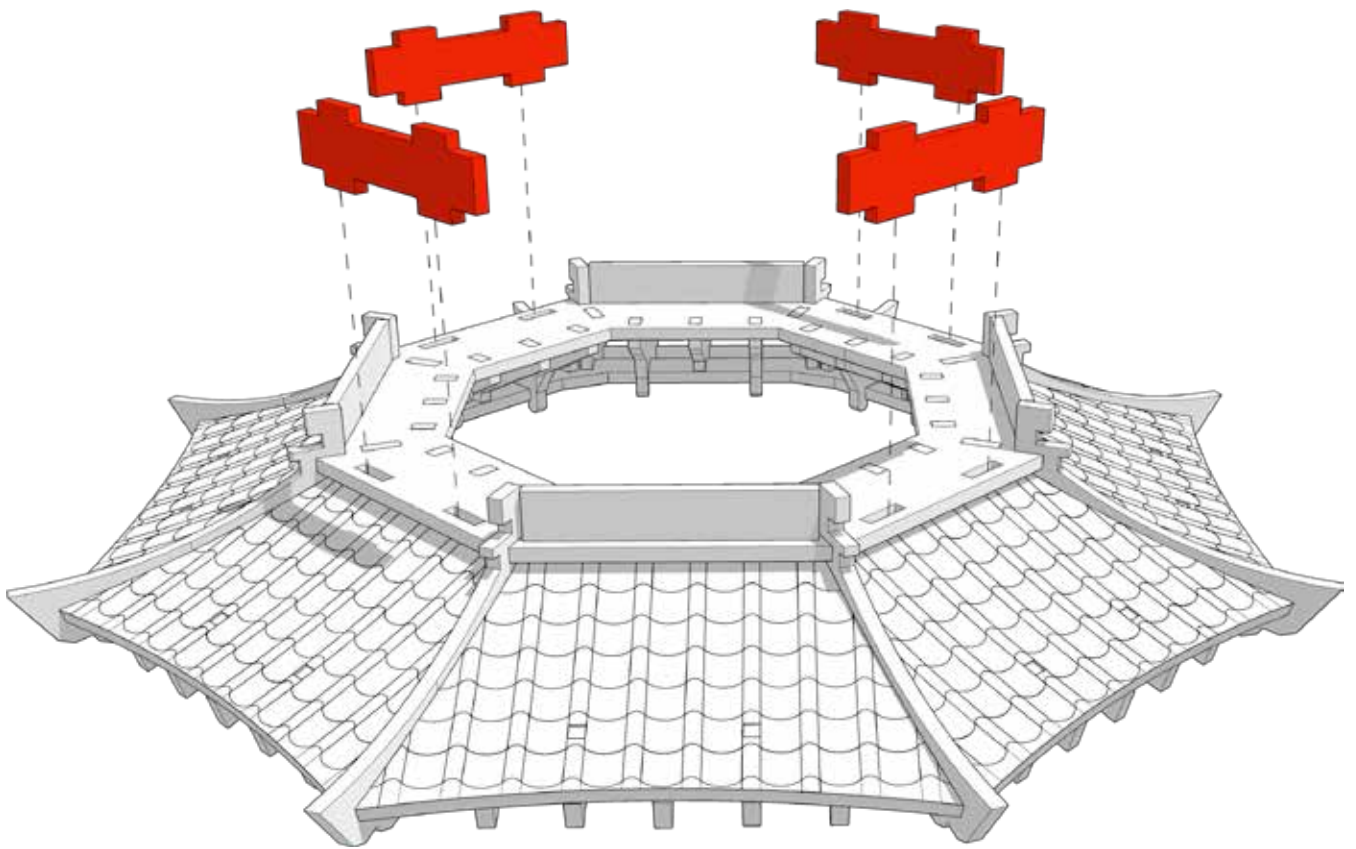



TABLETOP SCENICS

TTSCW-EES-110
Toshi
Hakkei-tō Pagoda

107

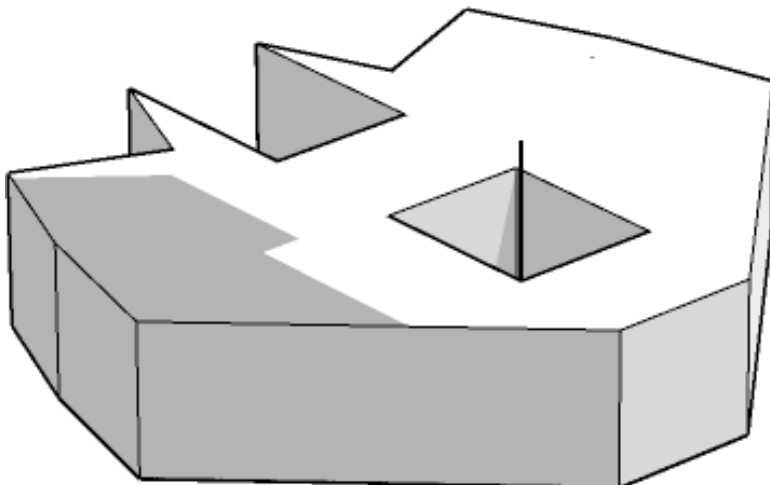
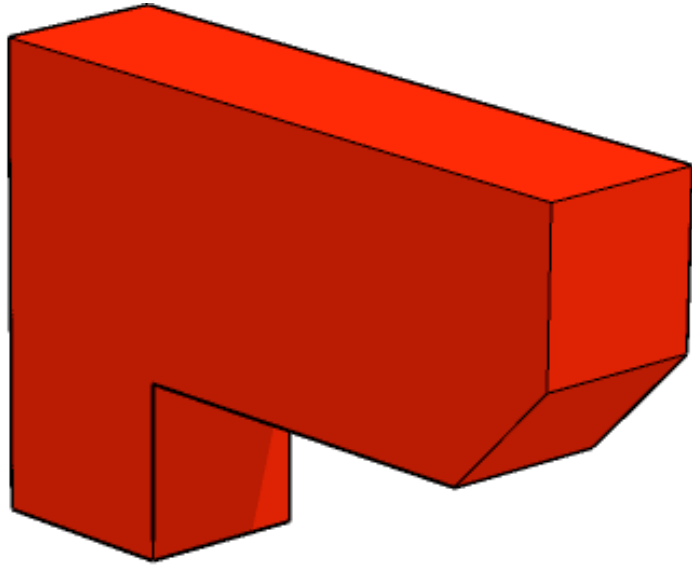



TABLETOP SCENICS

108

TTSCW-EES-110
Toshi
Hakkei-tō Pagoda

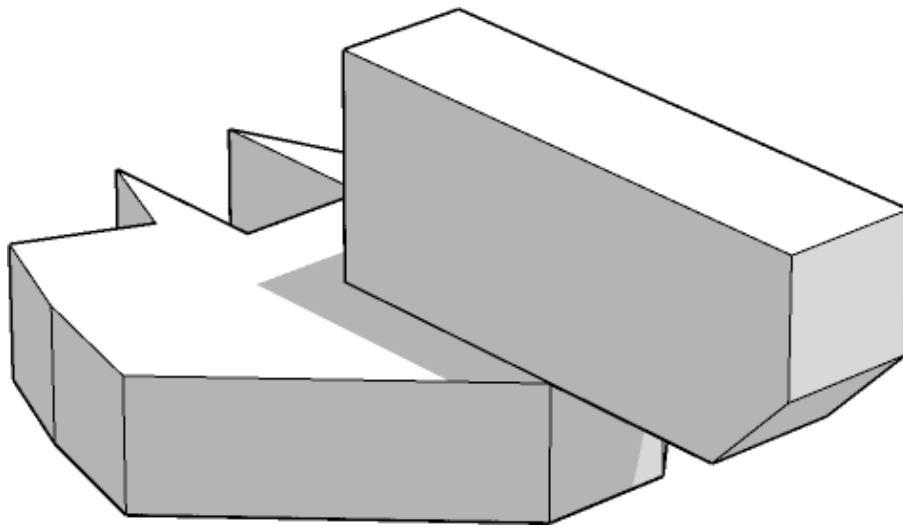



TABLETOP SCENICS

TTSCW-EES-110
Toshi
Hakkei-tō Pagoda

109

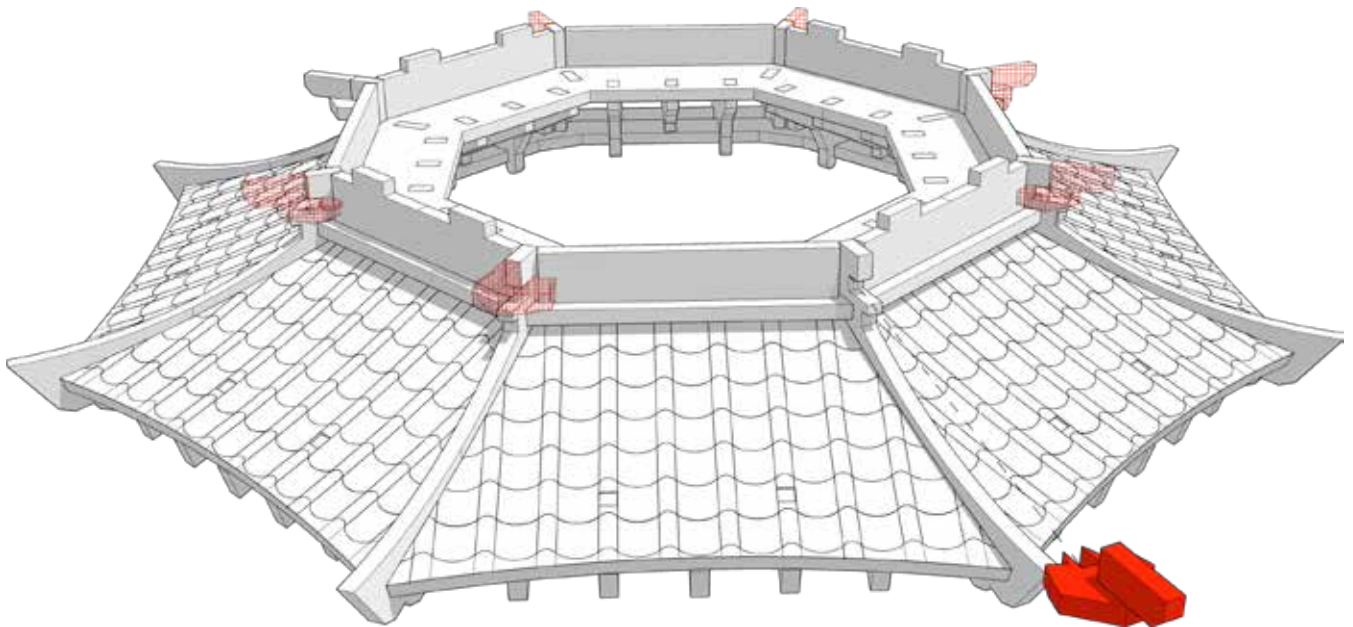

Repeat the step around the roof



TABLETOP SCENICS

110

TTSCW-EES-110
Toshi
Hakkei-tō Pagoda

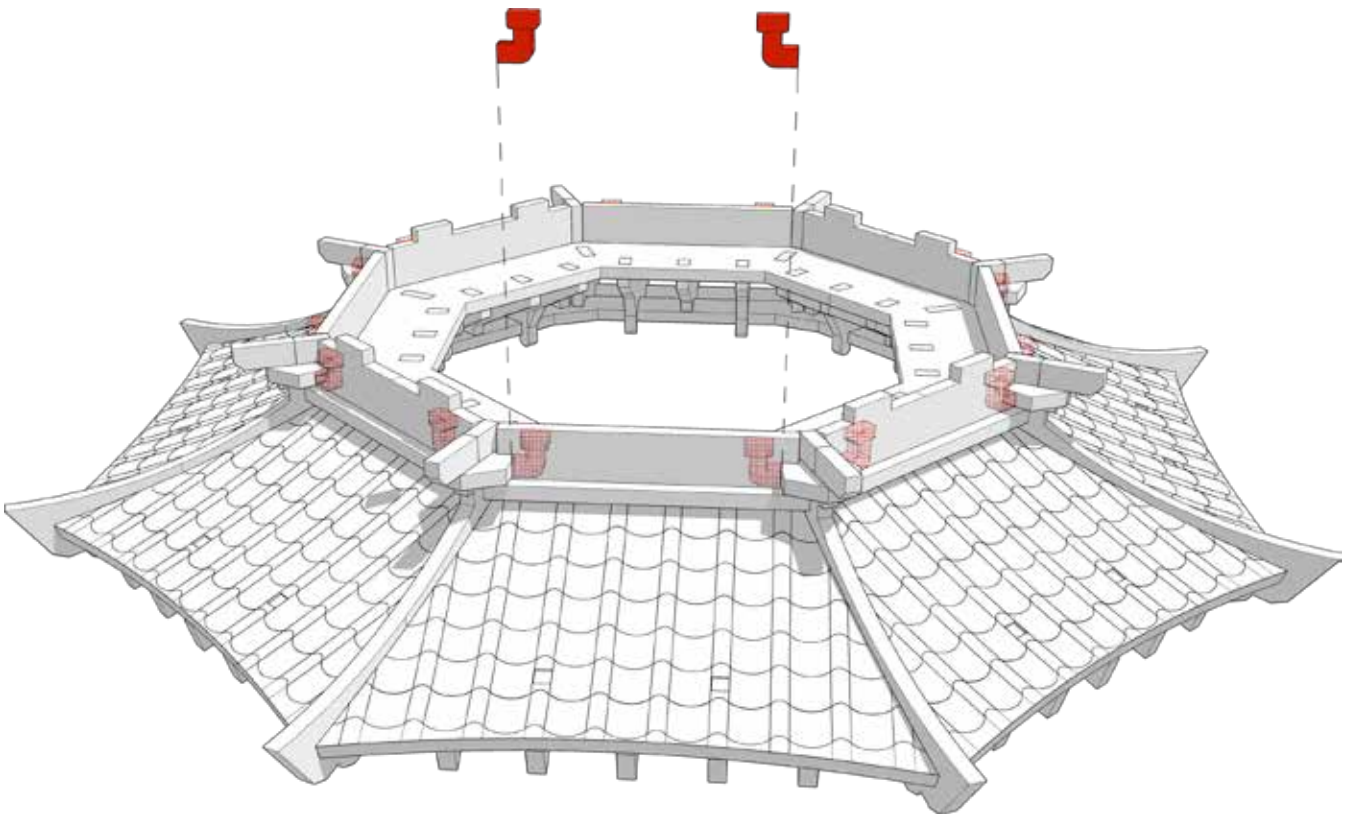

Repeat step around the roof



TABLETOP SCENICS

TTSCW-EES-110
Toshi
Hakkei-tō Pagoda

111

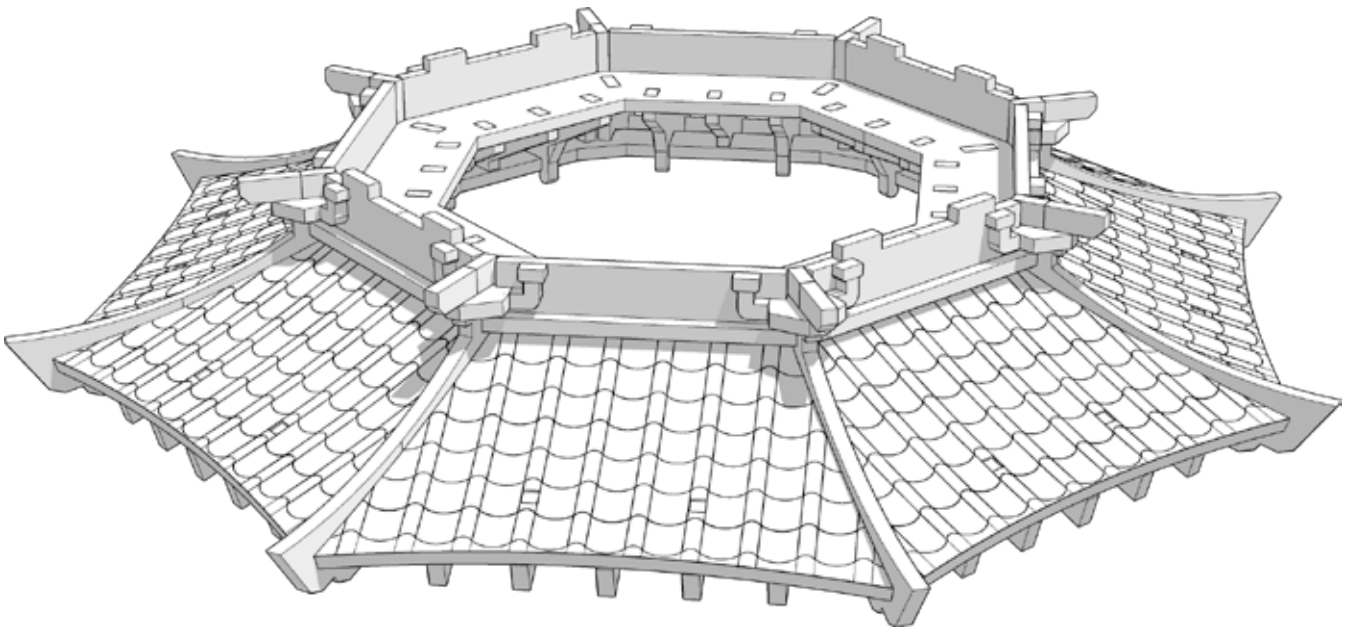



TABLETOP SCENICS

TTSCW-EES-110
Toshi
Hakkei-tō Pagoda

112

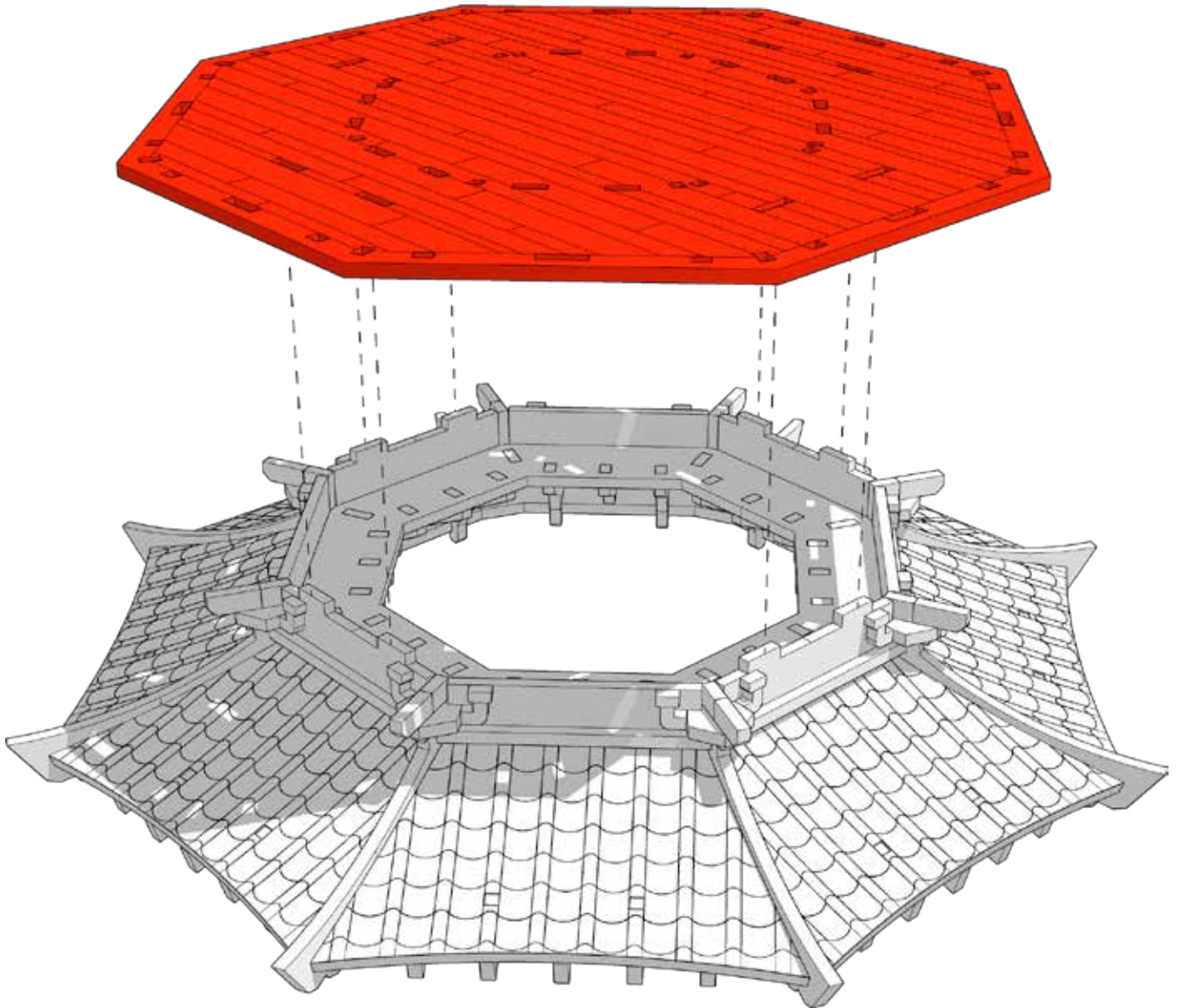



TABLETOP SCENICS

TTSCW-EES-110
Toshi
Hakkei-tō Pagoda

113

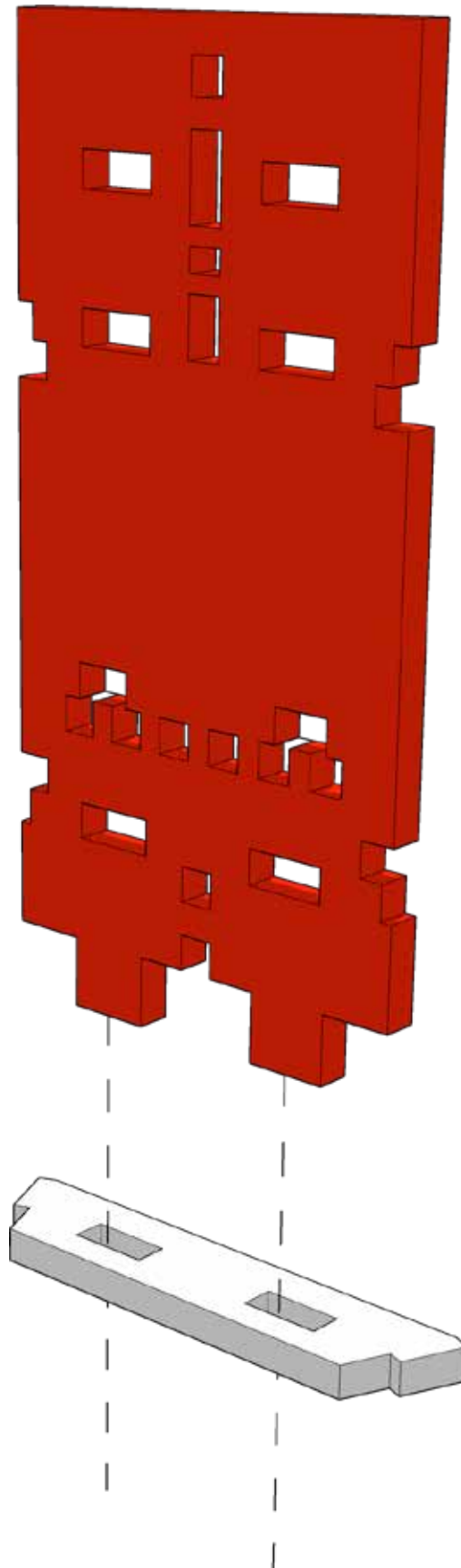



TABLETOP SCENICS

TTSCW-EES-110
Toshi
Hakkei-tō Pagoda

114

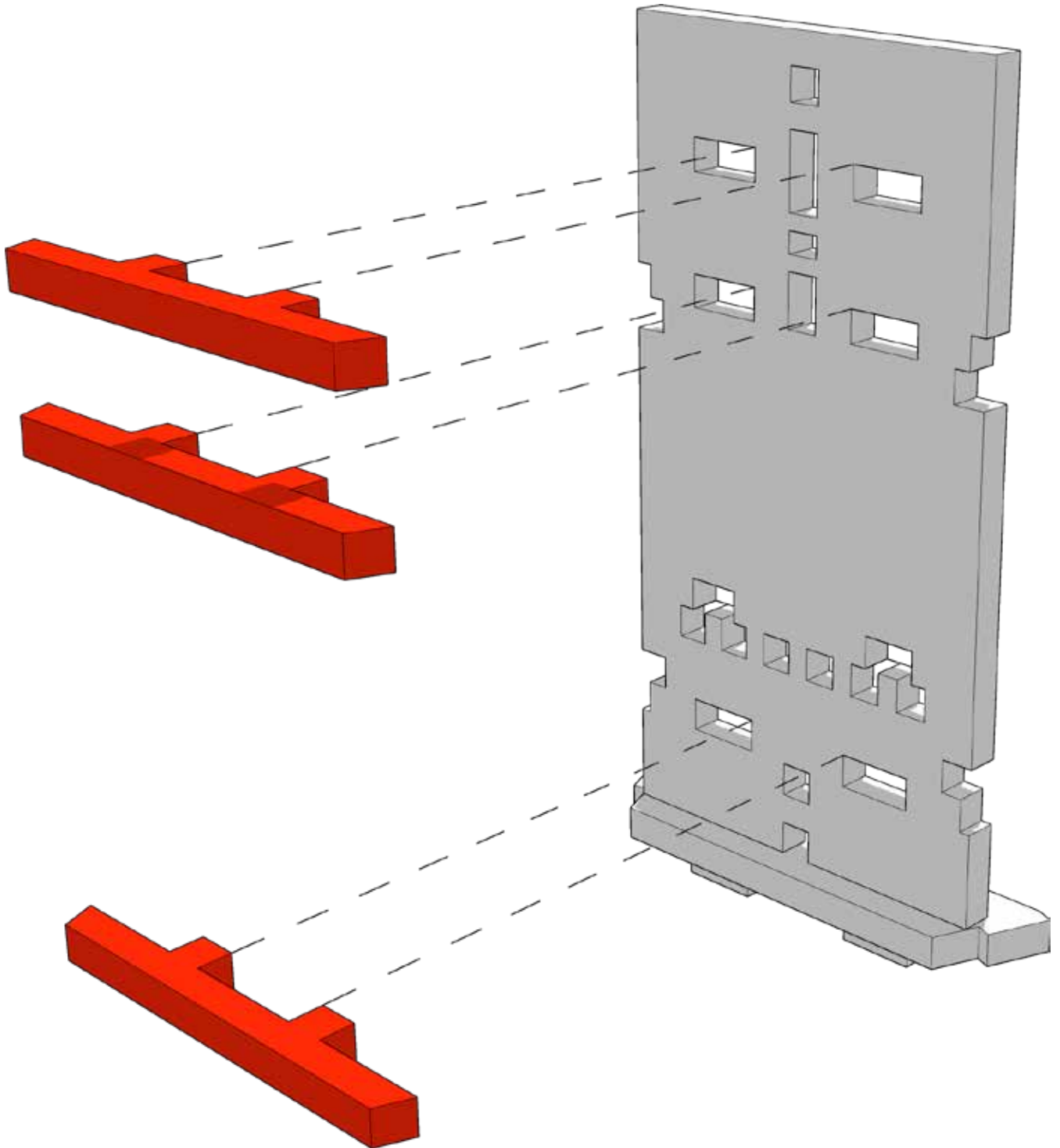



TABLETOP SCENICS

TTSCW-EES-110
Toshi
Hakkei-tō Pagoda

115

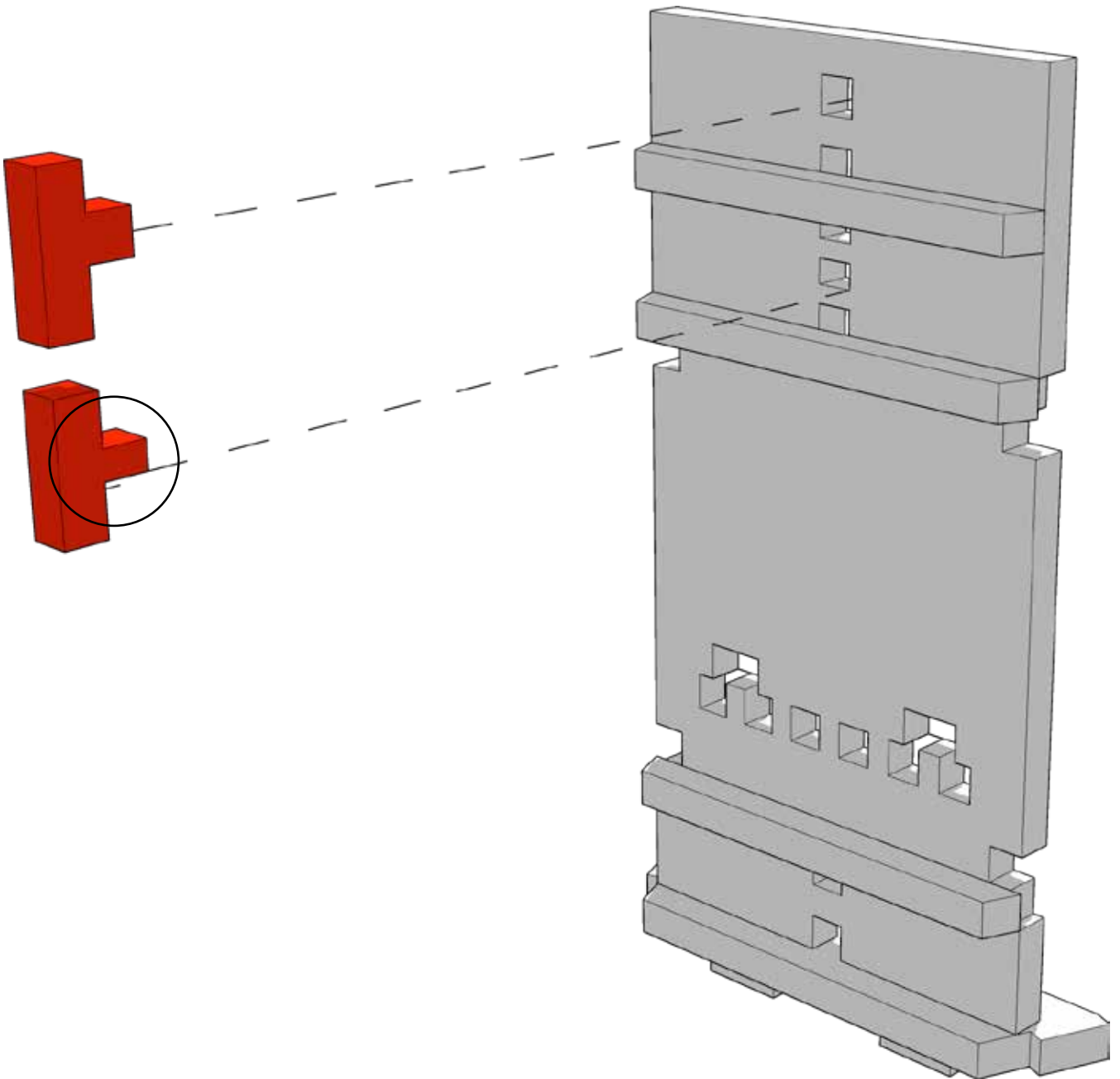

Circled part has a smaller tab than the one above and is labeled "B" on the sprues. The other is labeled "C"



TABLETOP SCENICS

TTSCW-EES-110
Toshi
Hakkei-tō Pagoda

116

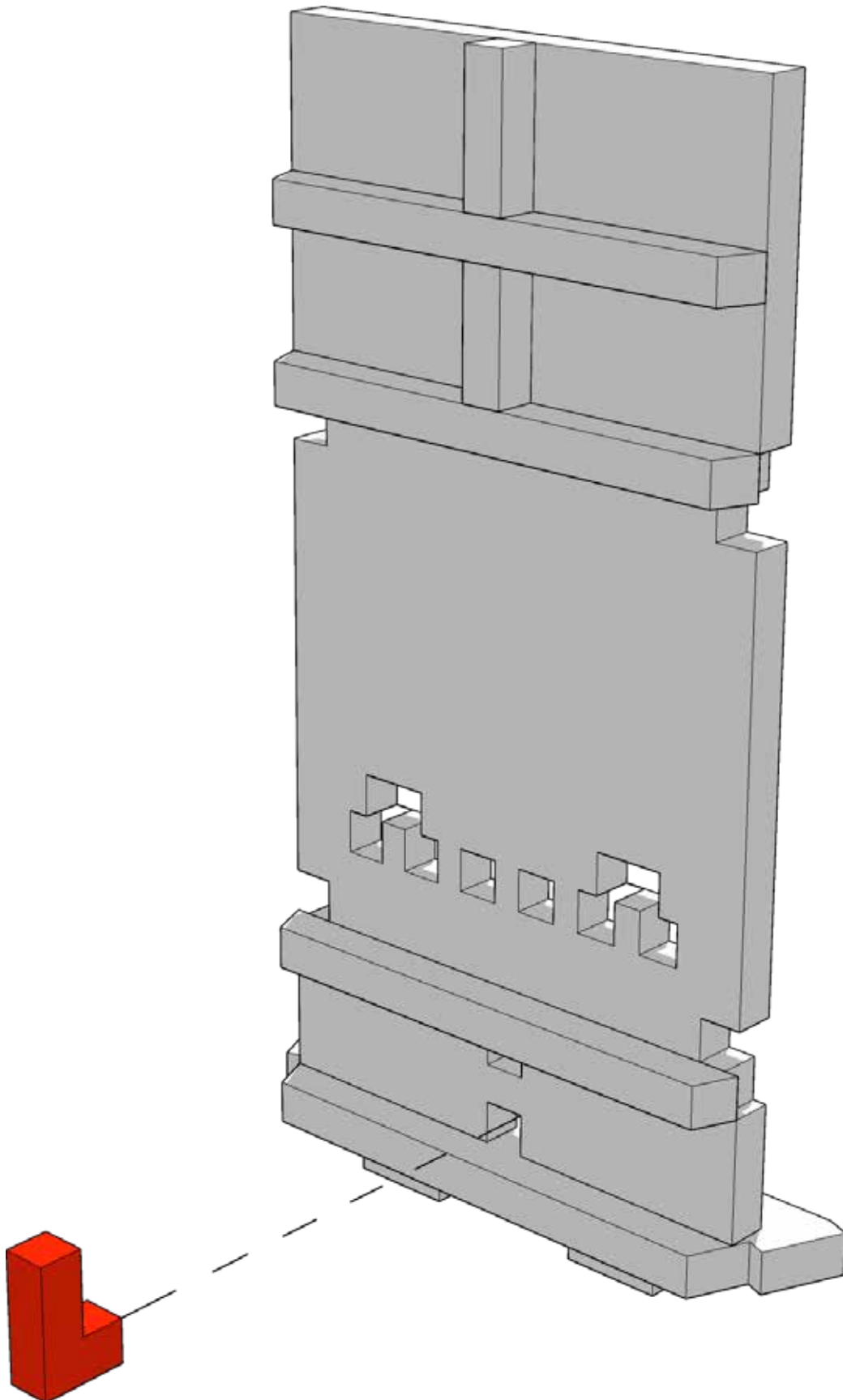

Highlighted part is labelled "A" on the sprues



TABLETOP SCENICS

TTSCW-EES-110
Toshi
Hakkei-tō Pagoda

117

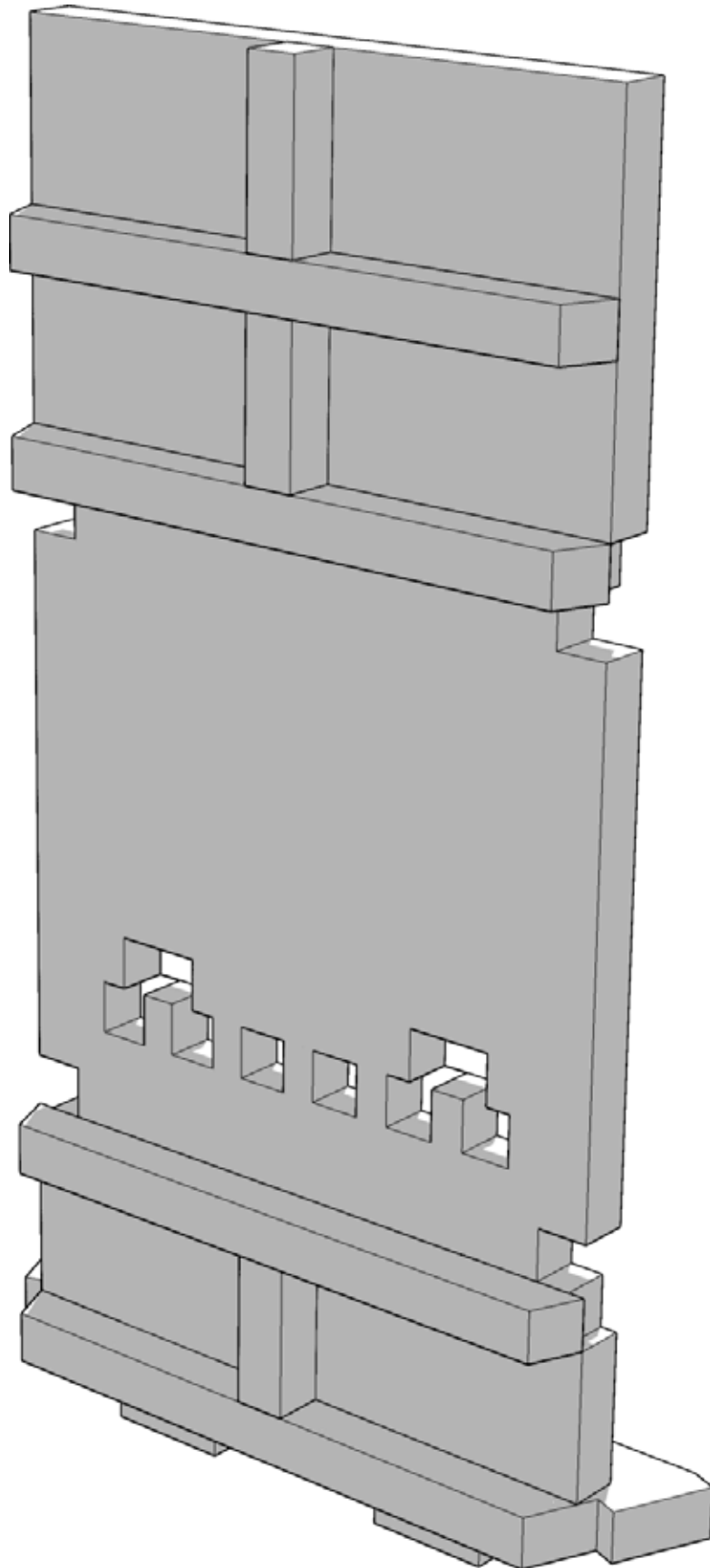



TABLETOP SCENICS

TTSCW-EES-110
Toshi
Hakkei-tō Pagoda

118

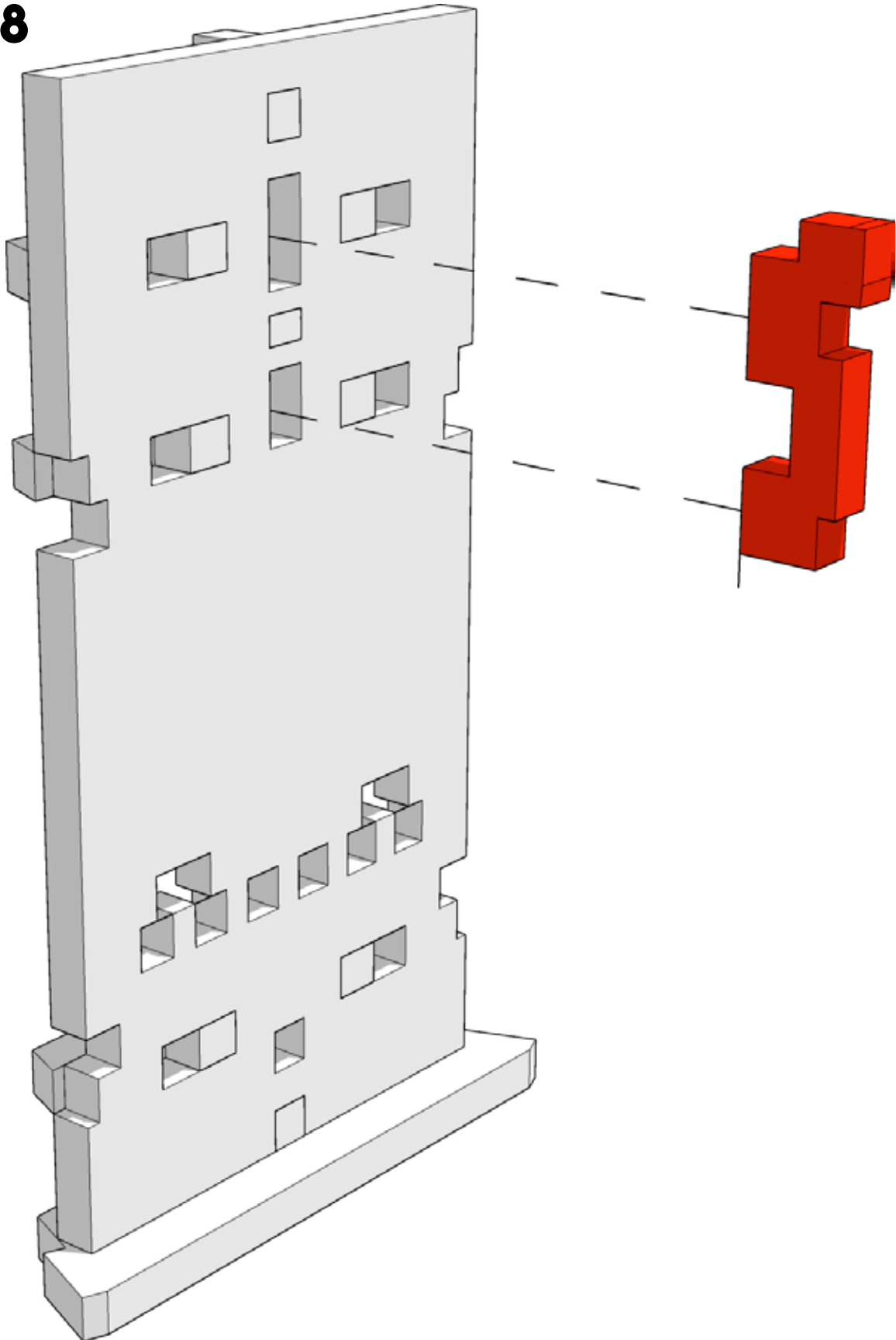



TABLETOP SCENICS

TTSCW-EES-110
Toshi
Hakkei-tō Pagoda

119

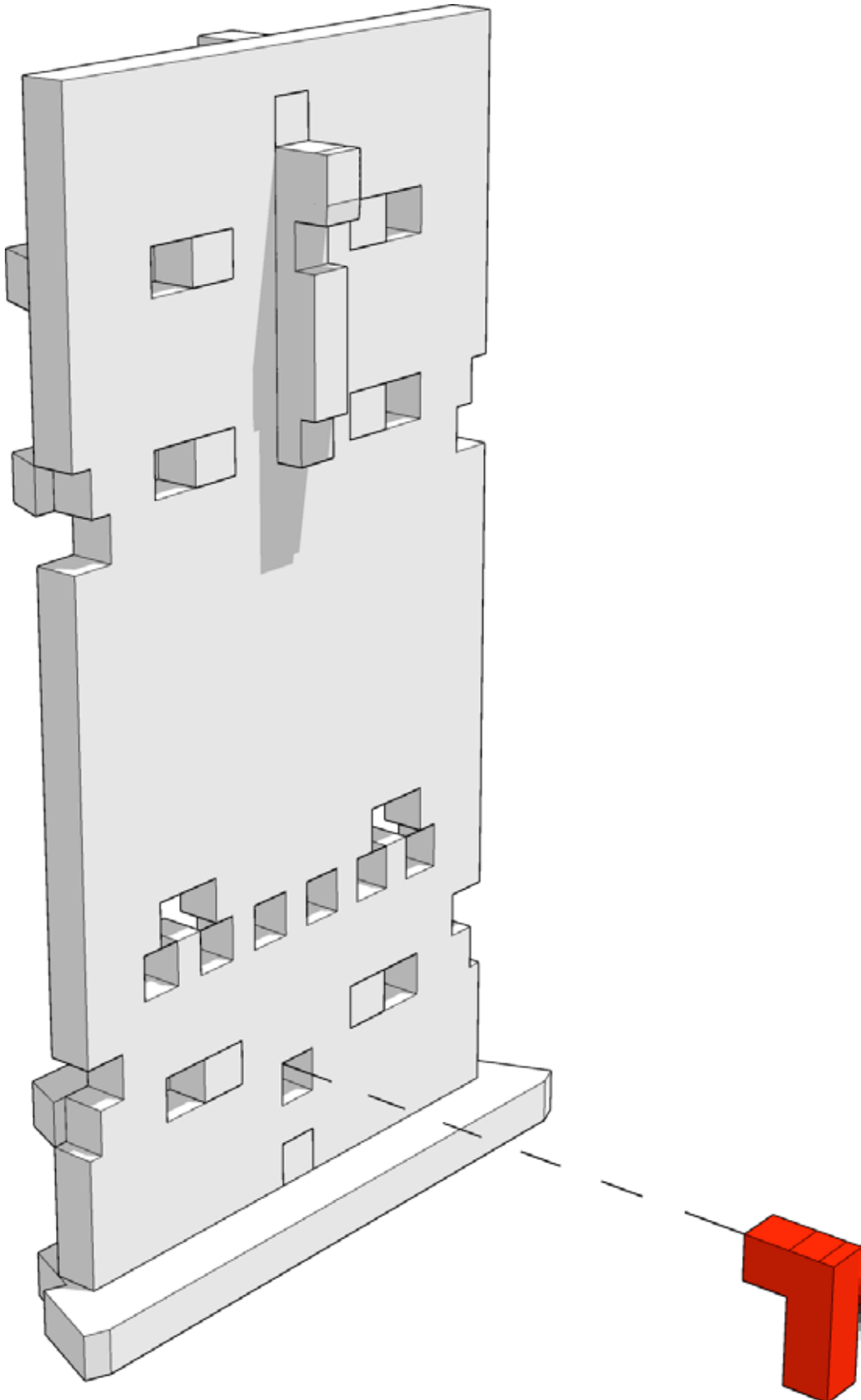



TABLETOP SCENICS

TTSCW-EES-110
Toshi
Hakkei-tō Pagoda

120

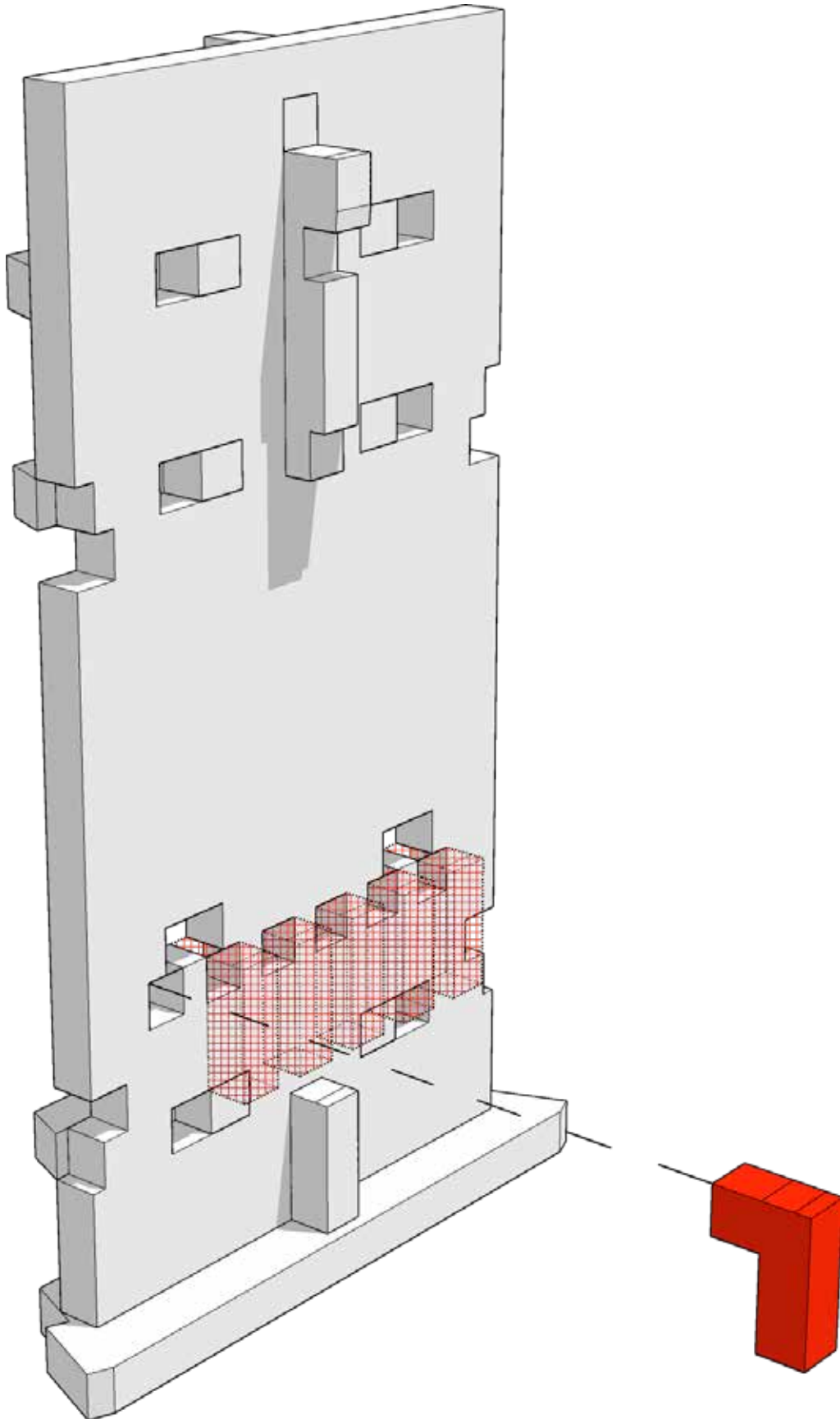



TABLETOP SCENICS

TTSCW-EES-110
Toshi
Hakkei-tō Pagoda

121

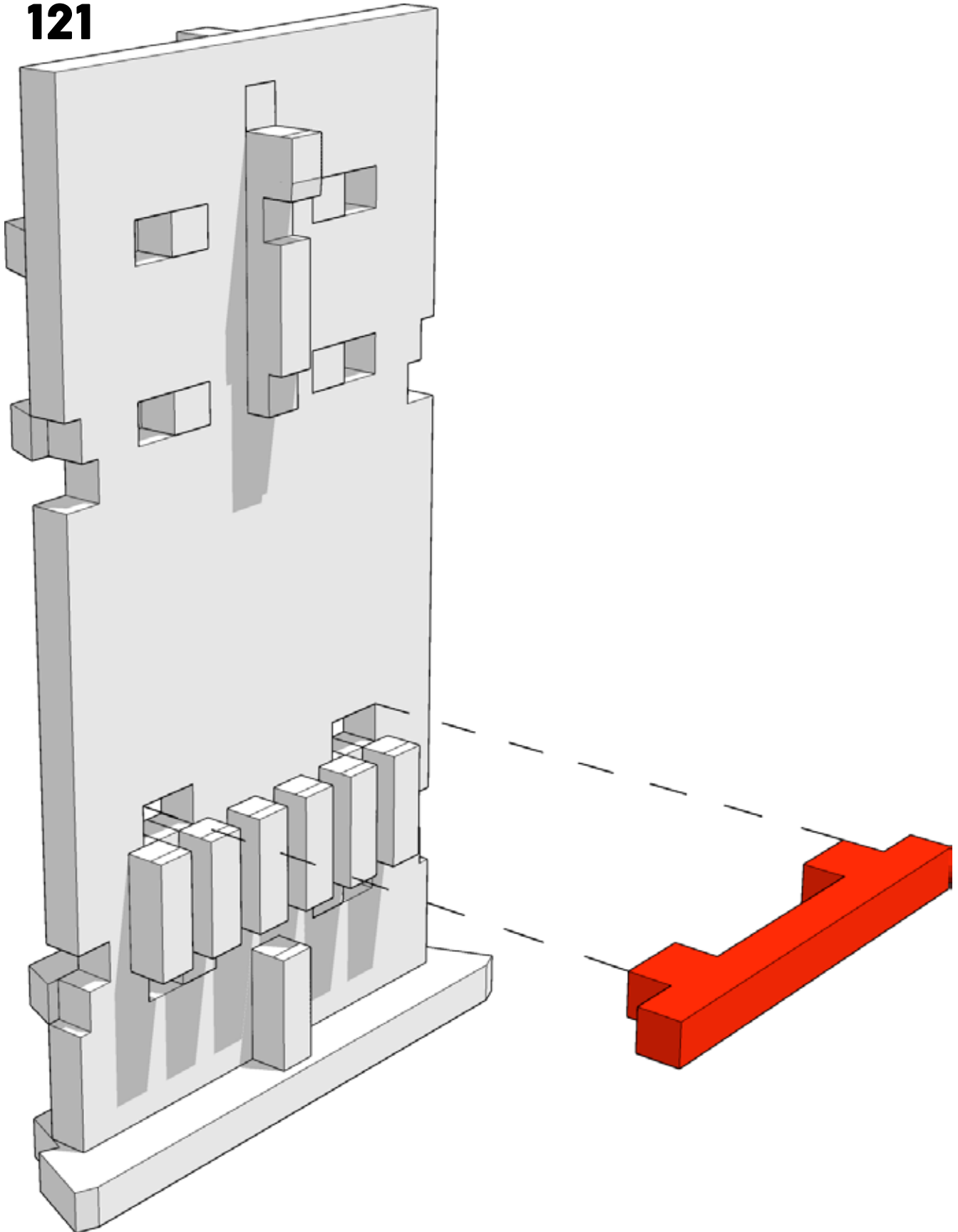



TABLETOP SCENICS

TTSCW-EES-110
Toshi
Hakkei-tō Pagoda

122

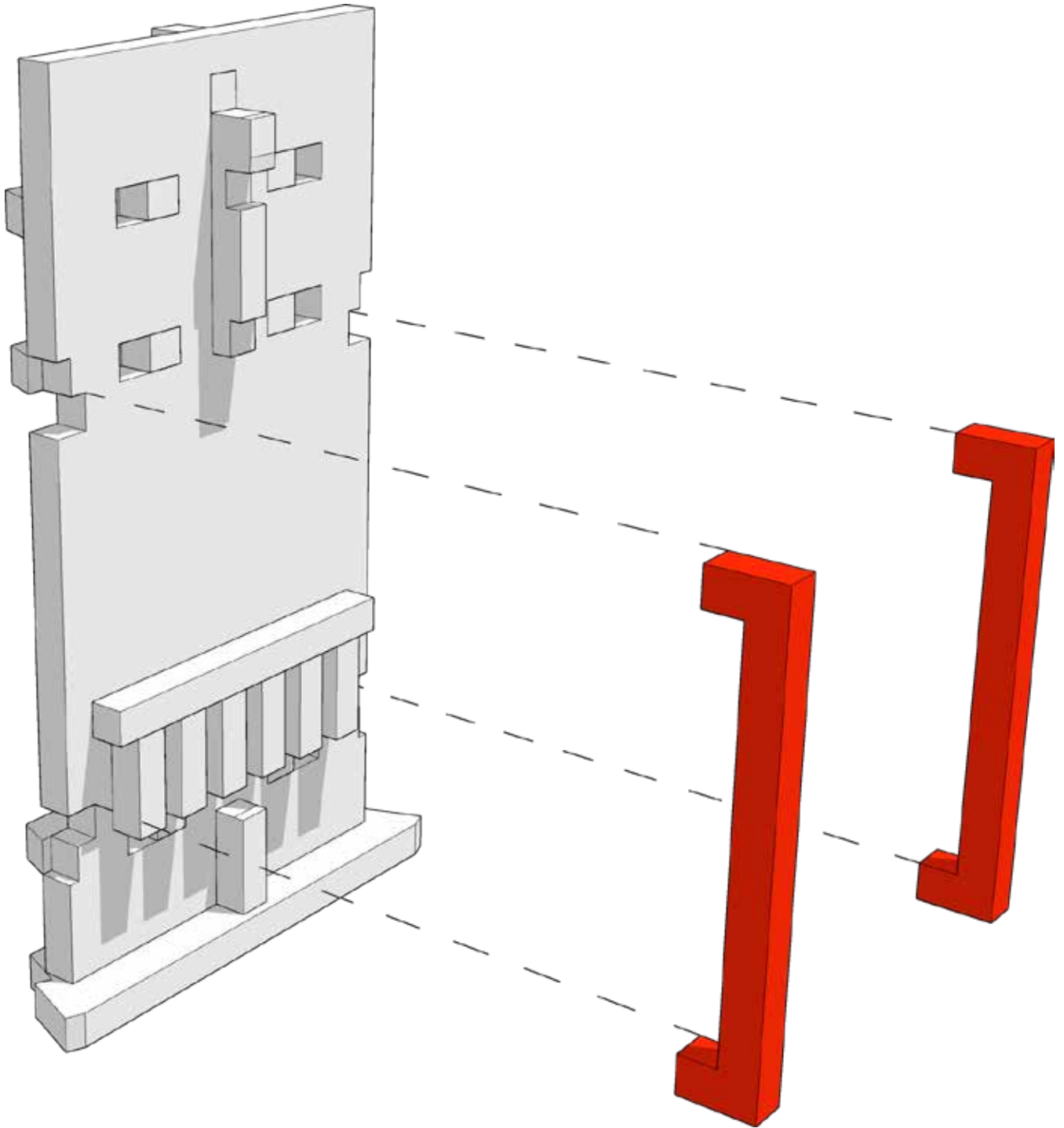



TABLETOP SCENICS

TTSCW-EES-110
Toshi
Hakkei-tō Pagoda

123

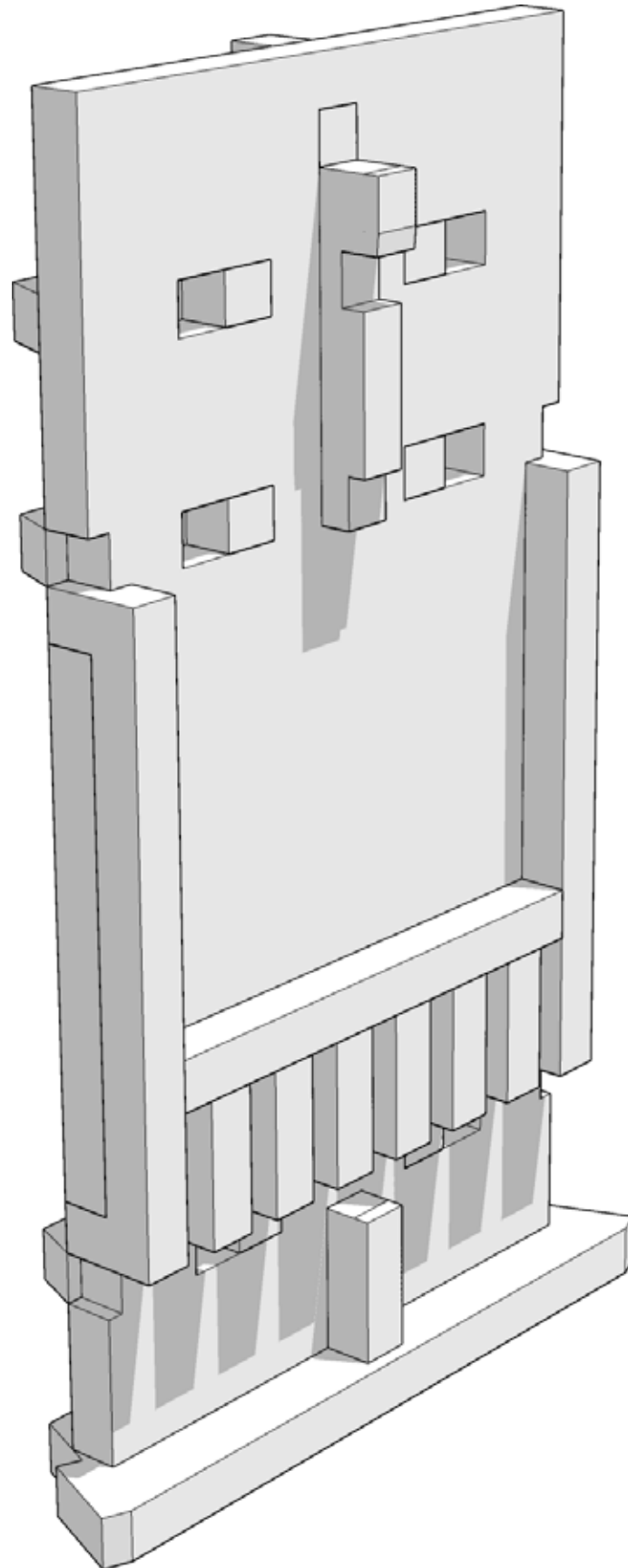



TABLETOP SCENICS

TTSCW-EES-110
Toshi
Hakkei-tō Pagoda

124

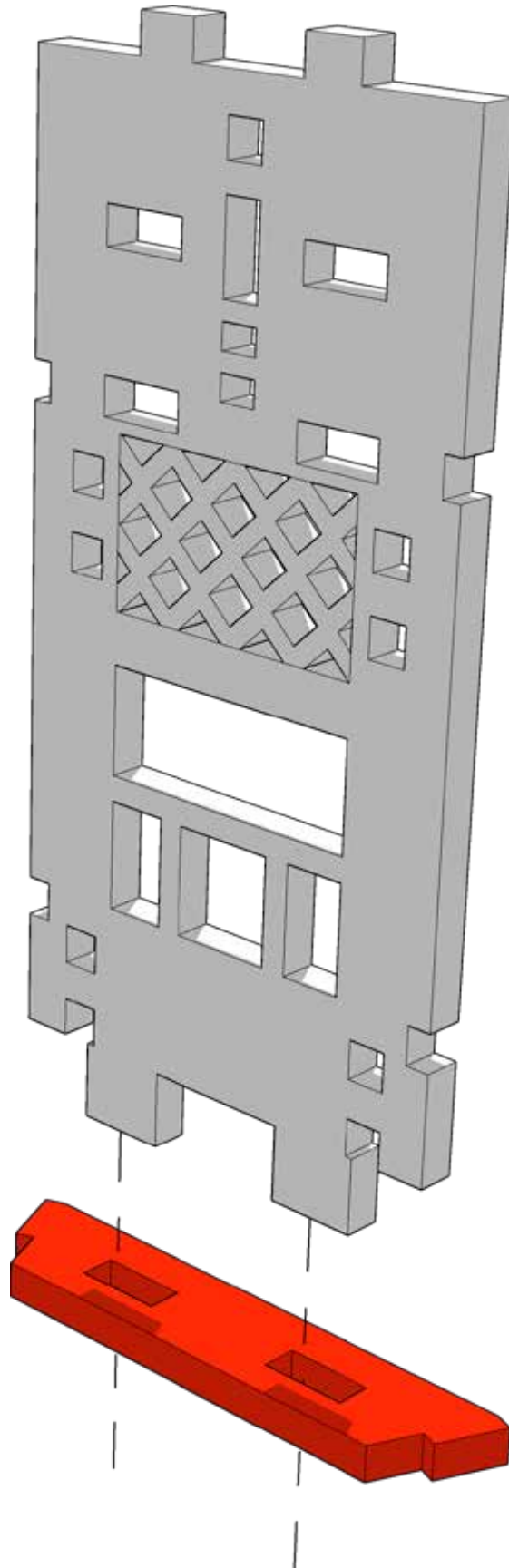



TABLETOP SCENICS

TTSCW-EES-110
Toshi
Hakkei-tō Pagoda

125

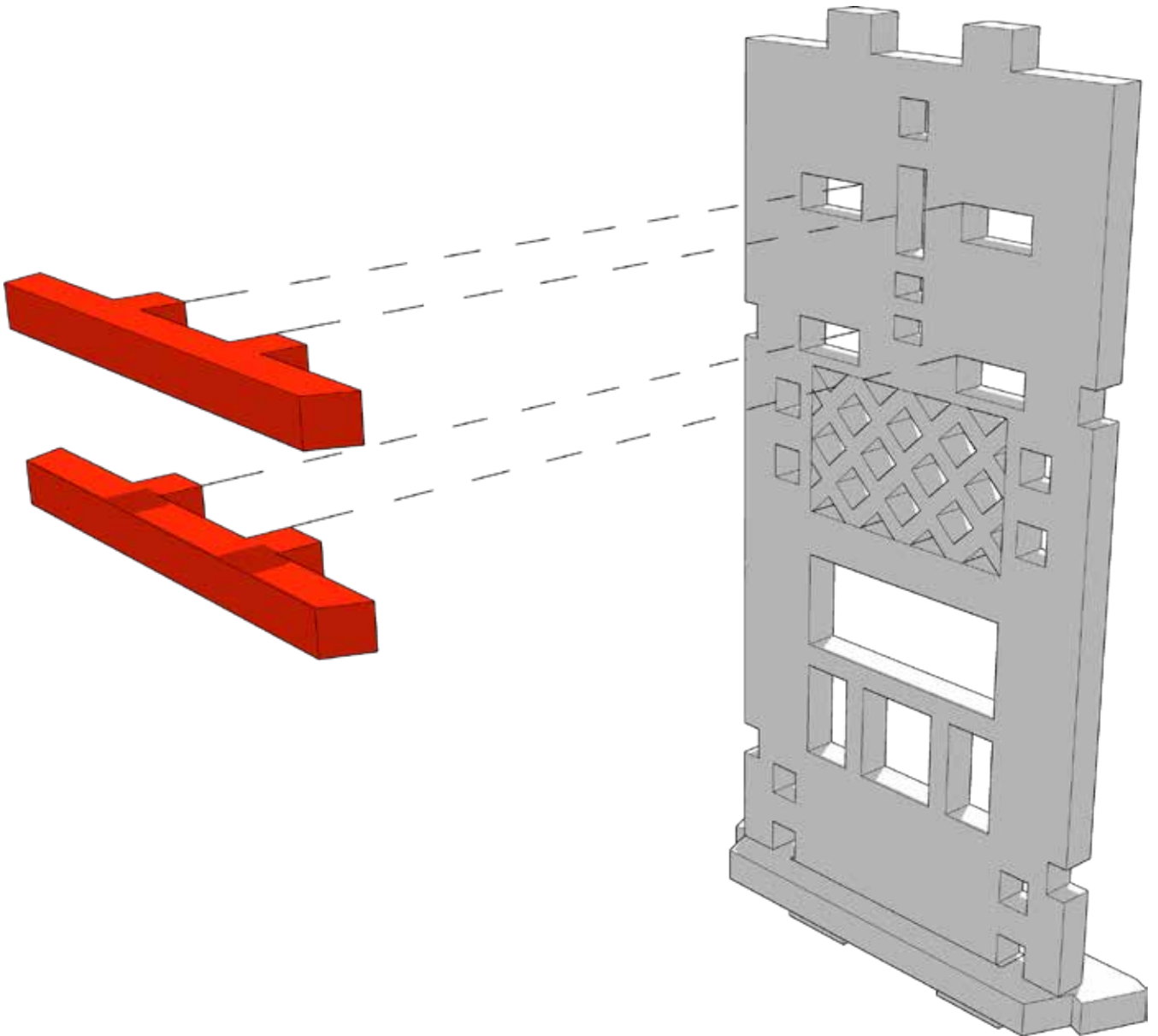



TABLETOP SCENICS

126

TTSCW-EES-110
Toshi
Hakkei-tō Pagoda

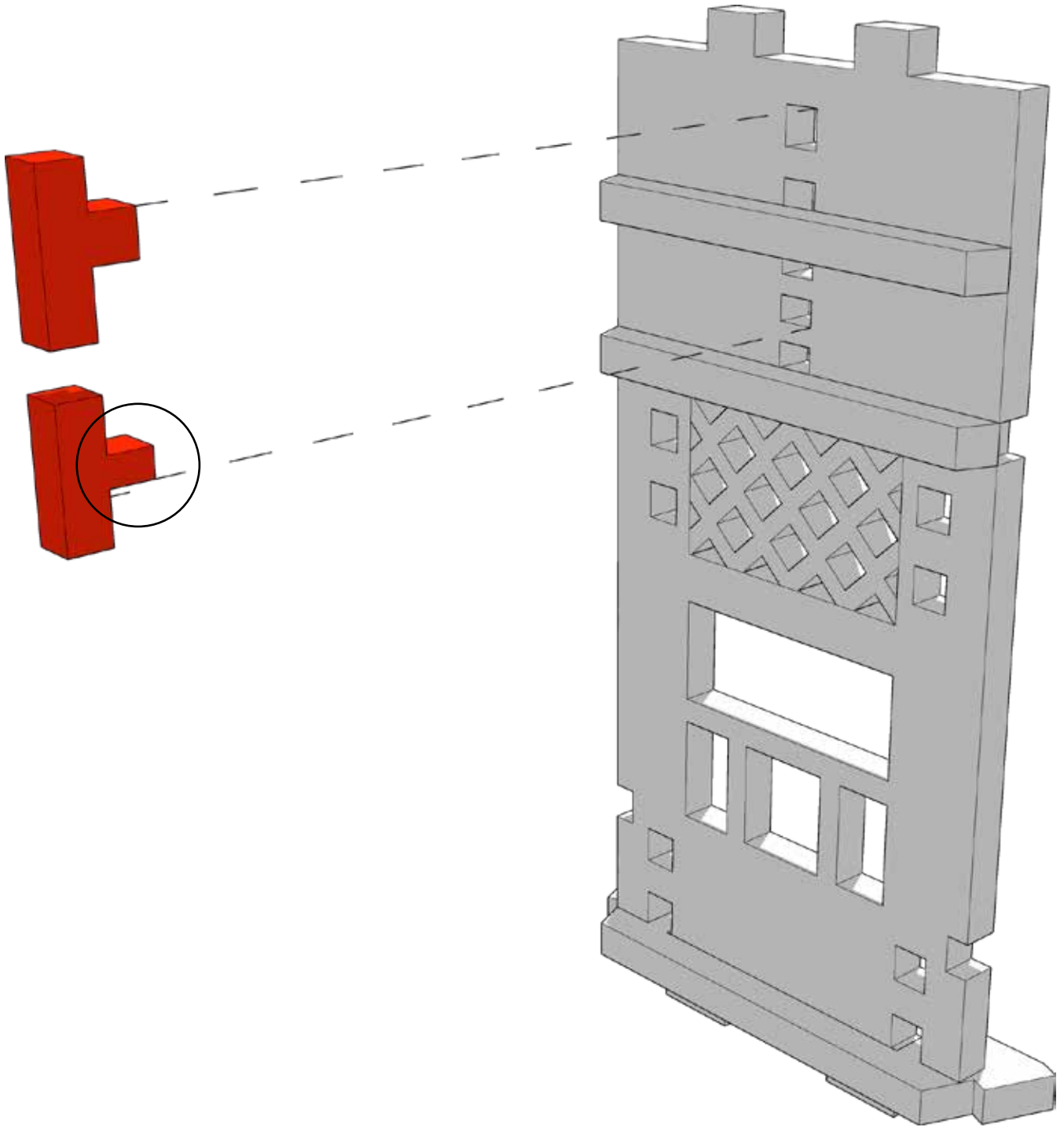

Circled part has a smaller tab than the one above and is labeled "B" on the sprues. The other is labeled "C"



TABLETOP
SCENICS

TTSCW-EES-110
Toshi
Hakkei-tō Pagoda

127

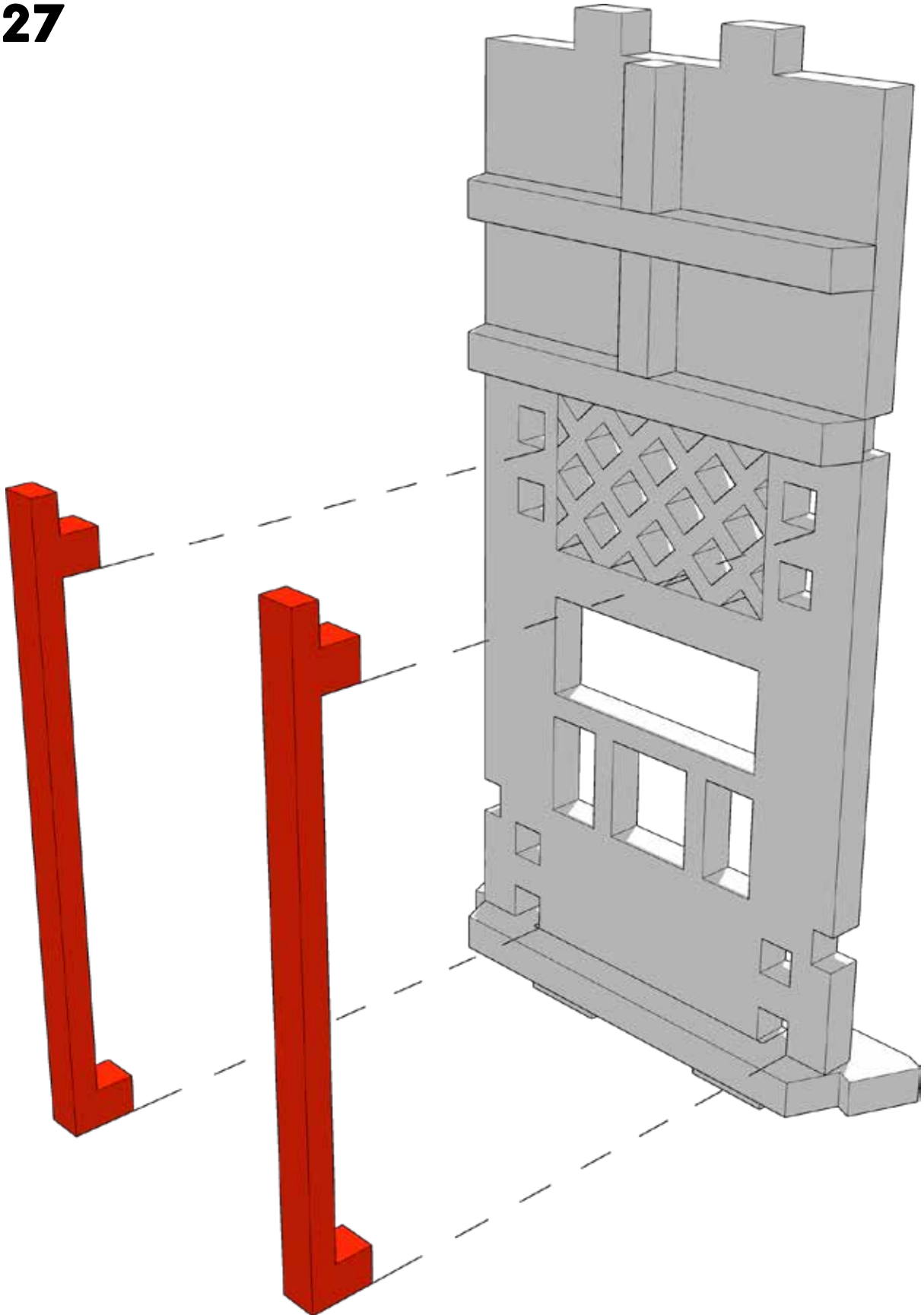



TABLETOP SCENICS

128

TTSCW-EES-110
Toshi
Hakkei-tō Pagoda

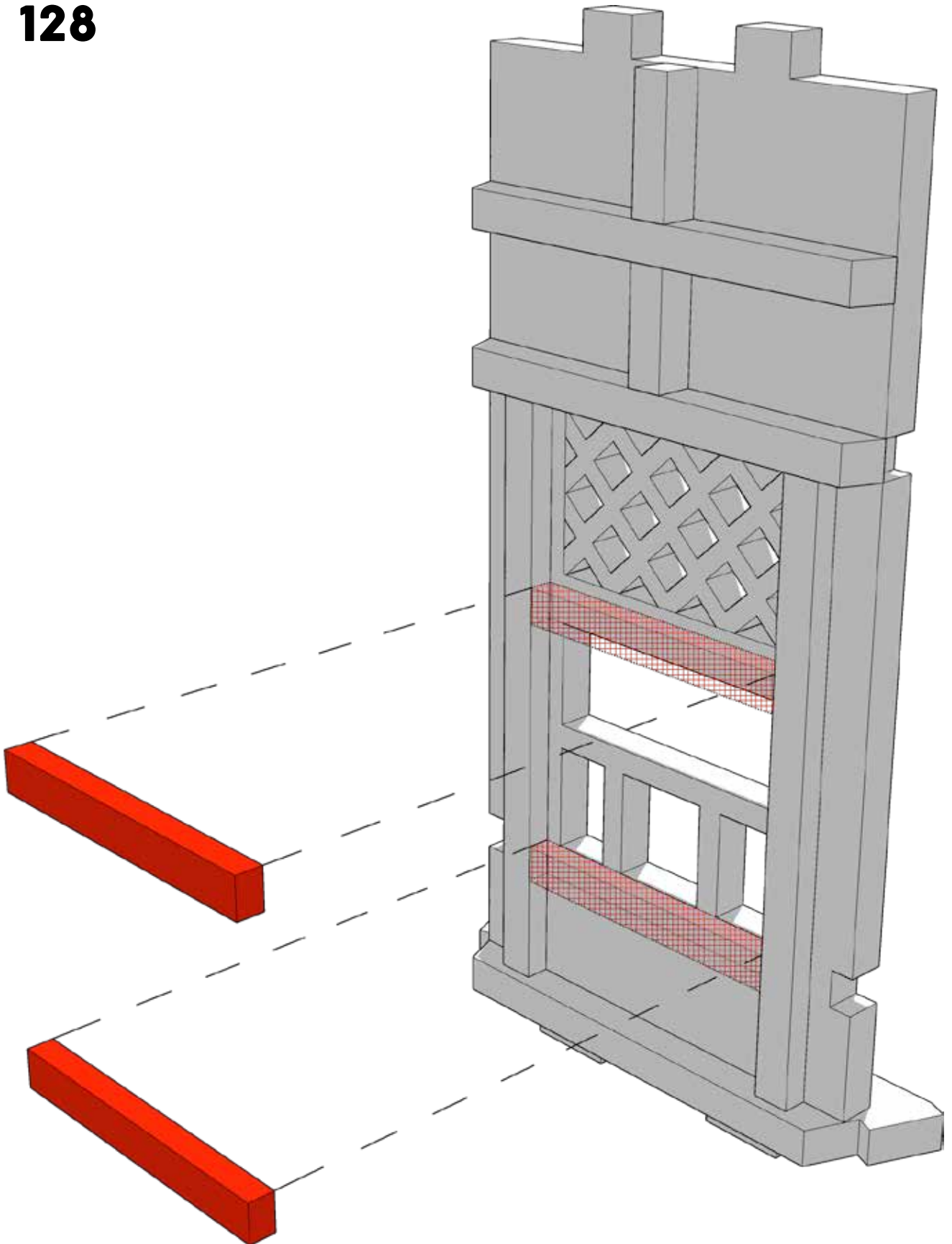



TABLETOP SCENICS

TTSCW-EES-110
Toshi
Hakkei-tō Pagoda

129

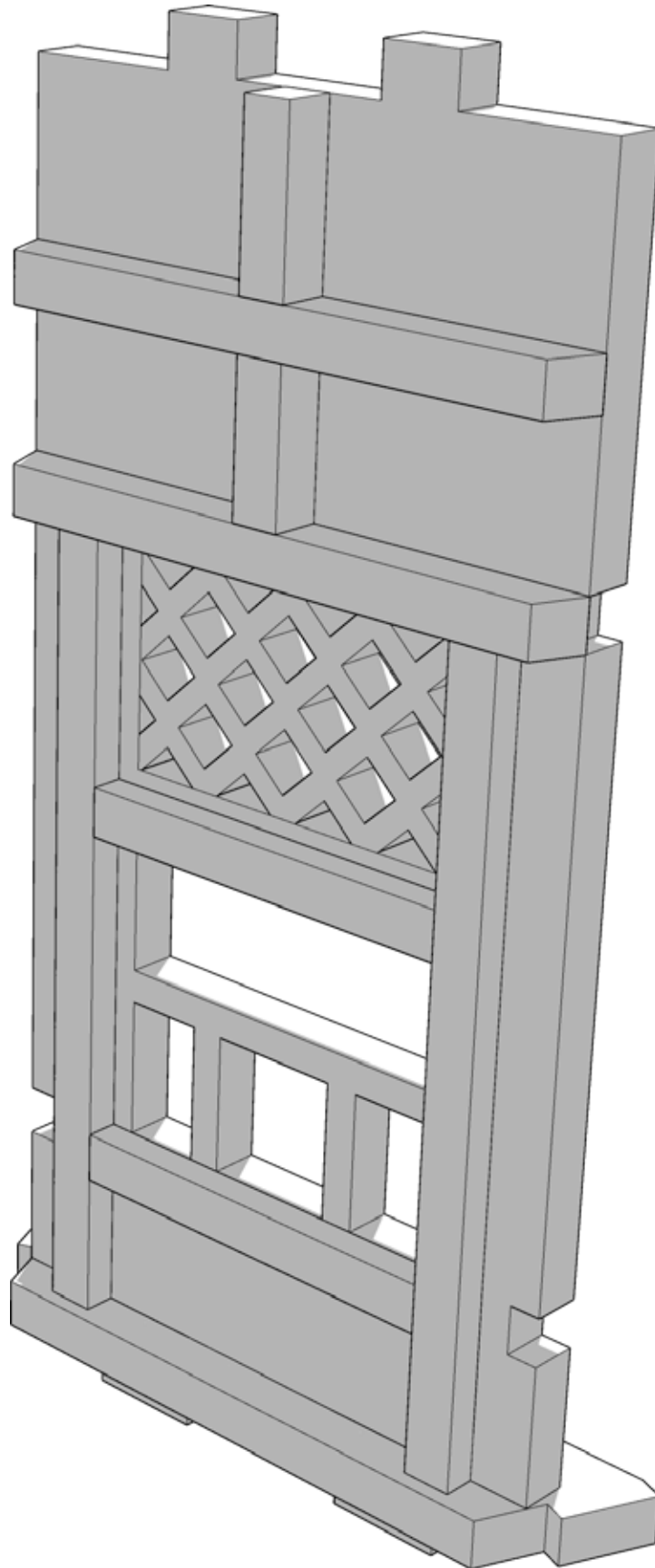



TABLETOP SCENICS

TTSCW-EES-110
Toshi
Hakkei-tō Pagoda

130

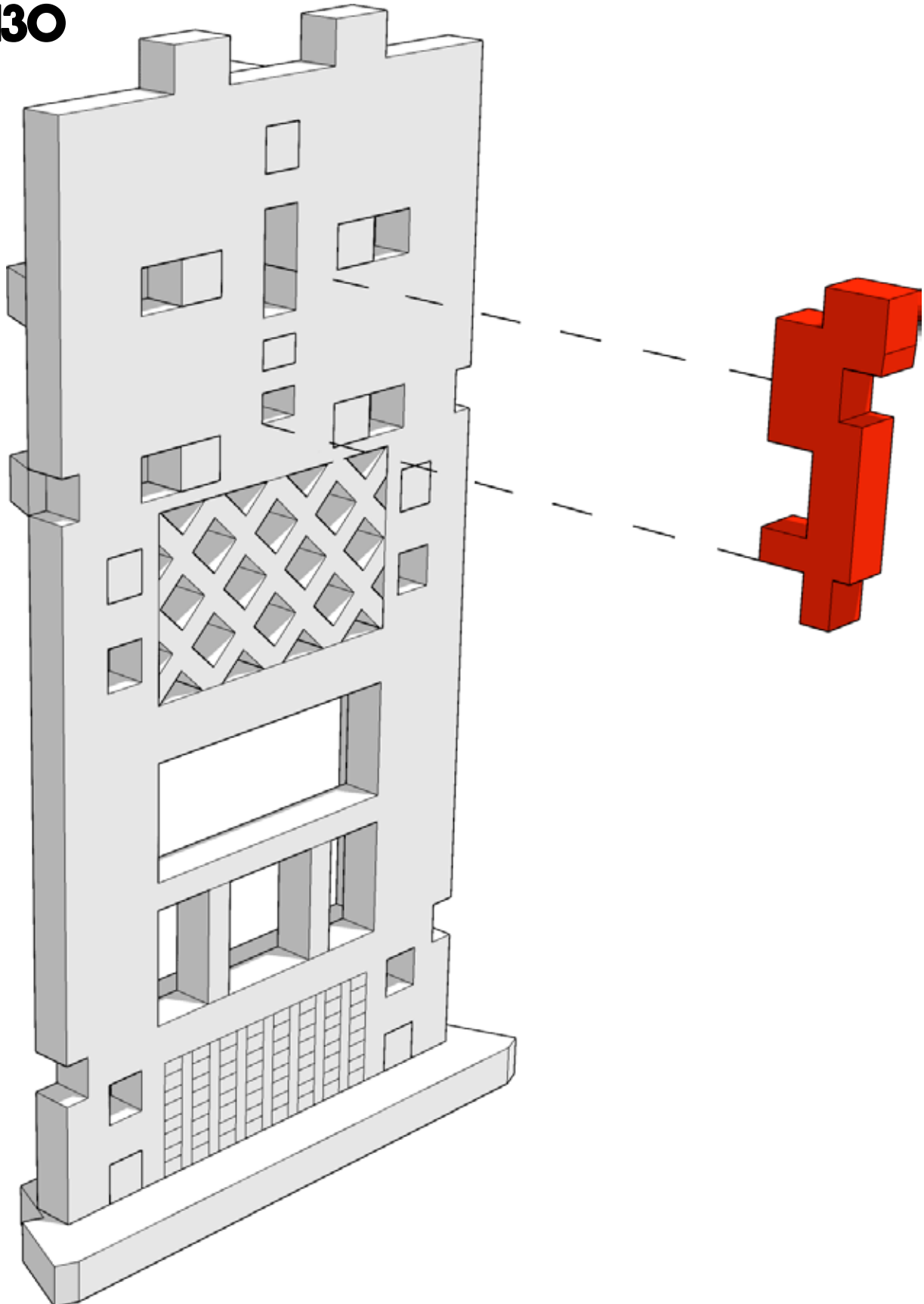



TABLETOP SCENICS

TTSCW-EES-110
Toshi
Hakkei-tō Pagoda

131

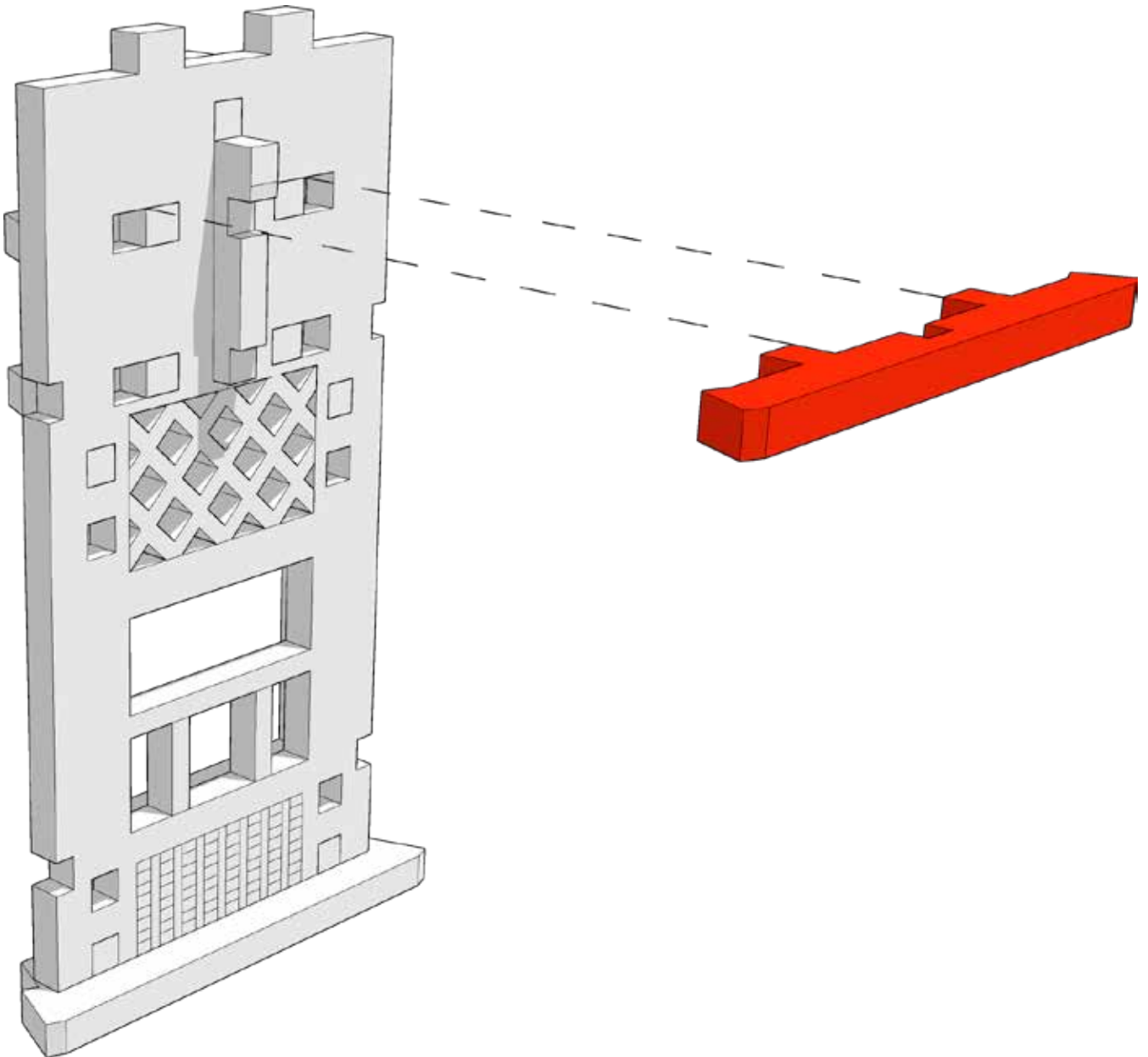



TABLETOP SCENICS

TTSCW-EES-110
Toshi
Hakkei-tō Pagoda

132

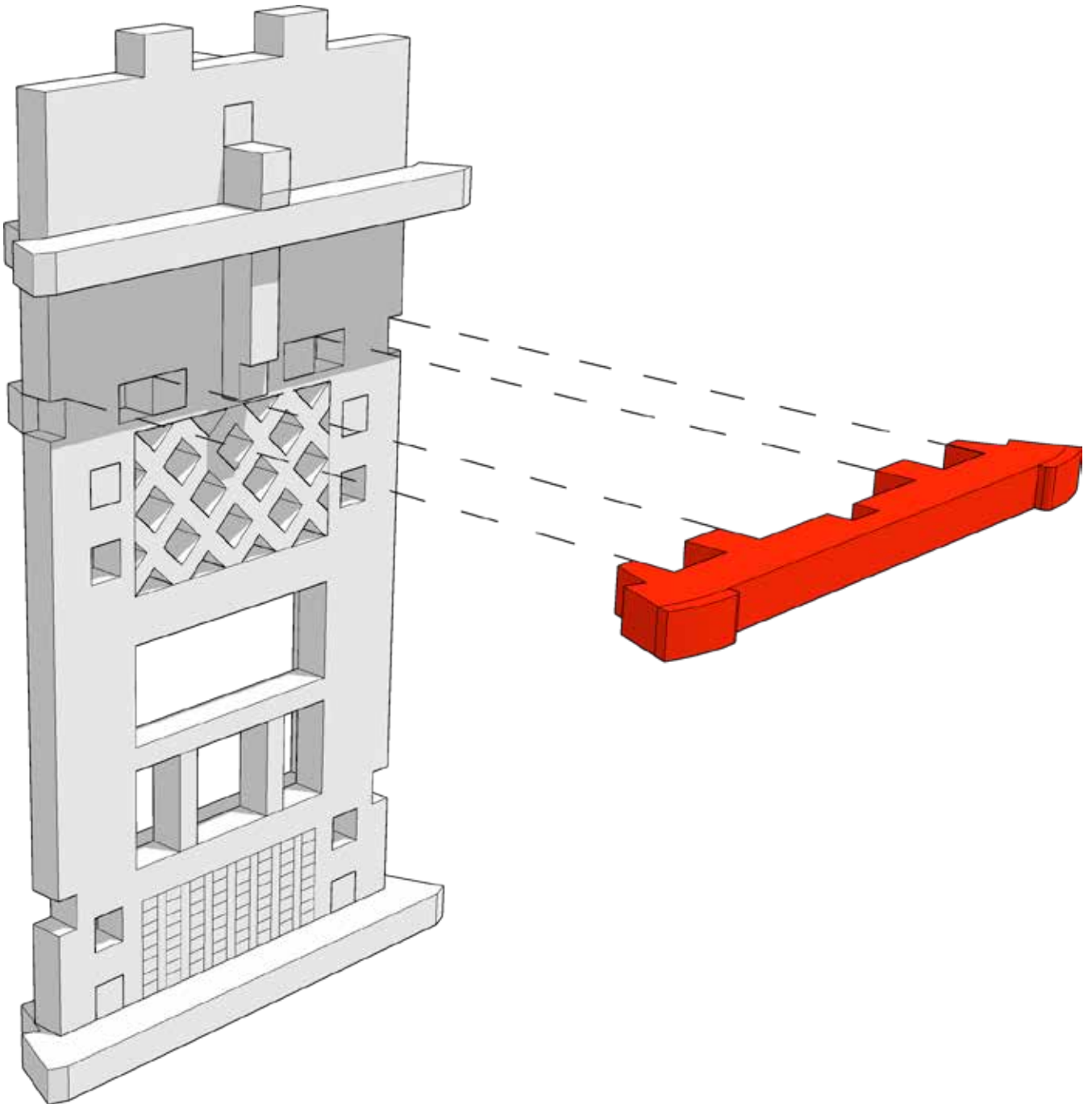



TABLETOP SCENICS

TTSCW-EES-110
Toshi
Hakkei-tō Pagoda

133

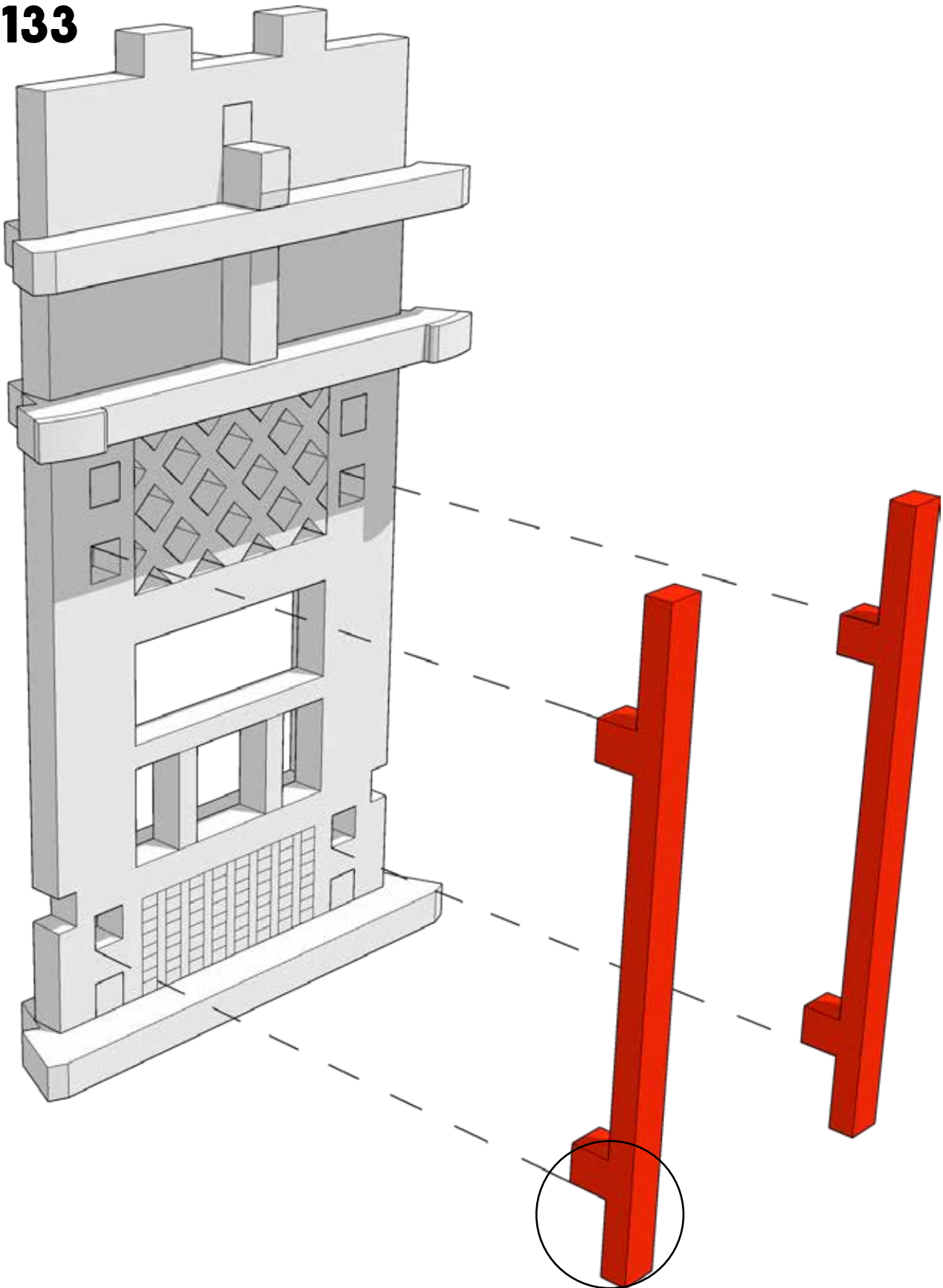

Highlighted parts are shorter at the bottom



TABLETOP SCENICS

TTSCW-EES-110
Toshi
Hakkei-tō Pagoda

134

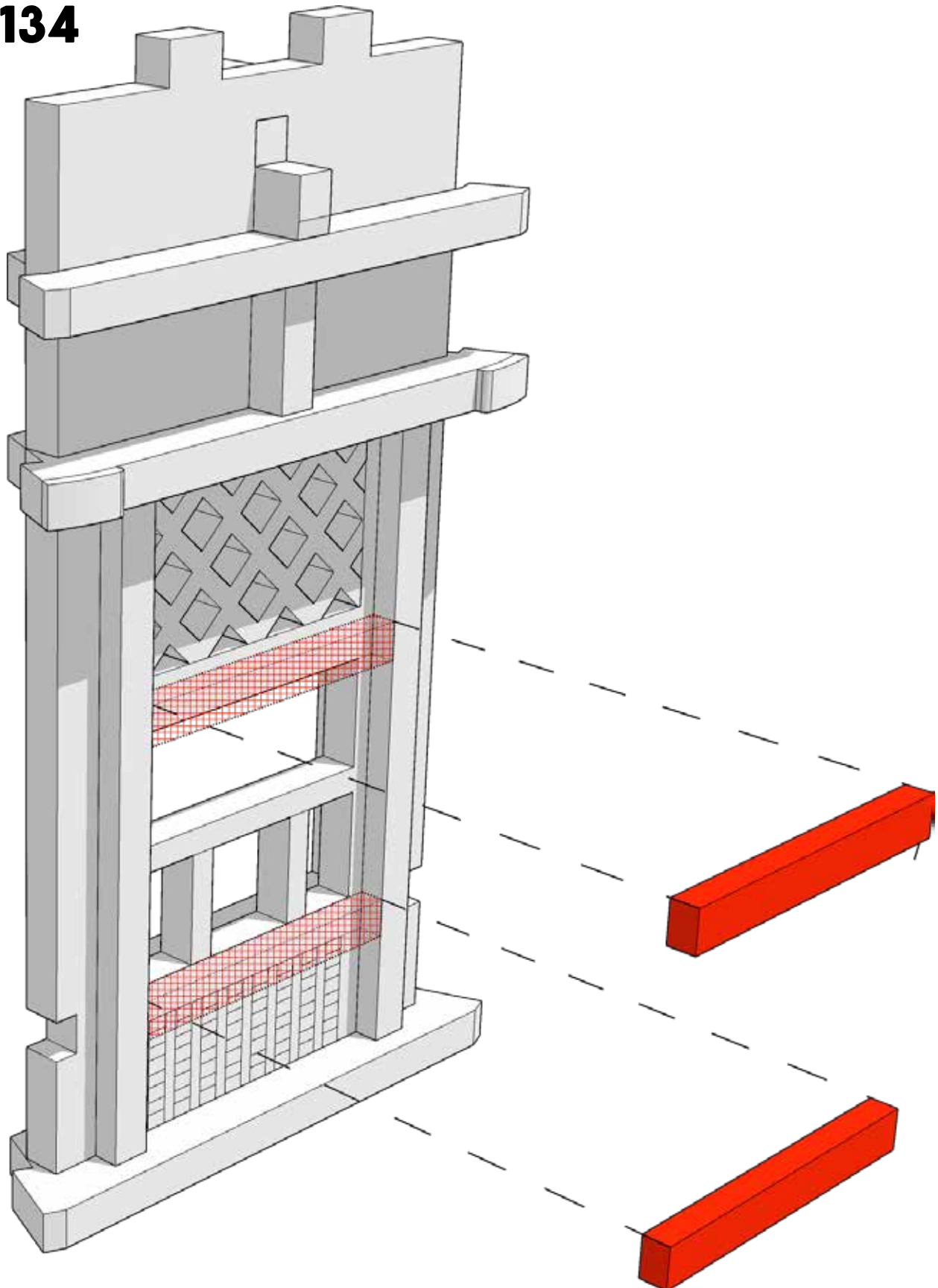



135

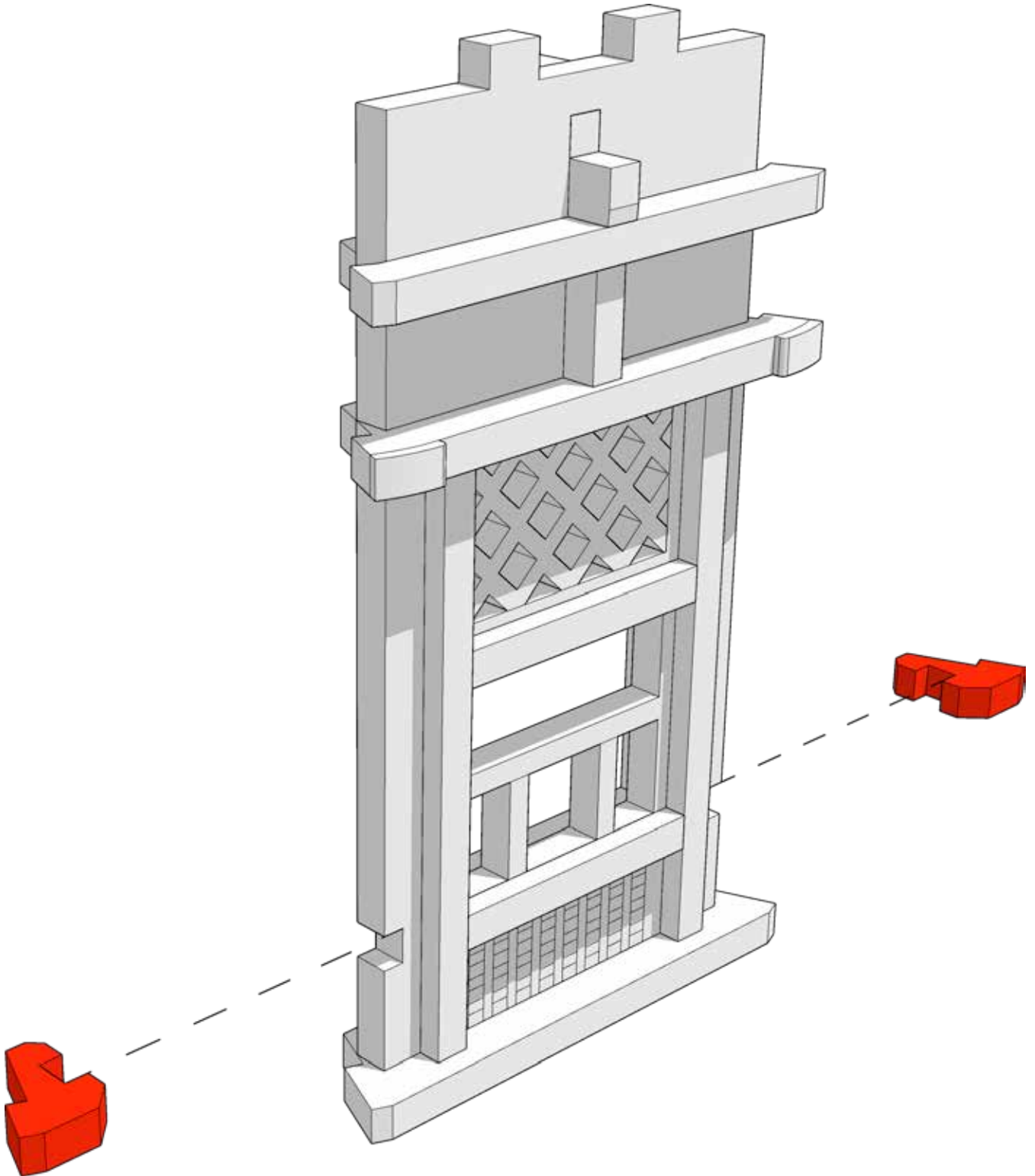

There are similar parts. The red highlighted one is required for the step shown on this page. Found on Sheet 16 of the sprues



TABLETOP SCENICS

136

TTSCW-EES-110
Toshi
Hakkei-tō Pagoda

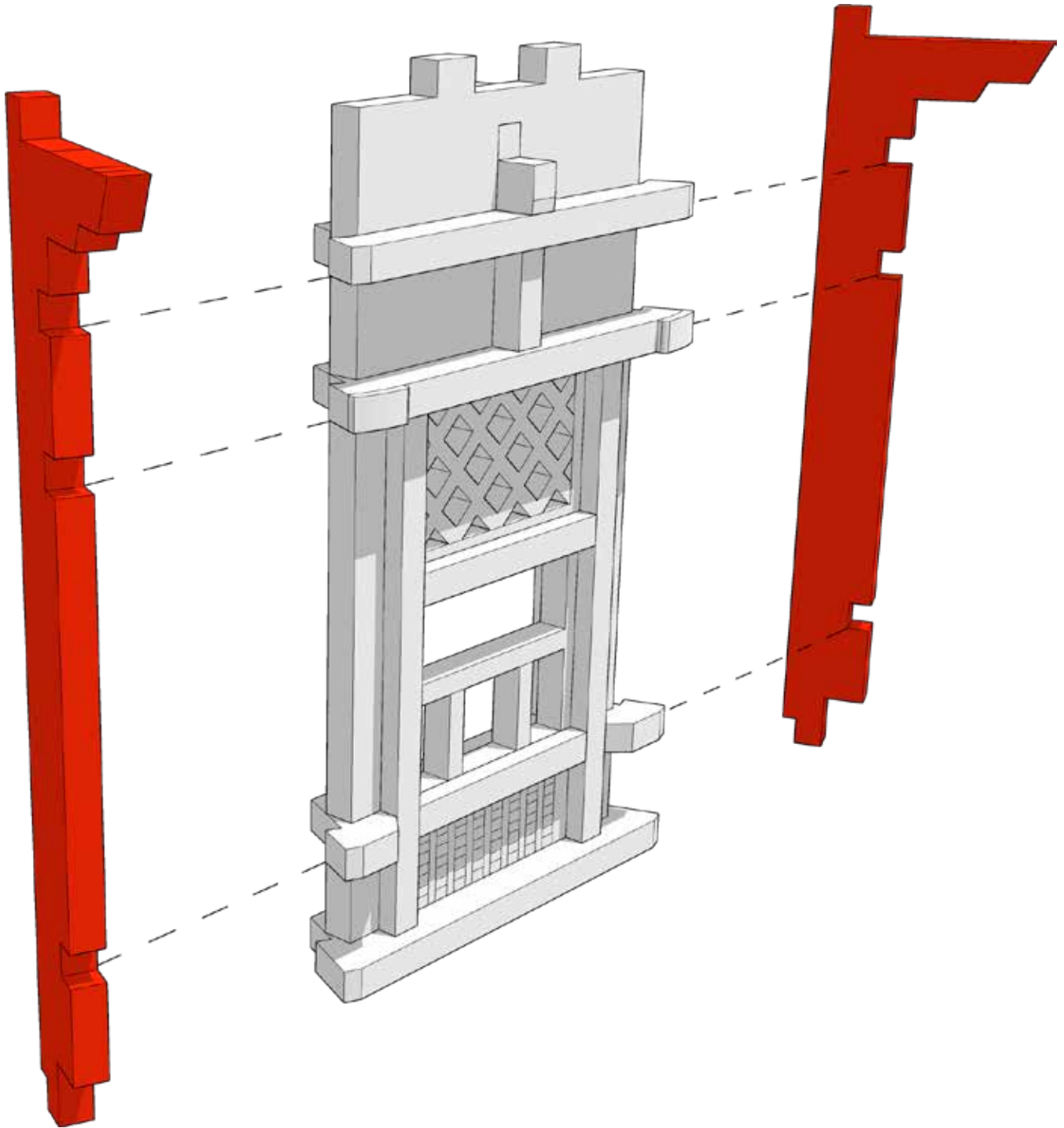



TABLETOP SCENICS

TTSCW-EES-110
Toshi
Hakkei-tō Pagoda

137

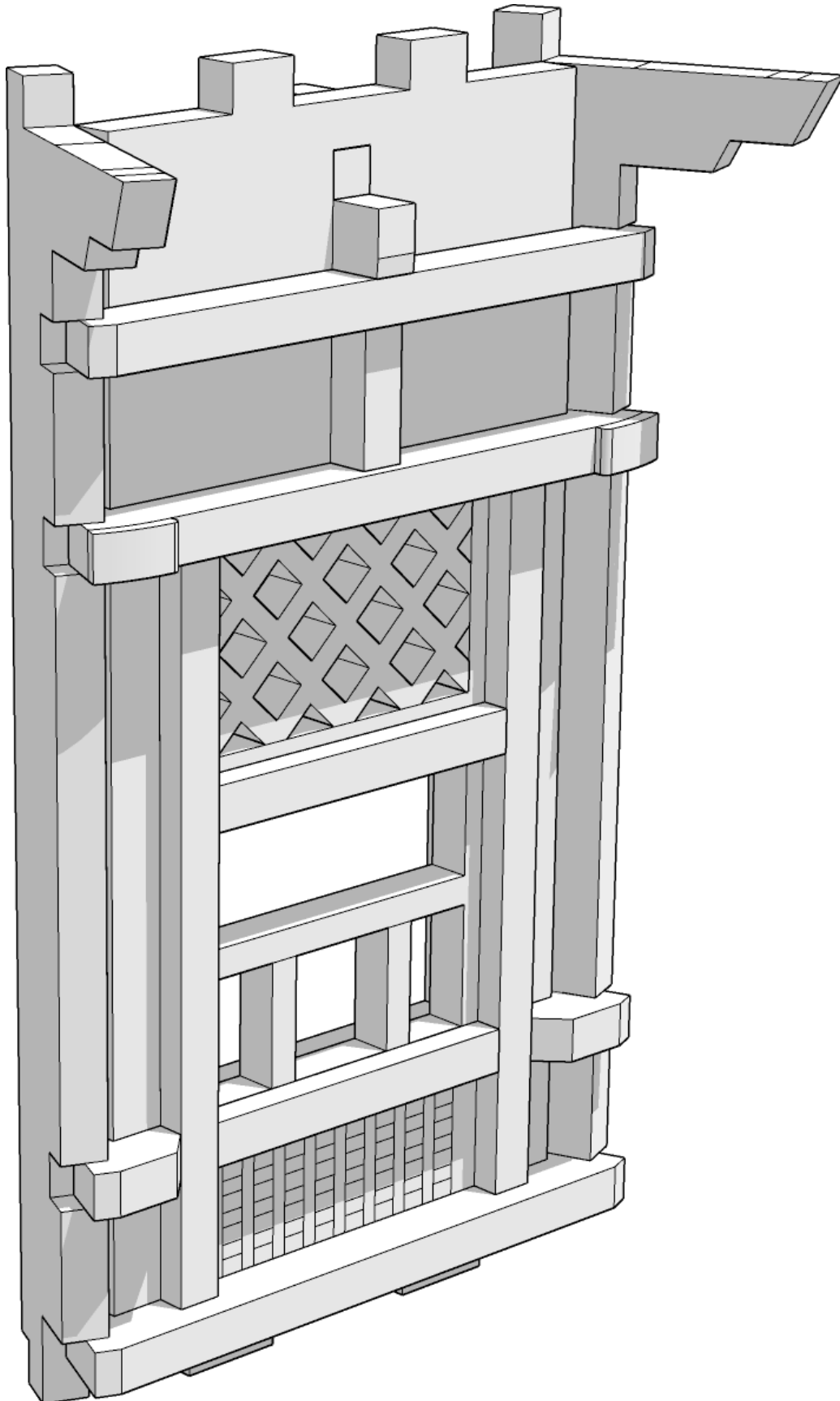



TABLETOP SCENICS

138

TTSCW-EES-110
Toshi
Hakkei-tō Pagoda

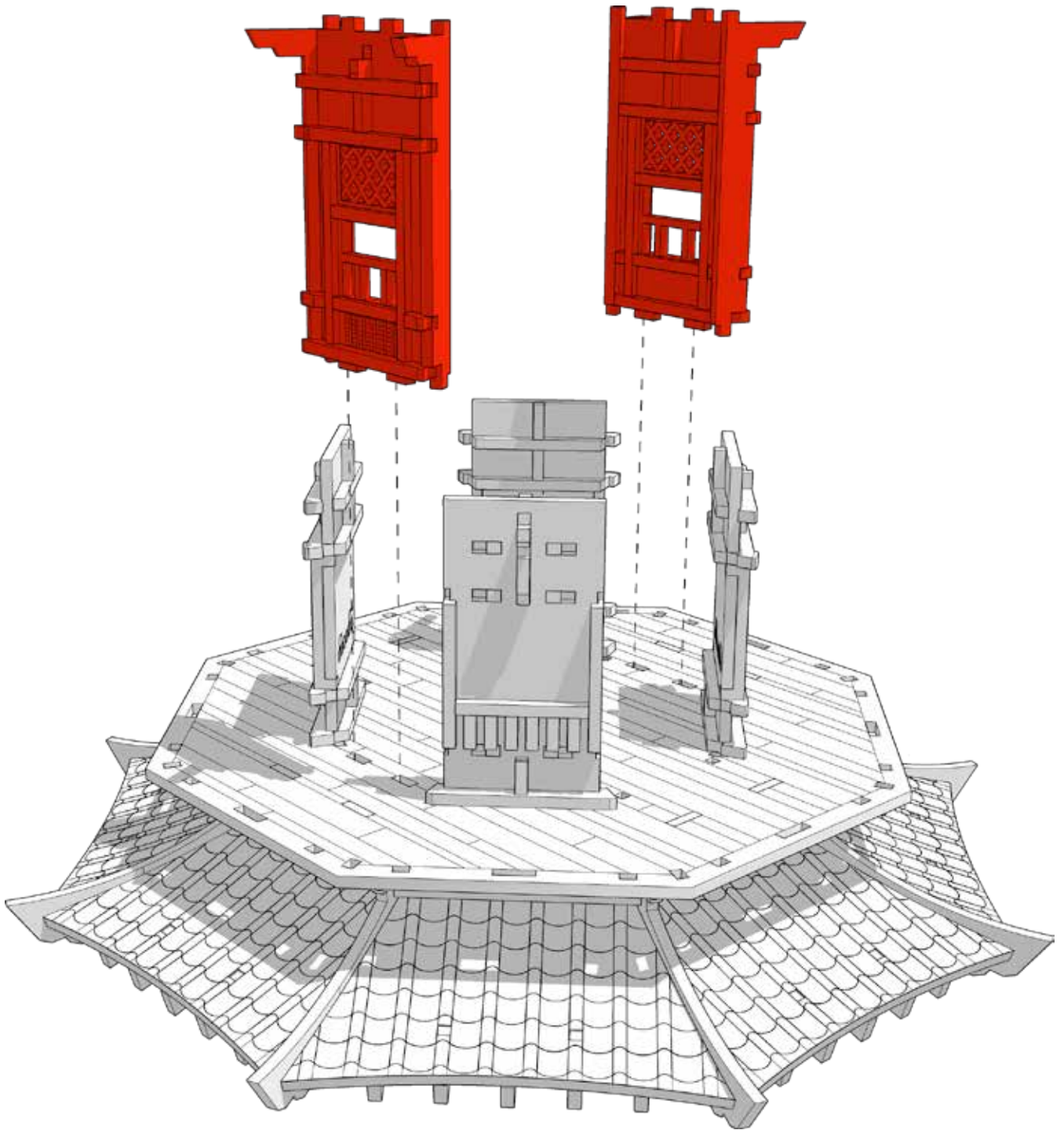



TABLETOP SCENICS

TTSCW-EES-110
Toshi
Hakkei-tō Pagoda

139

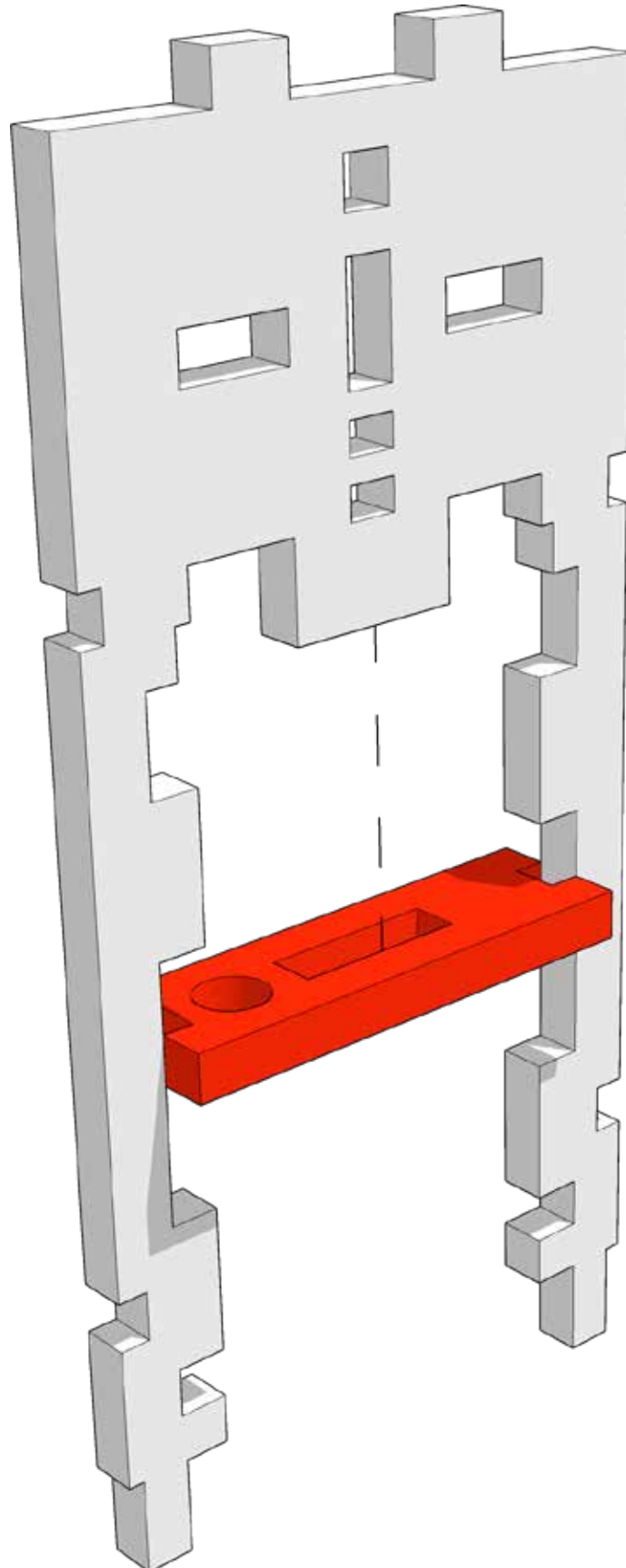



TABLETOP SCENICS

TTSCW-EES-110
Toshi
Hakkei-tō Pagoda

140

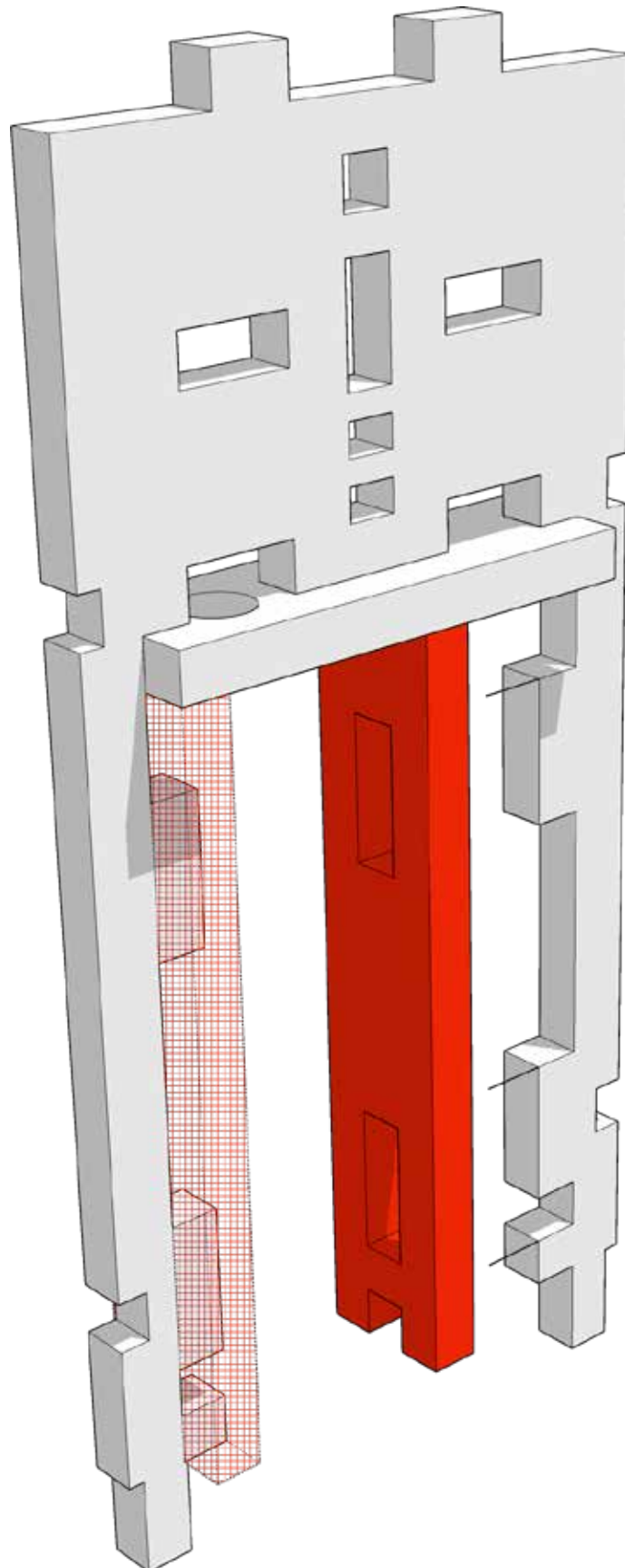

Repeat step for both sides



TABLETOP SCENICS

TTSCW-EES-110
Toshi
Hakkei-tō Pagoda

141

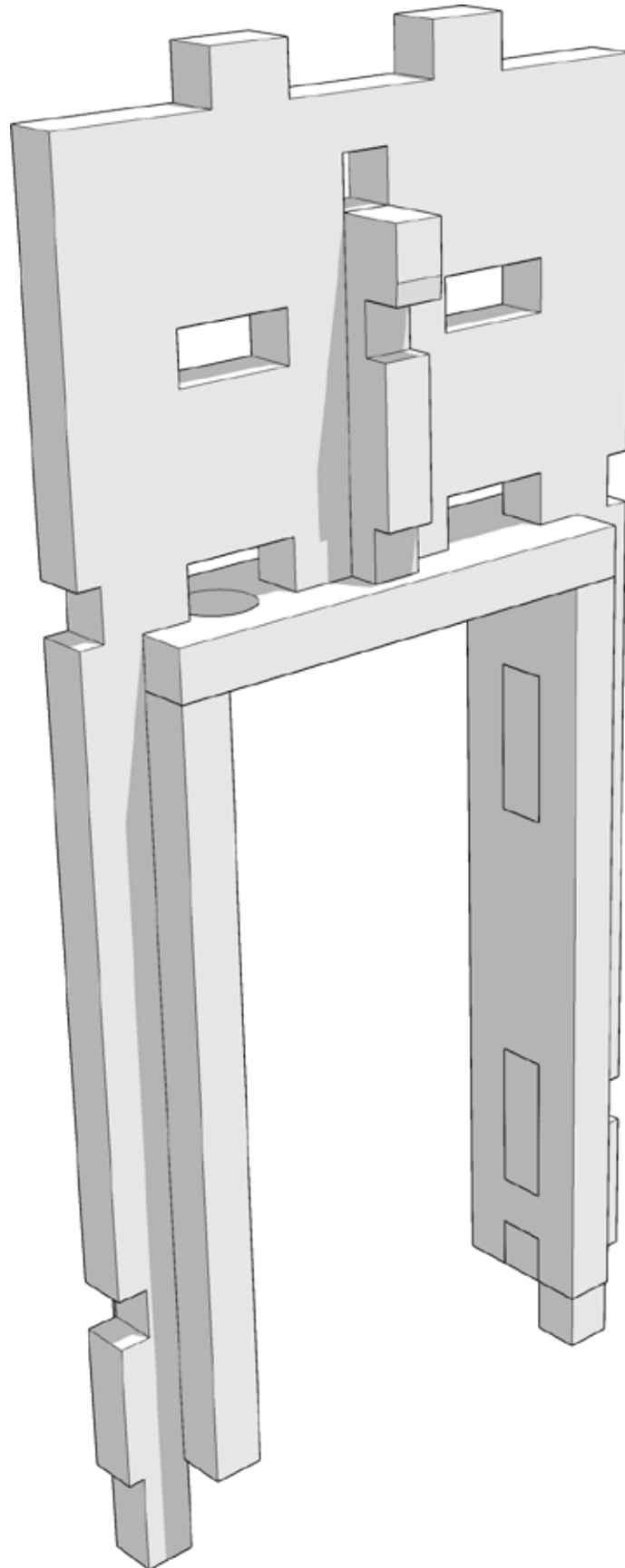



TABLETOP SCENICS

TTSCW-EES-110
Toshi
Hakkei-tō Pagoda

142

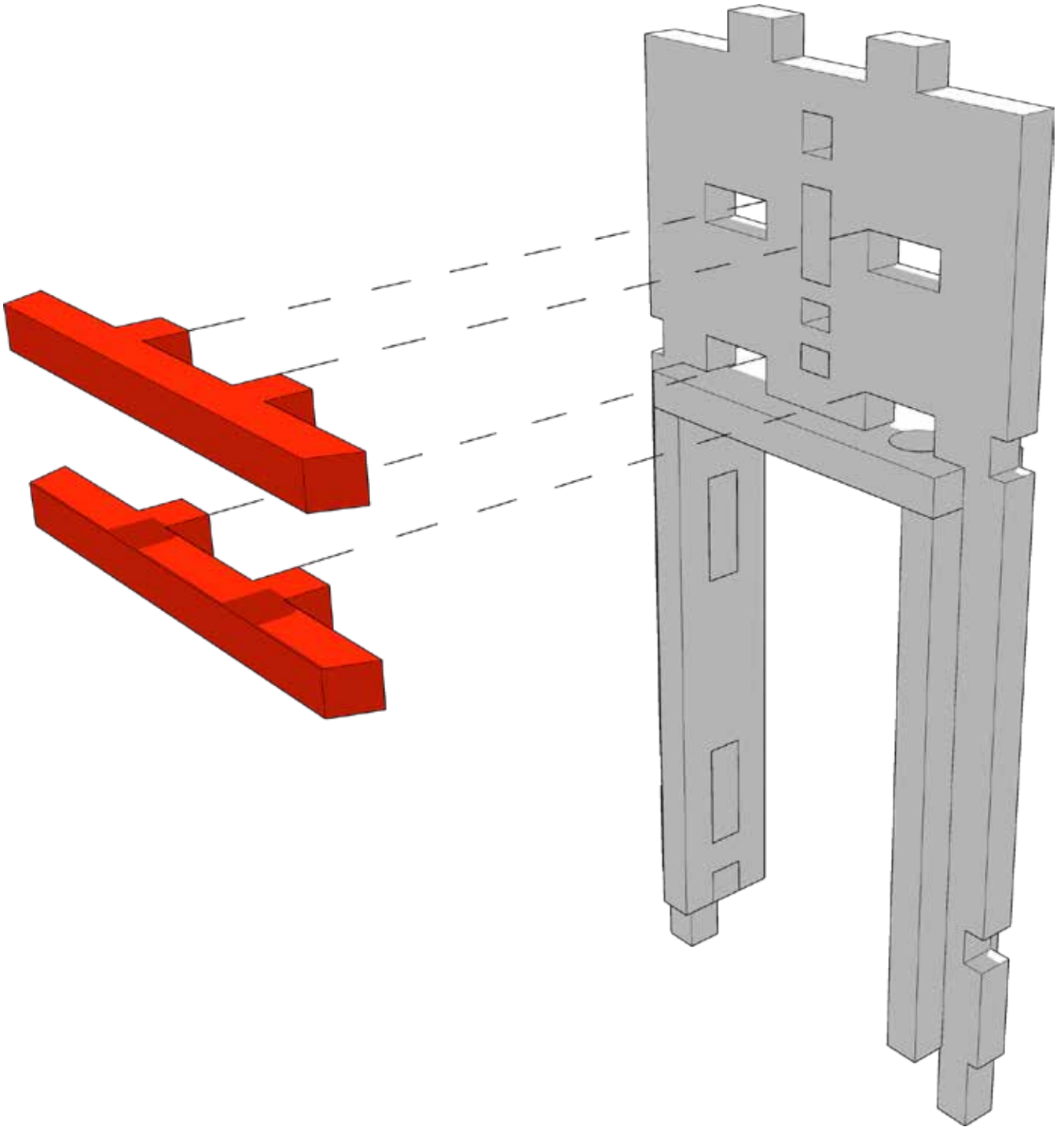



TABLETOP SCENICS

TTSCW-EES-110
Toshi
Hakkei-tō Pagoda

143

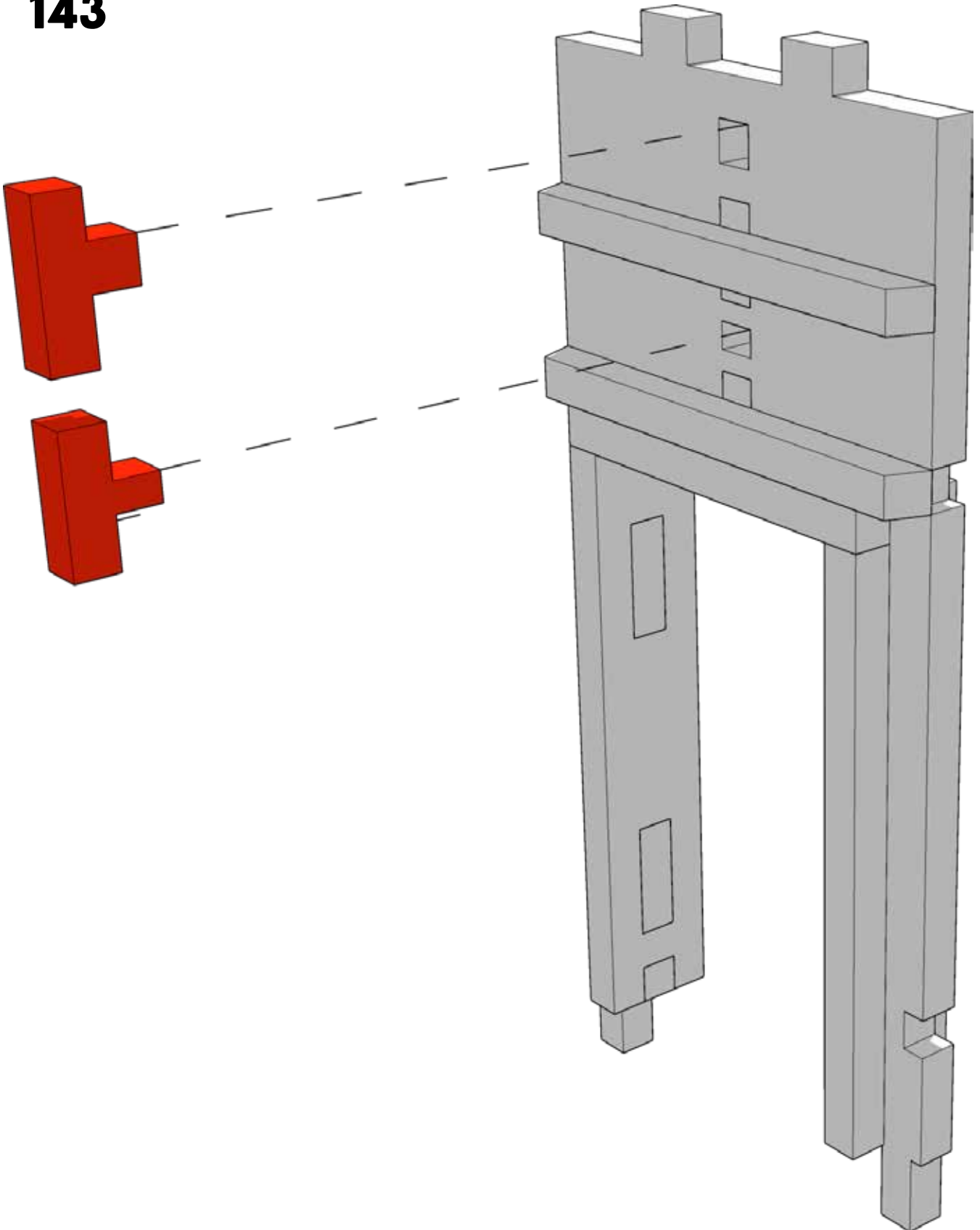



TABLETOP SCENICS

TTSCW-EES-110
Toshi
Hakkei-tō Pagoda

144

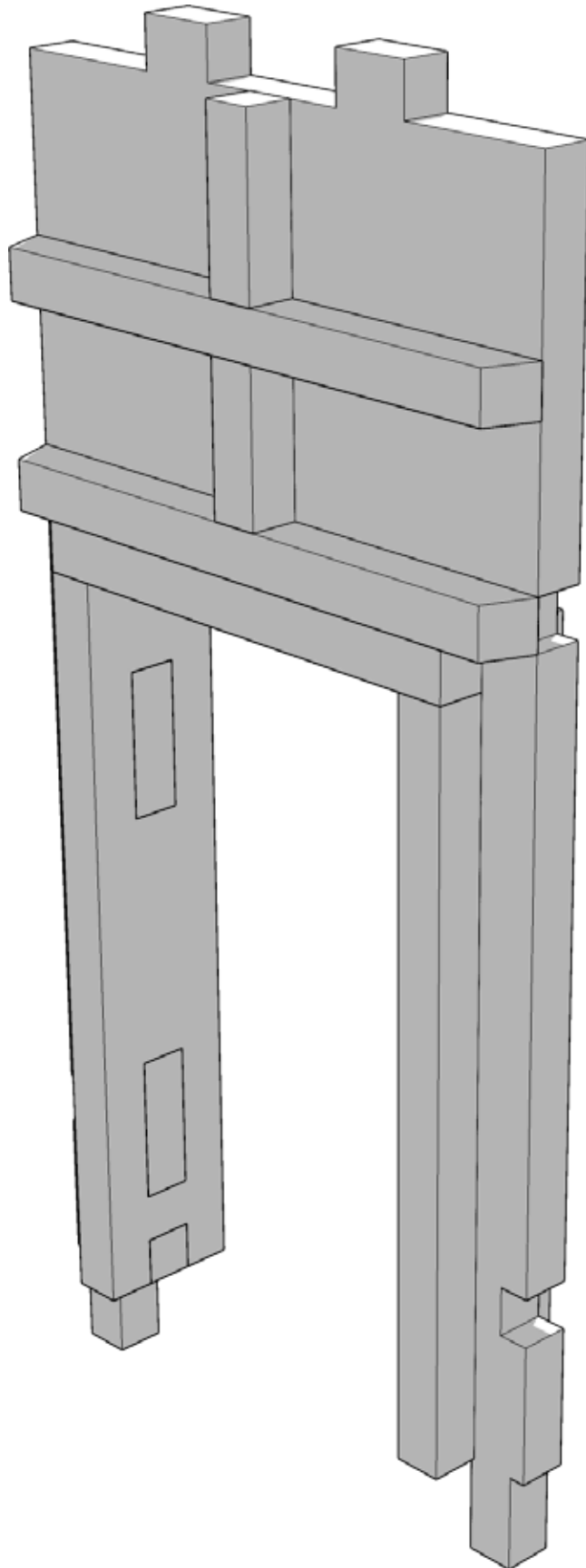



TABLETOP SCENICS

TTSCW-EES-110
Toshi
Hakkei-tō Pagoda

145

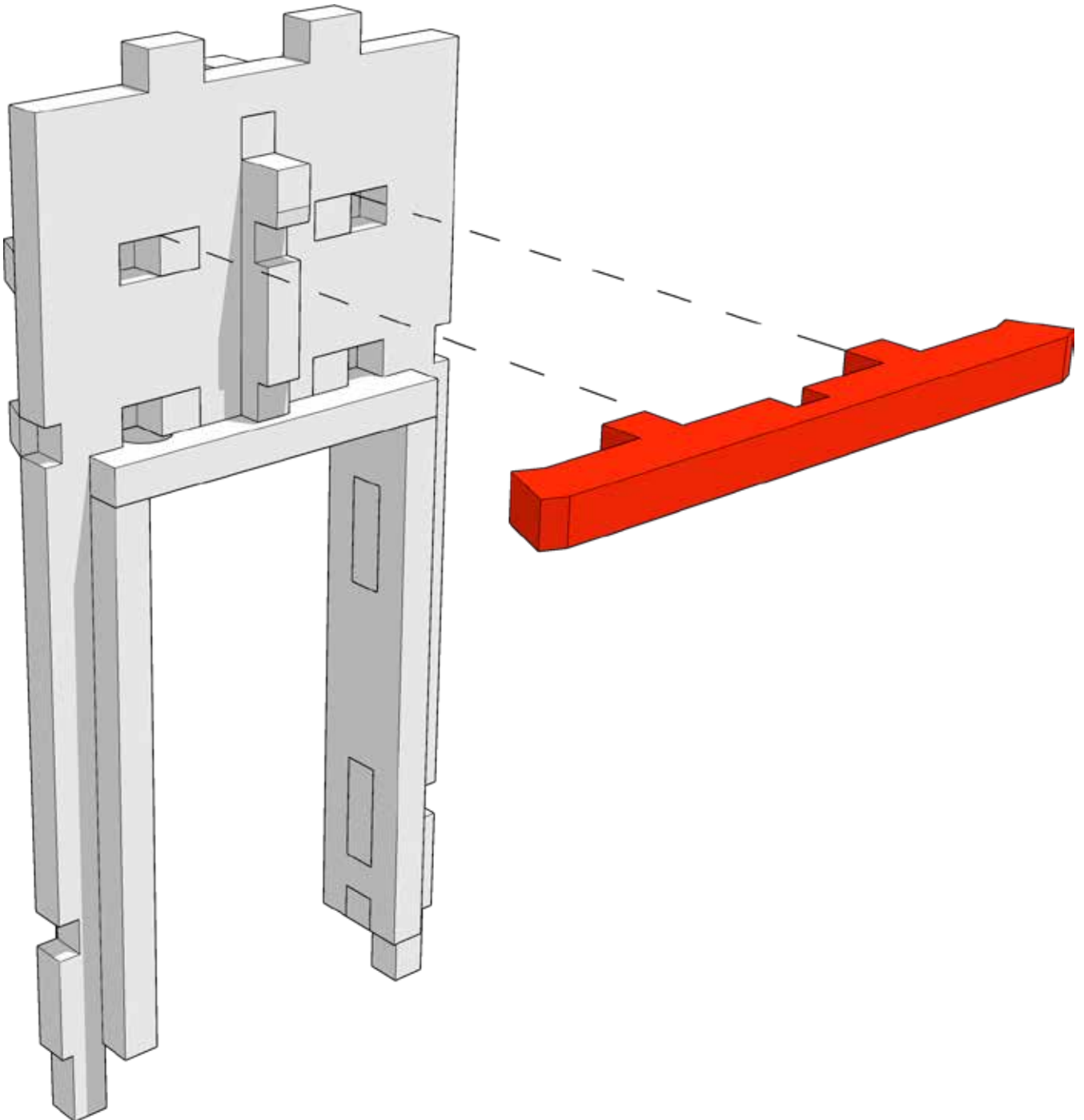



TABLETOP SCENICS

TTSCW-EES-110
Toshi
Hakkei-tō Pagoda

146

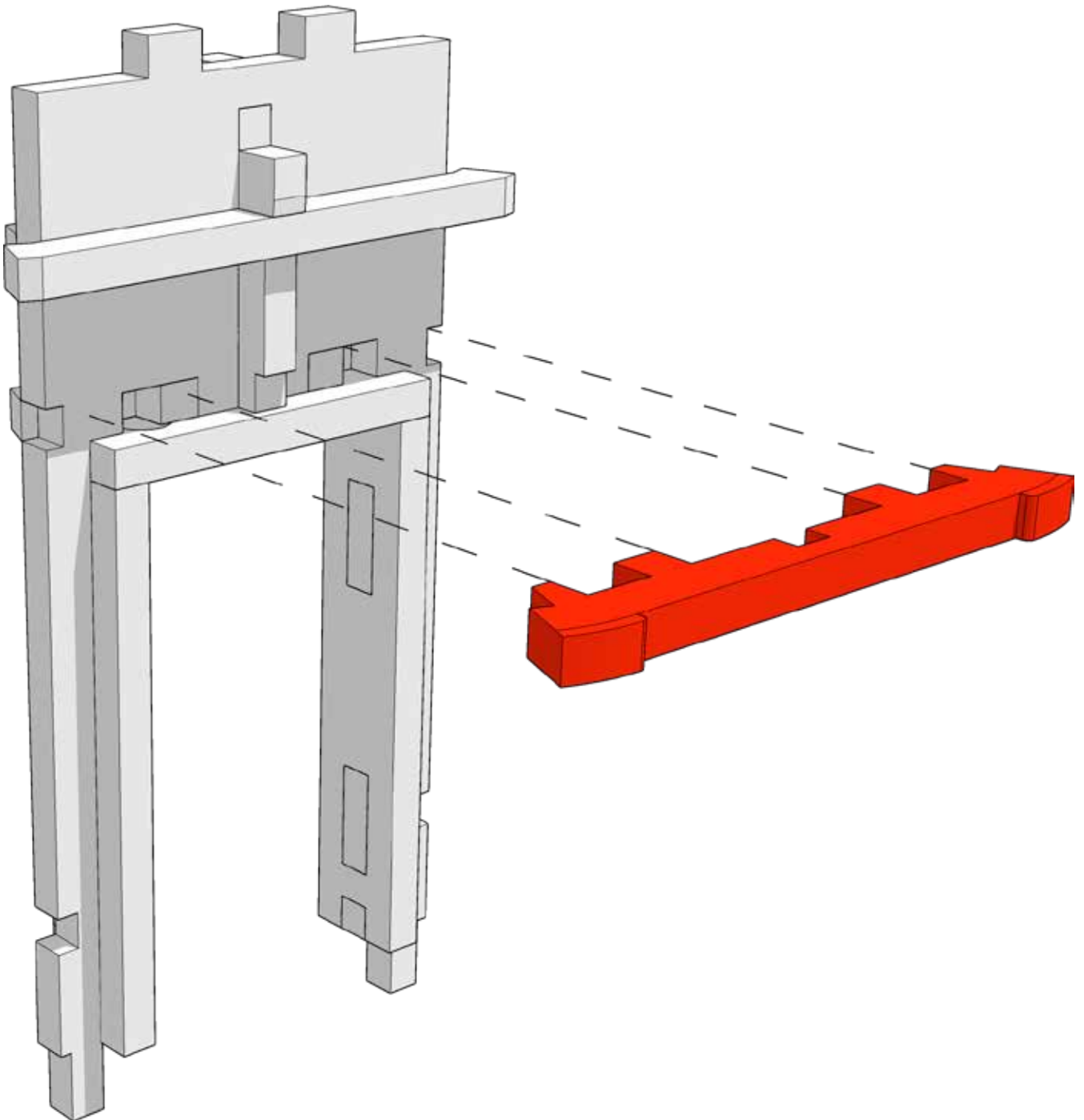



TABLETOP
SCENICS

TTSCW-EES-110
Toshi
Hakkei-tō Pagoda

147

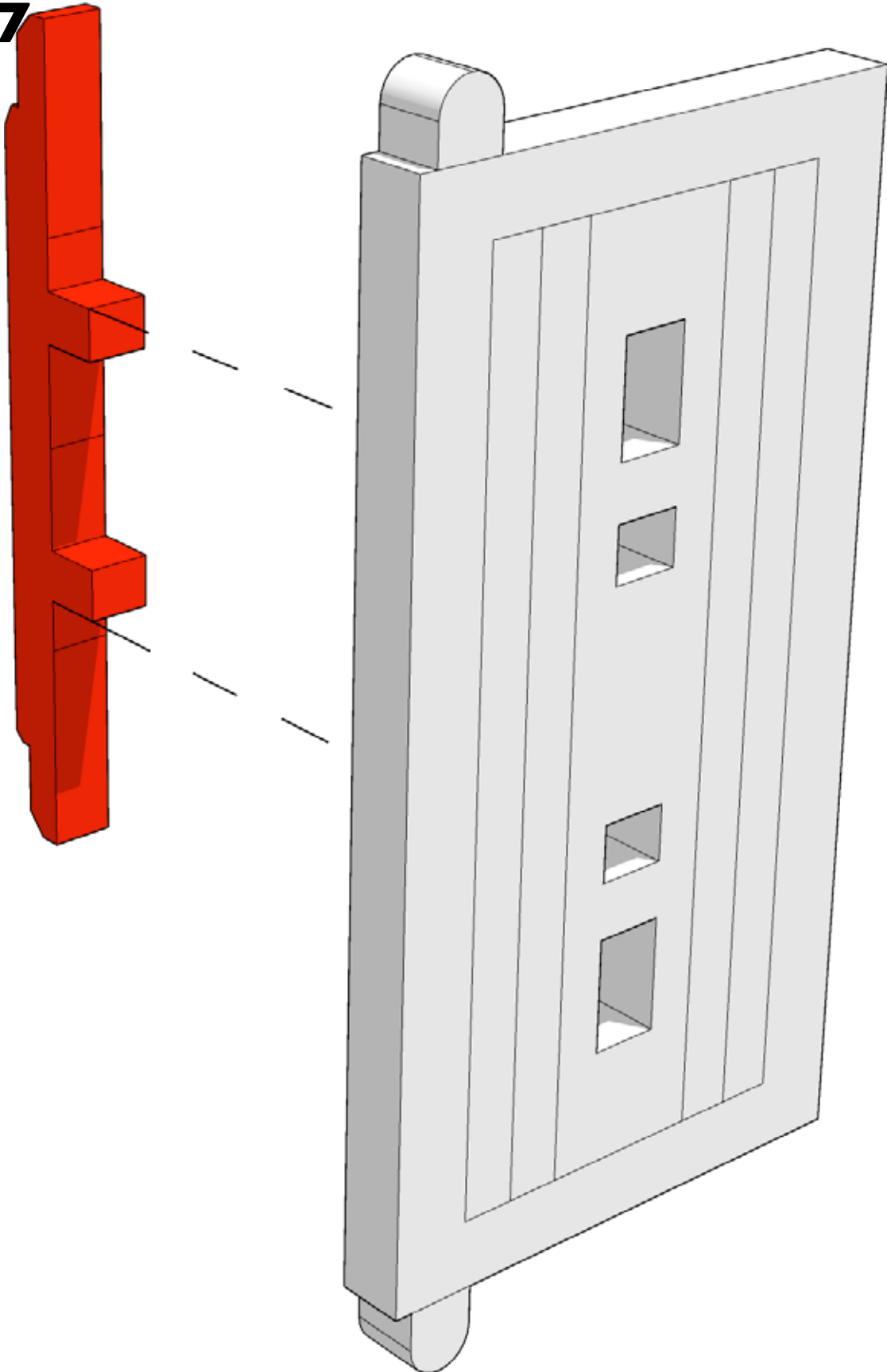



TABLETOP SCENICS

TTSCW-EES-110
Toshi
Hakkei-tō Pagoda

14

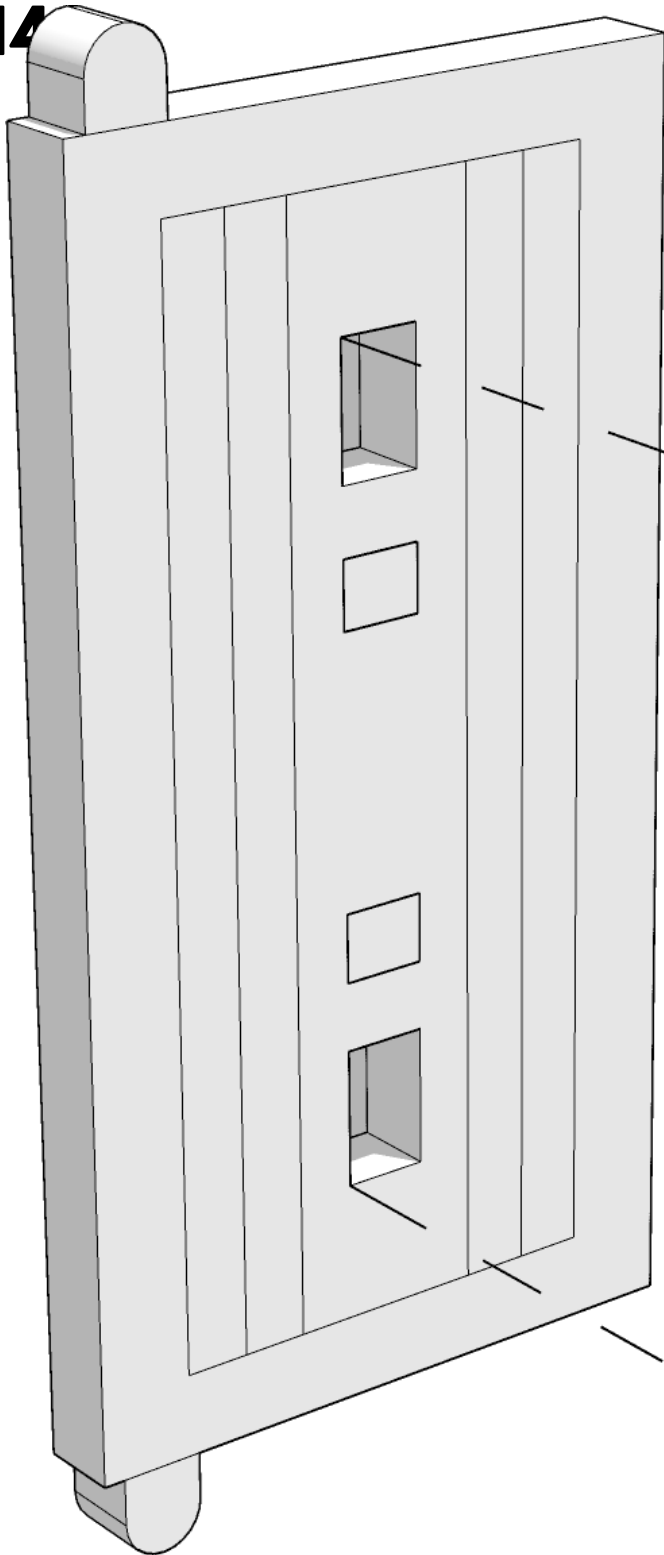



TABLETOP SCENICS

TTSCW-EES-110
Toshi
Hakkei-tō Pagoda

149

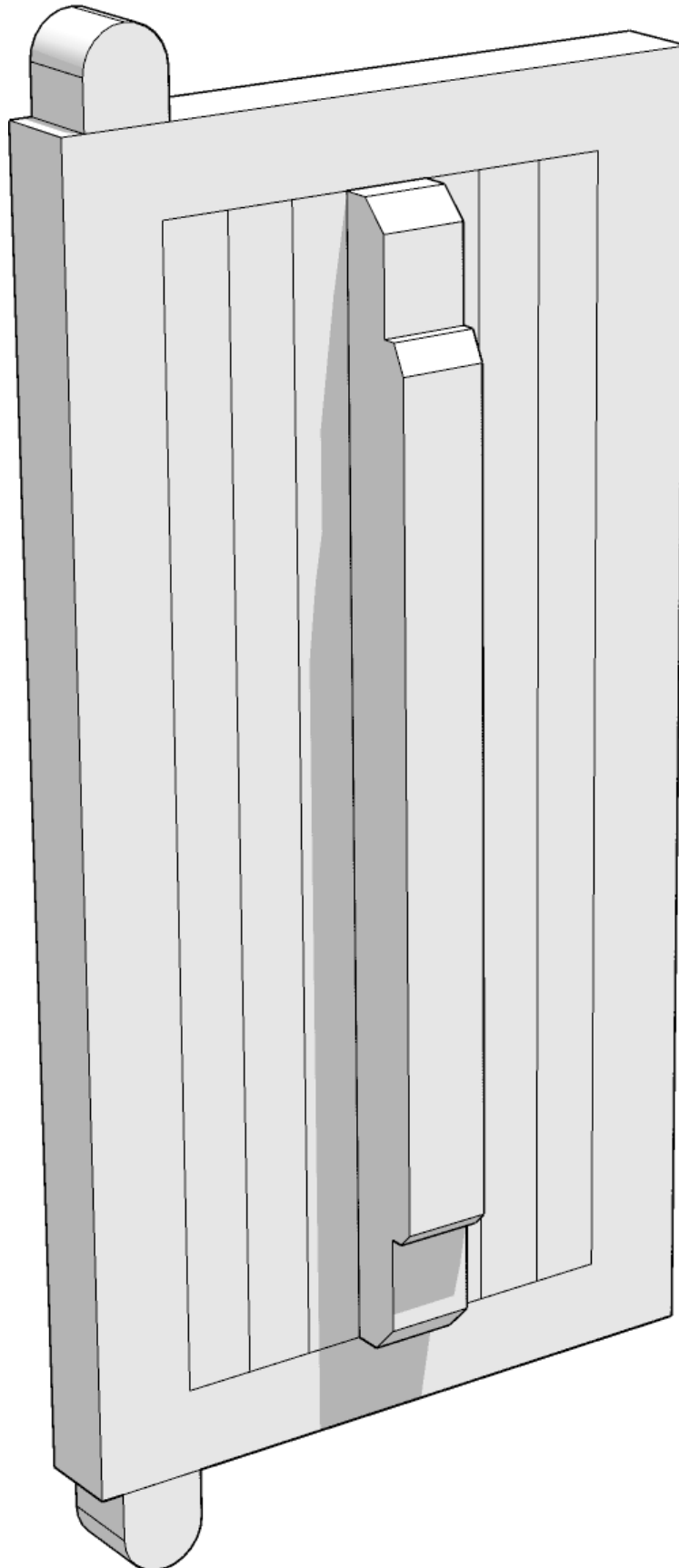



TABLETOP SCENICS

TTSCW-EES-110
Toshi
Hakkei-tō Pagoda

150

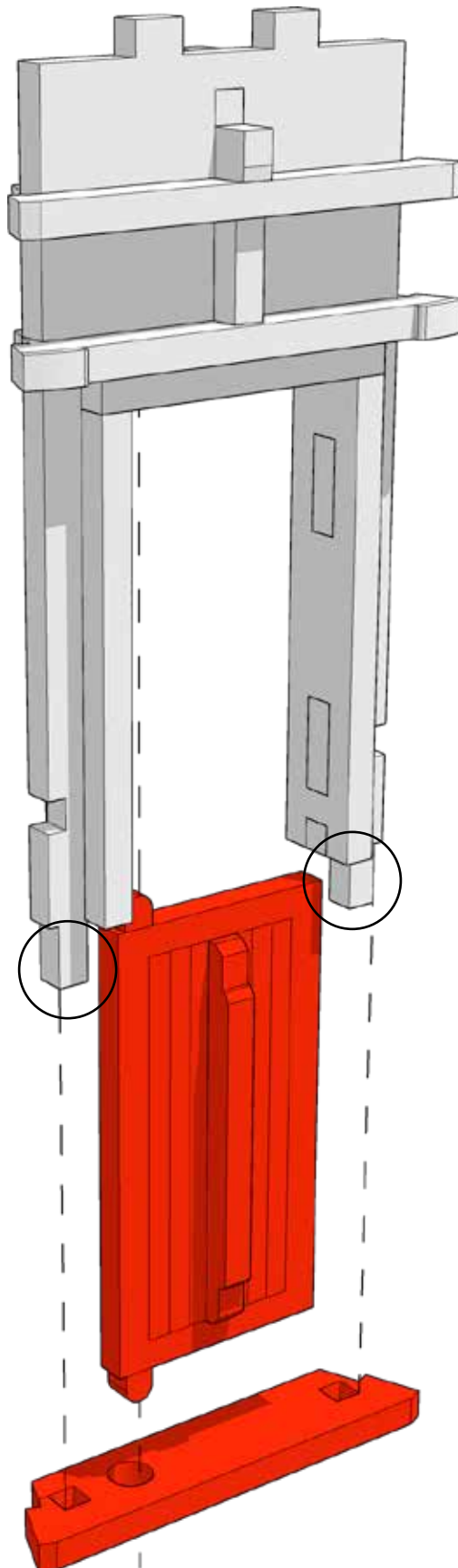

Do not glue the door. Only the square tabs
circled



TABLETOP SCENICS

TTSCW-EES-110
Toshi
Hakkei-tō Pagoda

151

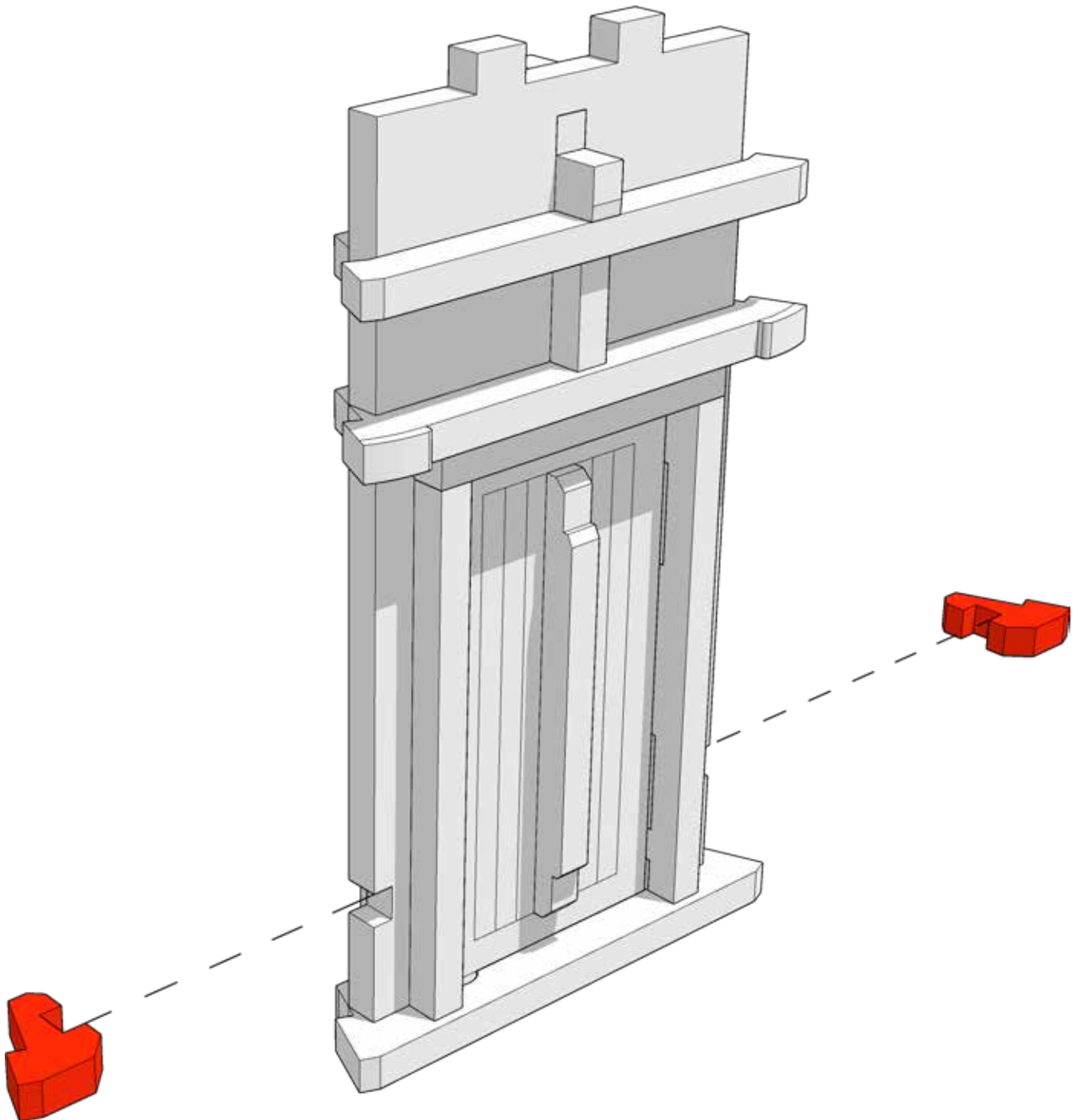

Highlighted parts can be found on
sheet 14



TABLETOP SCENICS

TTSCW-EES-110
Toshi
Hakkei-tō Pagoda

152

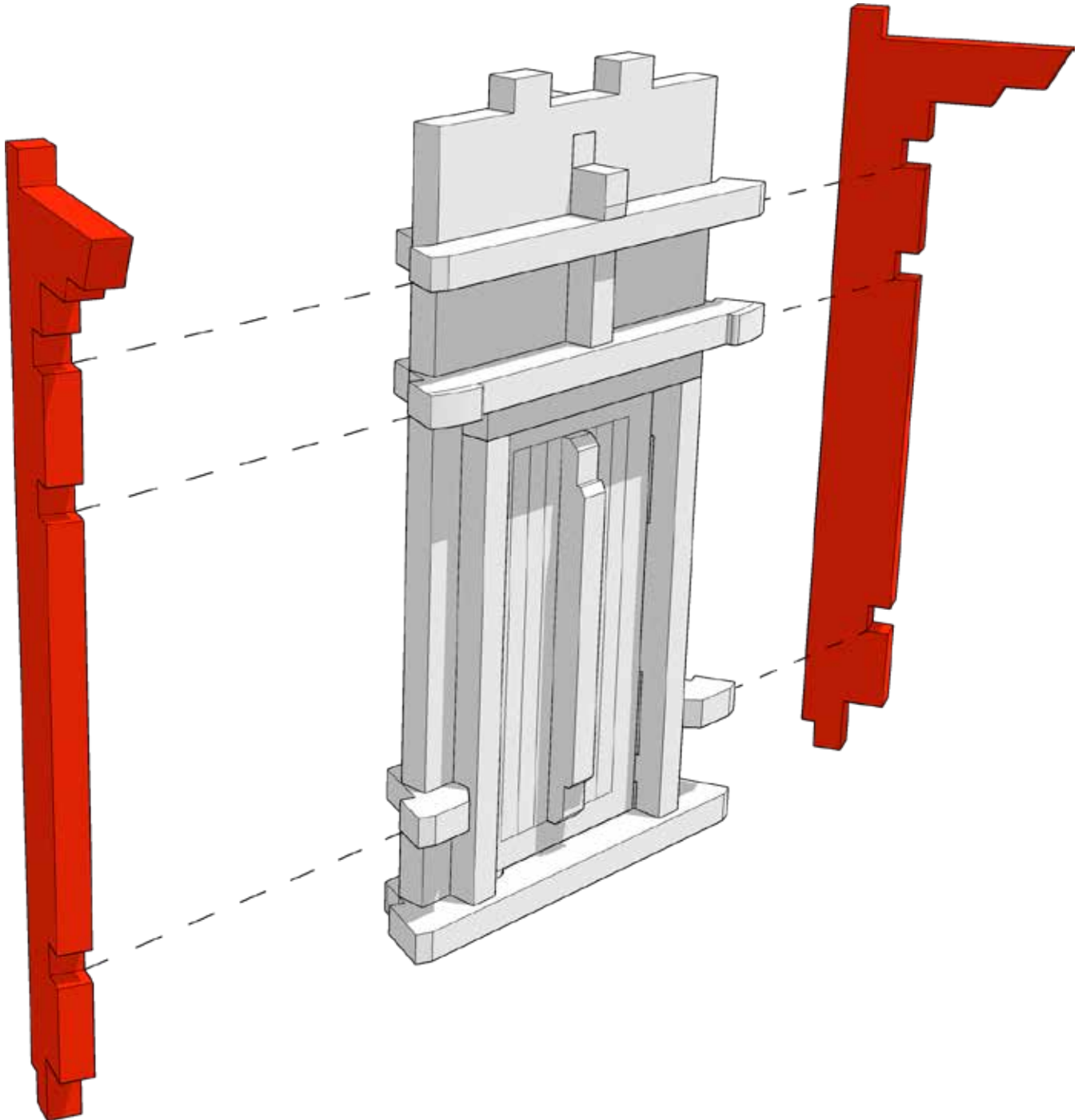



TABLETOP SCENICS

TTSCW-EES-110
Toshi
Hakkei-tō Pagoda

153

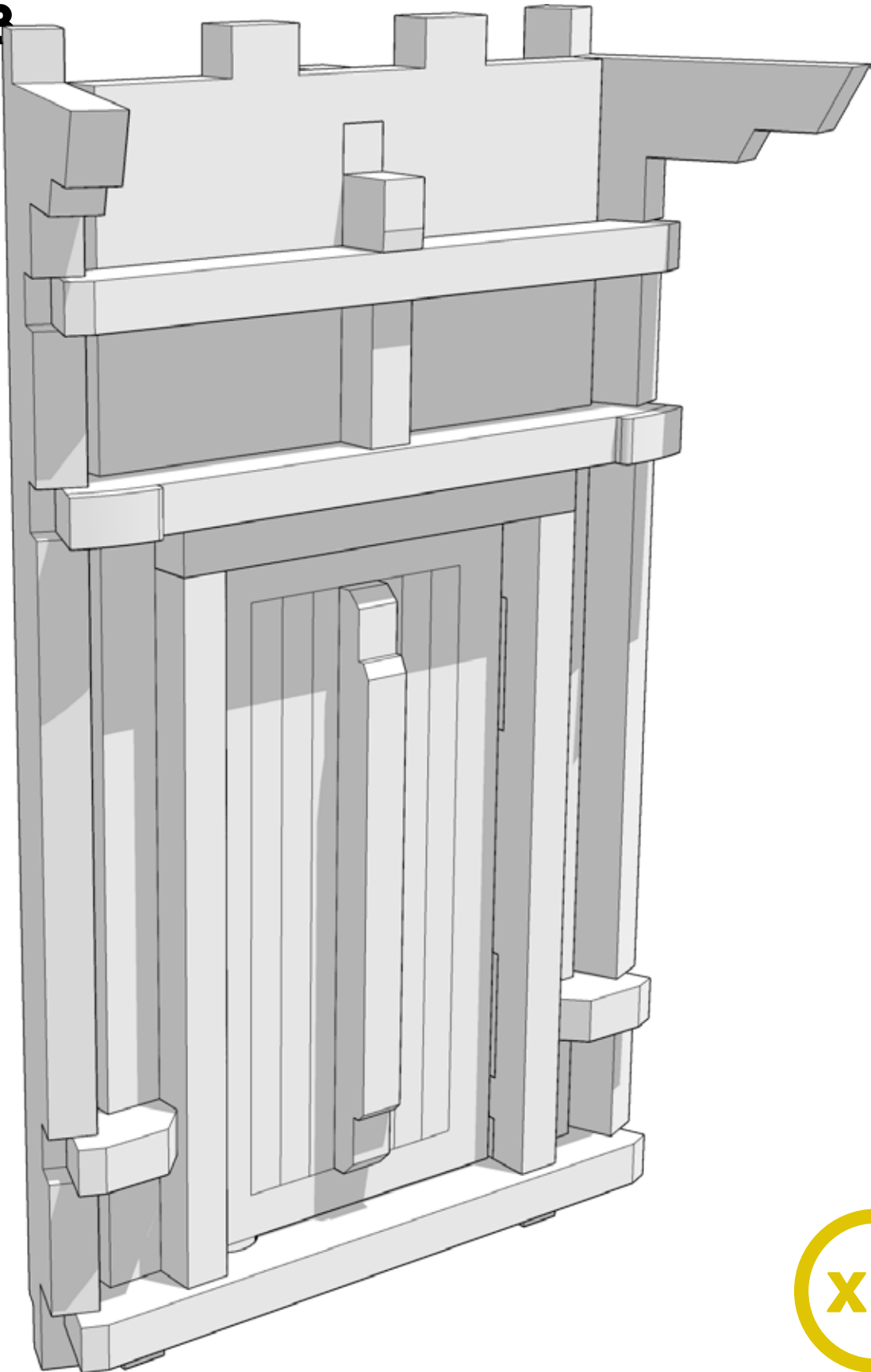

x2



TABLETOP SCENICS

TTSCW-EES-110
Toshi
Hakkei-tō Pagoda

154

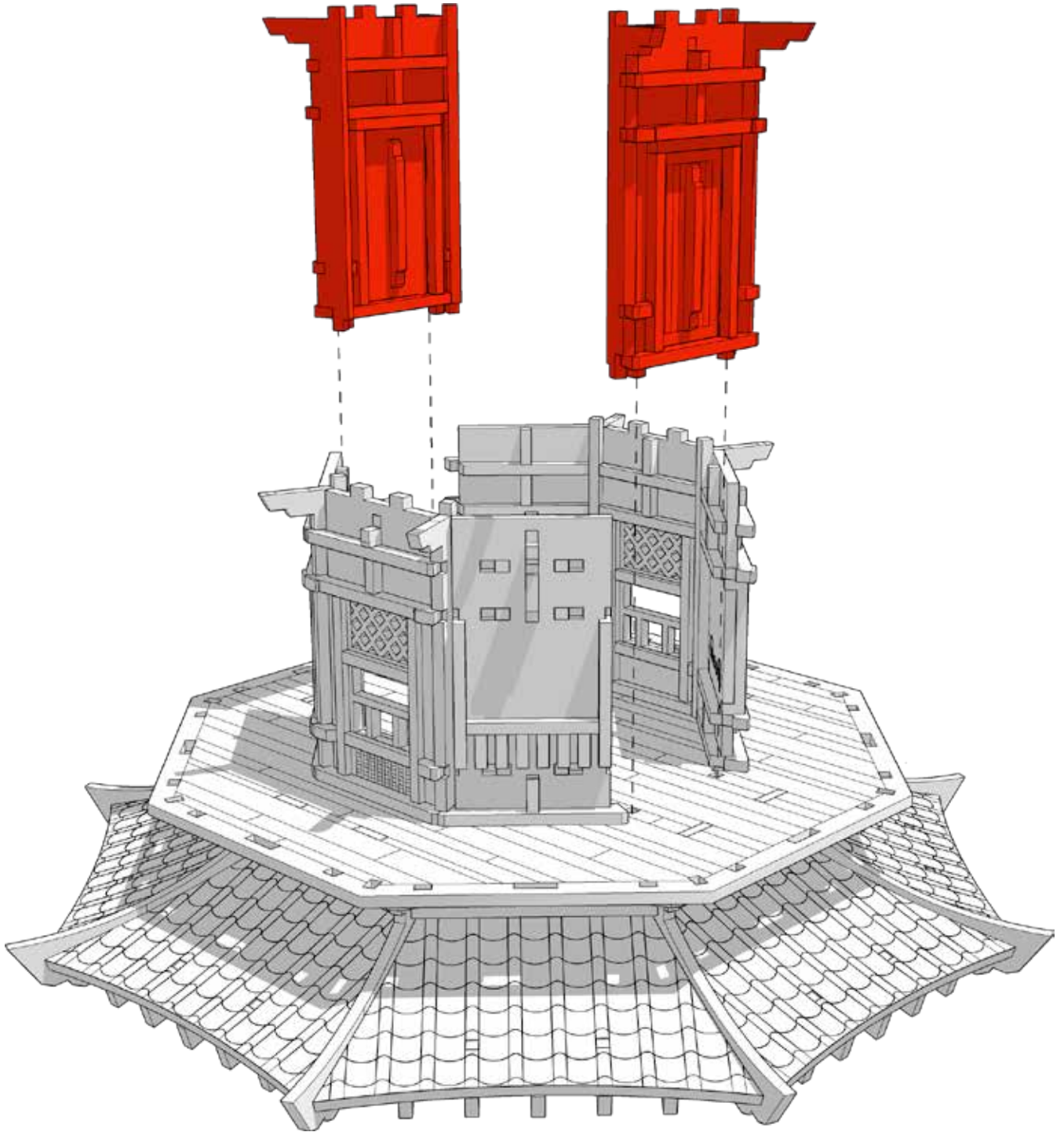



TABLETOP SCENICS

155

TTSCW-EES-110
Toshi
Hakkei-tō Pagoda

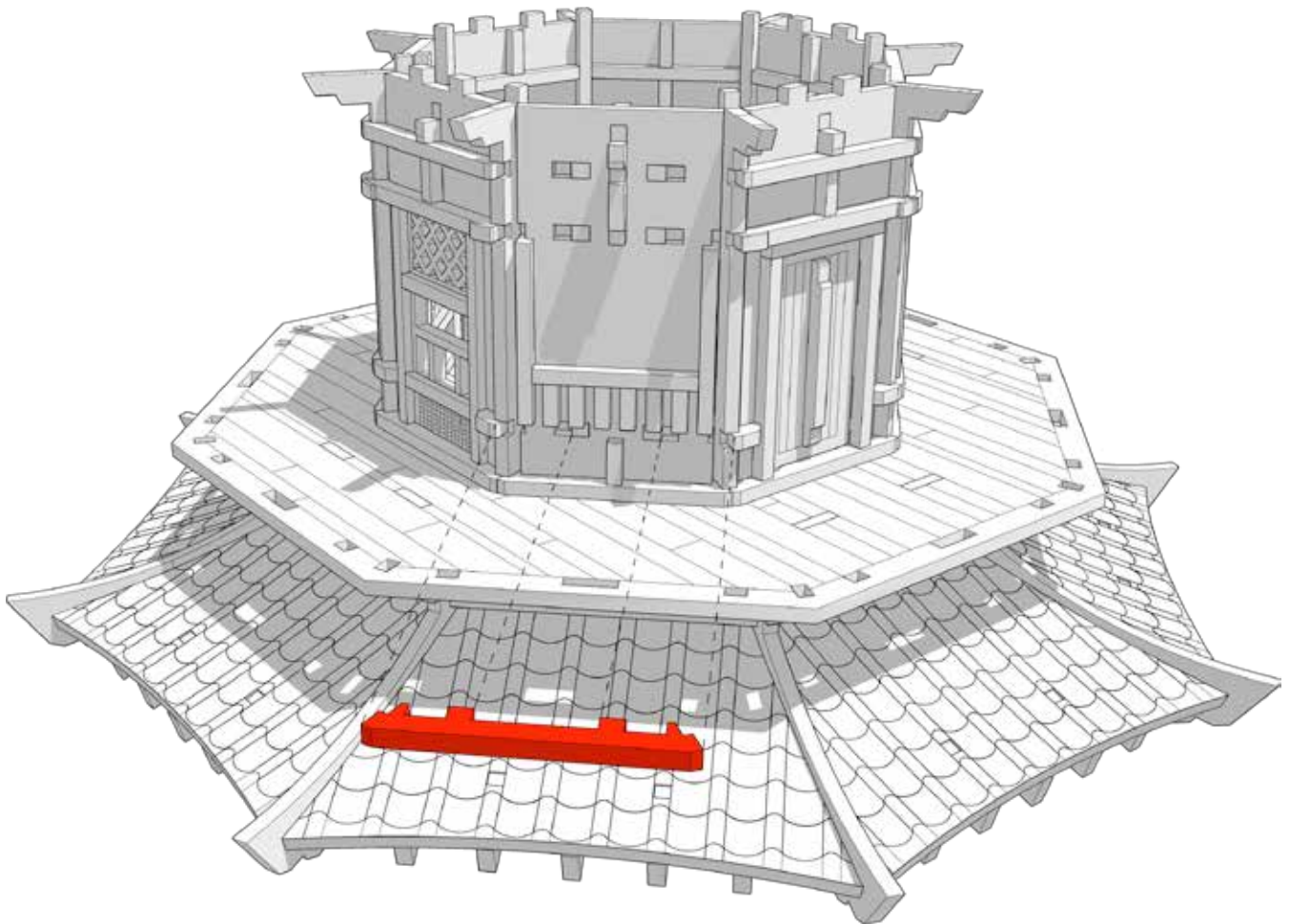

Repeat step for the 3 other same walls. It should align with the edges of the other walls to lock together





TABLETOP SCENICS

TTSCW-EES-110
Toshi
Hakkei-tō Pagoda

156

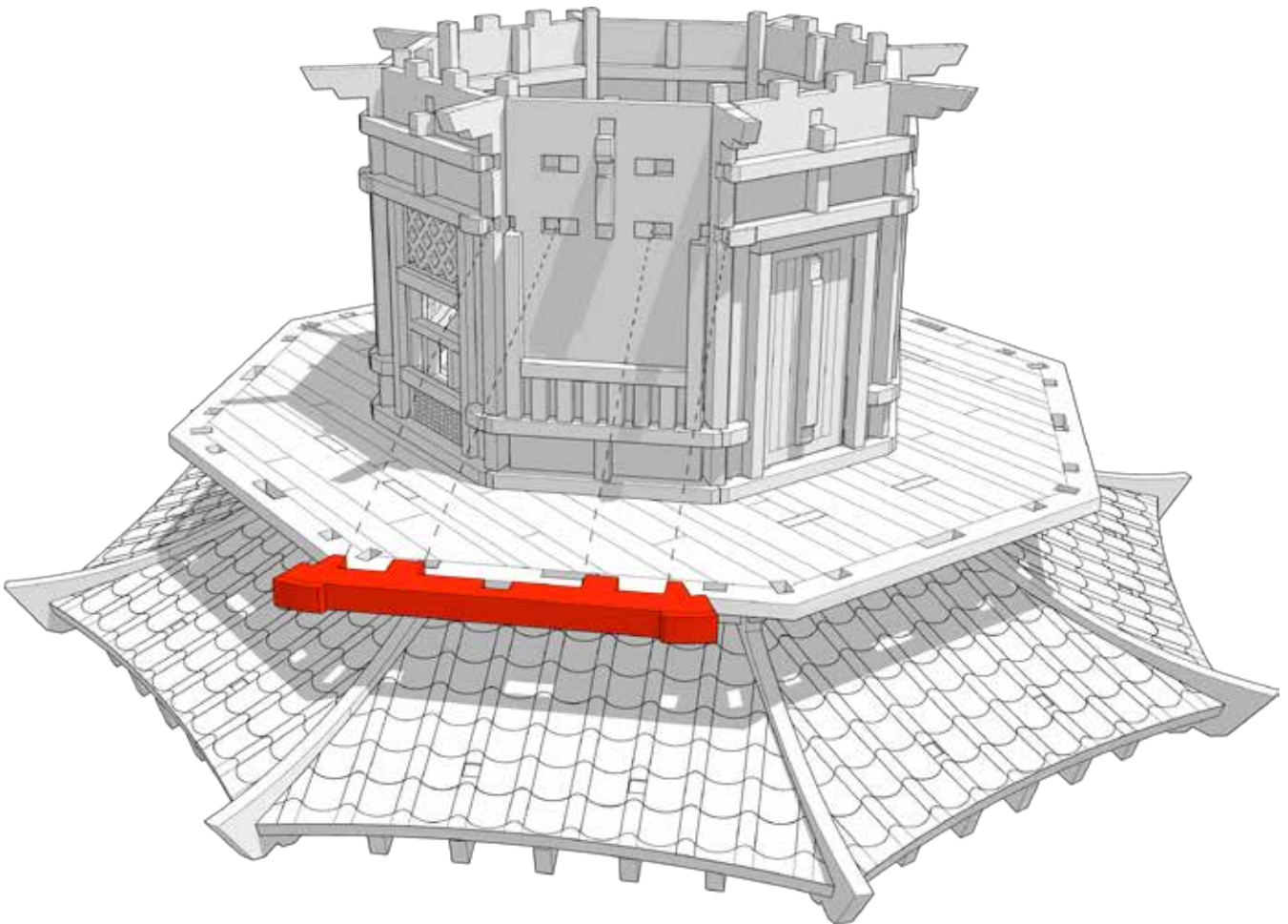

Repeat step for the 3 other same walls. It should align with the edges of the other walls to lock together

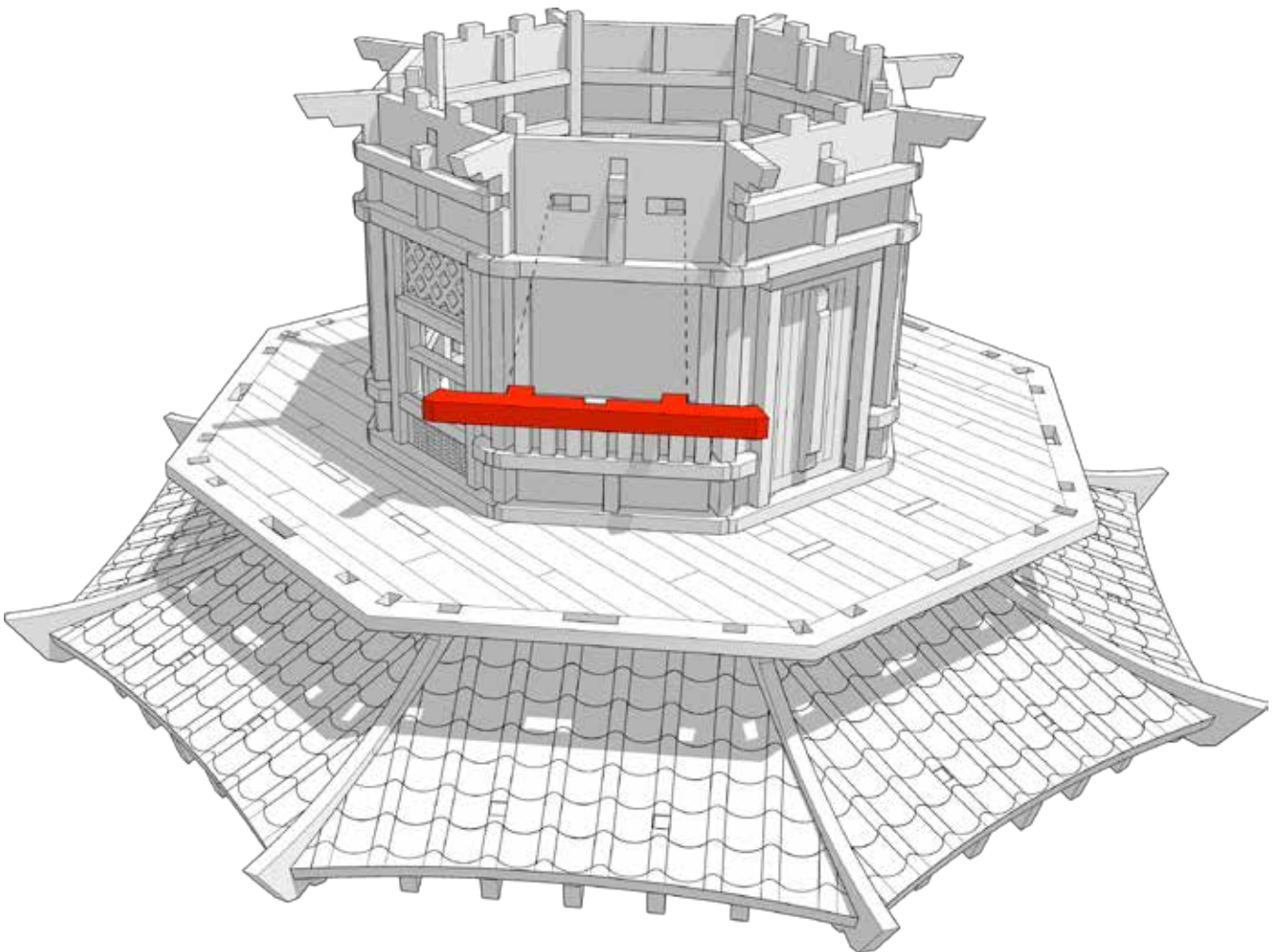

Repeat step for the 3 other same walls. It should align with the edges of the other walls to lock together



TABLETOP SCENICS

TTSCW-EES-110
Toshi
Hakkei-tō Pagoda

158

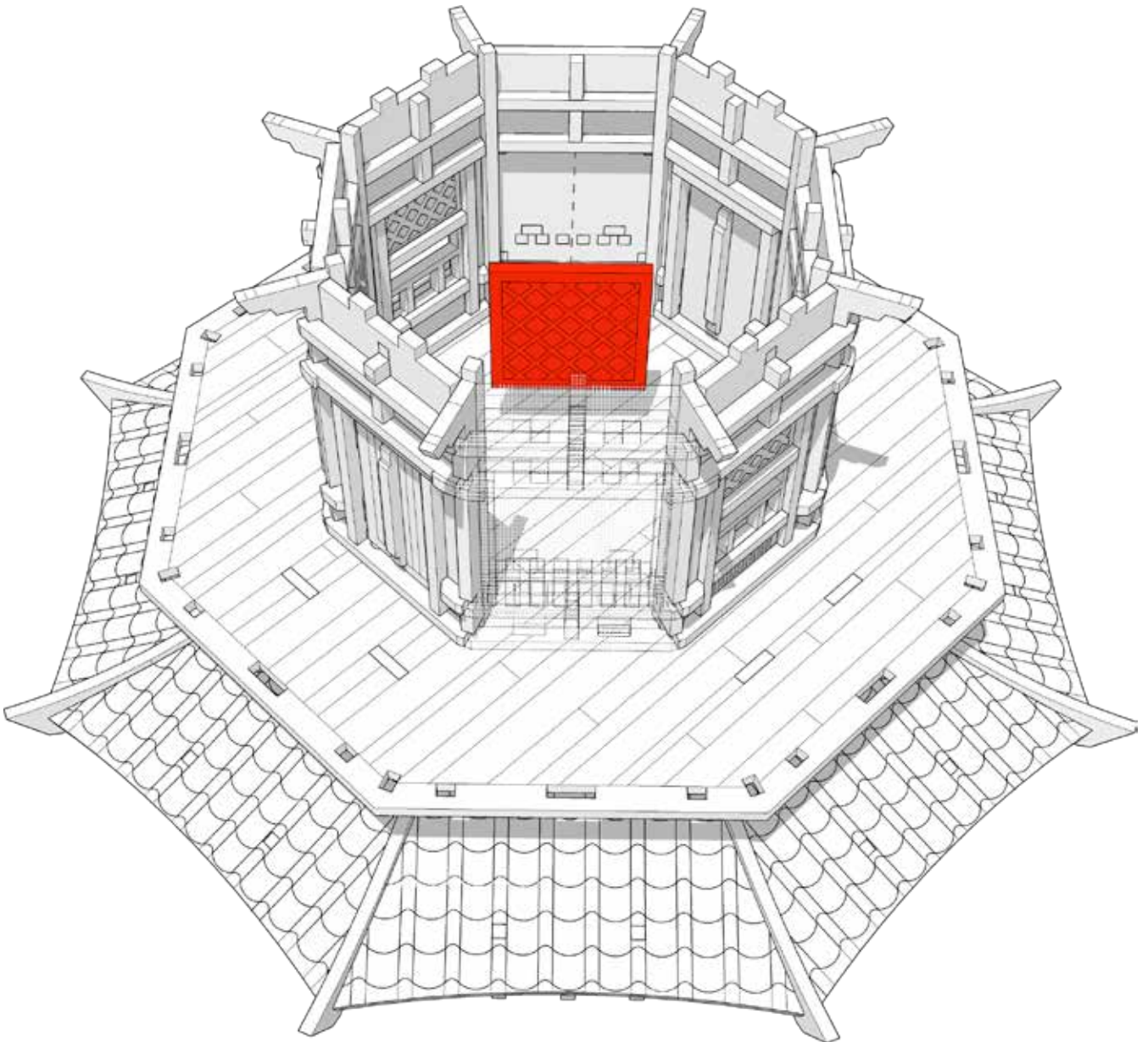

Repeat step for the other 3 spaces inside



TABLETOP SCENICS

159

TTSCW-EES-110
Toshi
Hakkei-tō Pagoda

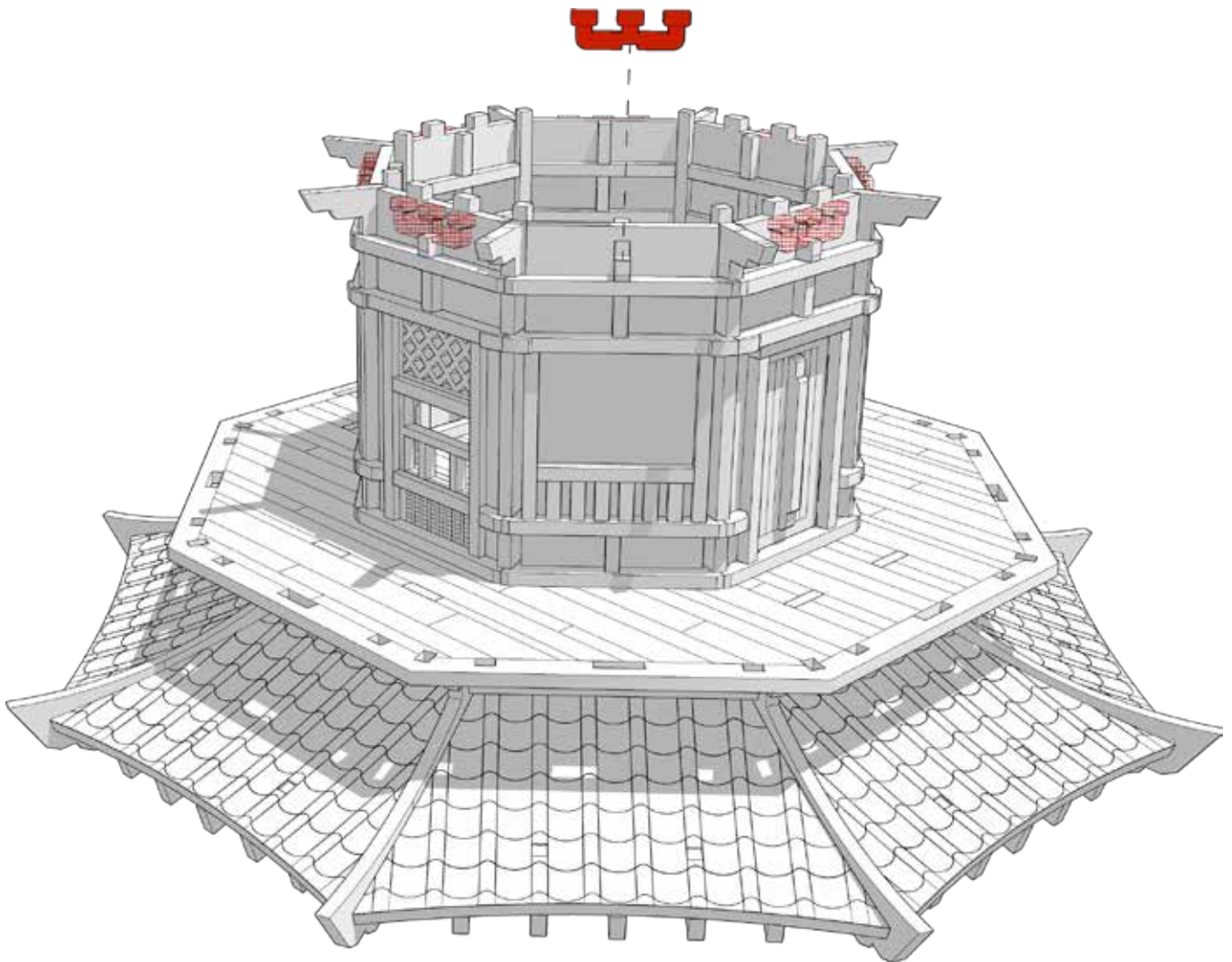

Repeat step around the building



TABLETOP SCENICS

160

TTSCW-EES-110
Toshi
Hakkei-tō Pagoda

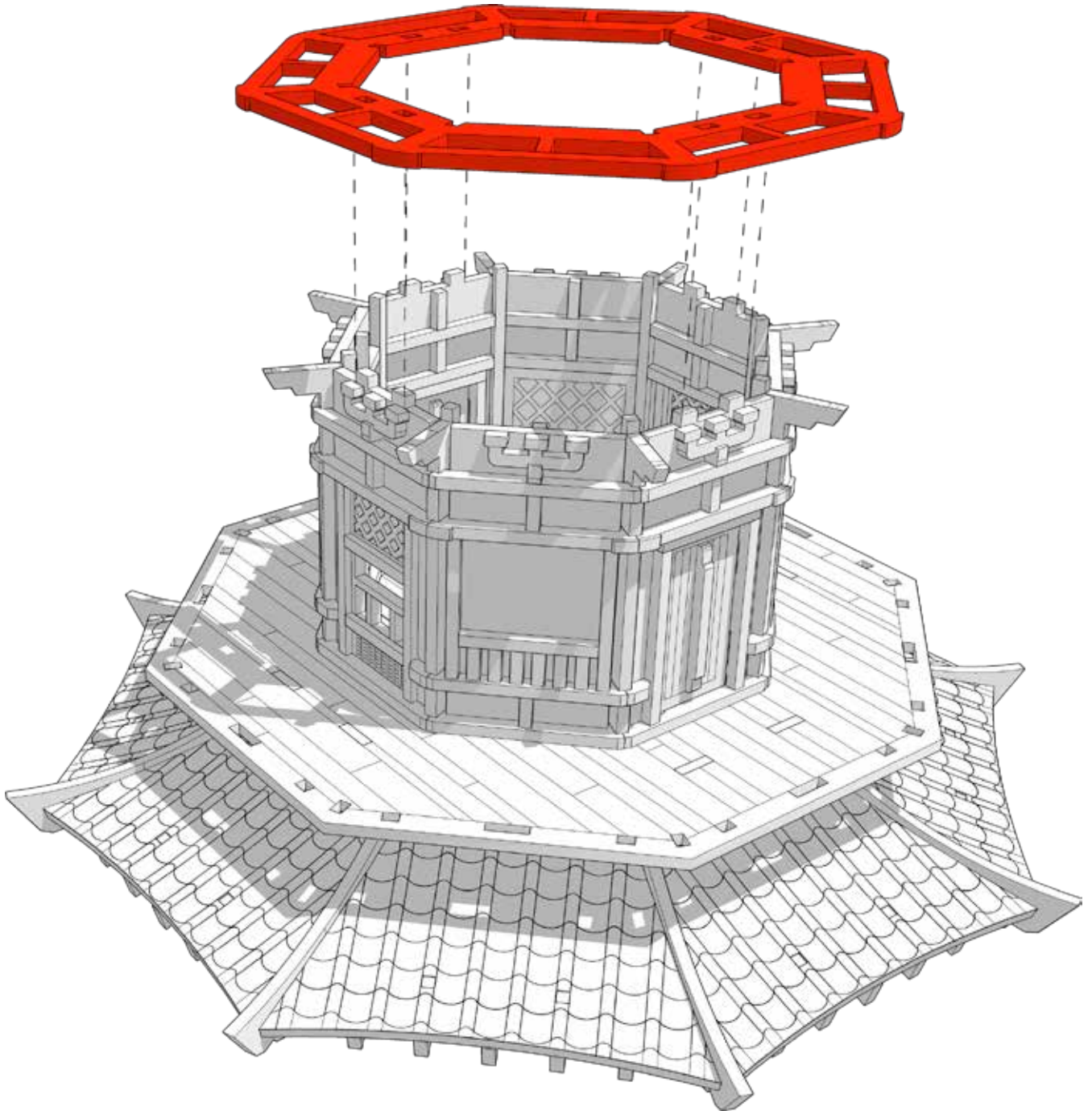



TABLETOP
SCENICS

TTSCW-EES-110
Toshi
Hakkei-tō Pagoda

161

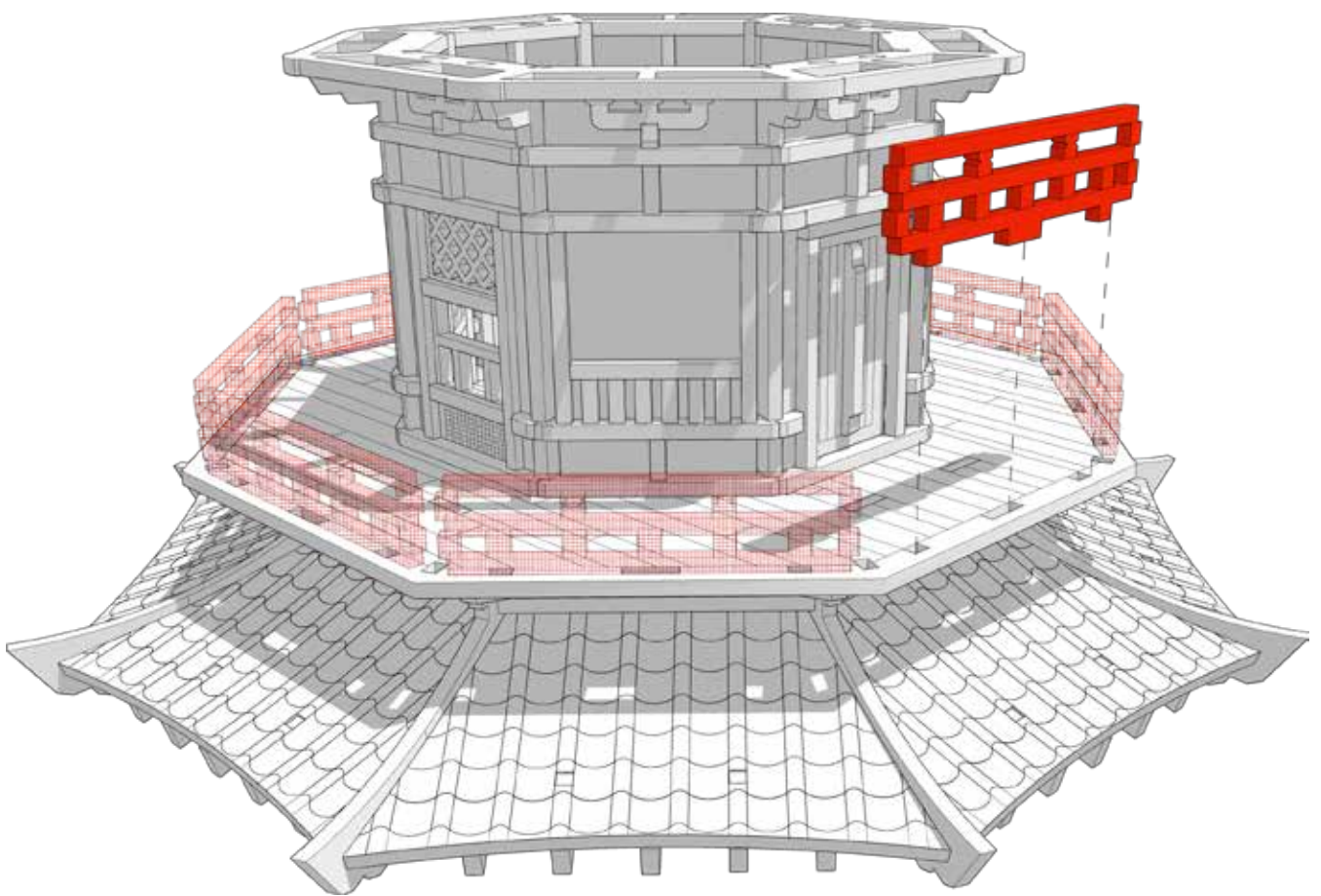



TABLETOP SCENICS

TTSCW-EES-110
Toshi
Hakkei-tō Pagoda

162

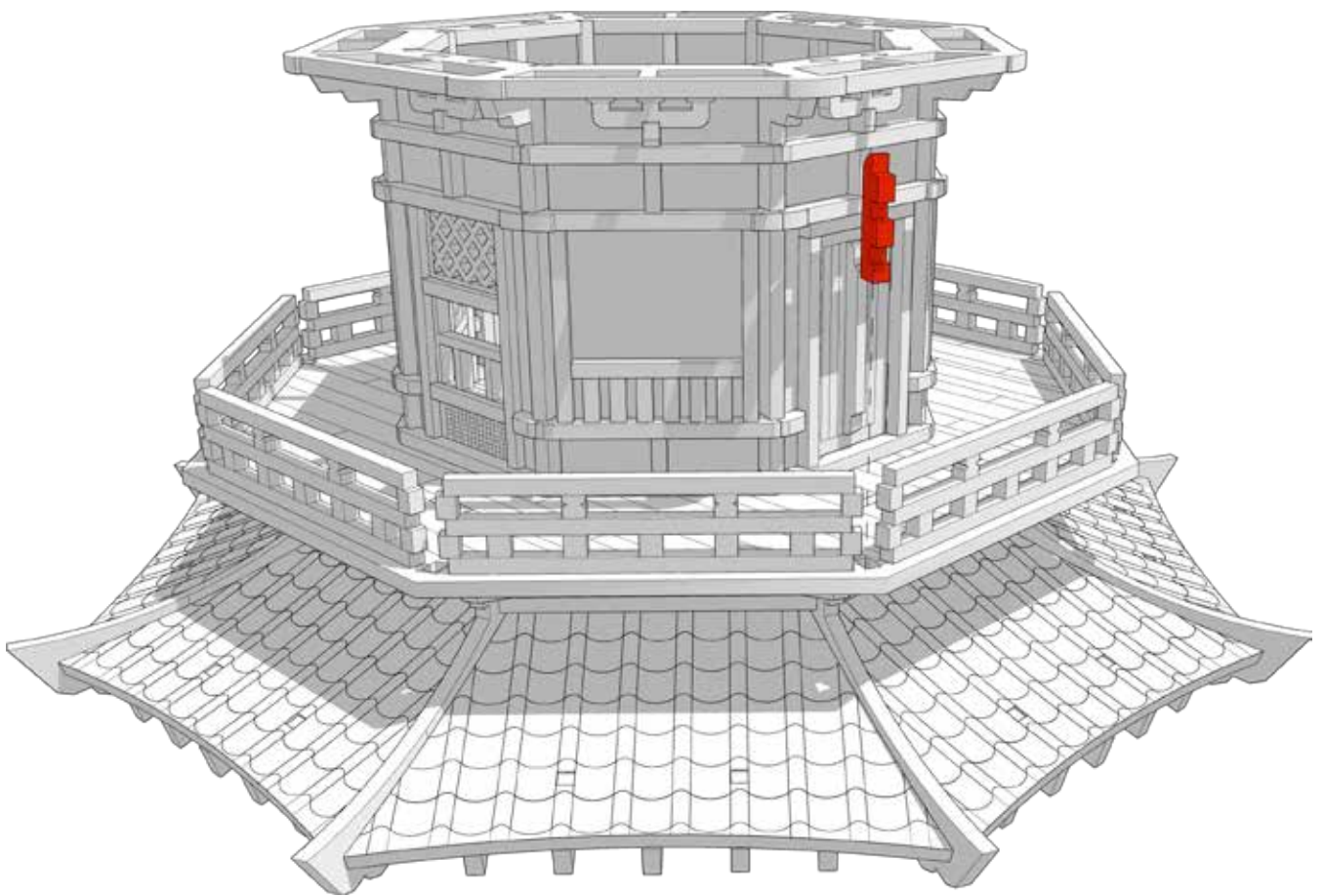



TABLETOP SCENICS

TTSCW-EES-110
Toshi
Hakkei-tō Pagoda

163

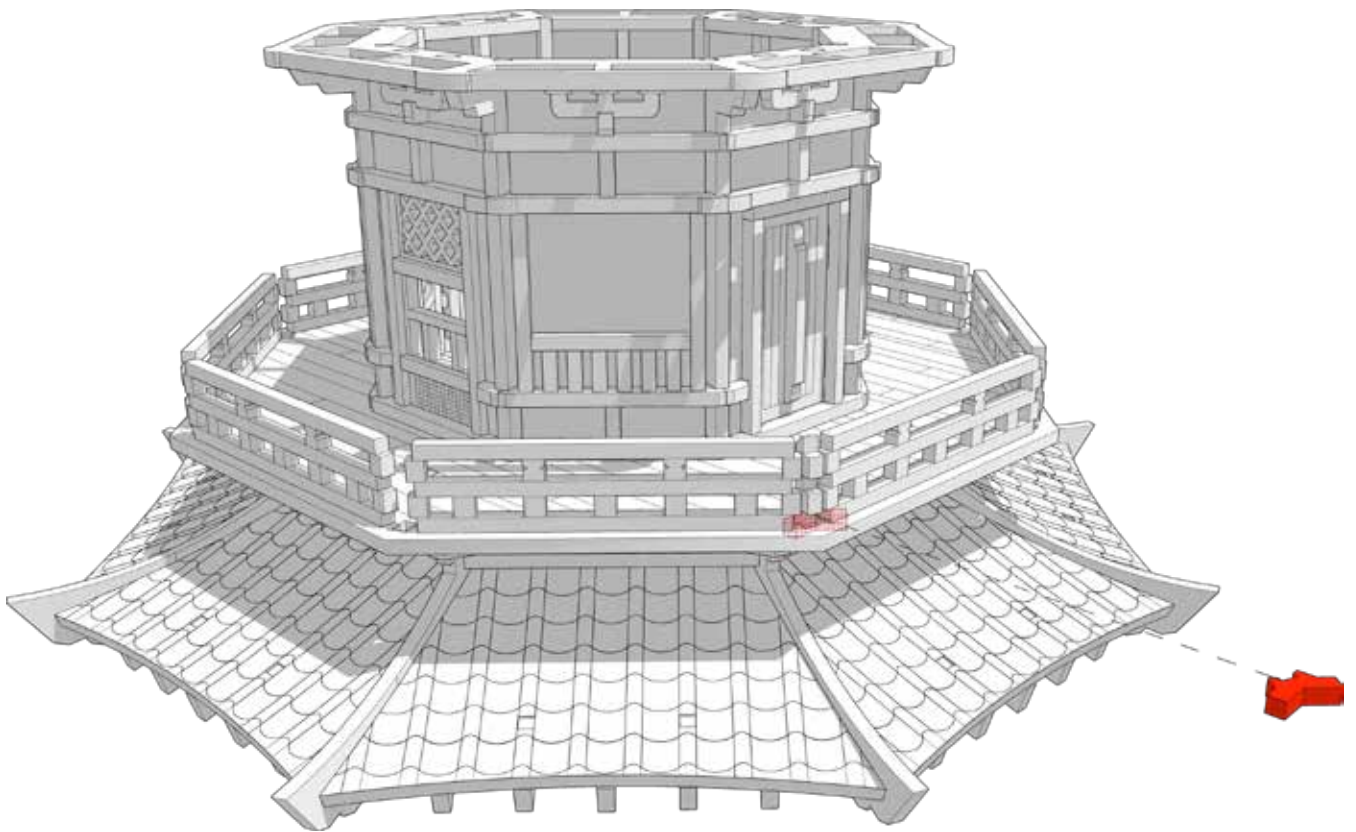



TABLETOP SCENICS

TTSCW-EES-110
Toshi
Hakkei-tō Pagoda

164

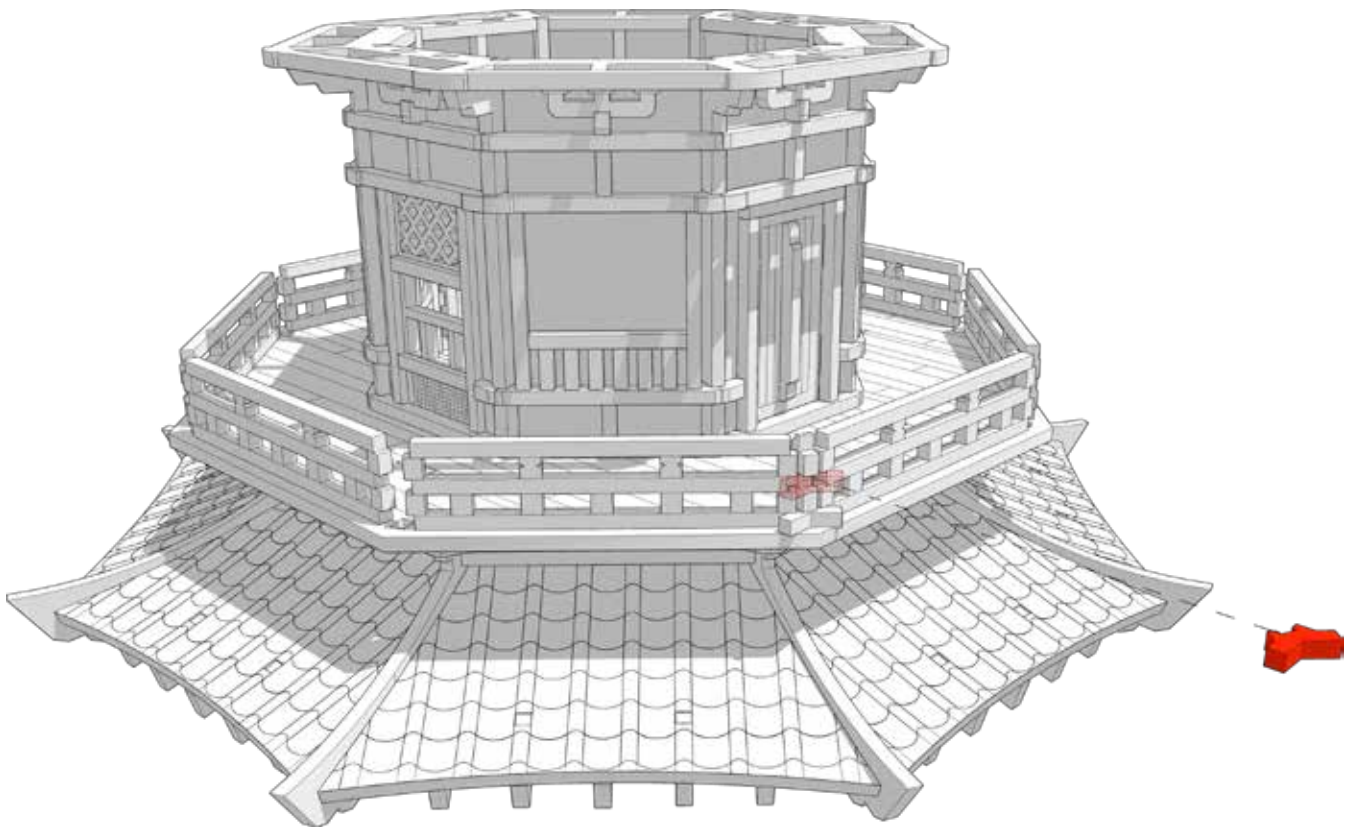



TABLETOP SCENICS

TTSCW-EES-110
Toshi
Hakkei-tō Pagoda

165

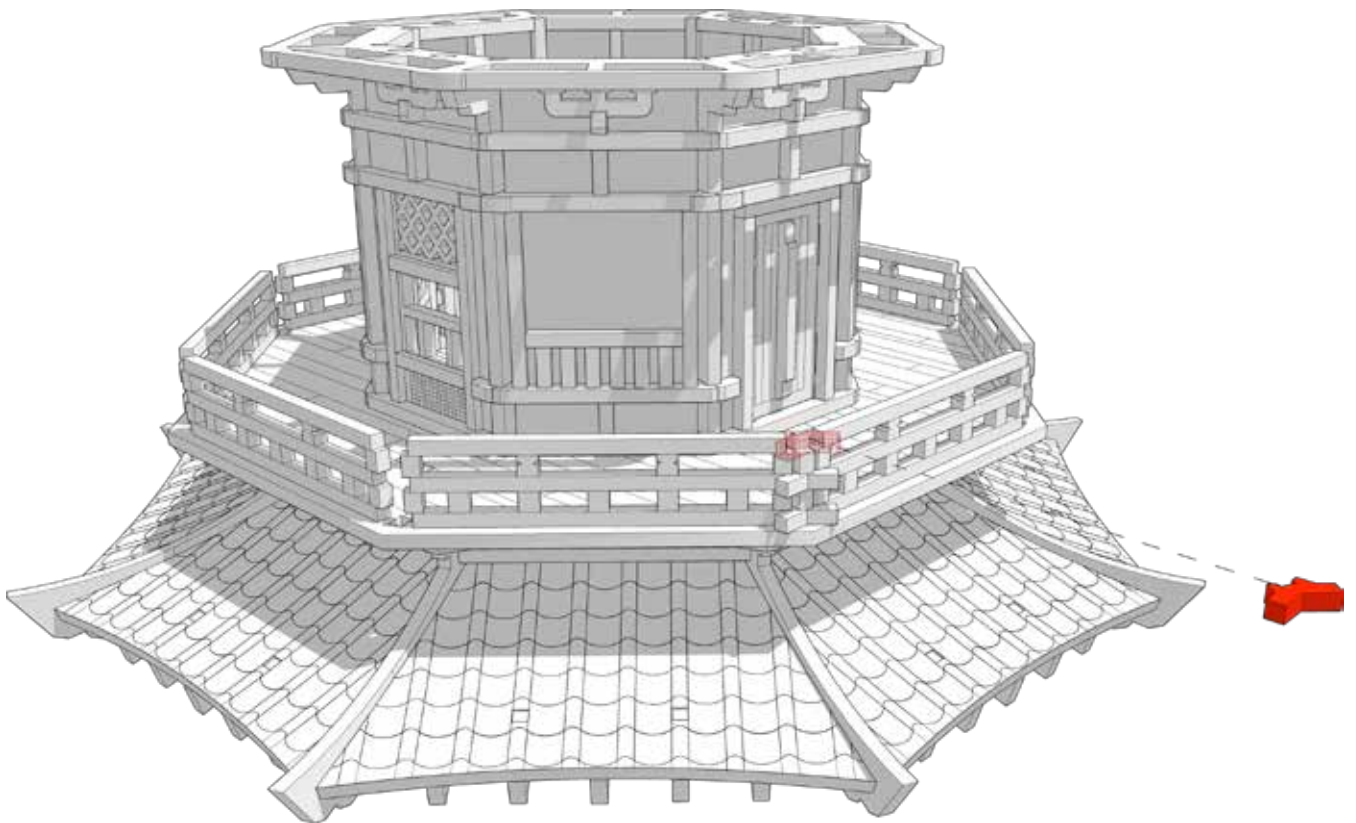



166

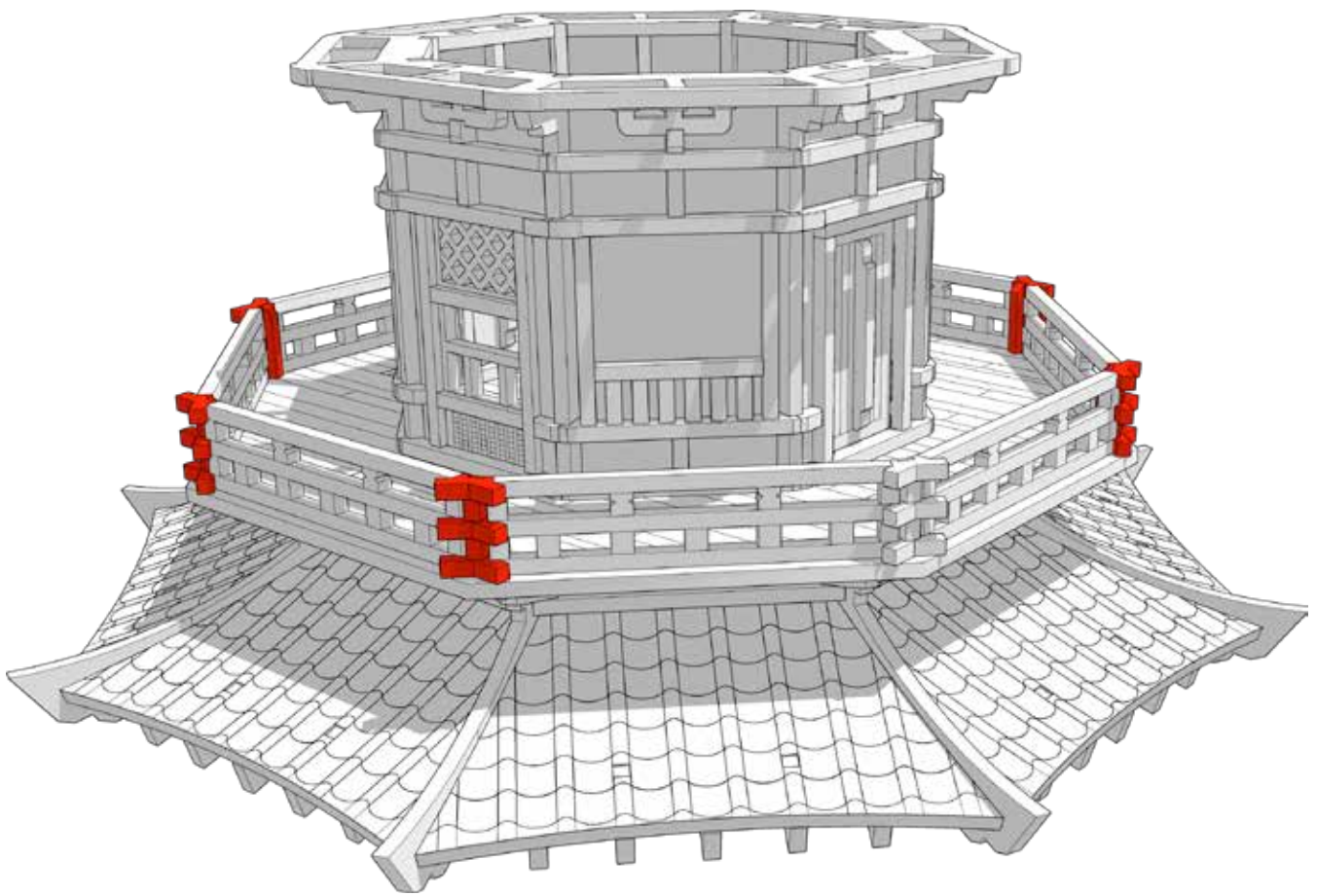

Repeat steps 150-153 for the rest
of the fencing



TABLETOP SCENICS

167

TTSCW-EES-110
Toshi
Hakkei-tō Pagoda

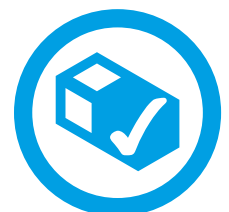
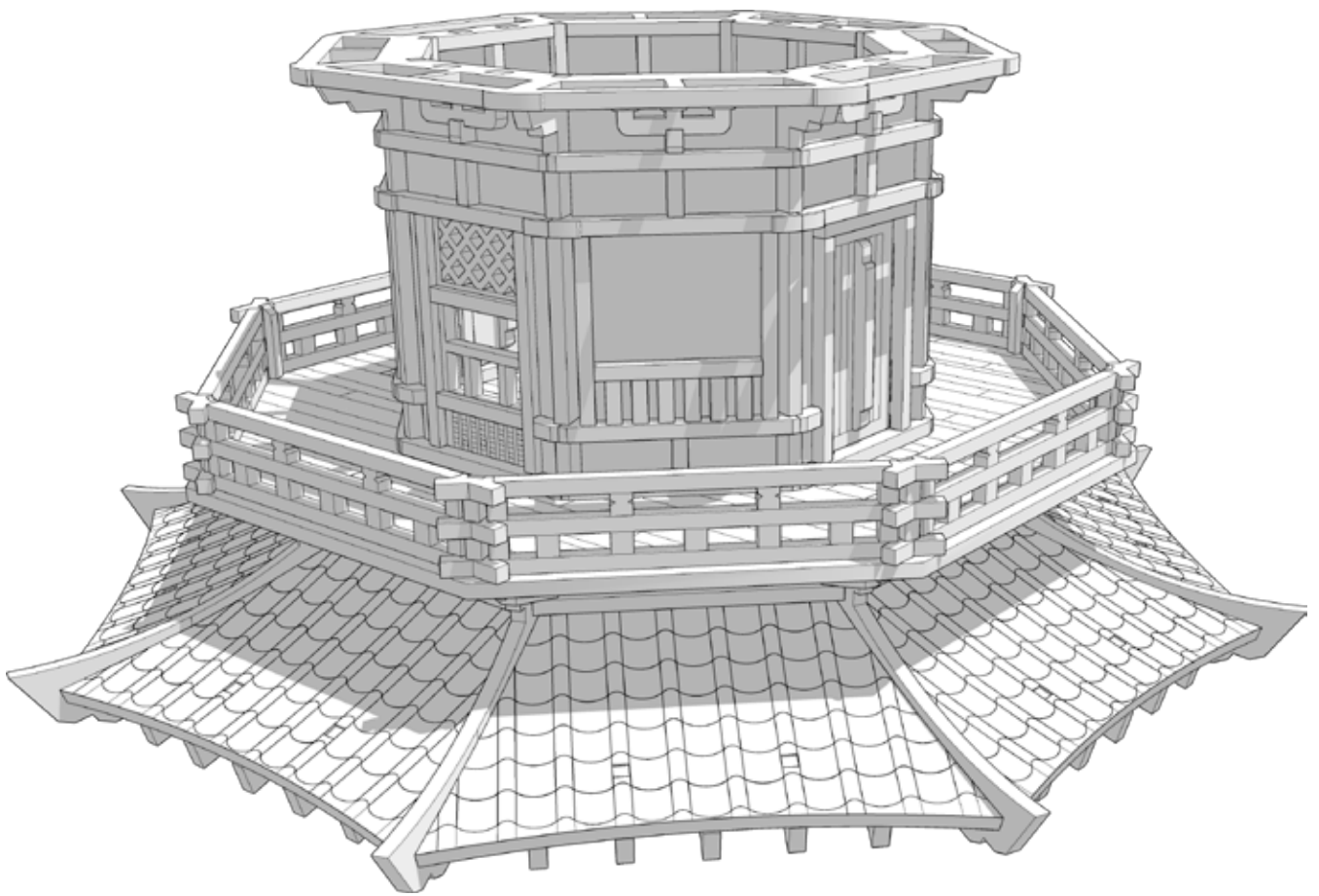

 TTCOMBAT



TABLETOP SCENICS

168

TTSCW-EES-110
Toshi
Hakkei-tō Pagoda

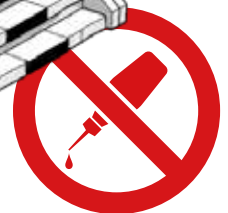
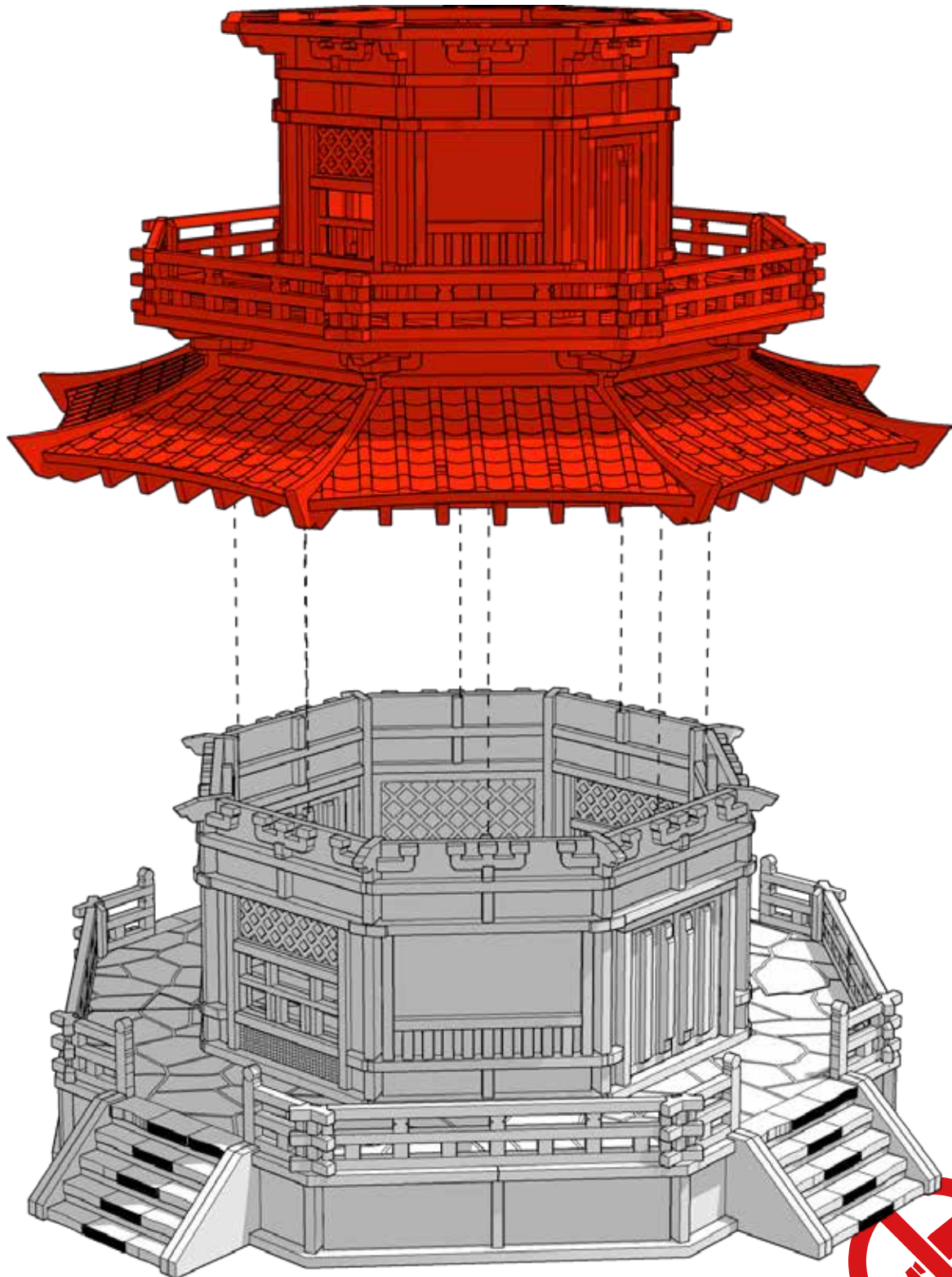

Do not glue into place. Order of levels is optional and can be added too with extension kits

 **TTCOMBAT**



TABLETOP SCENICS

169

TTSCW-EES-110
Toshi
Hakkei-tō Pagoda

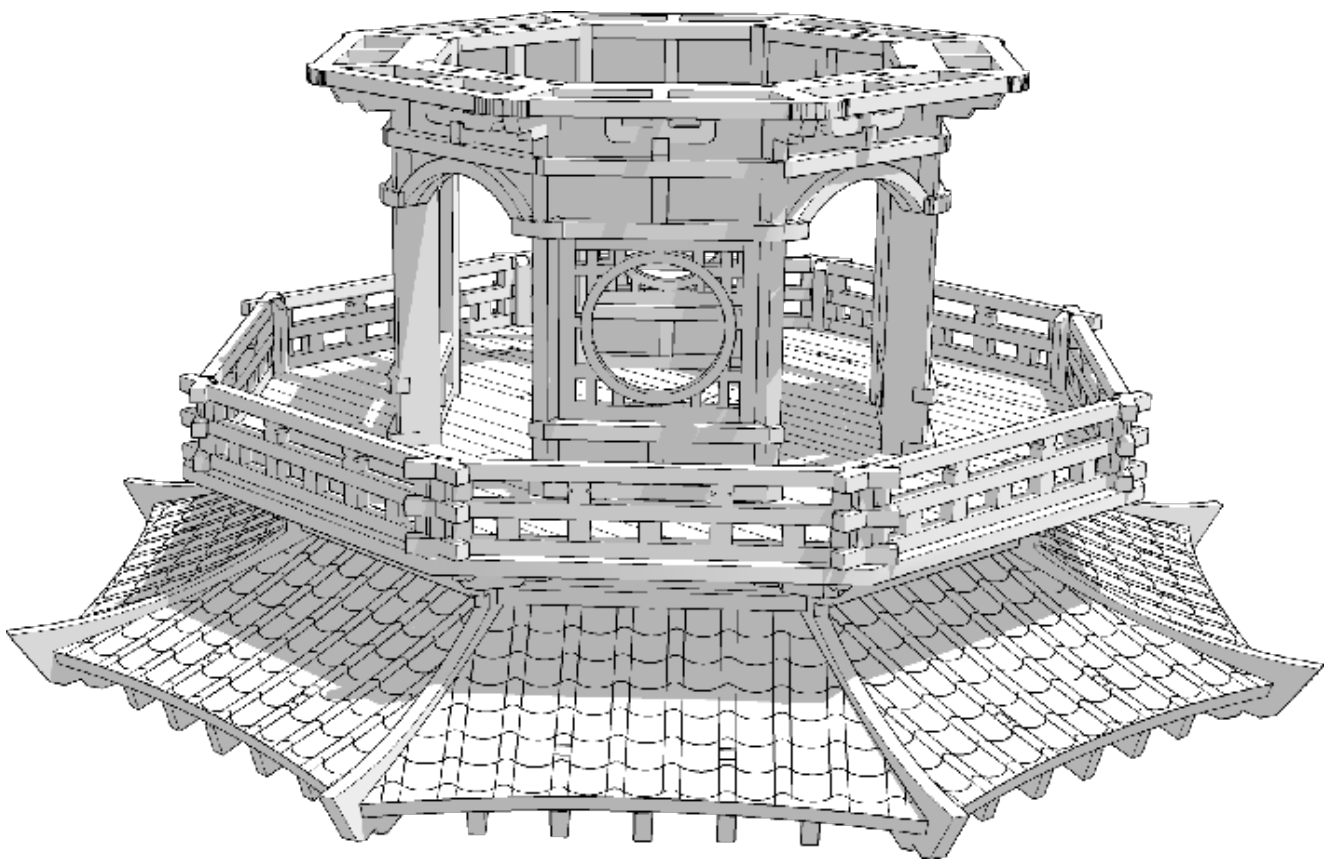

Open Extension





TABLETOP SCENICS

170

TTSCW-EES-110
Toshi
Hakkei-tō Pagoda

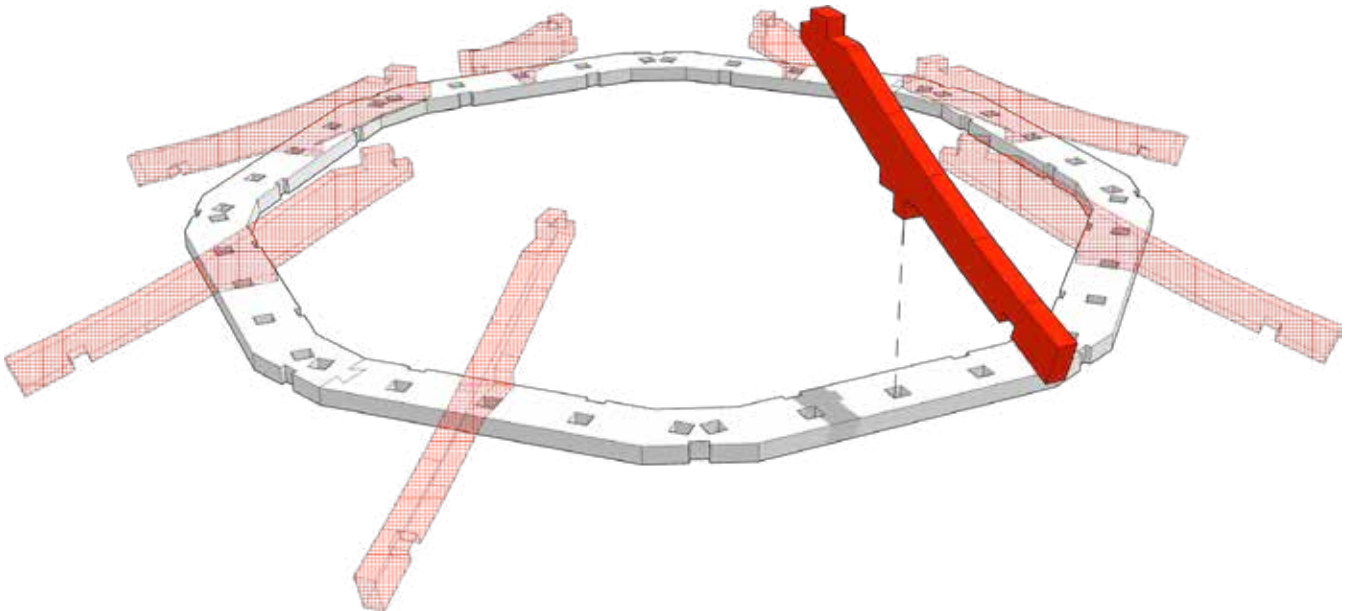

PVA recommended for this stage of the roof to allow for some movement during construction





TABLETOP SCENICS

171

TTSCW-EES-110
Toshi
Hakkei-tō Pagoda

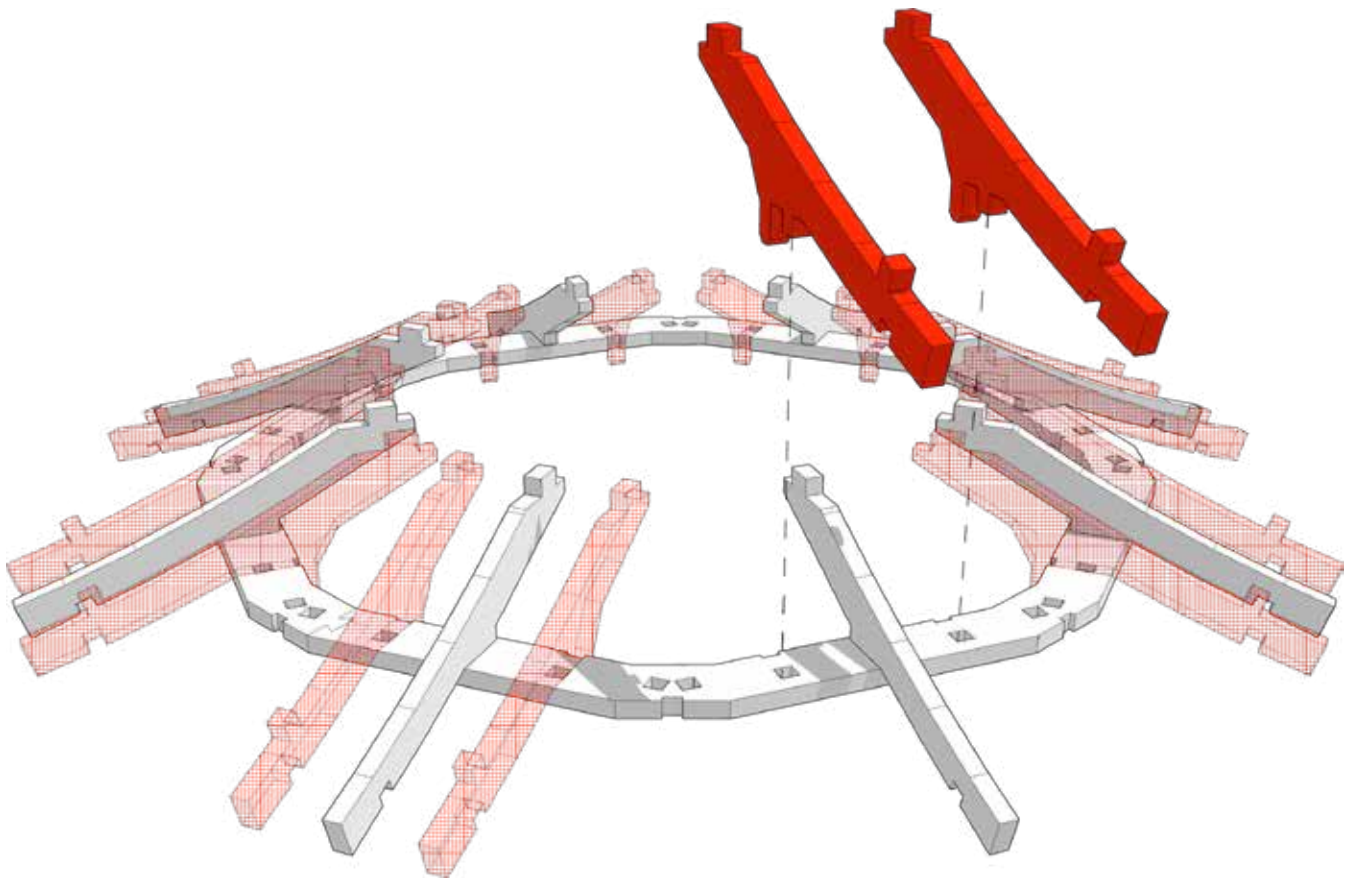



TABLETOP SCENICS

172

TTSCW-EES-110
Toshi
Hakkei-tō Pagoda

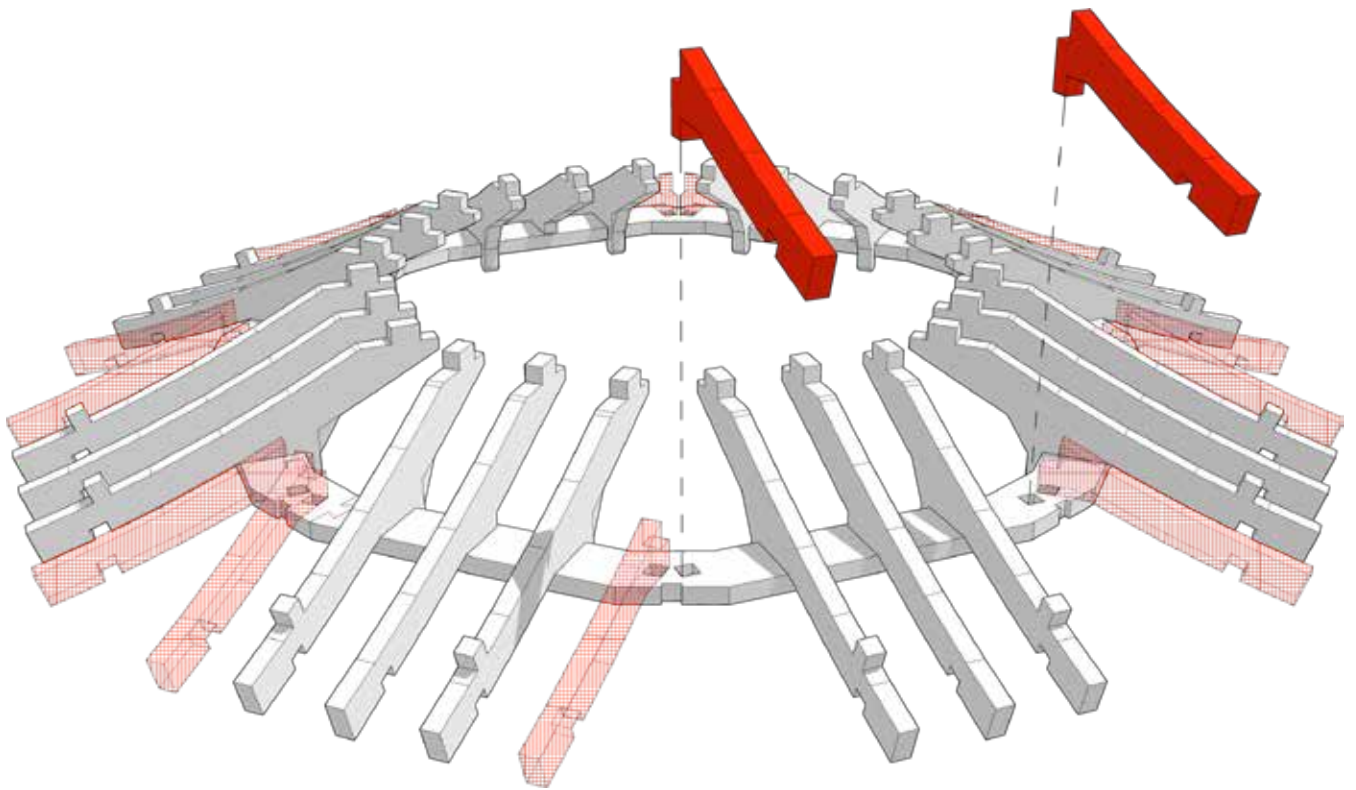



TABLETOP SCENICS

TTSCW-EES-110
Toshi
Hakkei-tō Pagoda

173

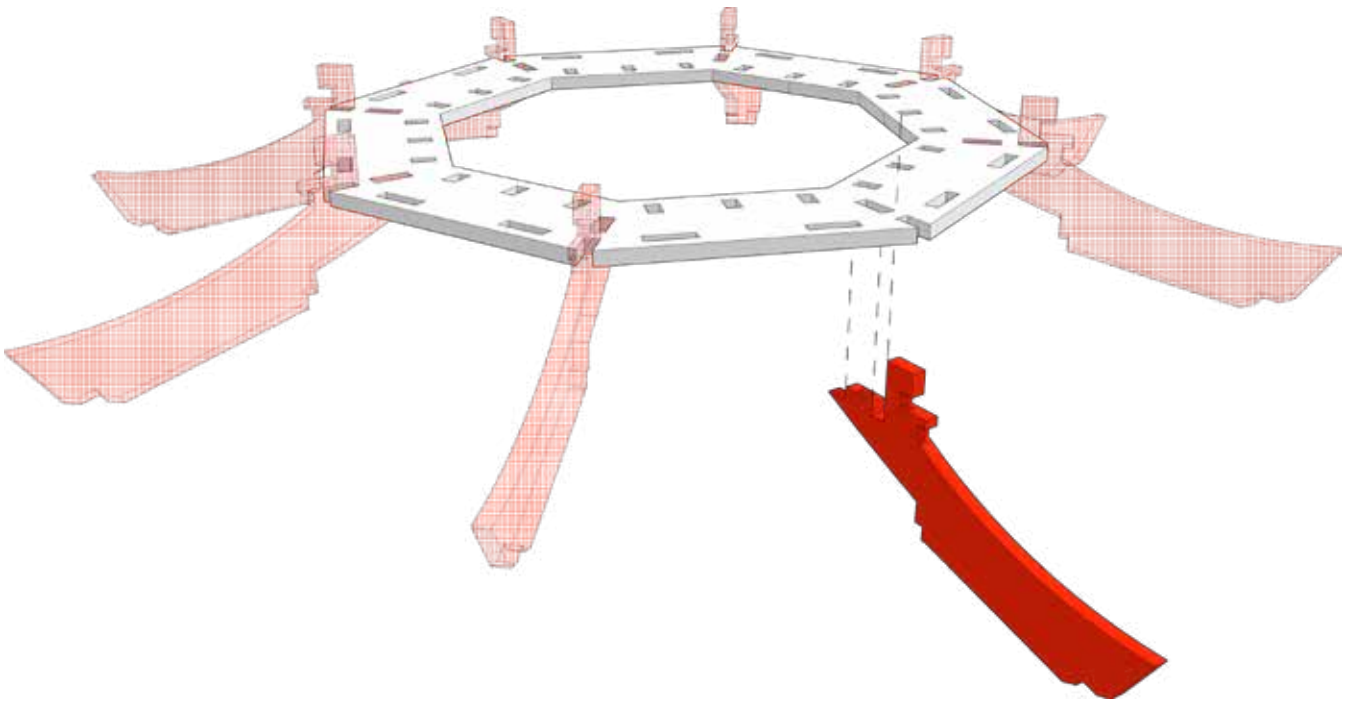



TABLETOP SCENICS

174

TTSCW-EES-110
Toshi
Hakkei-tō Pagoda

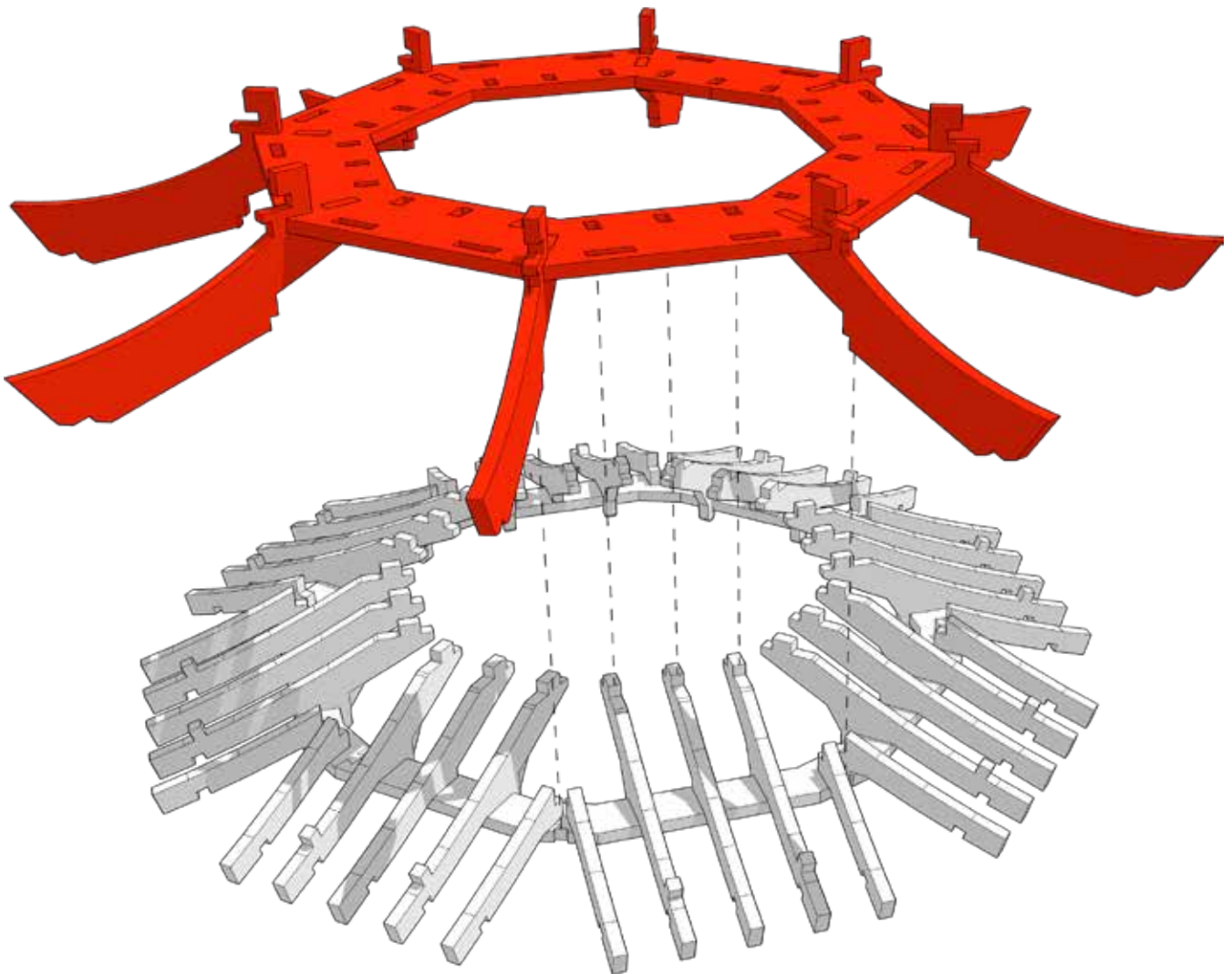

It is likely parts will pop out as you progressively slot this on. Be sure to check all parts are fully in place before glue dries.





TABLETOP SCENICS

175

TTSCW-EES-110
Toshi
Hakkei-tō Pagoda

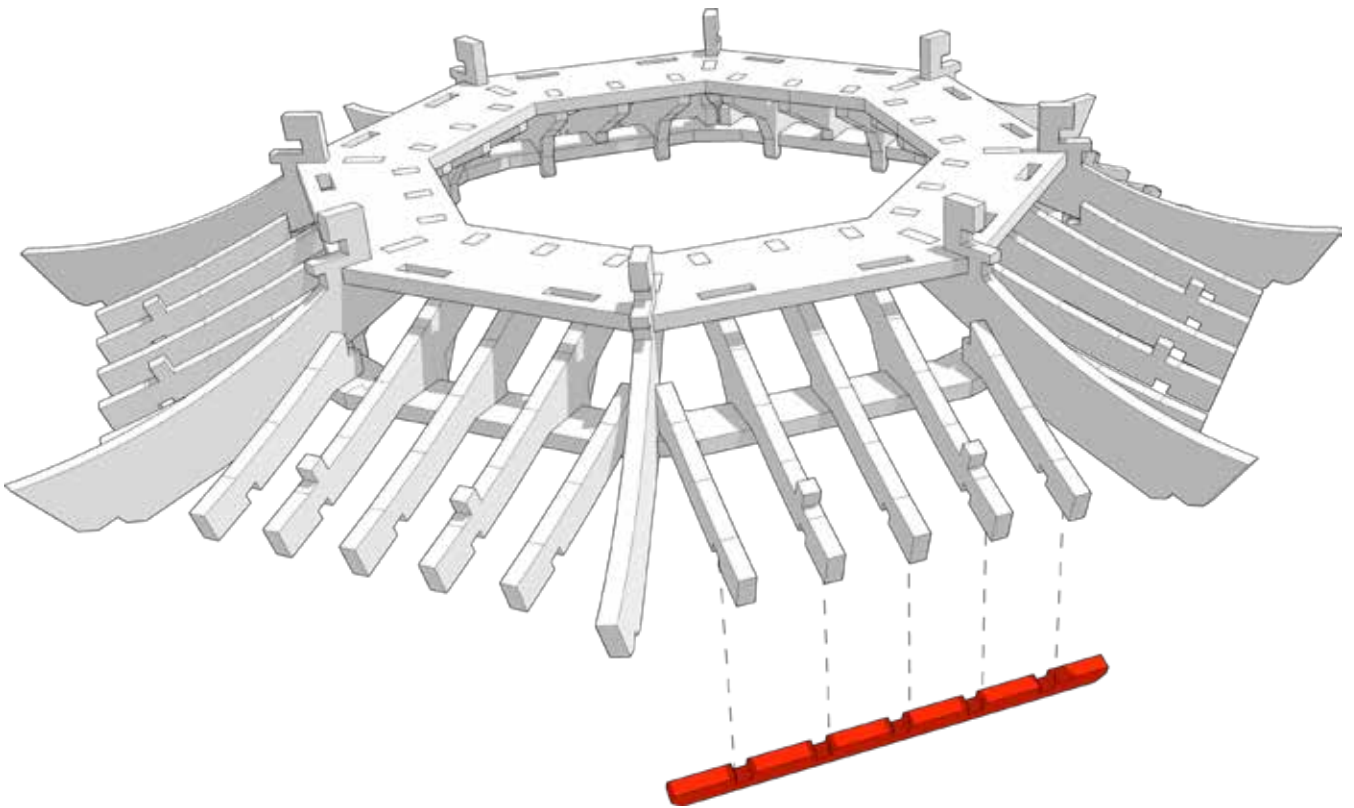



TABLETOP SCENICS

176

TTSCW-EES-110
Toshi
Hakkei-tō Pagoda

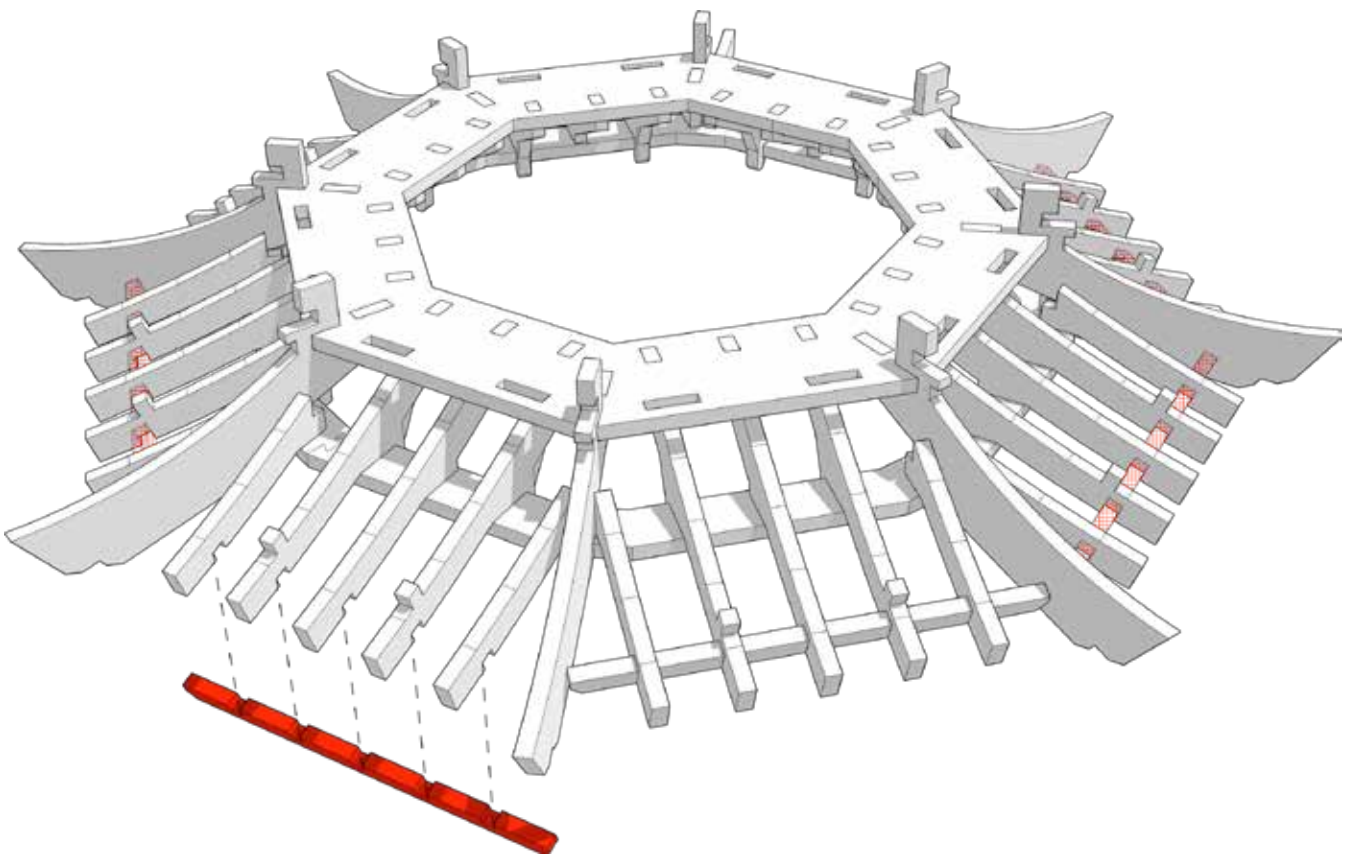

Repeat step for all remaining sides



TABLETOP SCENICS

TTSCW-EES-110
Toshi
Hakkei-tō Pagoda

177

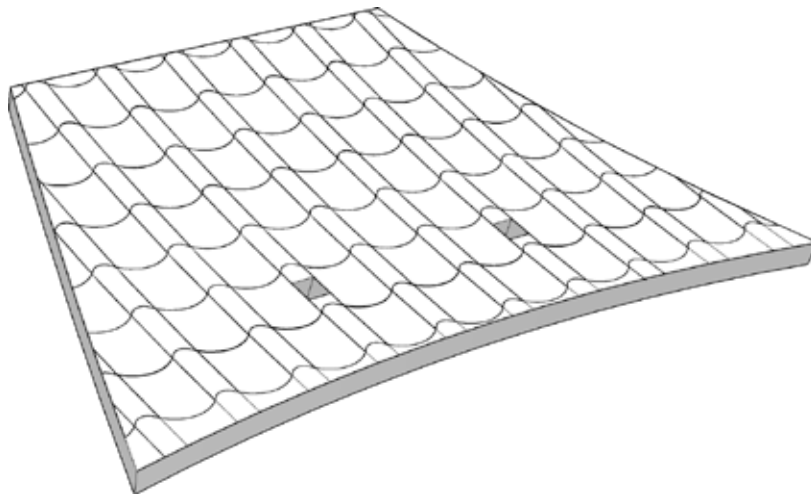

FRAGILE

Over bending will cause this to break

Do not bend freely



TABLETOP SCENICS

178

TTSCW-EES-110
Toshi
Hakkei-tō Pagoda

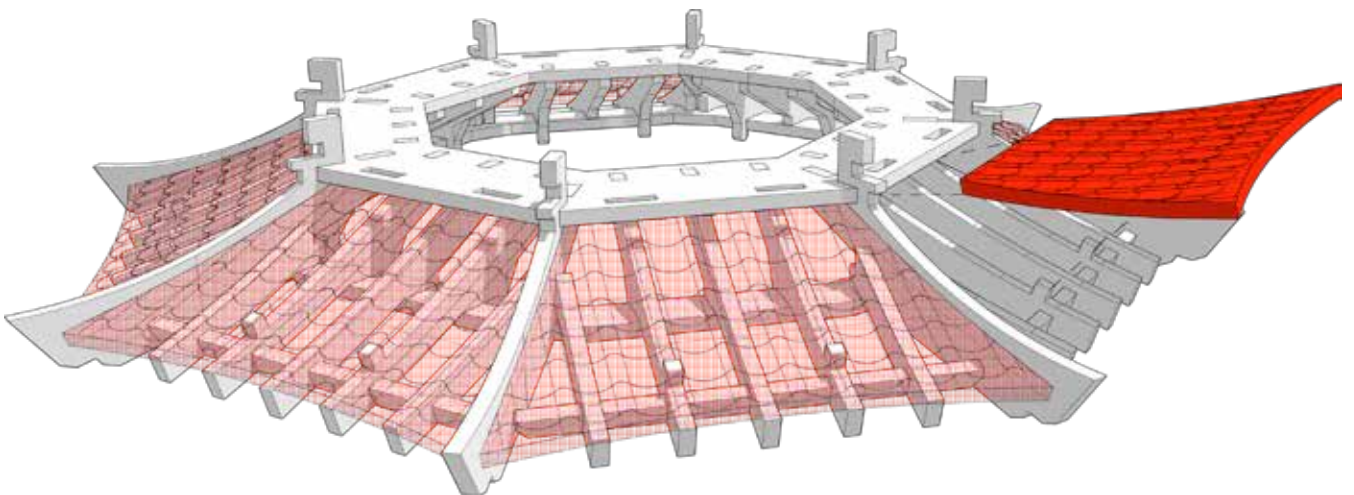

Roof sits under the larger hexagon part. Slot into place and align the tabs and push down. Using superglue or a fast drying glue is recommended. Repeat around the roof.



TABLETOP SCENICS

179

TTSCW-EES-110
Toshi
Hakkei-tō Pagoda

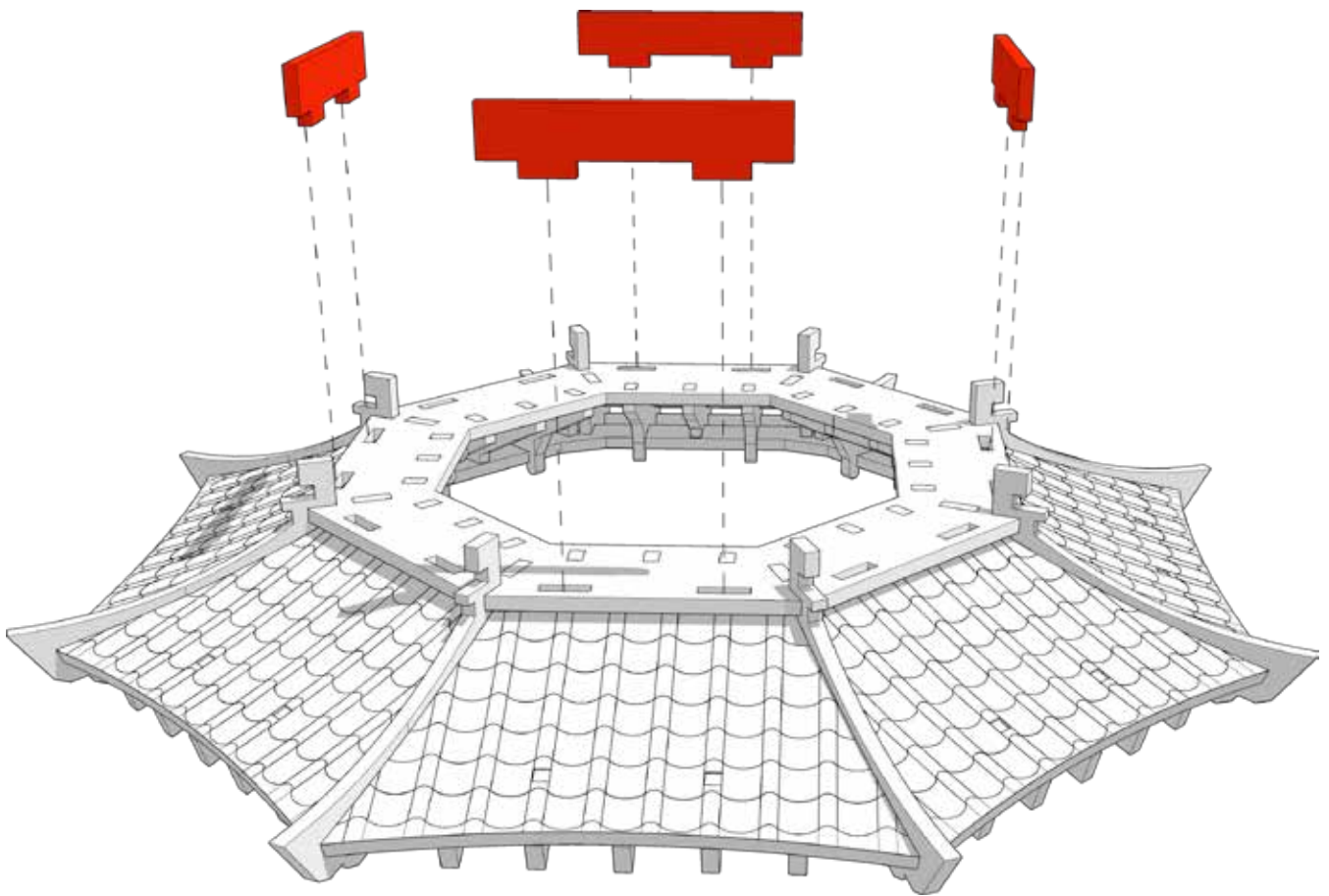



TABLETOP SCENICS

180

TTSCW-EES-110
Toshi
Hakkei-tō Pagoda

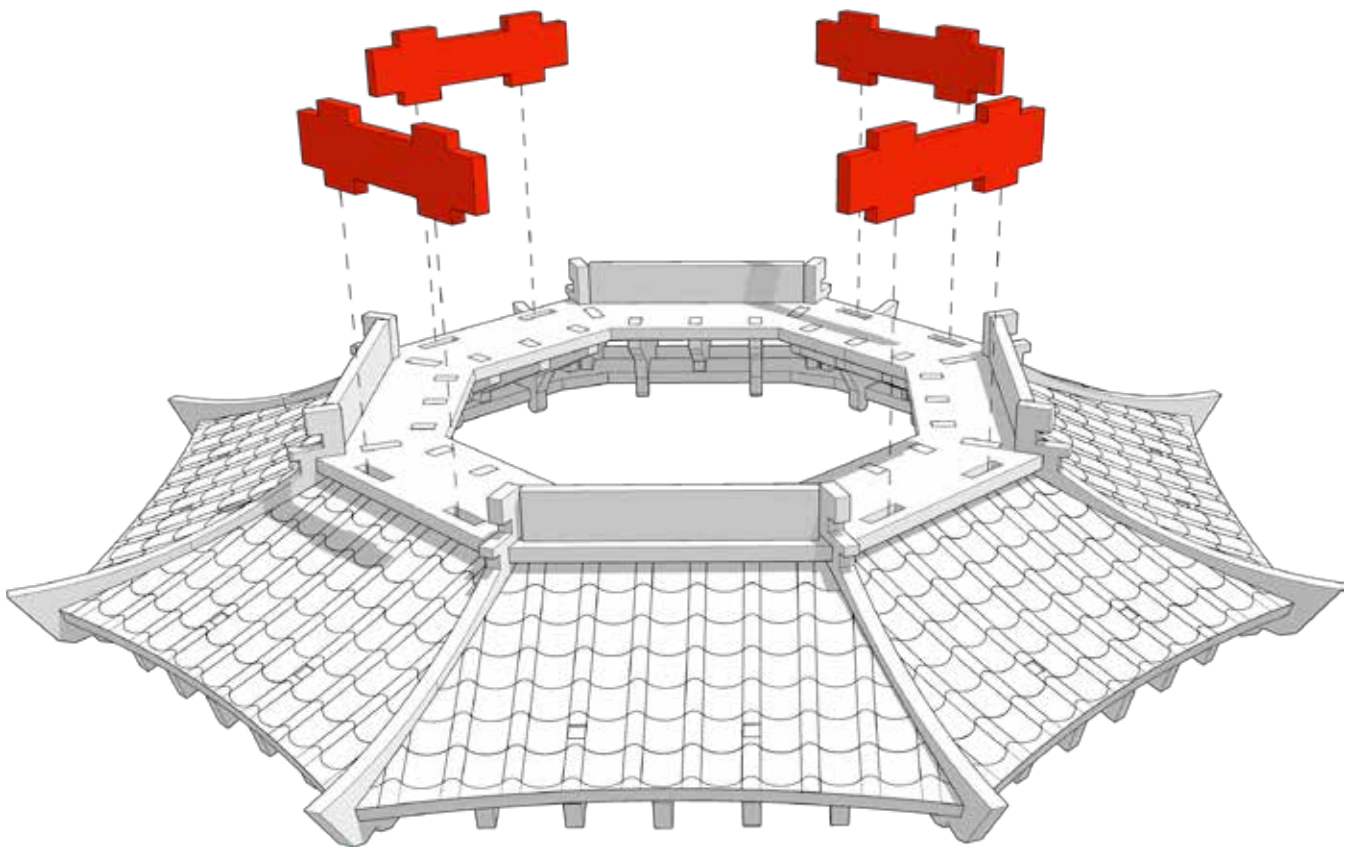



TABLETOP SCENICS

TTSCW-EES-110
Toshi
Hakkei-tō Pagoda

181

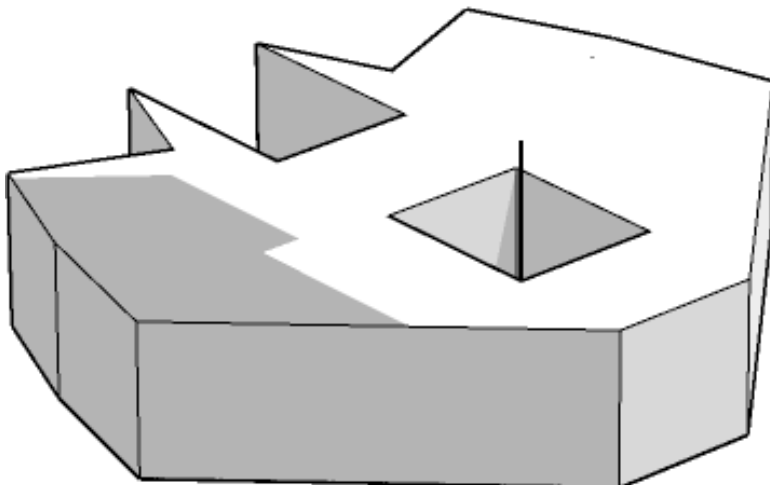
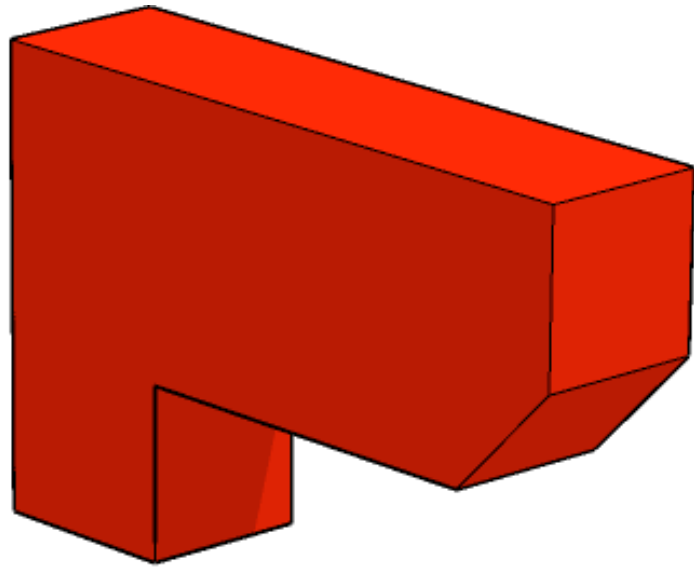



TABLETOP SCENICS

TTSCW-EES-110
Toshi
Hakkei-tō Pagoda

182

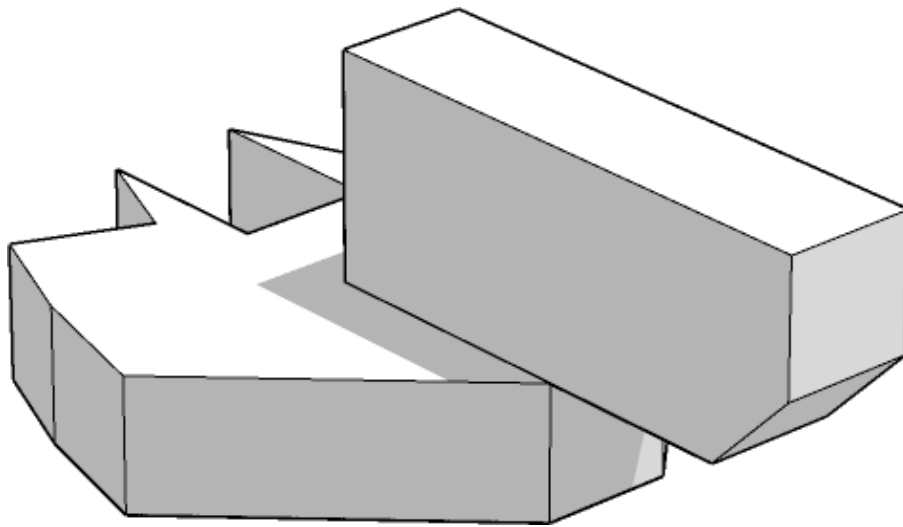



TABLETOP SCENICS

TTSCW-EES-110
Toshi
Hakkei-tō Pagoda

183

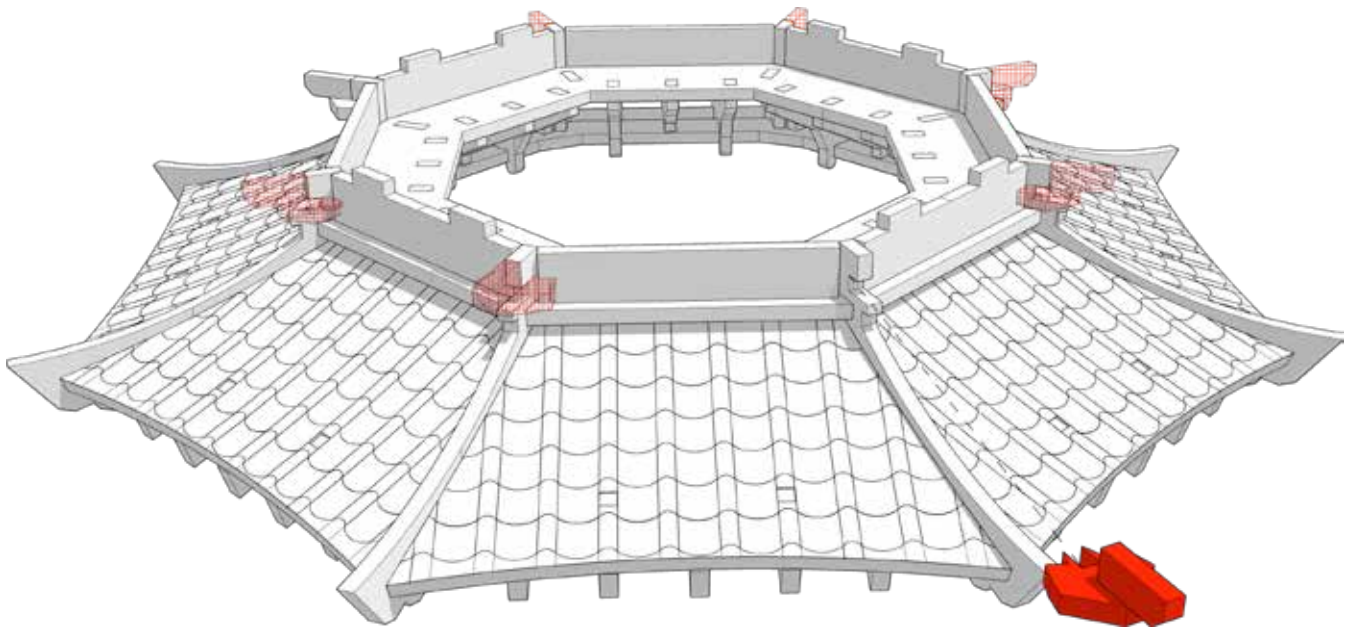

Repeat the step around the roof

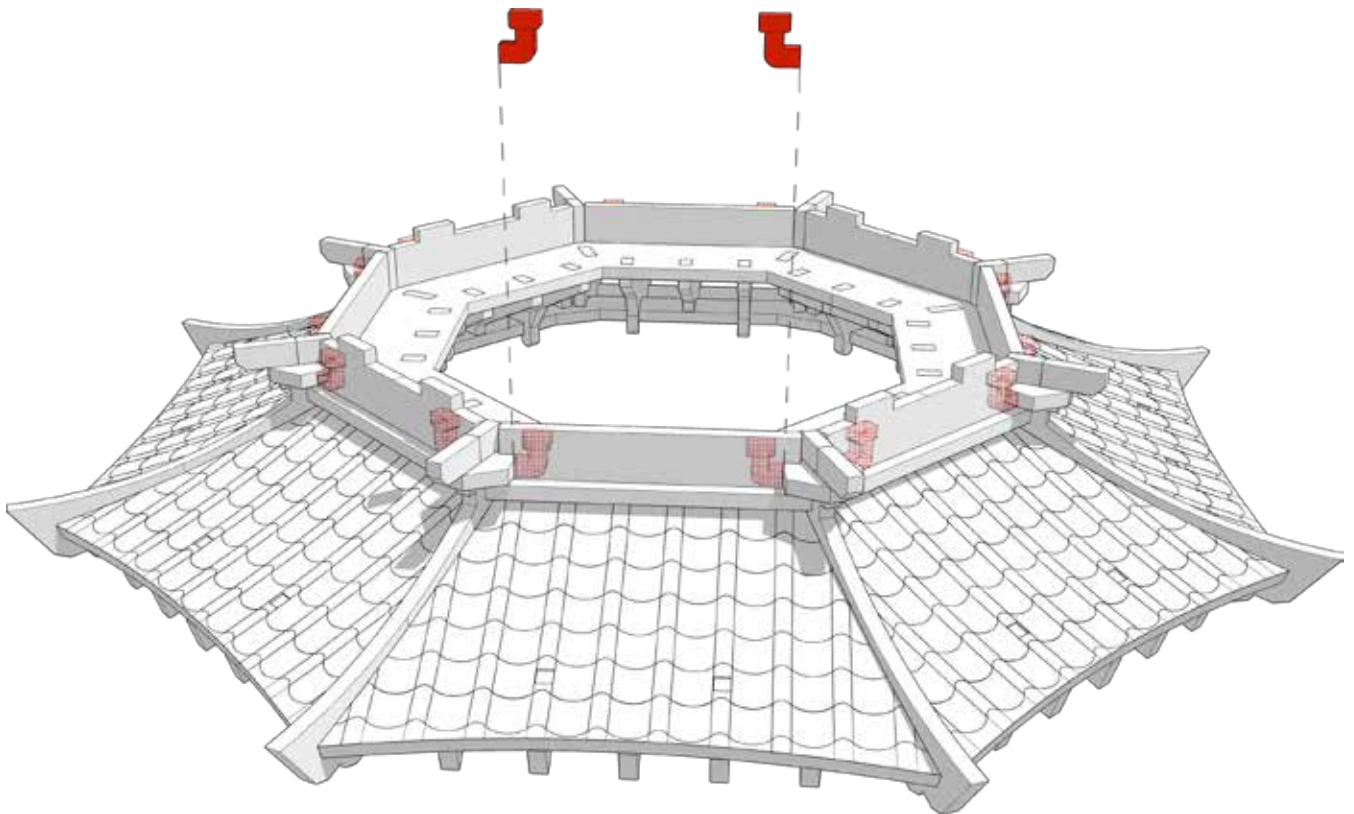

Repeat step around the roof



TABLETOP SCENICS

TTSCW-EES-110
Toshi
Hakkei-tō Pagoda

185

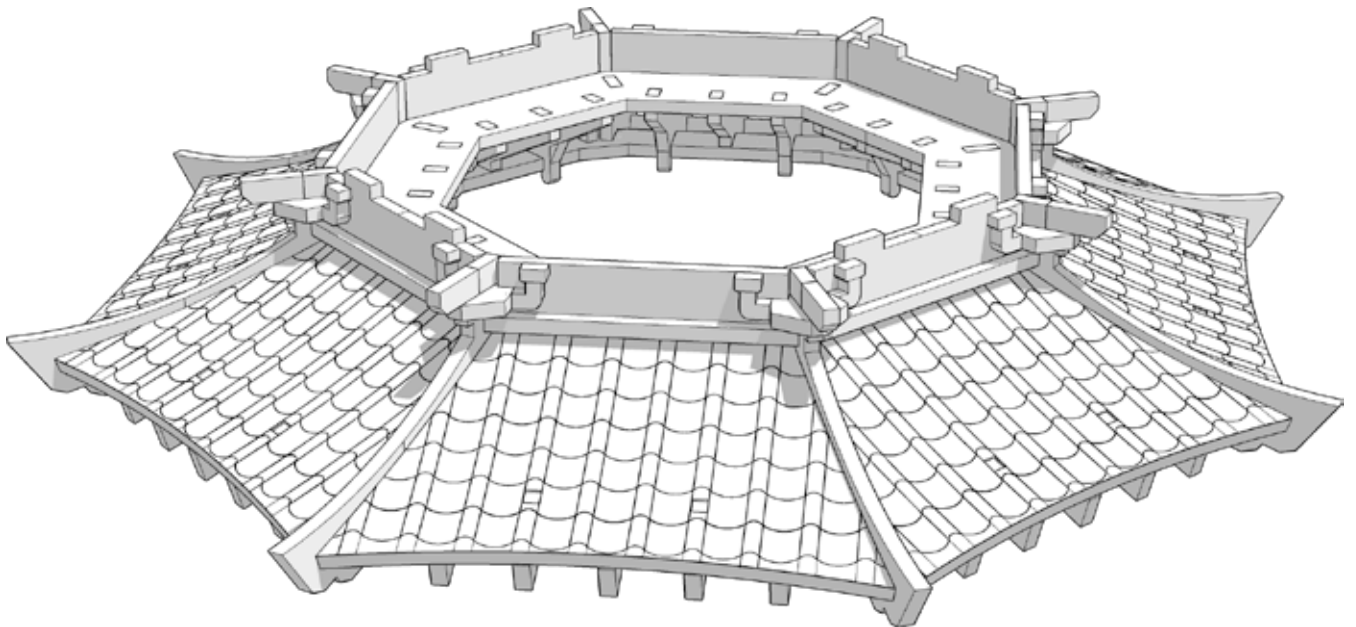



TABLETOP SCENICS

186

TTSCW-EES-110
Toshi
Hakkei-tō Pagoda

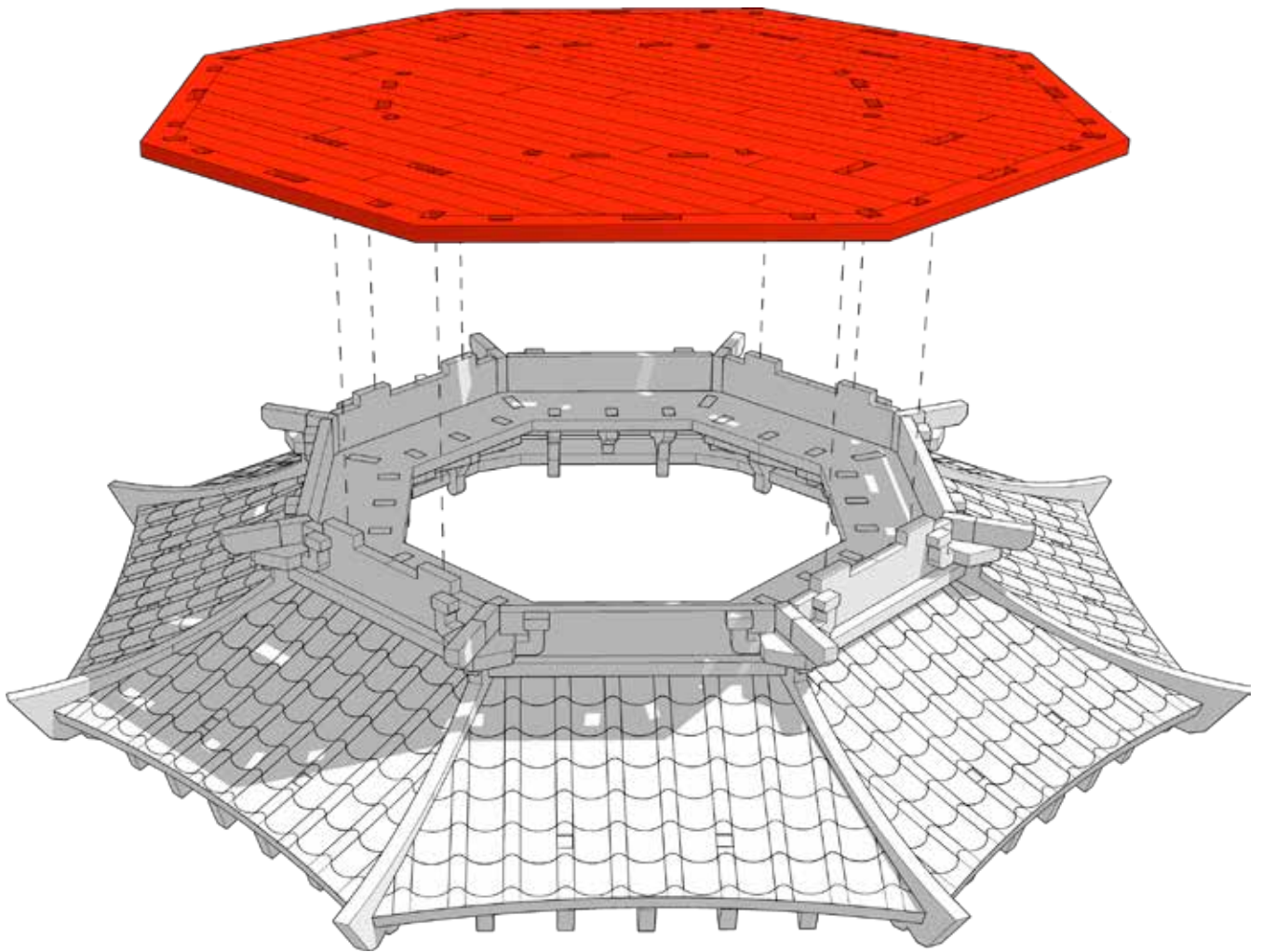



TABLETOP SCENICS

187

TTSCW-EES-110
Toshi
Hakkei-tō Pagoda

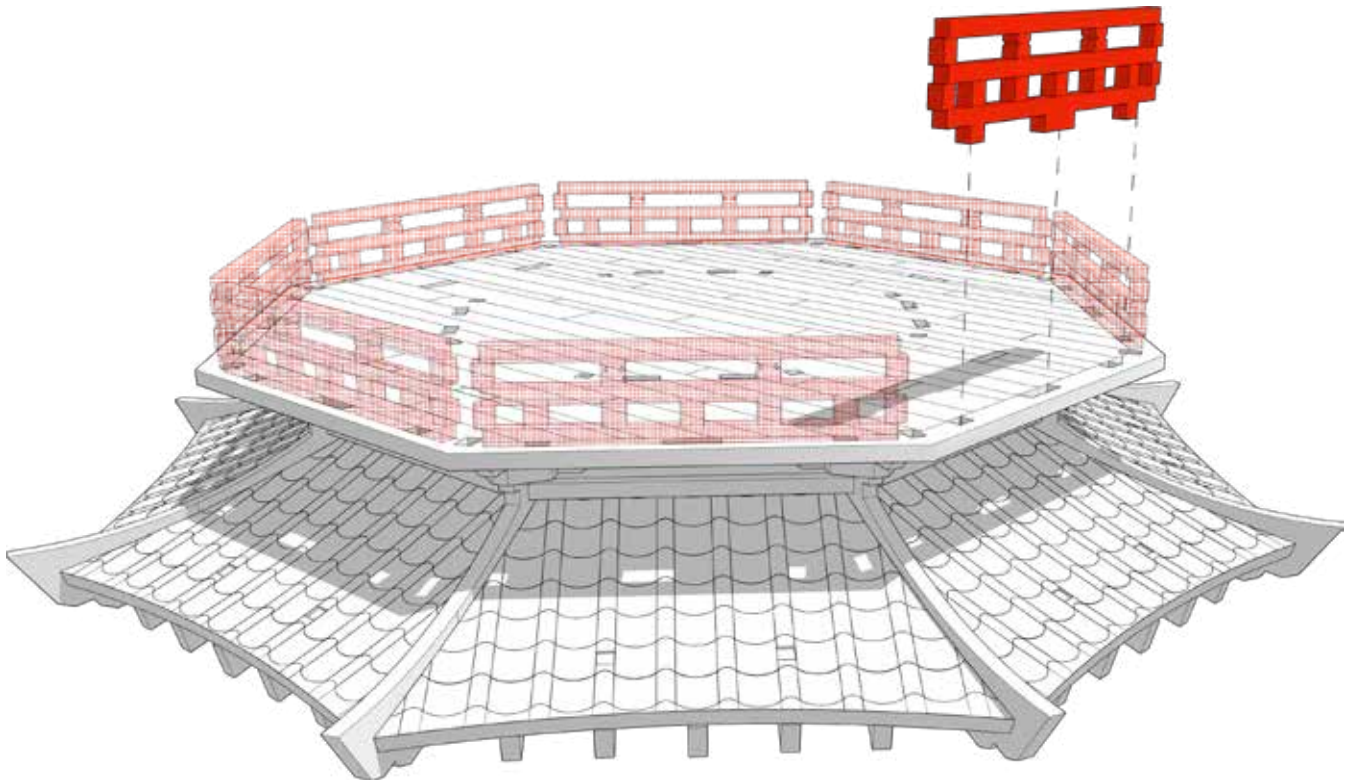



TABLETOP SCENICS

TTSCW-EES-110
Toshi
Hakkei-tō Pagoda

188

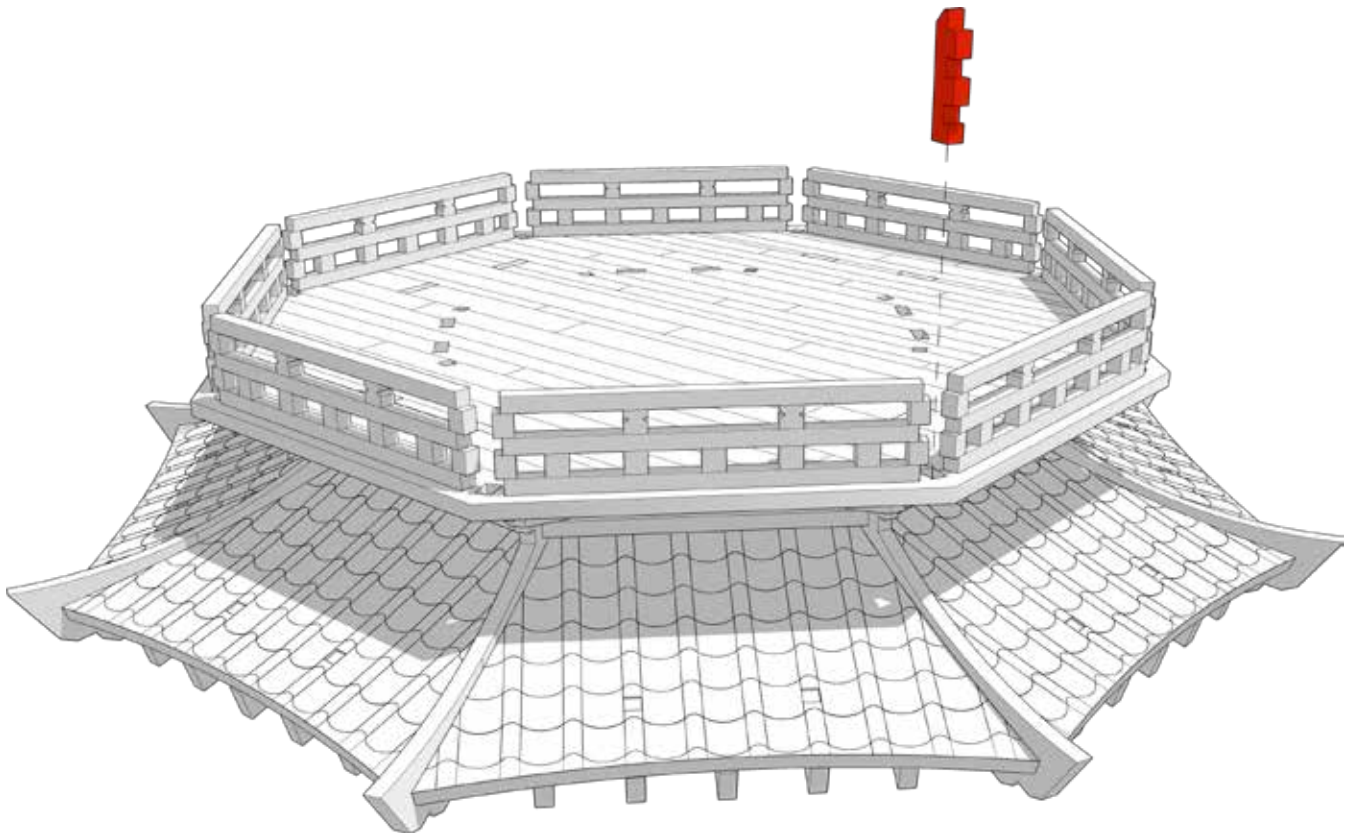



TABLETOP SCENICS

TTSCW-EES-110
Toshi
Hakkei-tō Pagoda

189

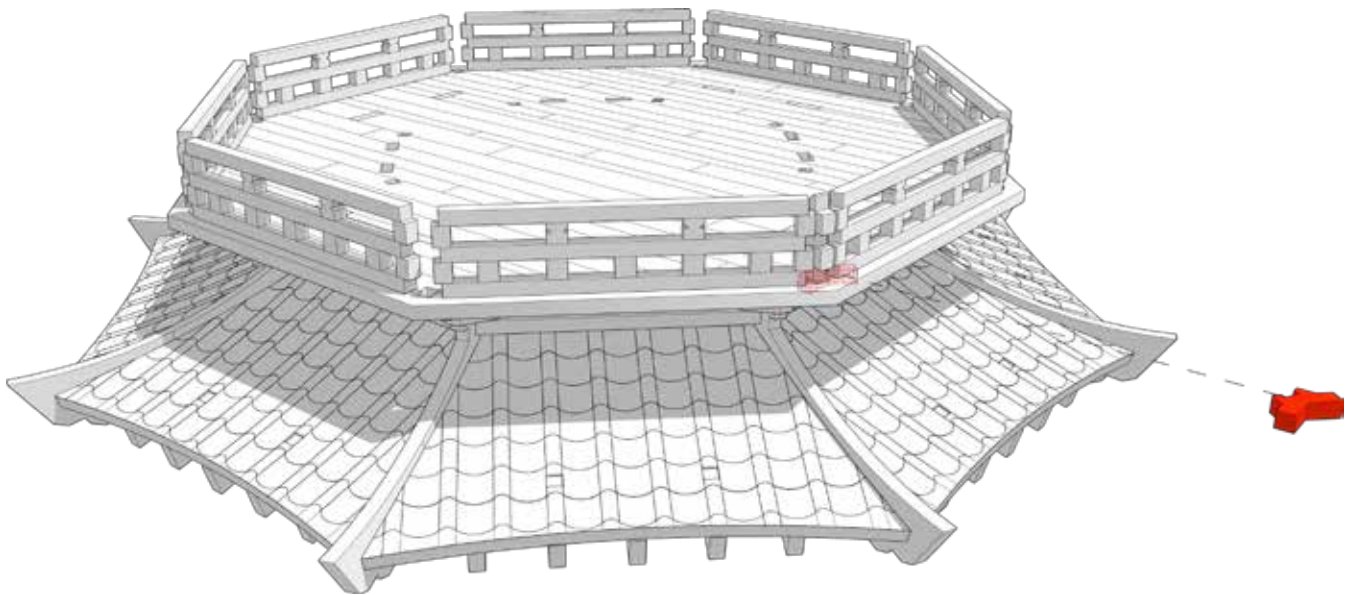



TABLETOP SCENICS

190

TTSCW-EES-110
Toshi
Hakkei-tō Pagoda

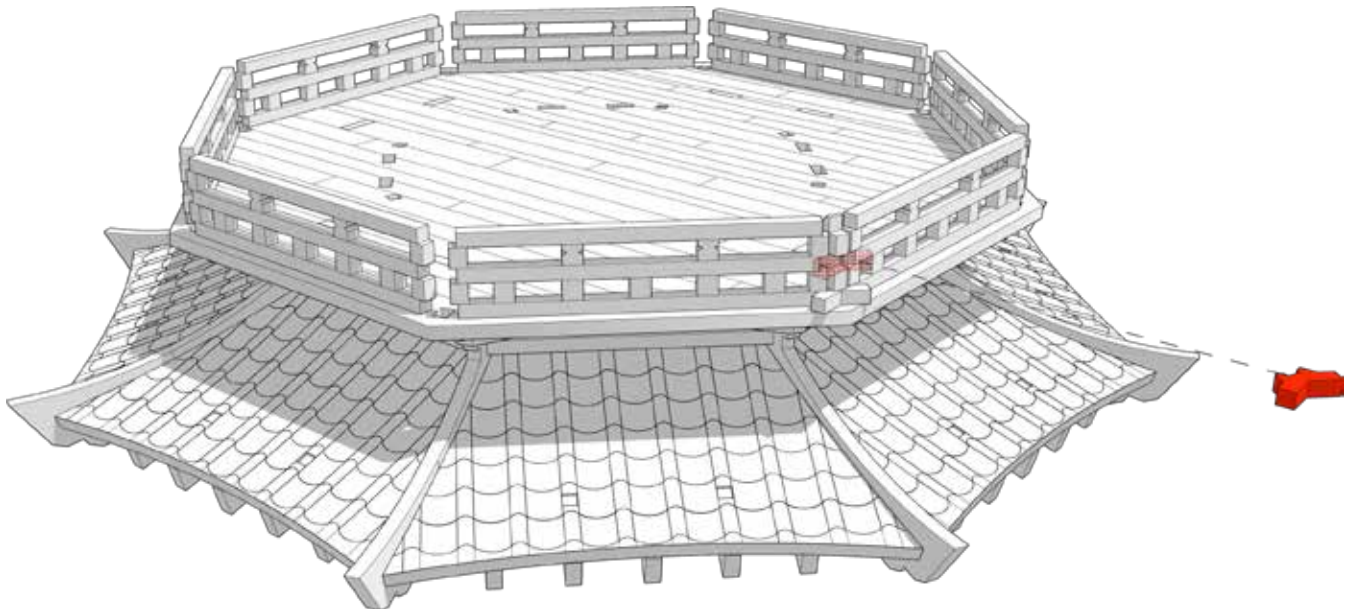



TABLETOP SCENICS

TTSCW-EES-110
Toshi
Hakkei-tō Pagoda

191

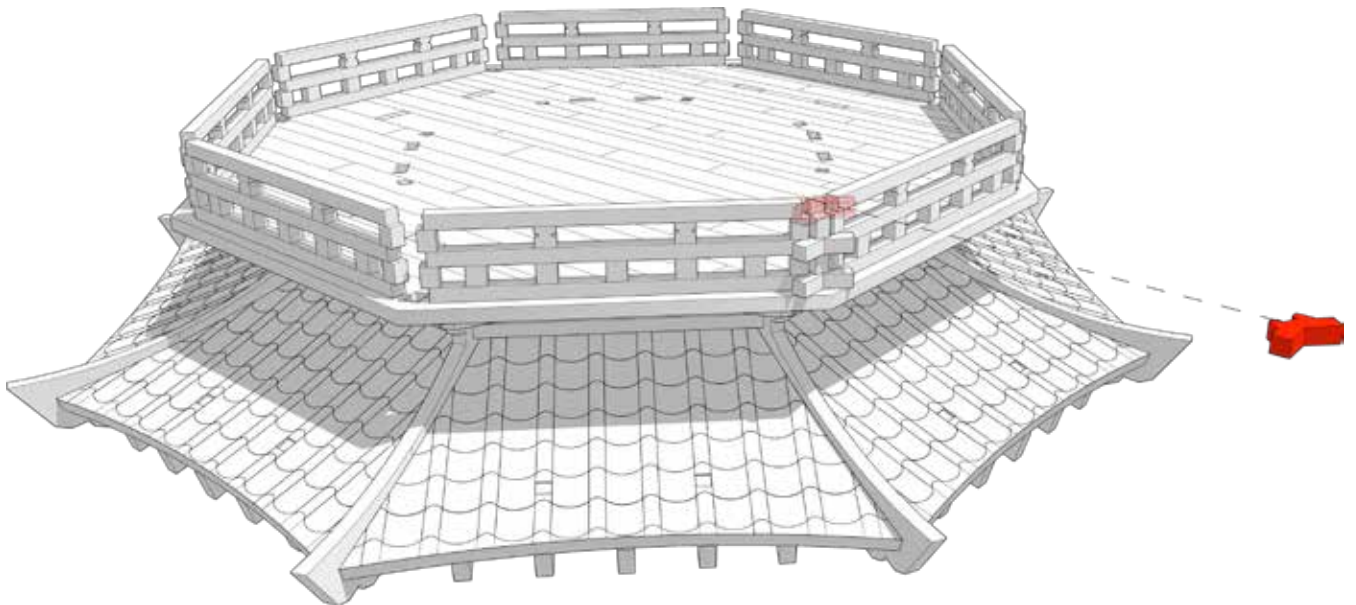



TABLETOP SCENICS

TTSCW-EES-110
Toshi
Hakkei-tō Pagoda

192

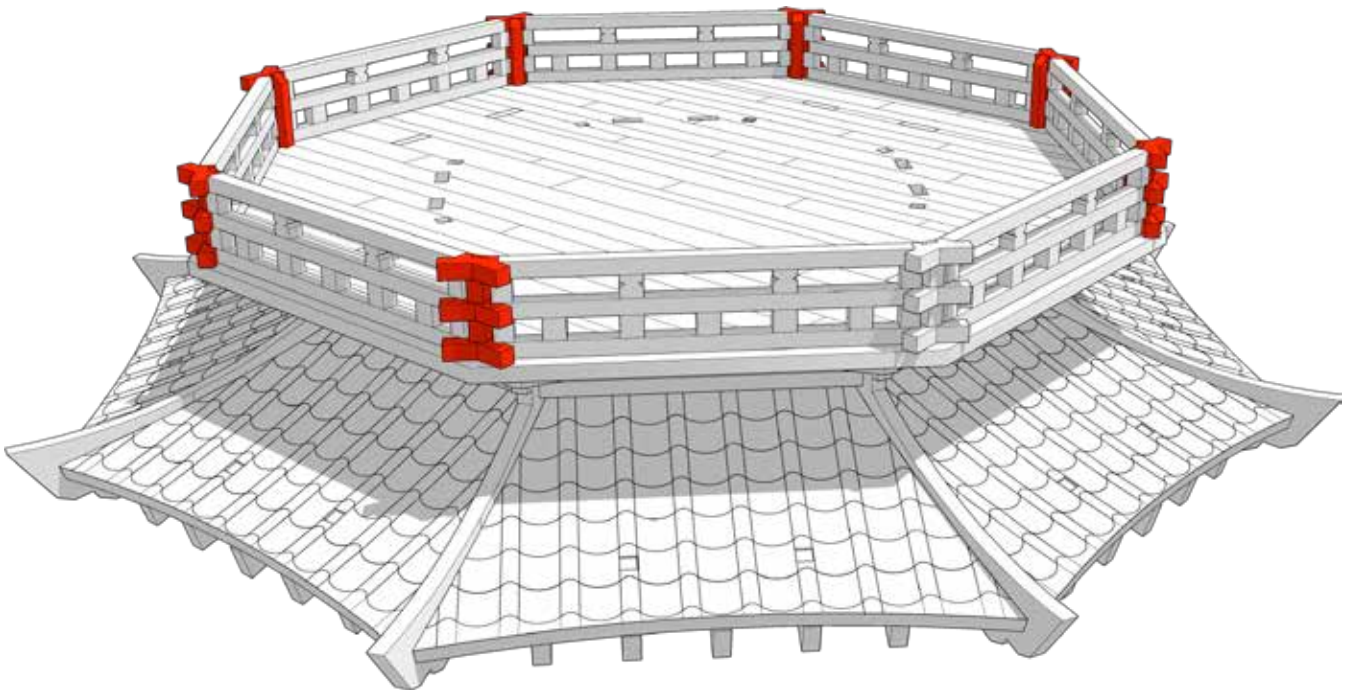

Repeat steps 176-179 for remaining fencing



TABLETOP SCENICS

TTSCW-EES-110
Toshi
Hakkei-tō Pagoda

193

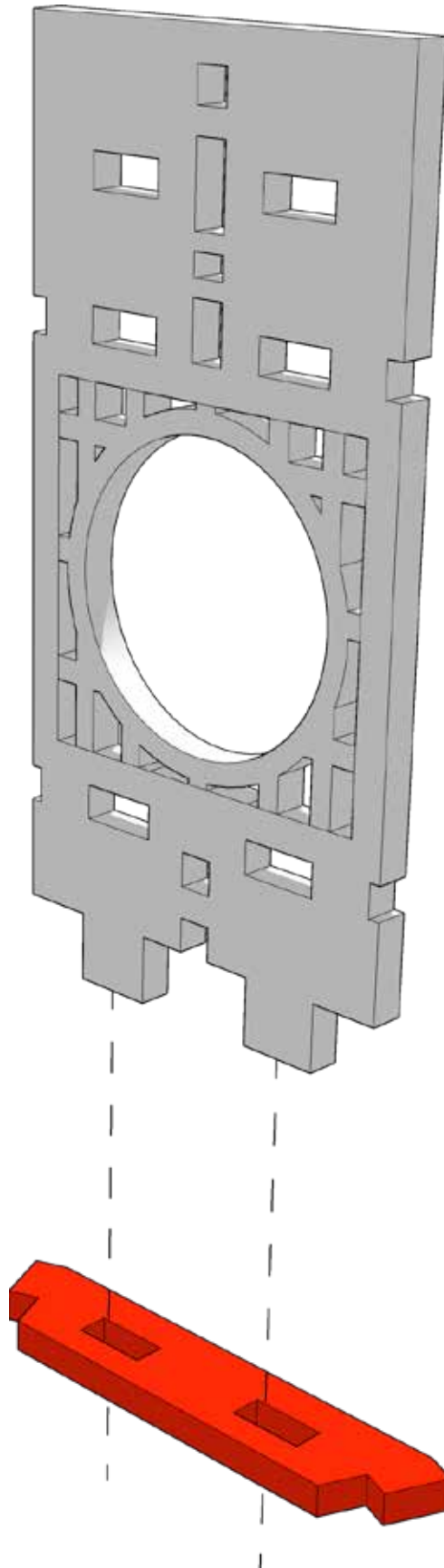



TABLETOP SCENICS

TTSCW-EES-110
Toshi
Hakkei-tō Pagoda

194

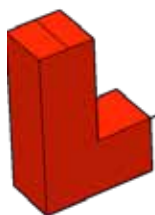
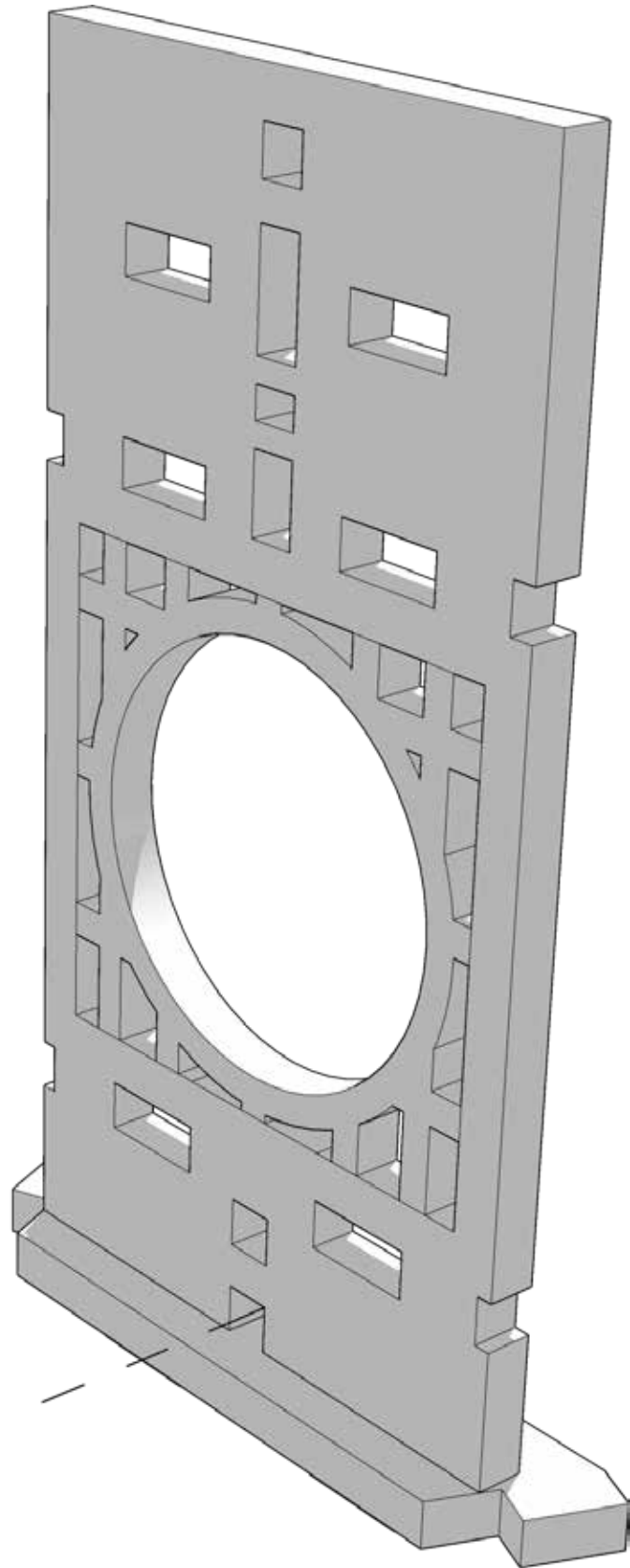



TABLETOP SCENICS

TTSCW-EES-110
Toshi
Hakkei-tō Pagoda

195

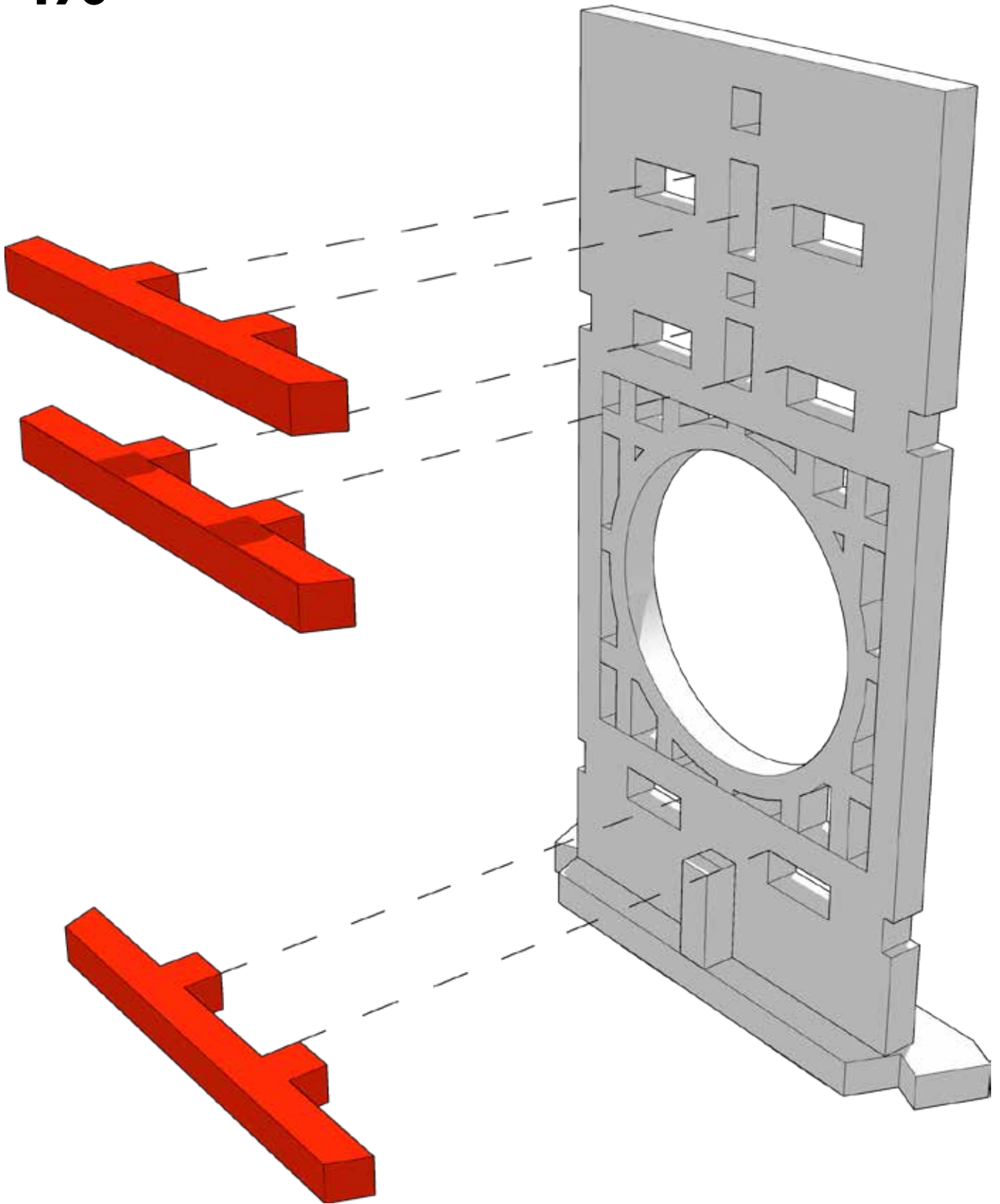



TABLETOP SCENICS

196

TTSCW-EES-110
Toshi
Hakkei-tō Pagoda

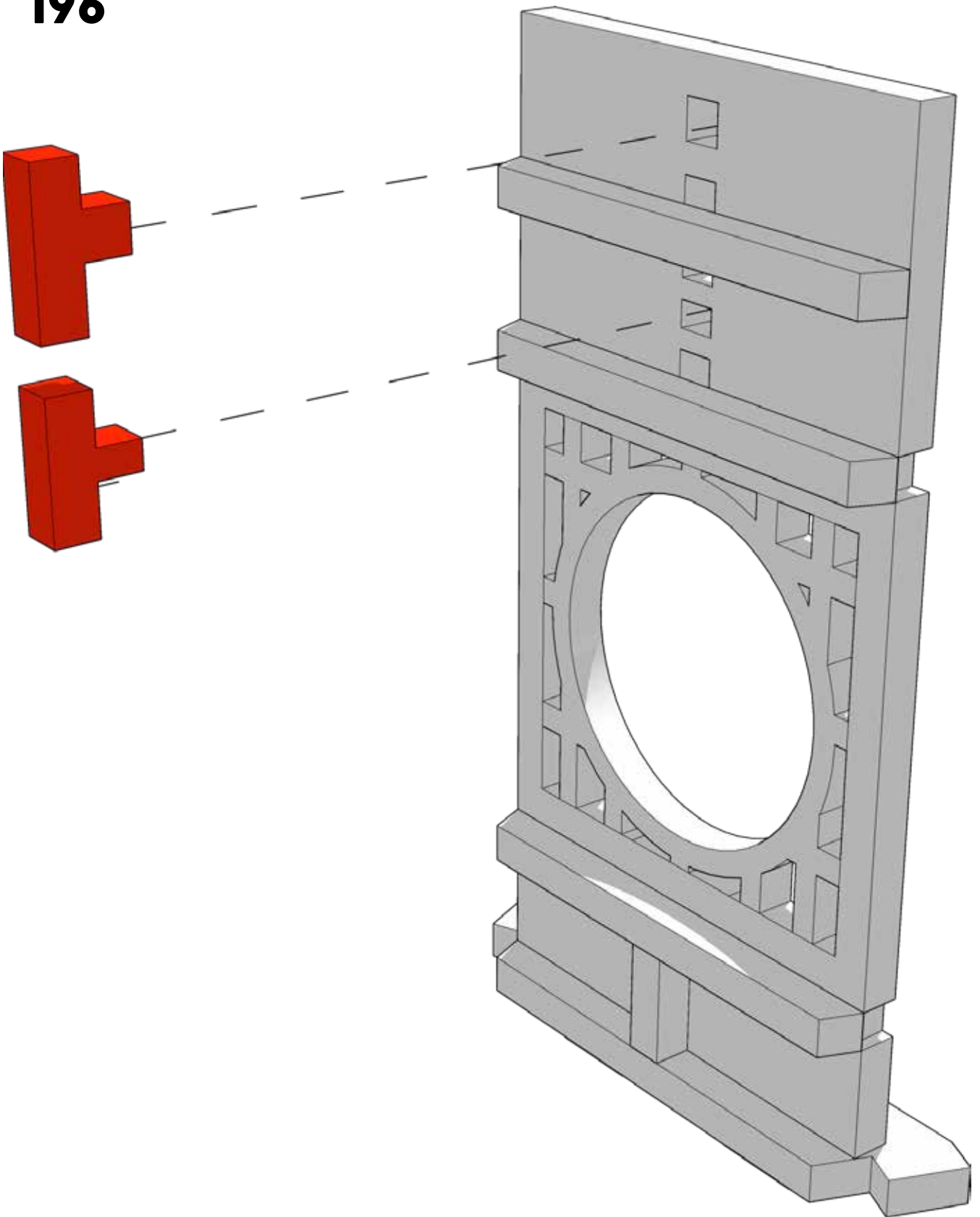



TABLETOP SCENICS

TTSCW-EES-110
Toshi
Hakkei-tō Pagoda

197

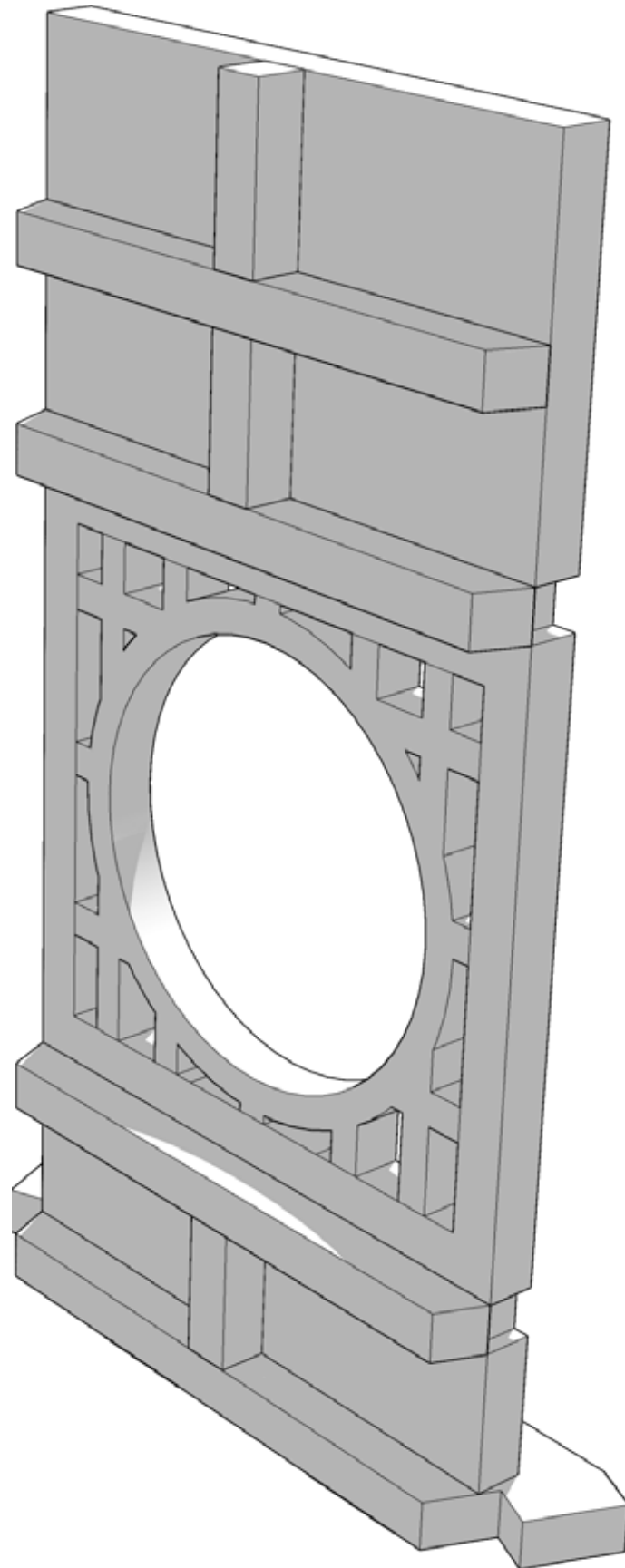



TABLETOP SCENICS

198

TTSCW-EES-110
Toshi
Hakkei-tō Pagoda

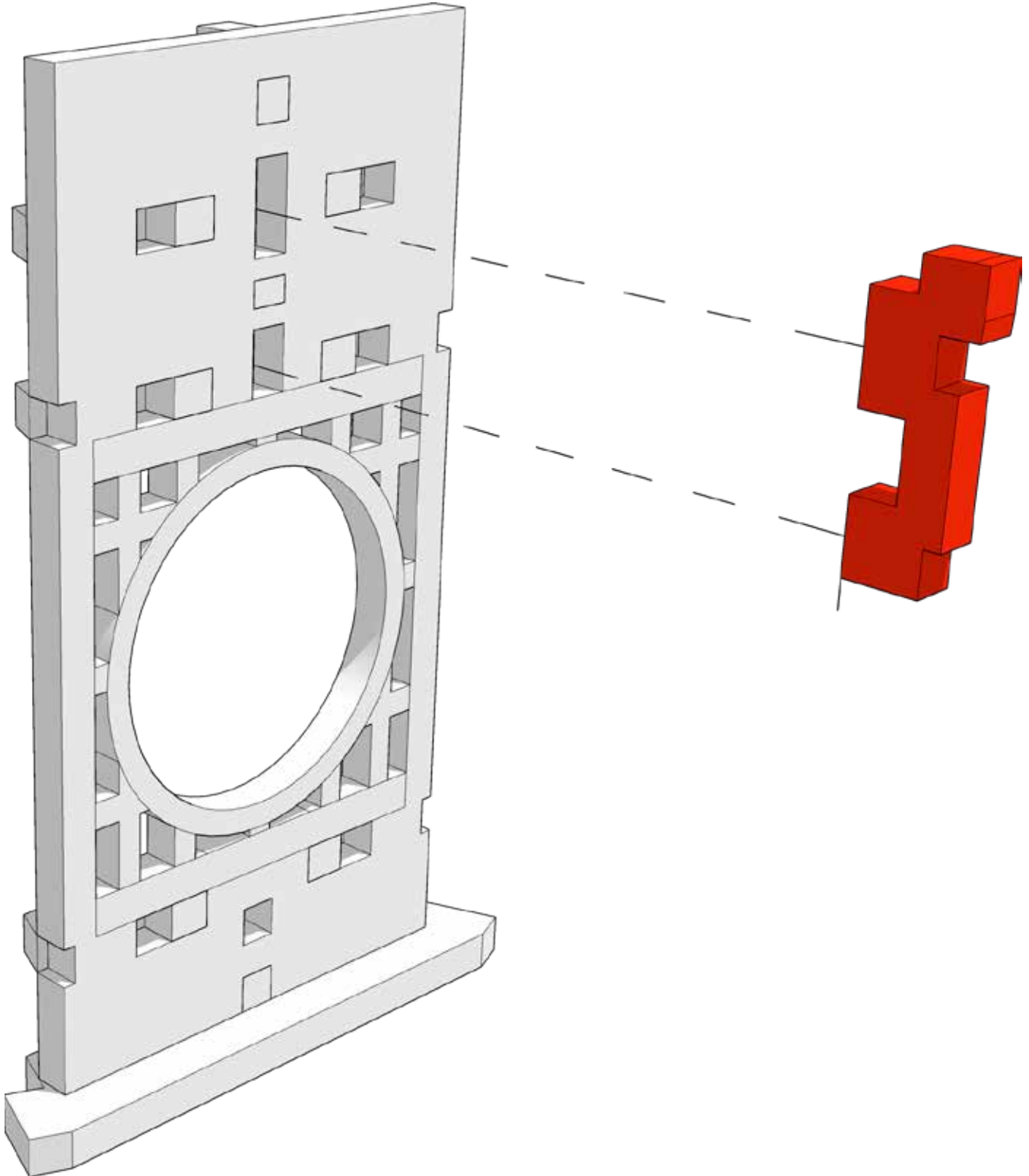



TABLETOP SCENICS

TTSCW-EES-110
Toshi
Hakkei-tō Pagoda

199

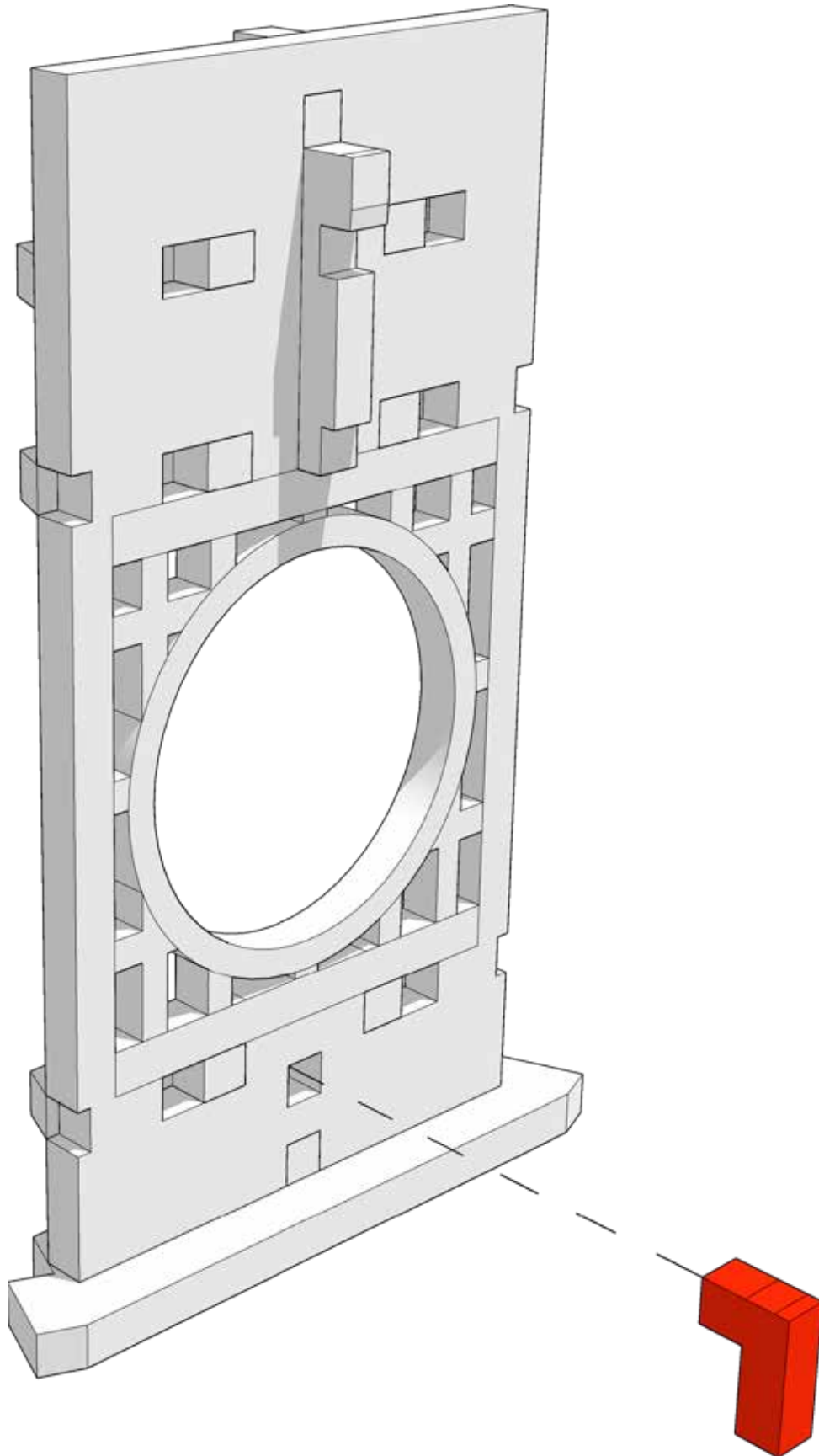



TABLETOP SCENICS

TTSCW-EES-110
Toshi
Hakkei-tō Pagoda

200

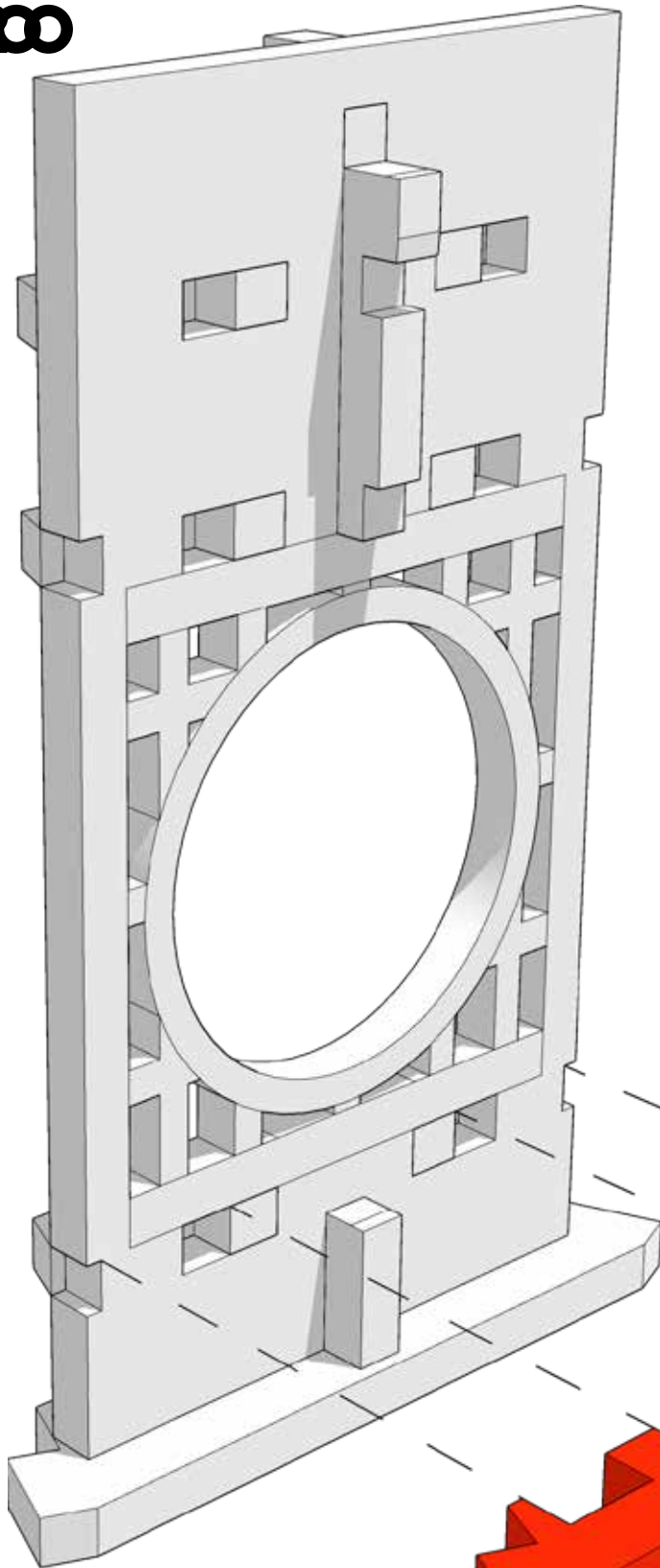

Highlighted part is marked
T1 on the sprue



TABLETOP SCENICS

201

TTSCW-EES-110
Toshi
Hakkei-tō Pagoda

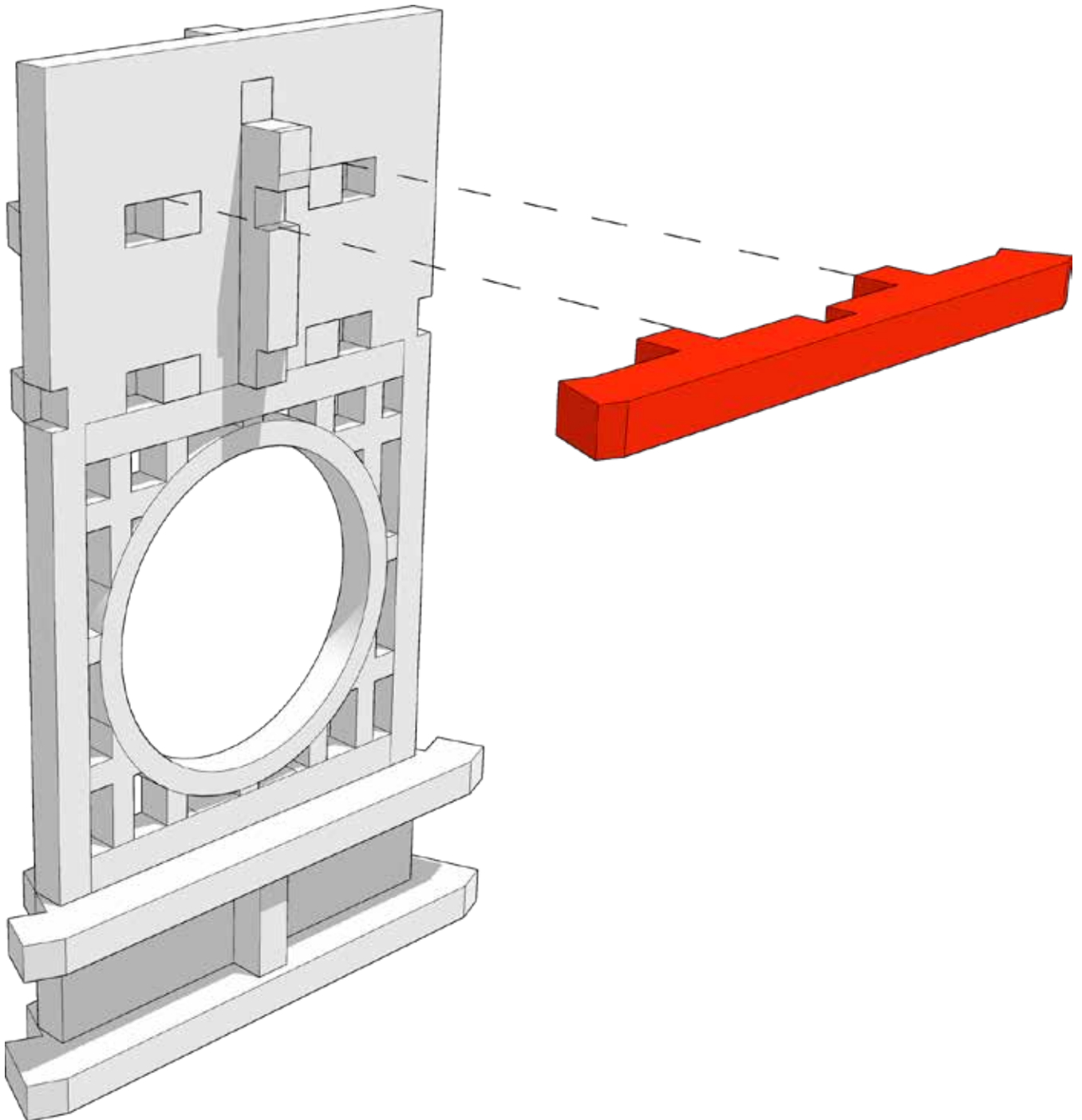



TABLETOP SCENICS

202

TTSCW-EES-110
Toshi
Hakkei-tō Pagoda

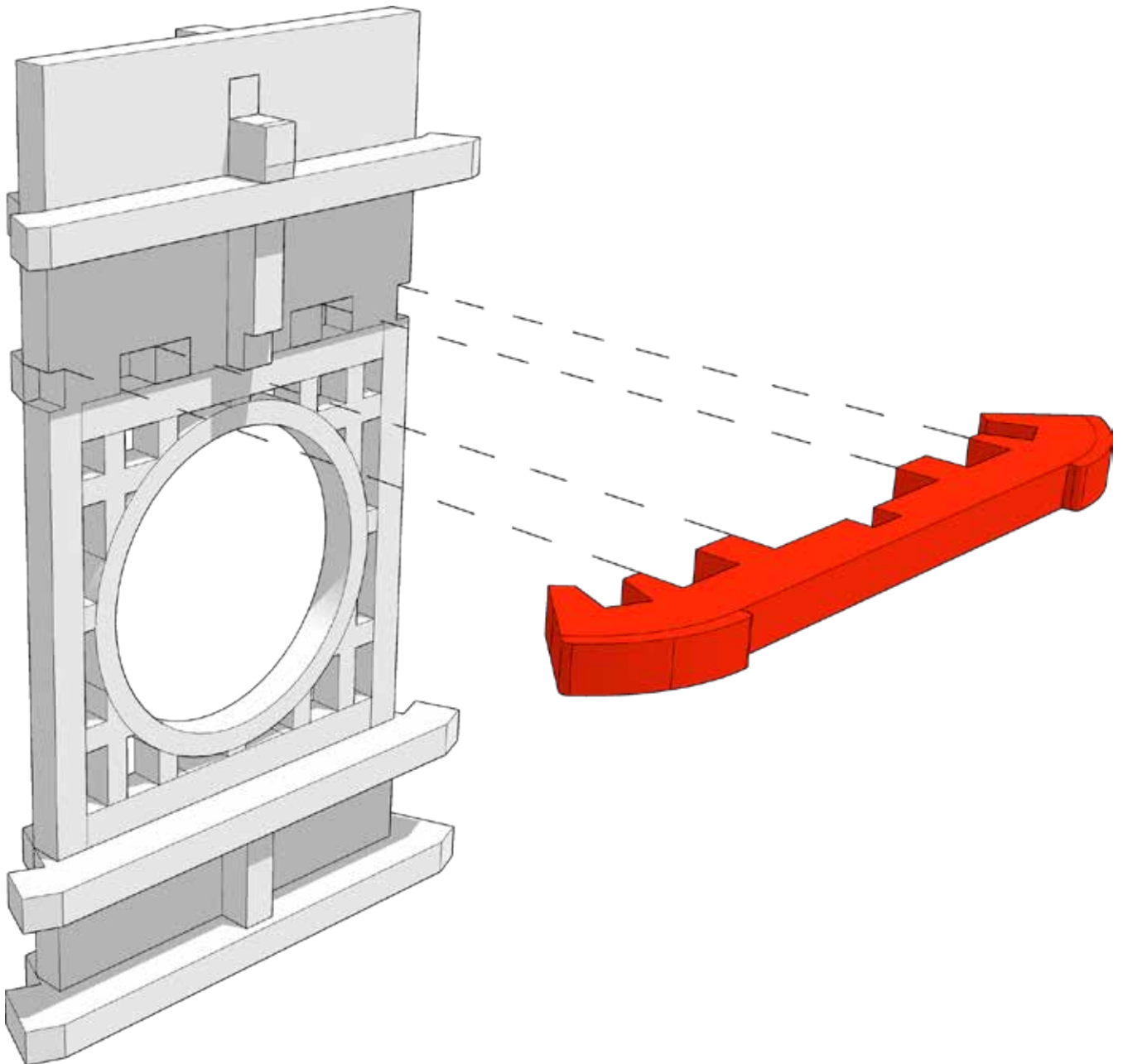



TABLETOP SCENICS

203

TTSCW-EES-110
Toshi
Hakkei-tō Pagoda

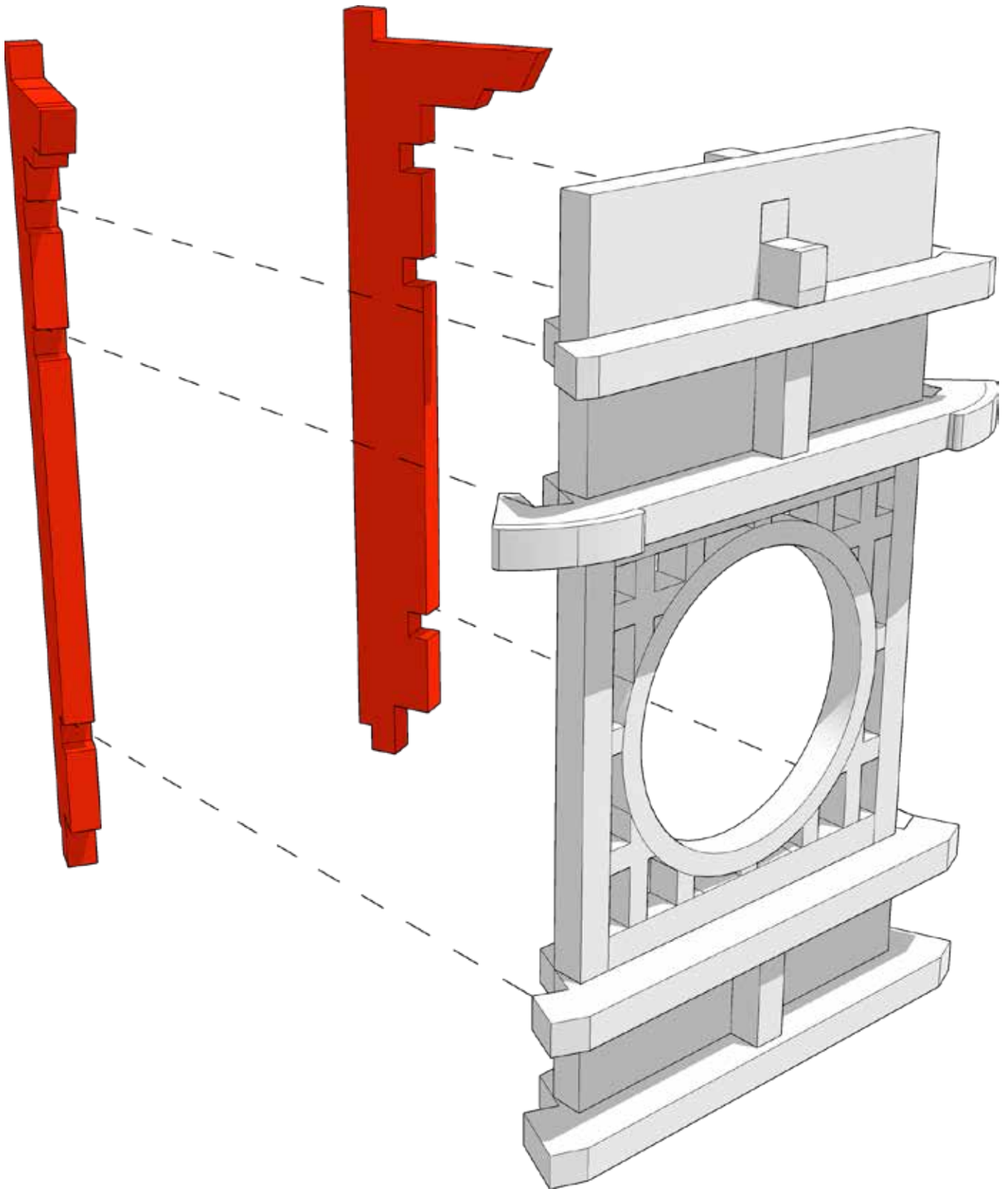



TABLETOP SCENICS

TTSCW-EES-110
Toshi
Hakkei-tō Pagoda

204

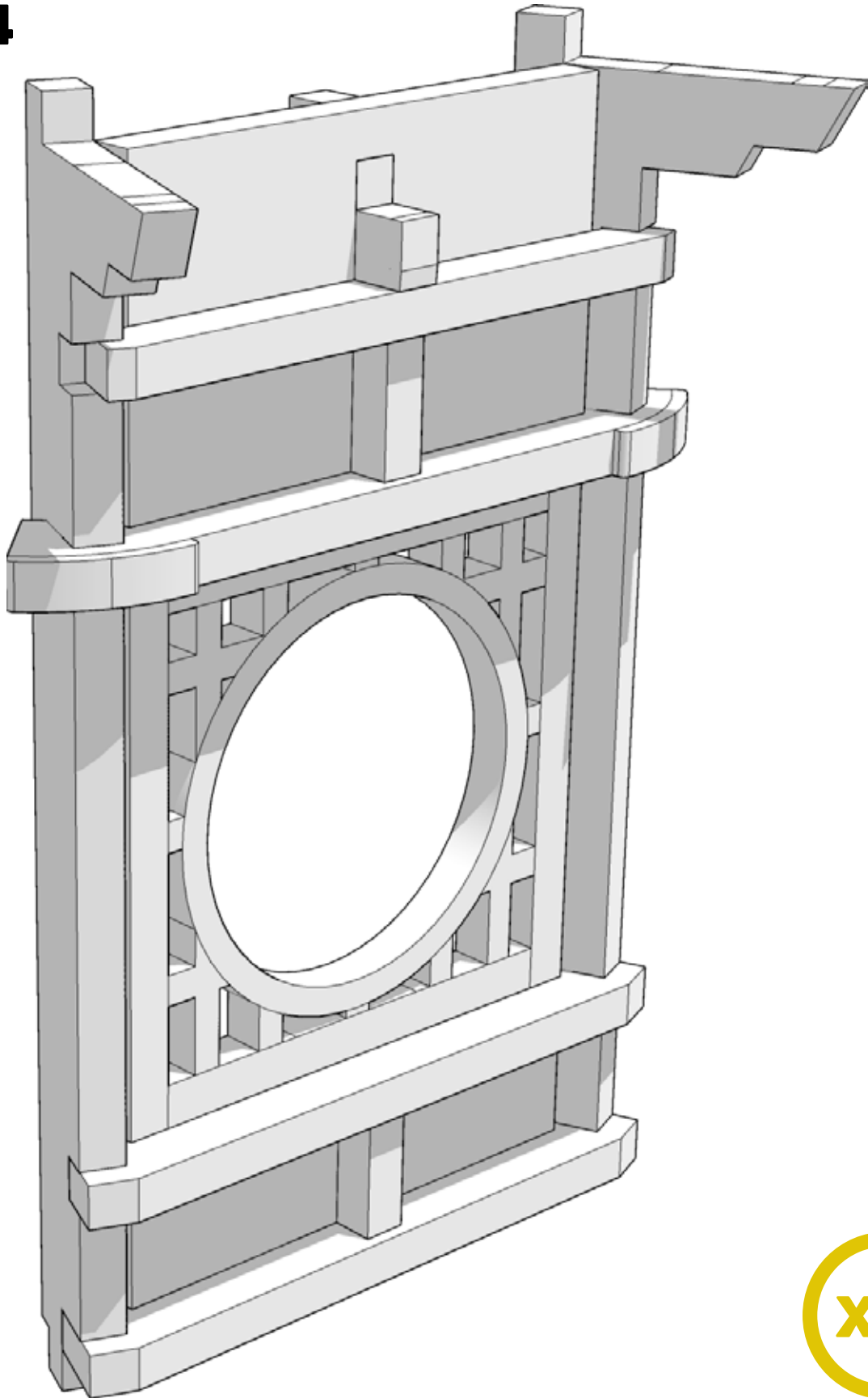

x4

 TTCOMBAT



TABLETOP SCENICS

205

TTSCW-EES-110
Toshi
Hakkei-tō Pagoda

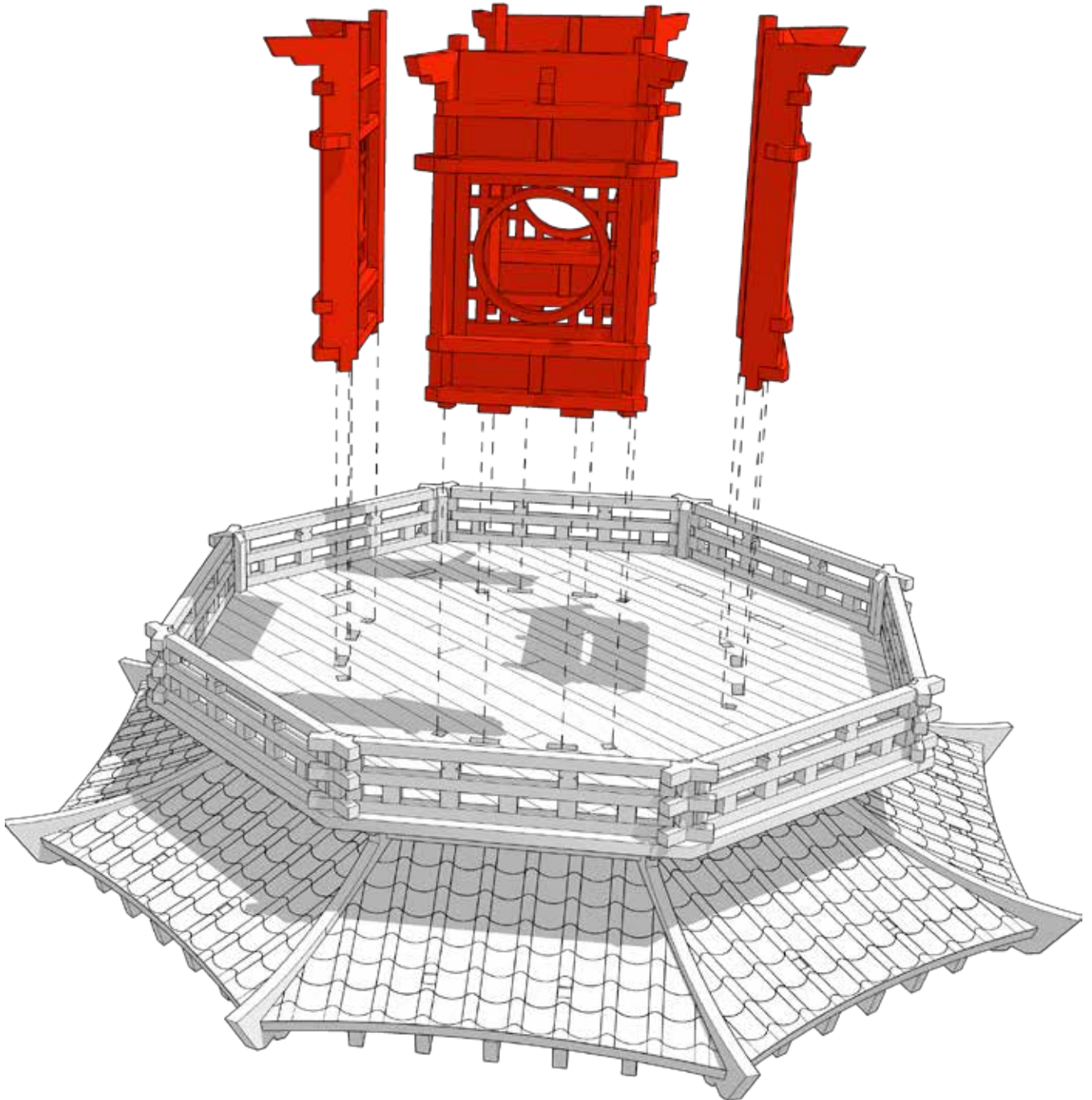



TABLETOP SCENICS

206

TTSCW-EES-110
Toshi
Hakkei-tō Pagoda

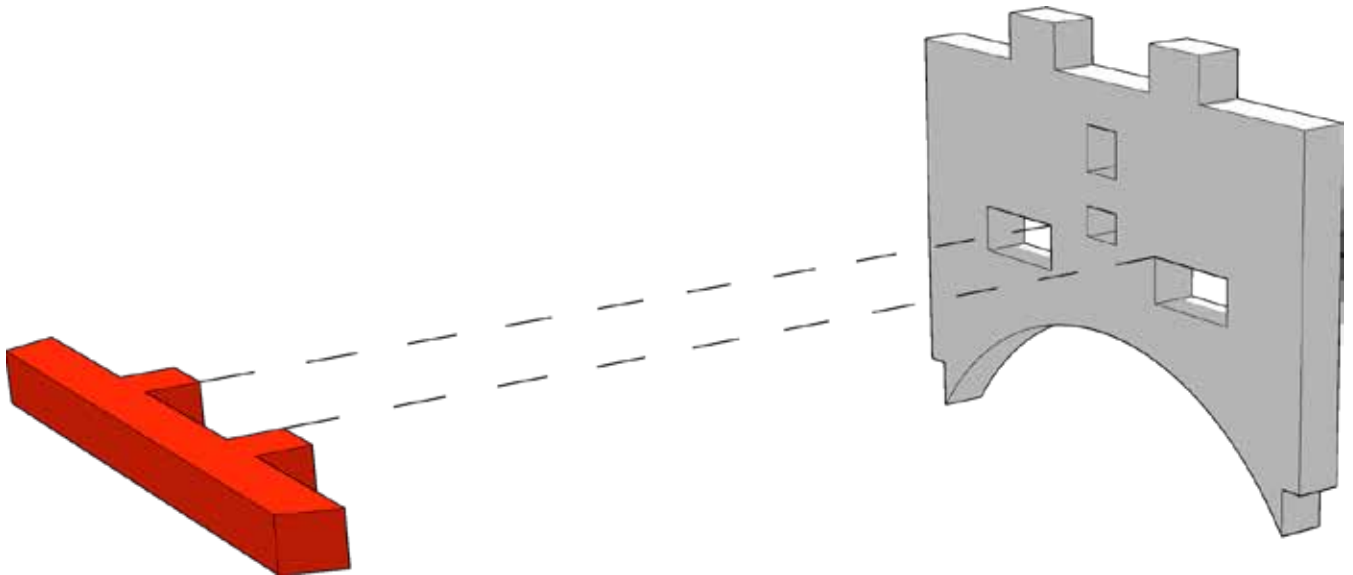



TABLETOP SCENICS

207

TTSCW-EES-110
Toshi
Hakkei-tō Pagoda

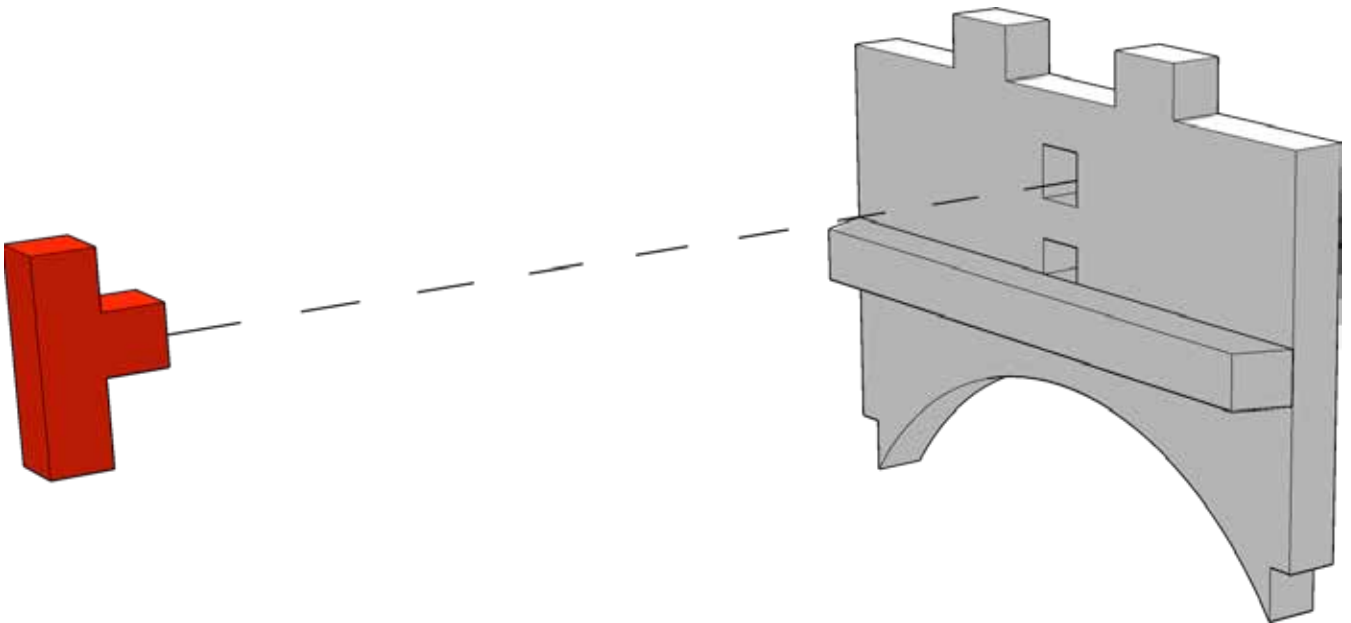



TABLETOP SCENICS

TTSCW-EES-110
Toshi
Hakkei-tō Pagoda

208

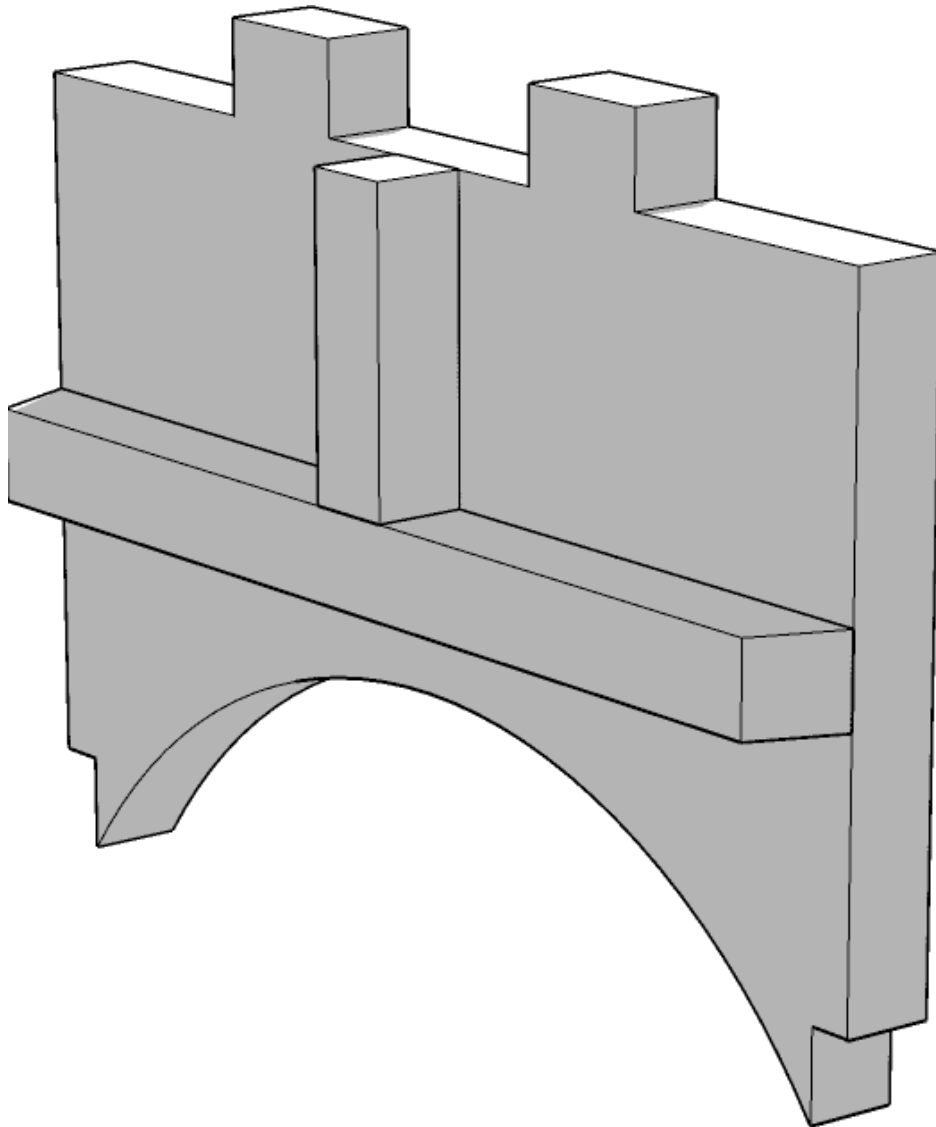



TABLETOP SCENICS

209

TTSCW-EES-110
Toshi
Hakkei-tō Pagoda

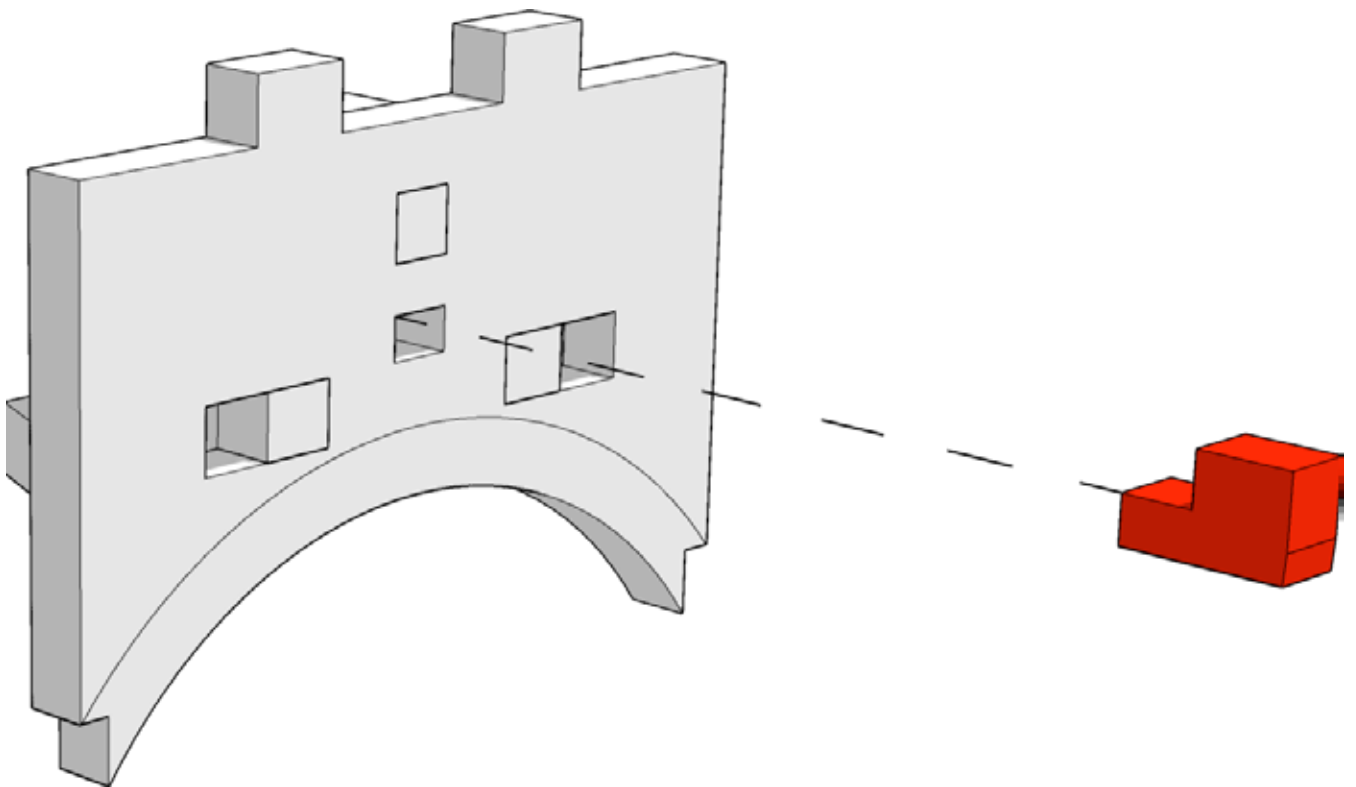



TABLETOP SCENICS

TTSCW-EES-110
Toshi
Hakkei-tō Pagoda

210

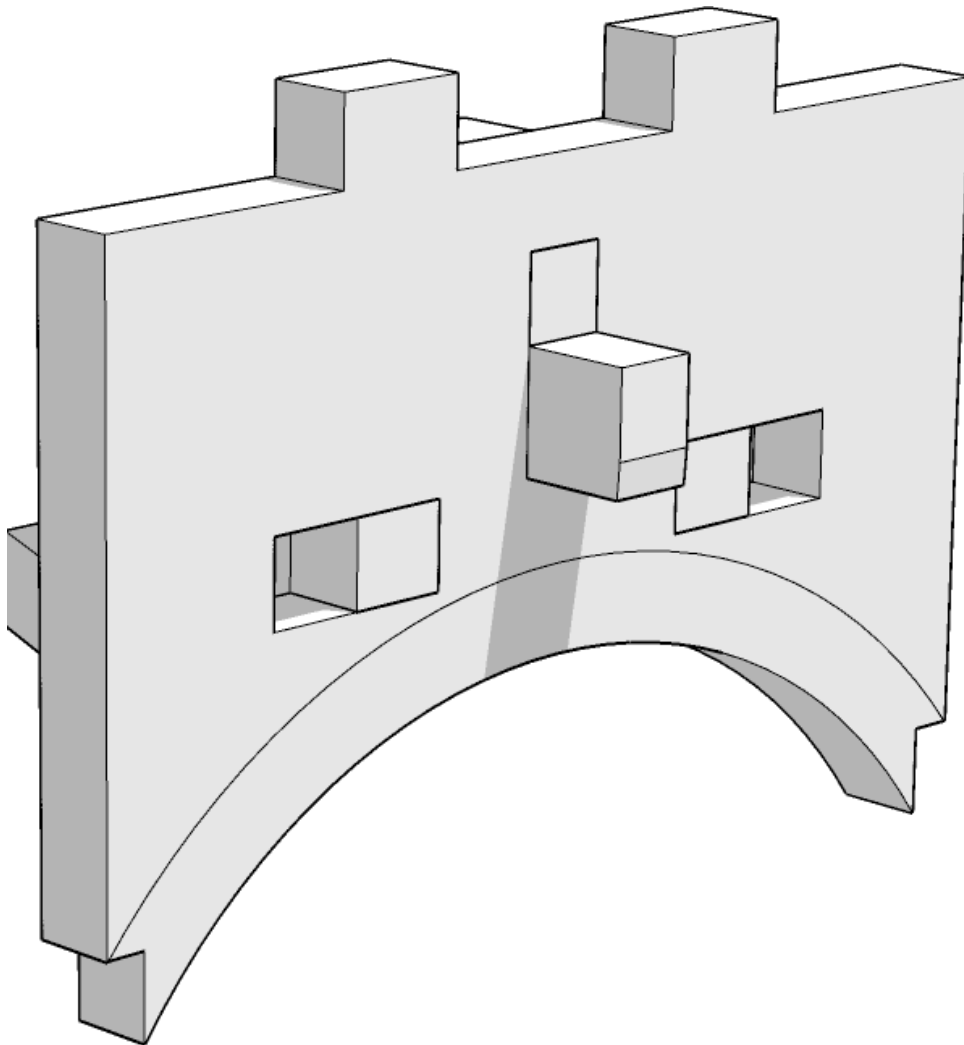

x4

 TTCOMBAT



TABLETOP SCENICS

TTSCW-EES-110
Toshi
Hakkei-tō Pagoda

211

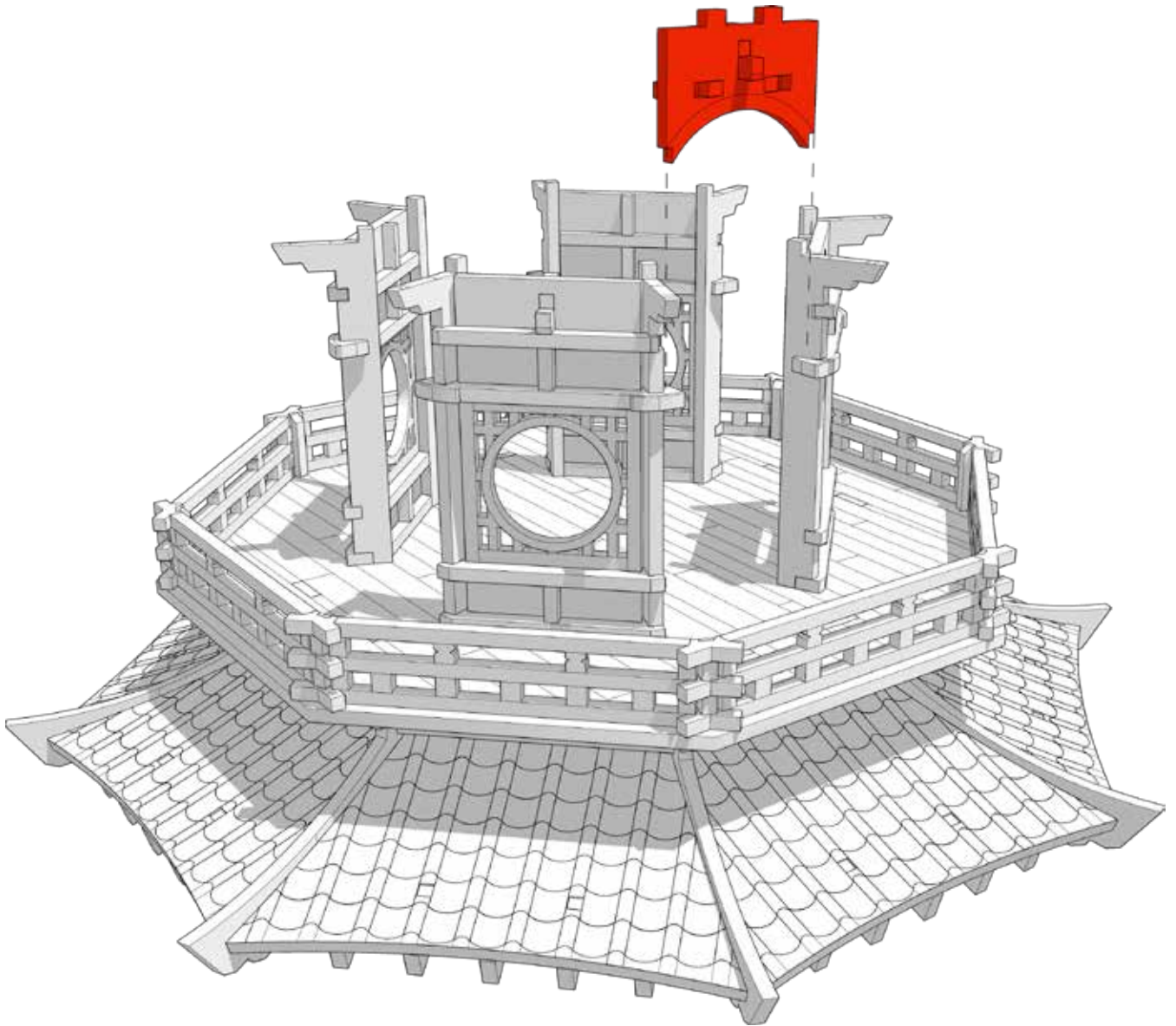



TABLETOP SCENICS

212

TTSCW-EES-110
Toshi
Hakkei-tō Pagoda

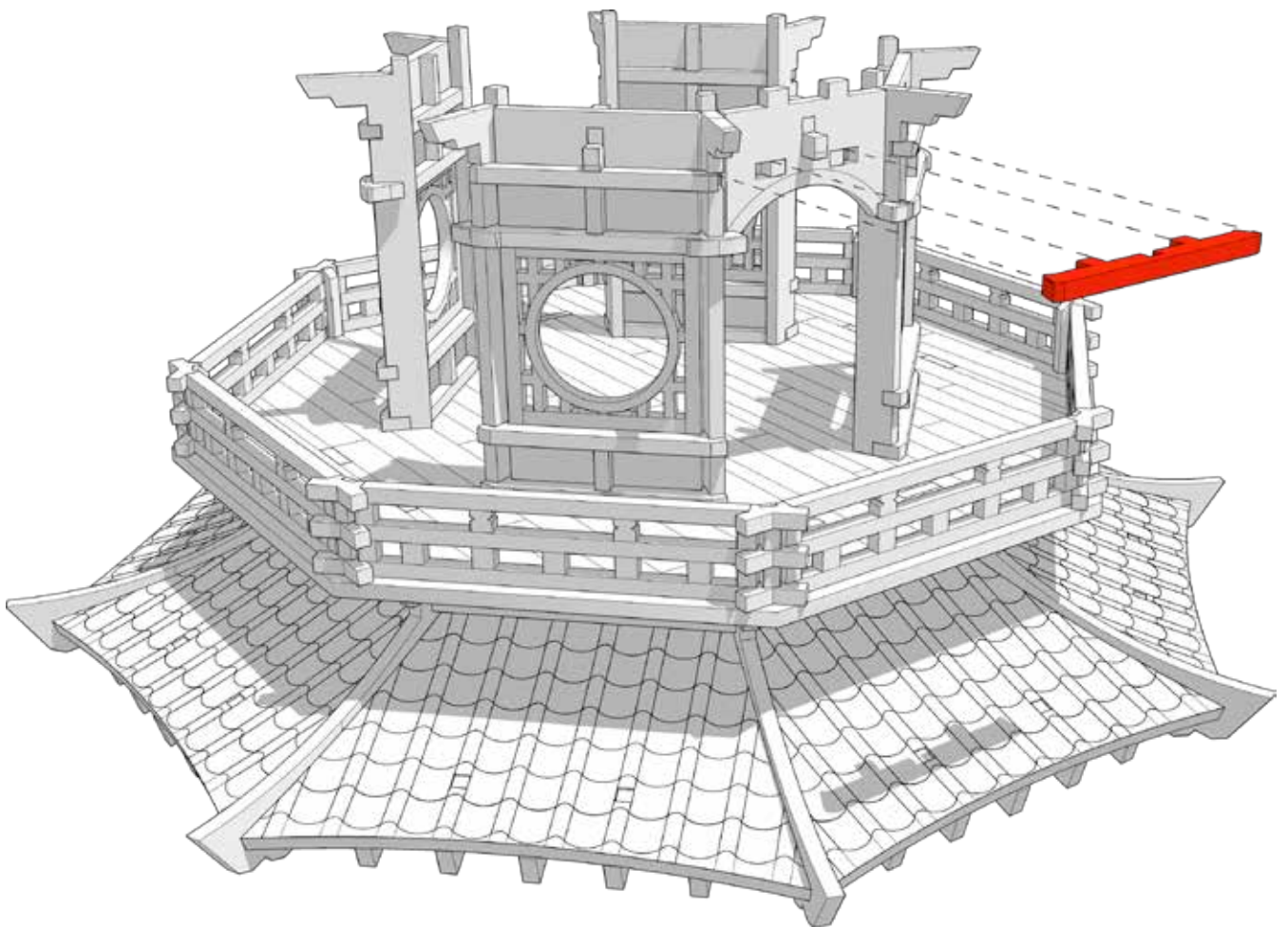



TABLETOP SCENICS

213

TTSCW-EES-110
Toshi
Hakkei-tō Pagoda

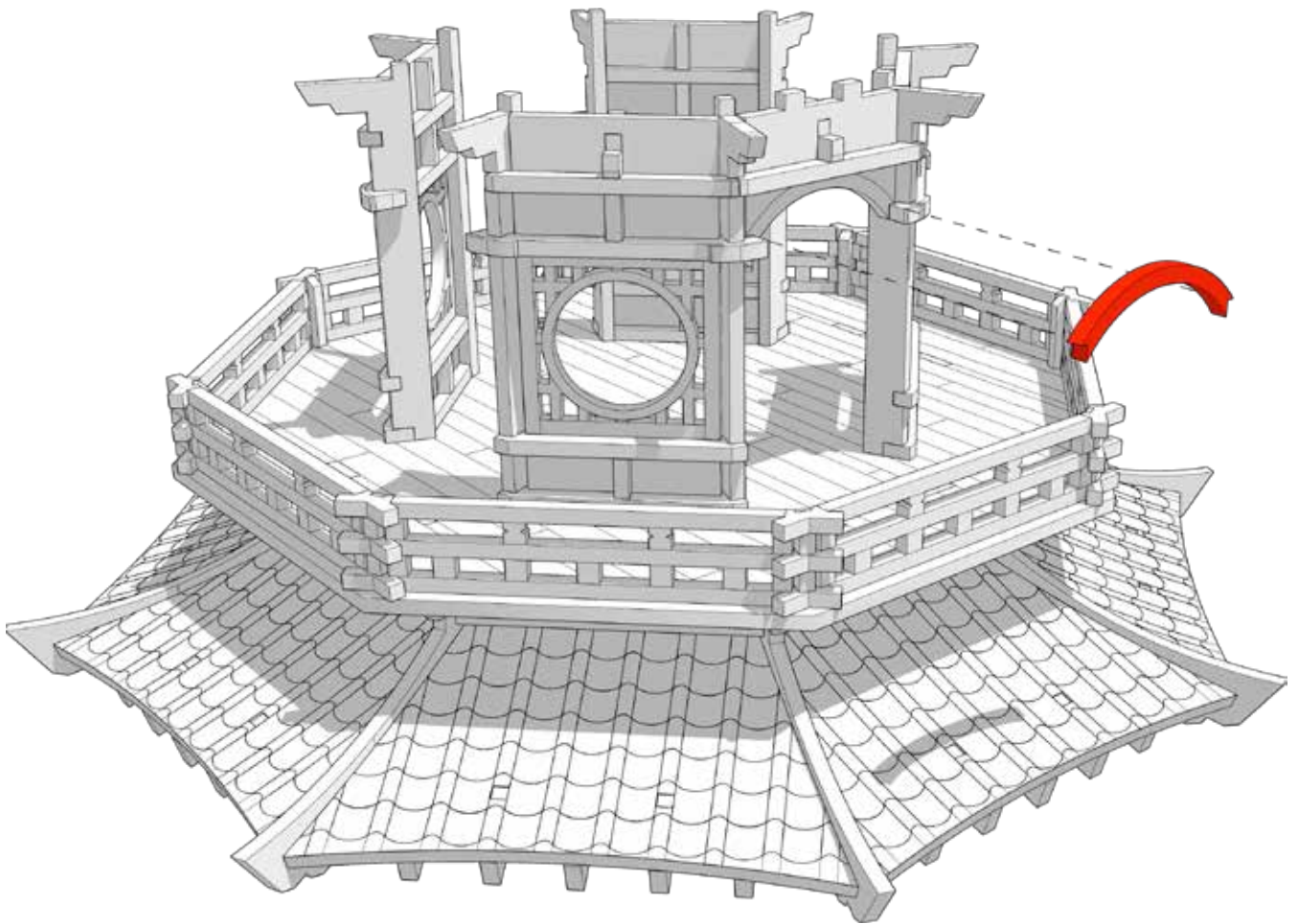



TABLETOP SCENICS

214

TTSCW-EES-110
Toshi
Hakkei-tō Pagoda

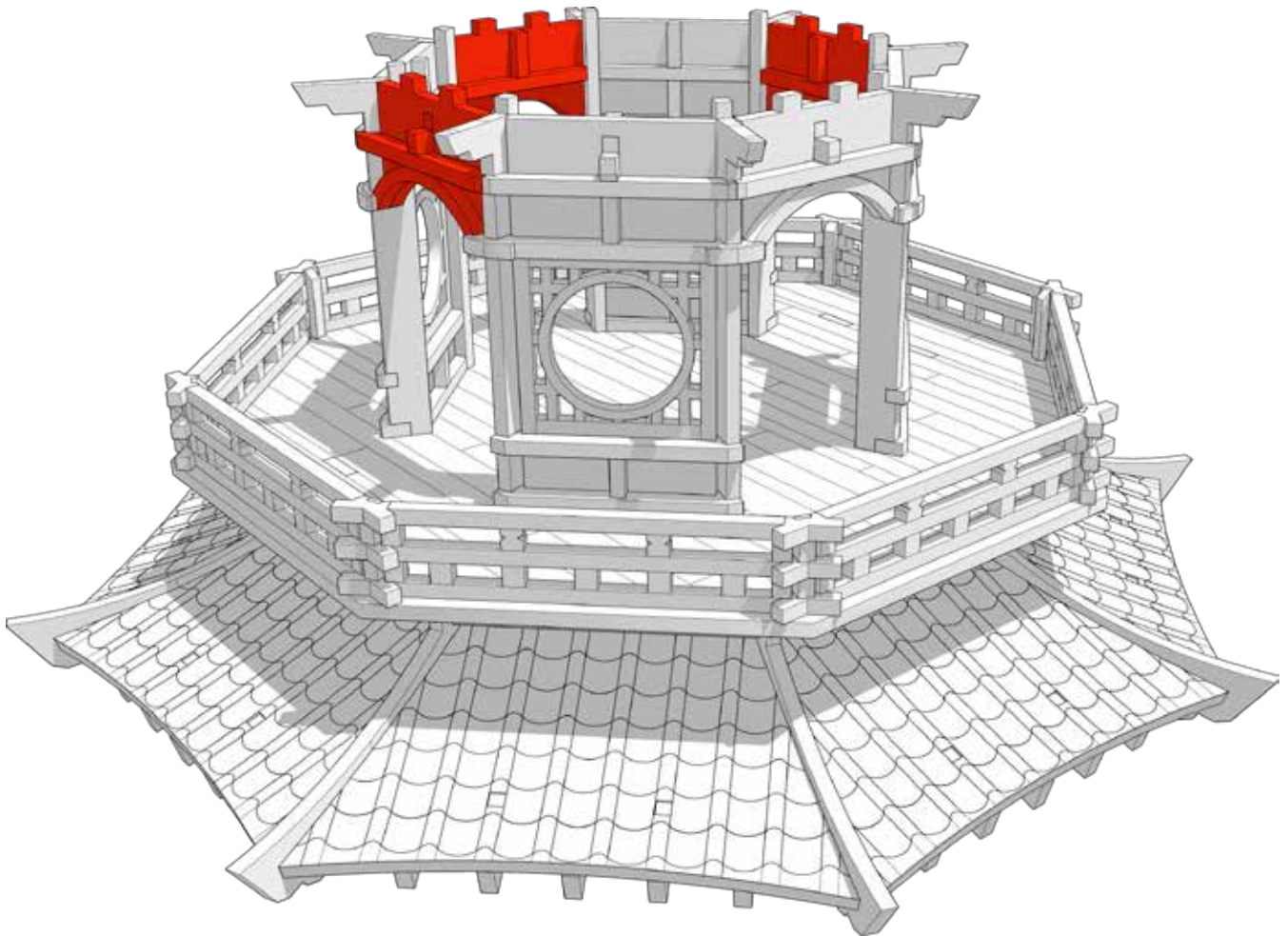

Repeat steps 199 - 201 for remaining sections



TABLETOP SCENICS

215

TTSCW-EES-110
Toshi
Hakkei-tō Pagoda

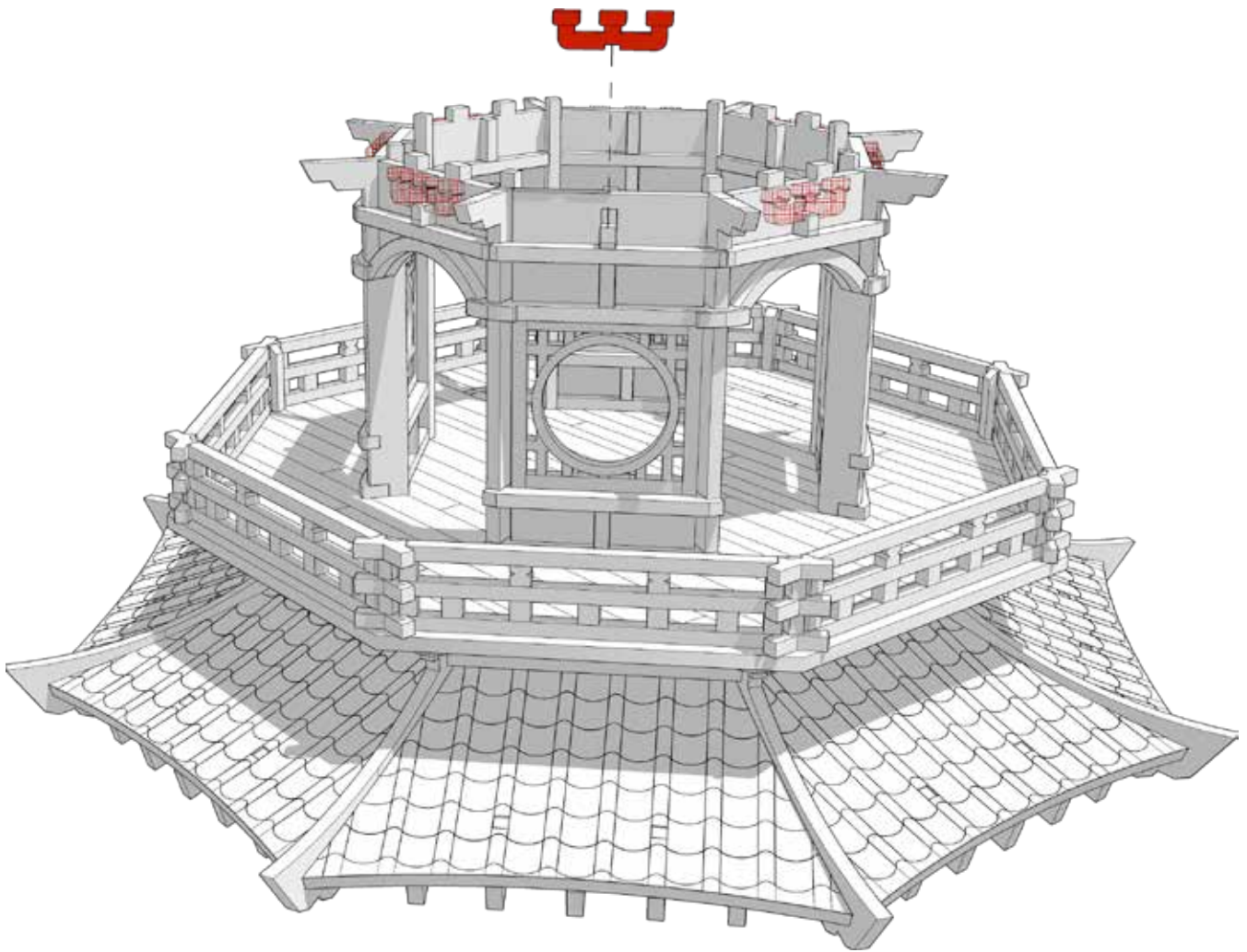

Repeat step around building



TABLETOP SCENICS

216

TTSCW-EES-110
Toshi
Hakkei-tō Pagoda

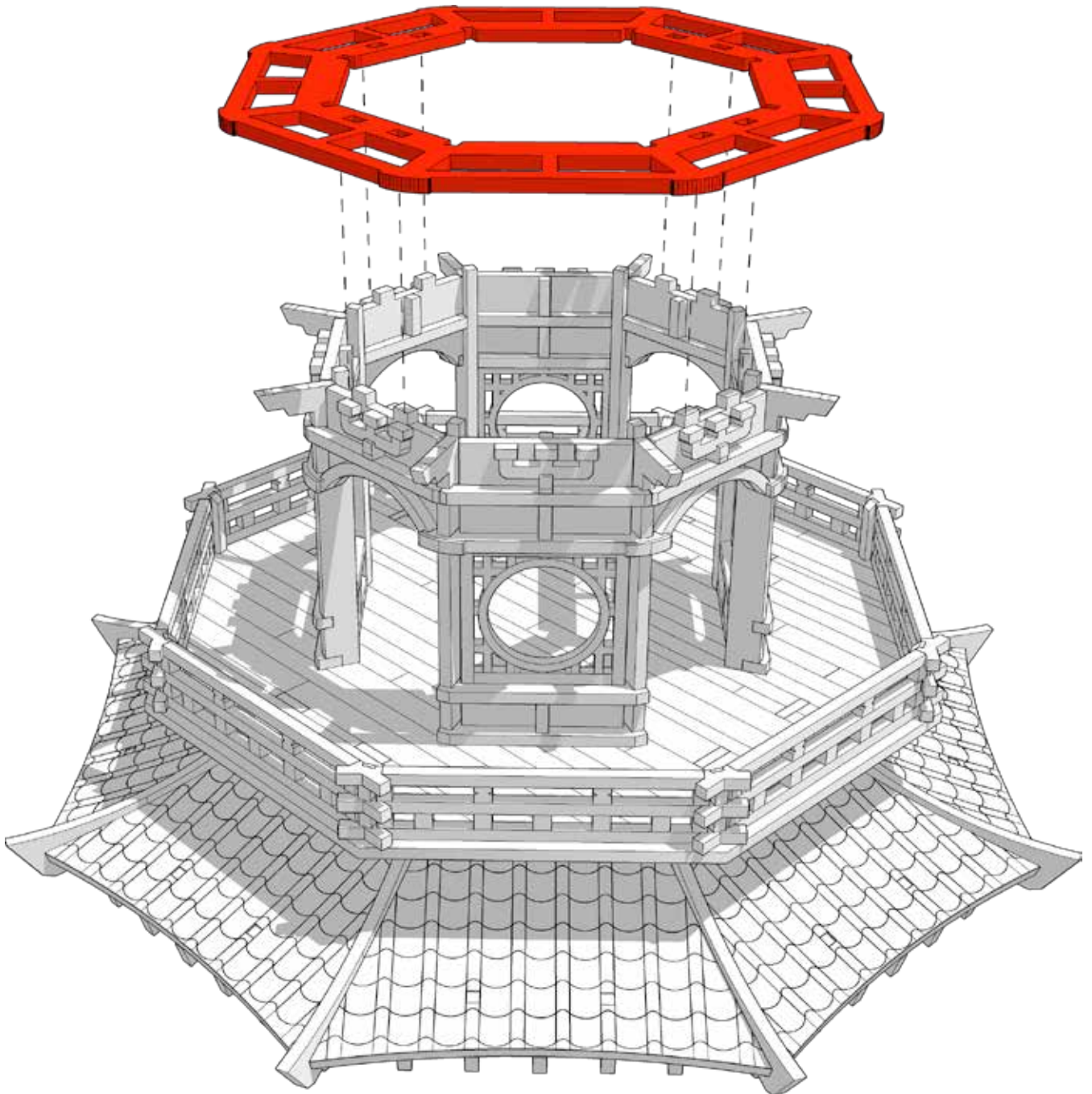



TABLETOP SCENICS

217

TTSCW-EES-110
Toshi
Hakkei-tō Pagoda

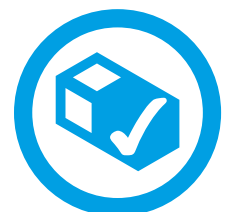
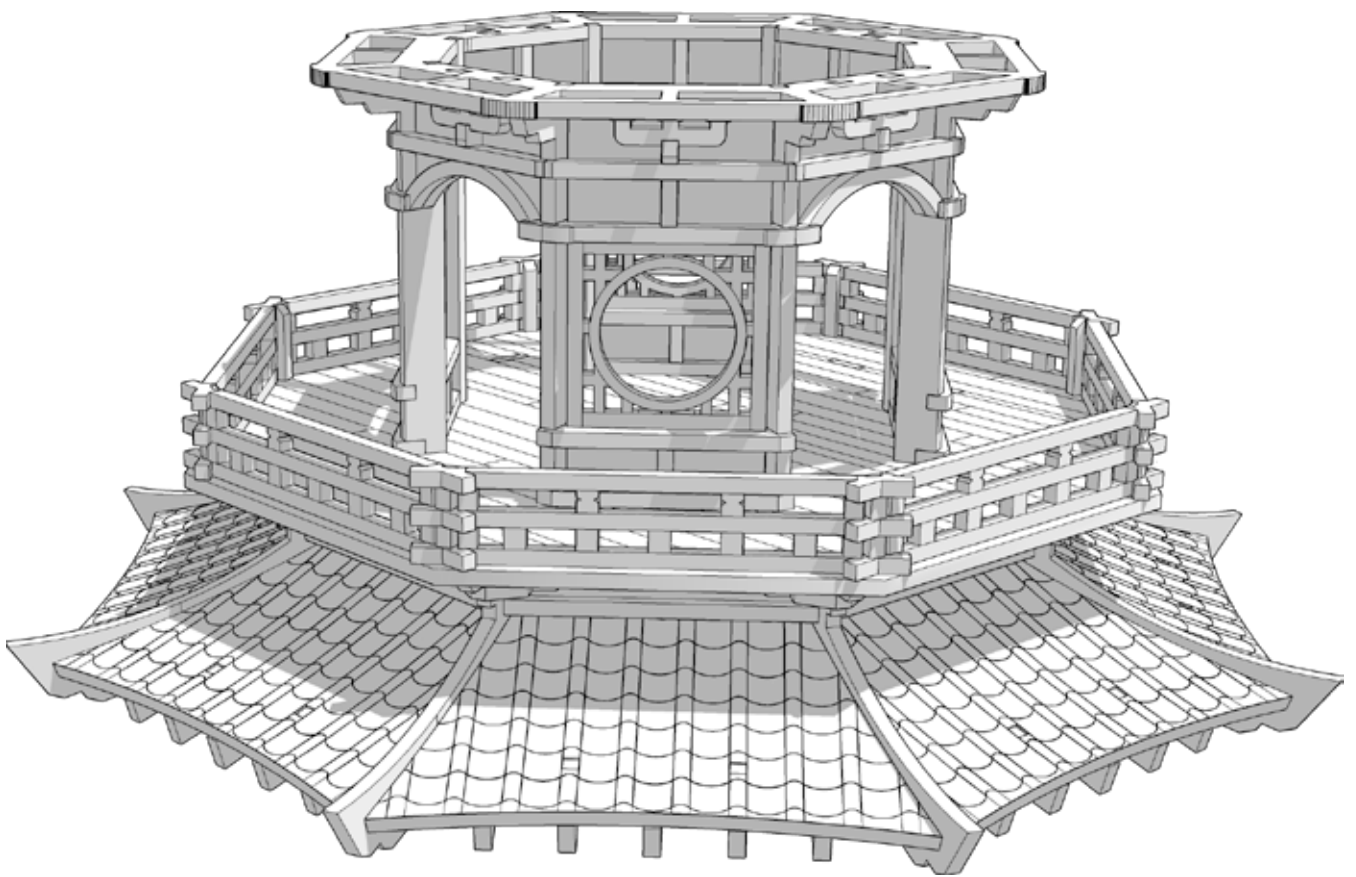

 TTCOMBAT



TABLETOP SCENICS

TTSCW-EES-110
Toshi
Hakkei-tō Pagoda

218

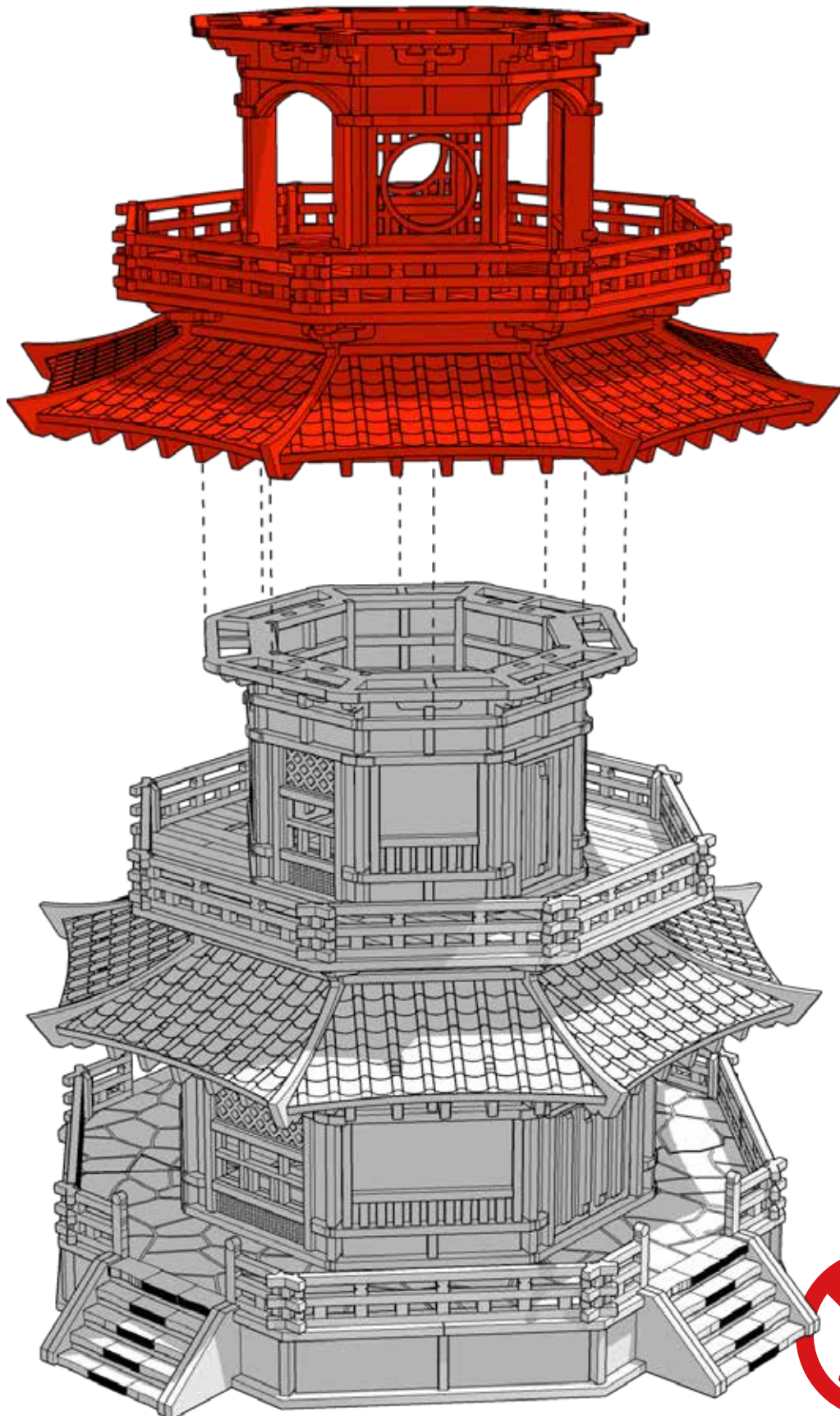

Do not glue. Order of levels is optional and can be added to with extension kits





TABLETOP SCENICS

TTSCW-EES-110
Toshi
Hakkei-tō Pagoda

219

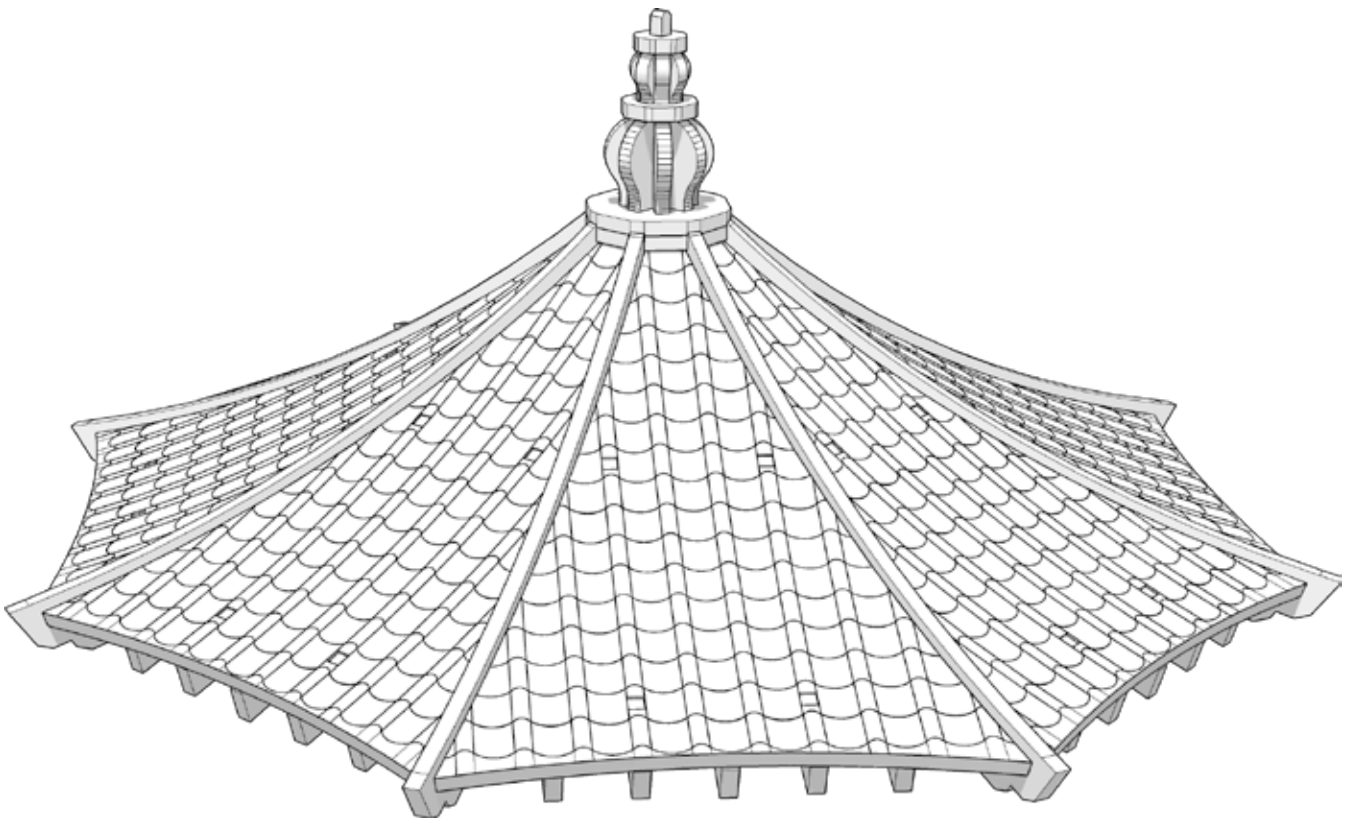

Hakkei-tō Roof



TABLETOP SCENICS

220

TTSCW-EES-110
Toshi
Hakkei-tō Pagoda

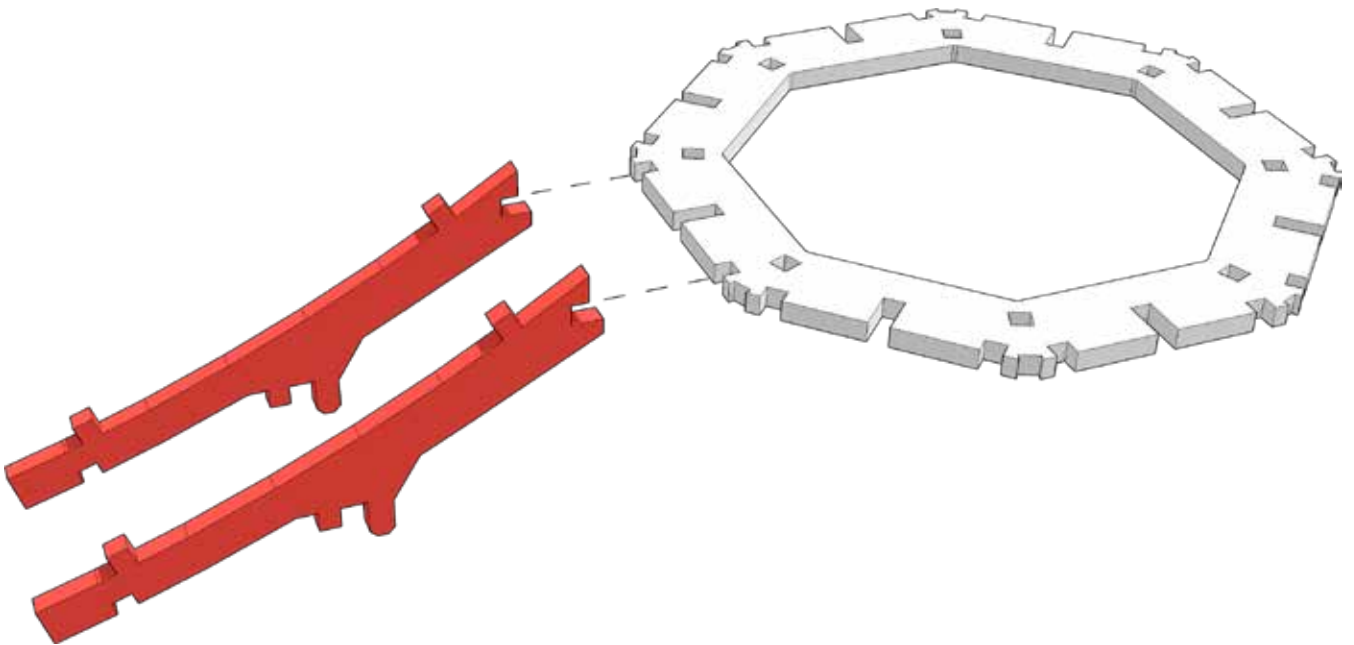

If you havent, check the following steps 185-193. Whilst simple, the roof is built best with consistent construction. Using PVA would be best as its slow drying



 **TTCOMBAT**



TABLETOP SCENICS

221

TTSCW-EES-110
Toshi
Hakkei-tō Pagoda

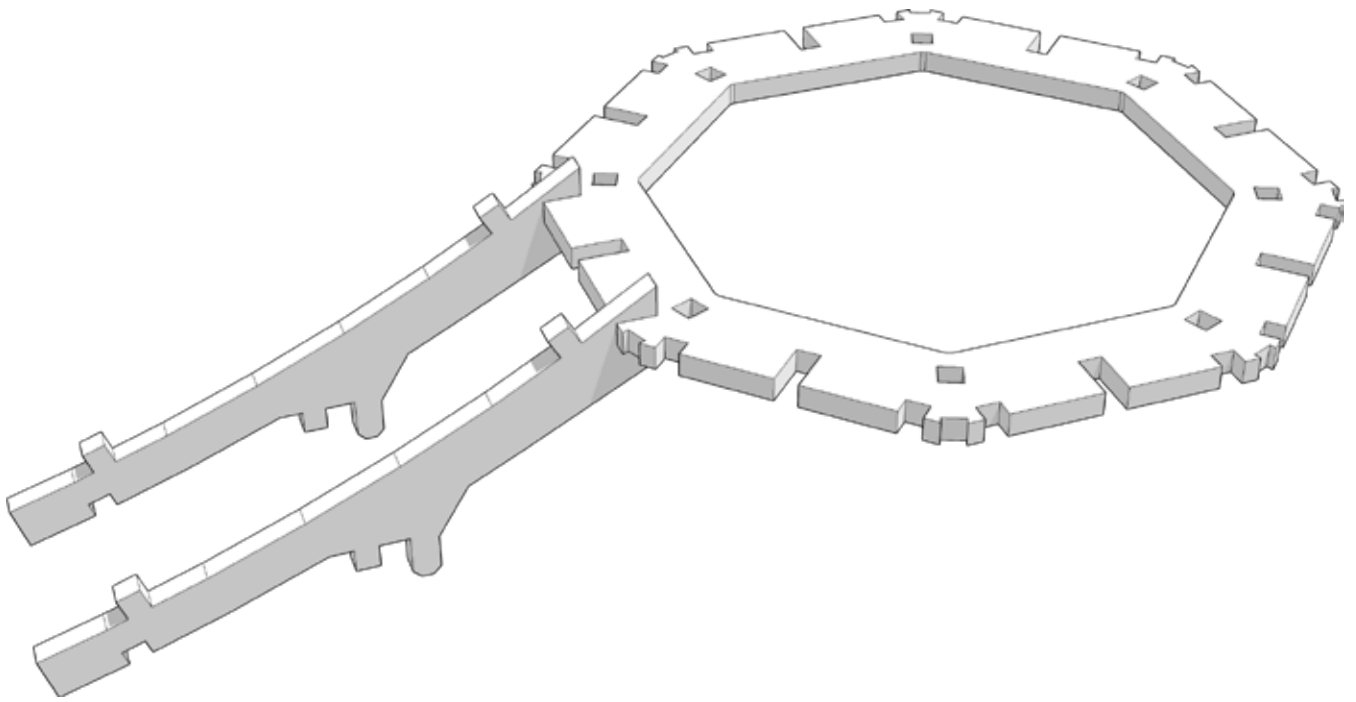



TABLETOP SCENICS

222

TTSCW-EES-110
Toshi
Hakkei-tō Pagoda

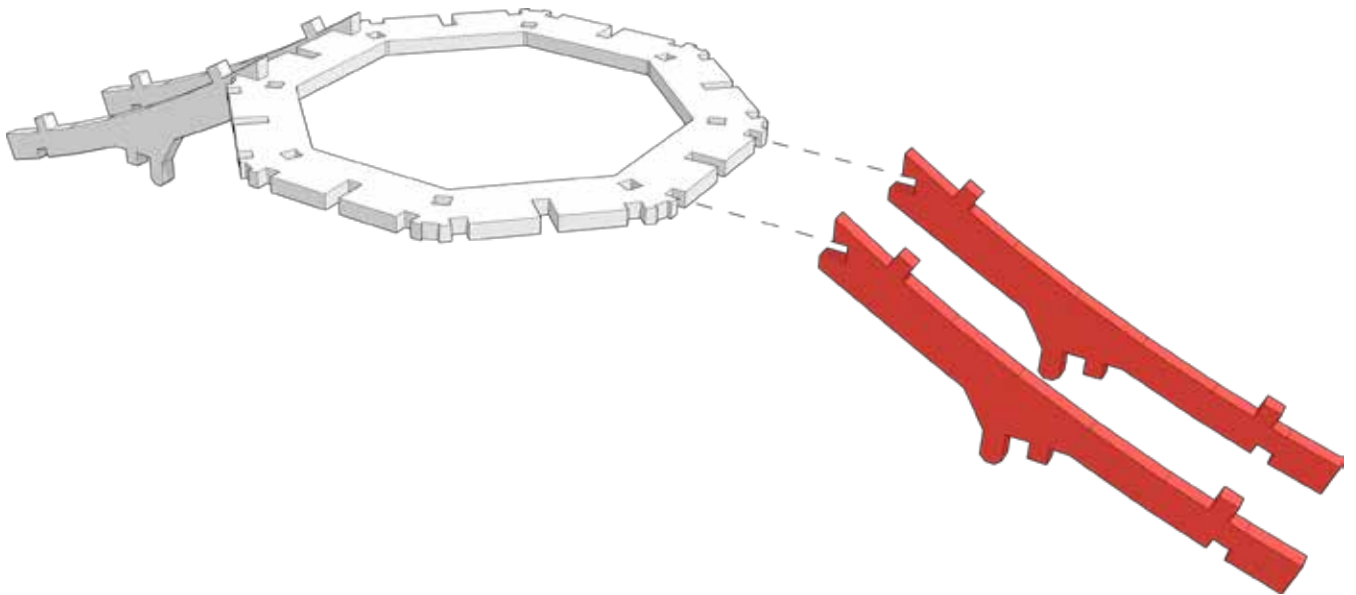



TABLETOP SCENICS

223

TTSCW-EES-110
Toshi
Hakkei-tō Pagoda

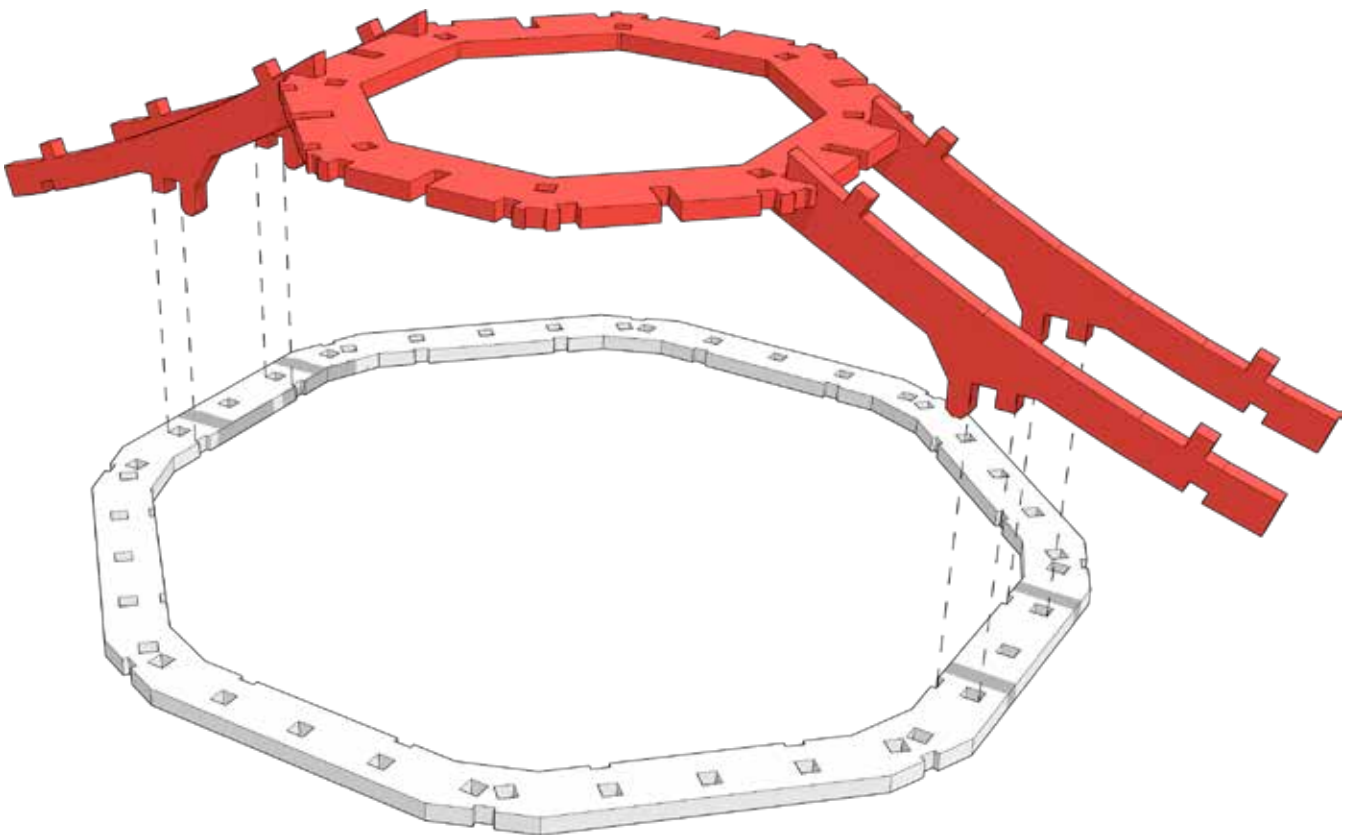



TABLETOP SCENICS

TTSCW-EES-110
Toshi
Hakkei-tō Pagoda

224

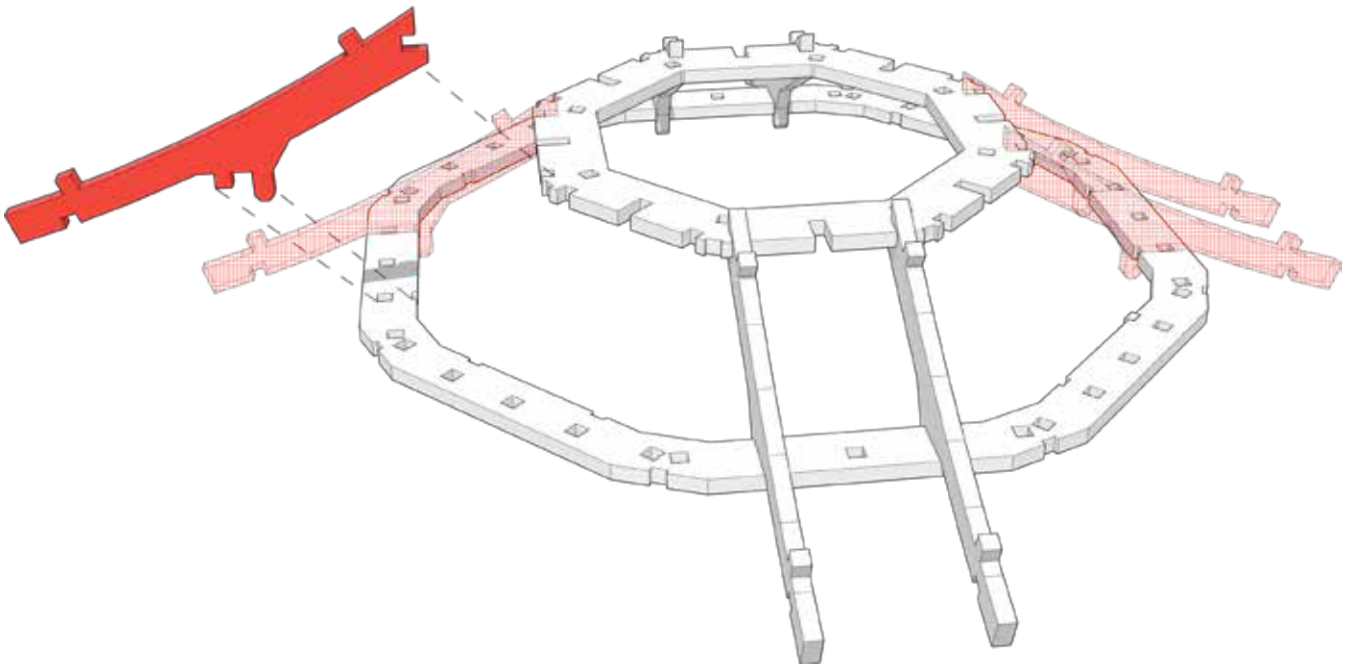



TABLETOP SCENICS

225

TTSCW-EES-110
Toshi
Hakkei-tō Pagoda

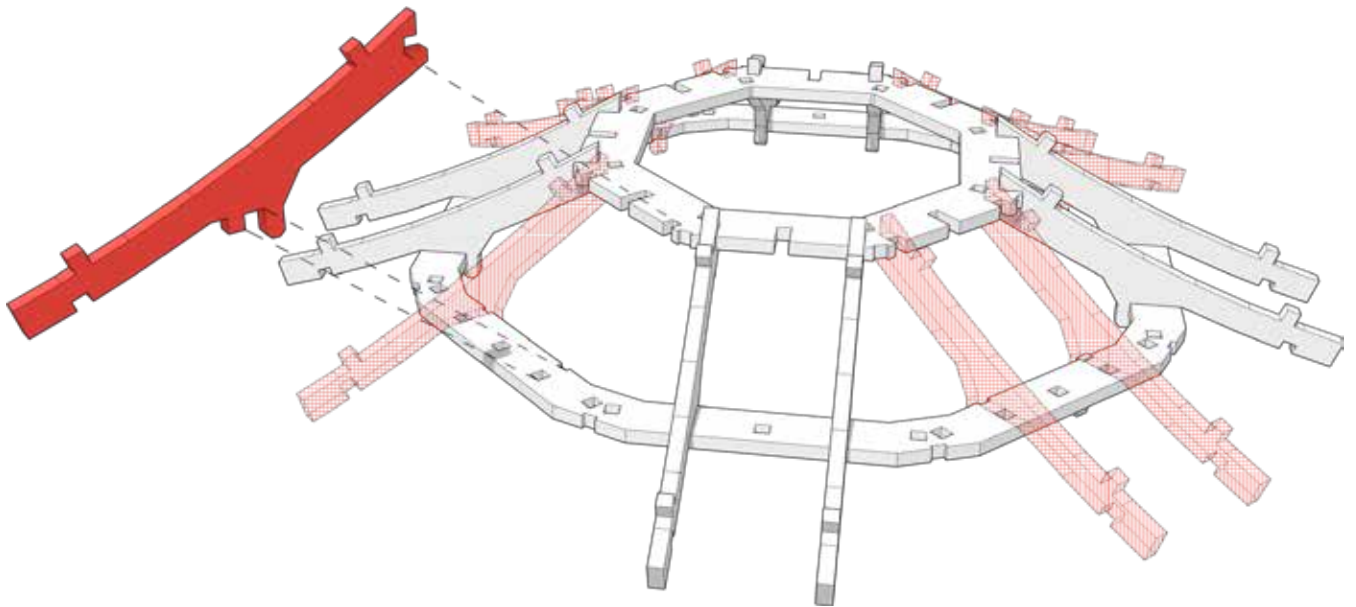



TABLETOP SCENICS

226

TTSCW-EES-110
Toshi
Hakkei-tō Pagoda

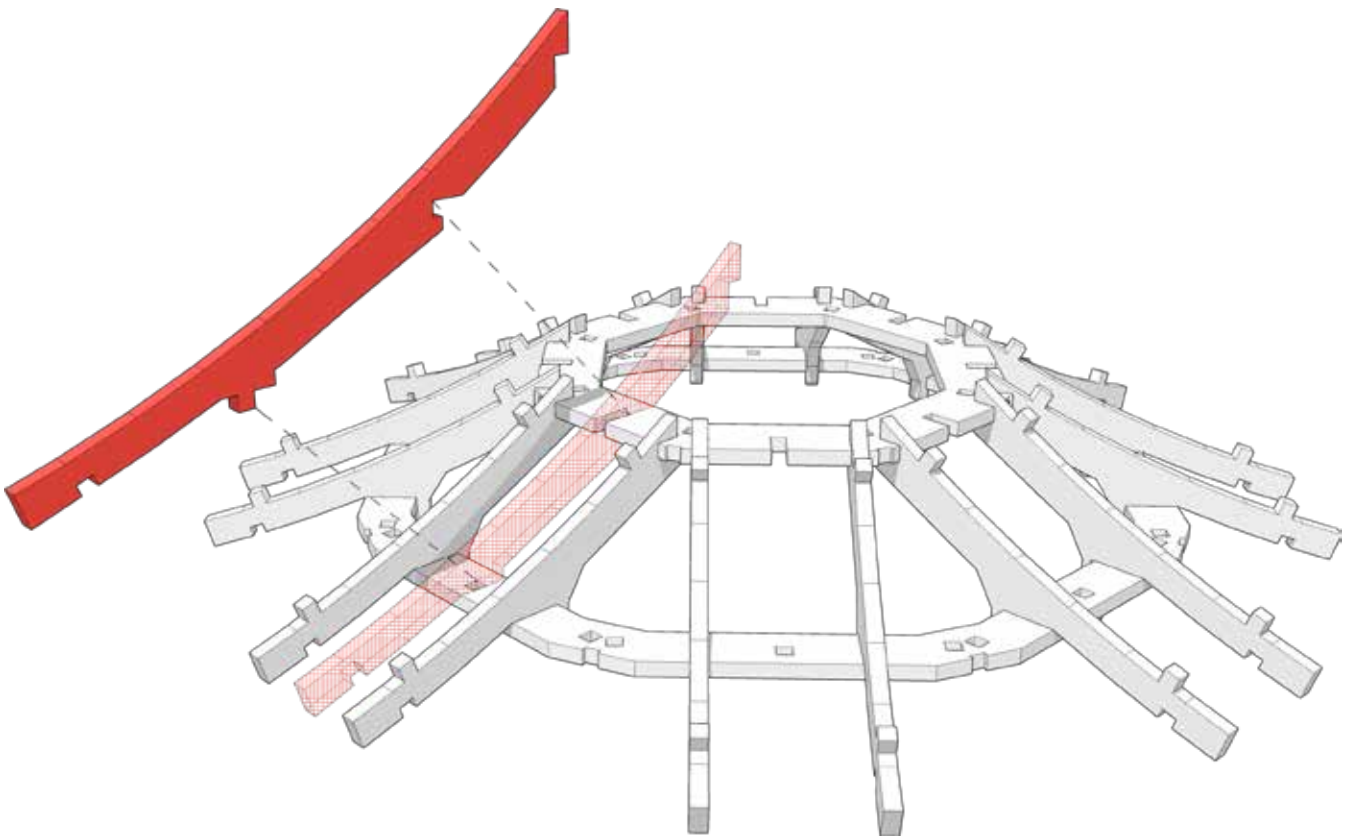

Align the top slot first and the bottom tab can be pushed into place. This will likely push the lower ring out of the parts from the existing steps so beware to push back into place before it dries



 **TTCOMBAT**



TABLETOP SCENICS

227

TTSCW-EES-110
Toshi
Hakkei-tō Pagoda

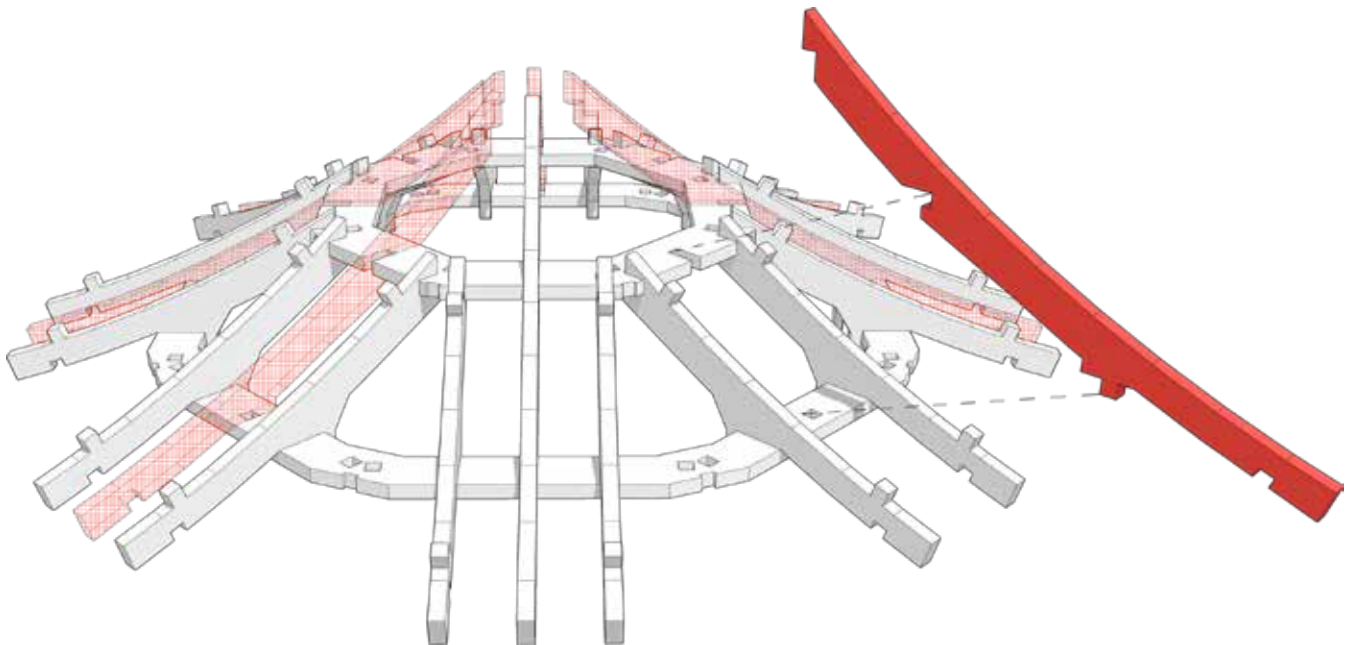



TABLETOP SCENICS

228

TTSCW-EES-110
Toshi
Hakkei-tō Pagoda

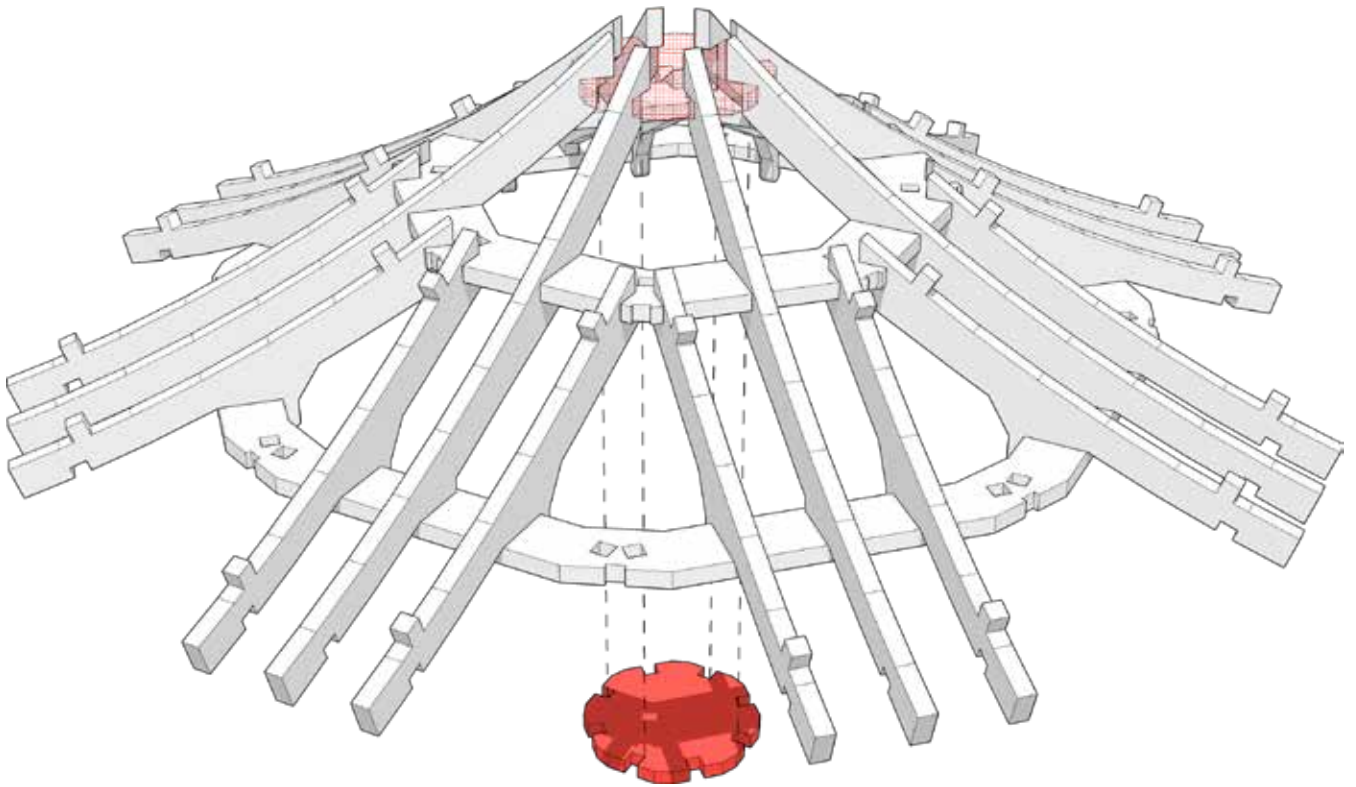



TABLETOP SCENICS

229

TTSCW-EES-110
Toshi
Hakkei-tō Pagoda

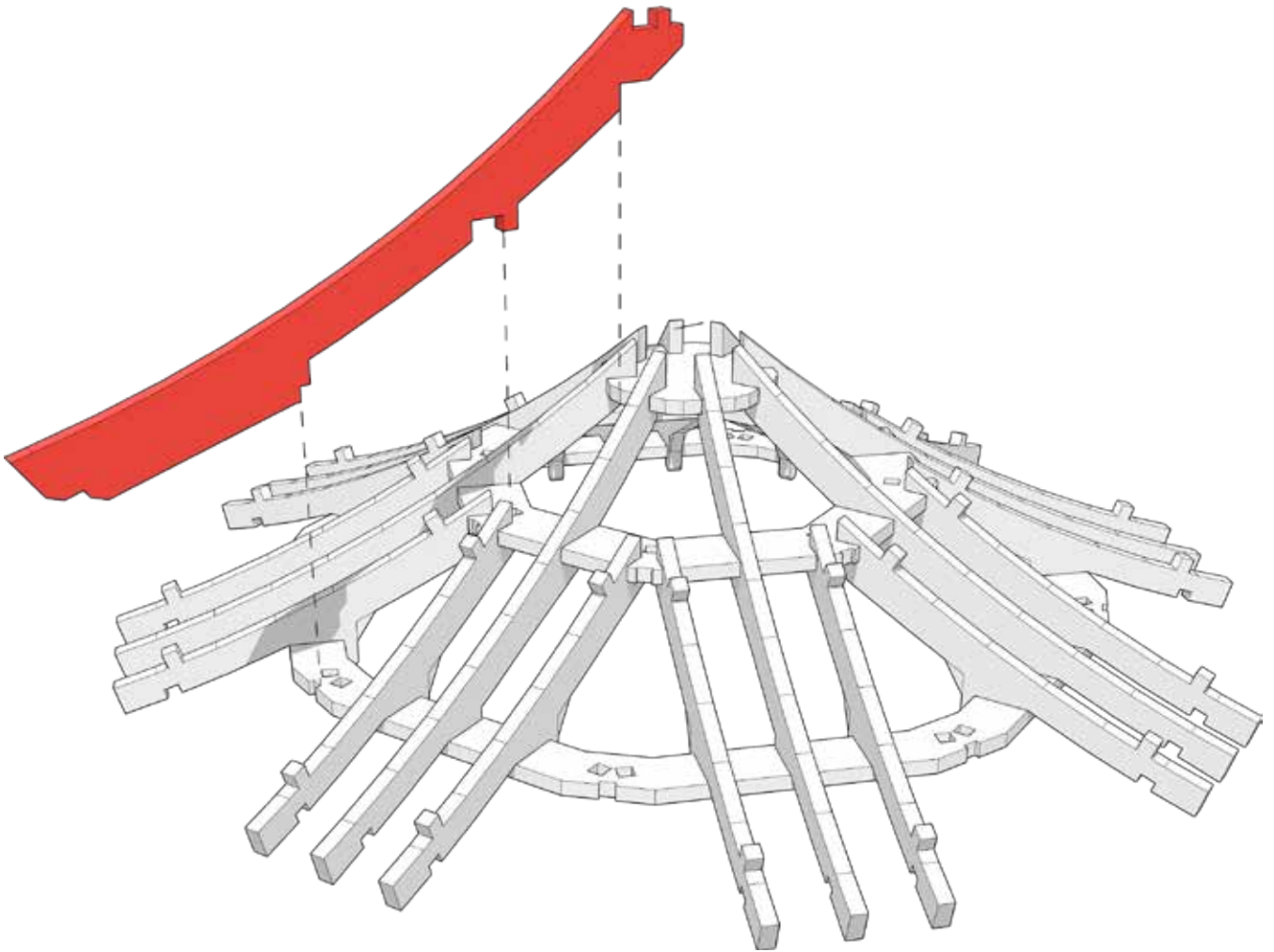



TABLETOP SCENICS

230

TTSCW-EES-110
Toshi
Hakkei-tō Pagoda

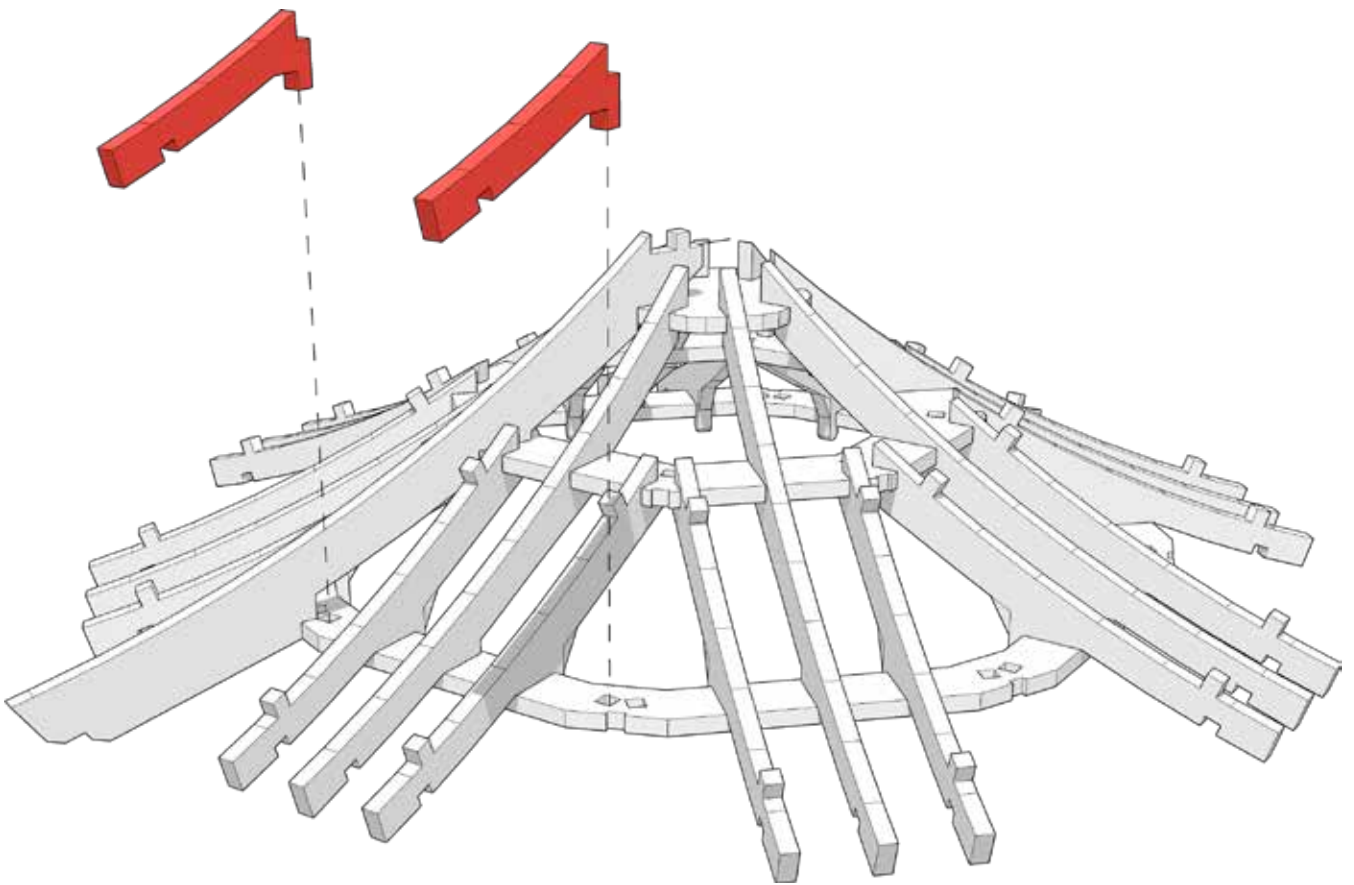



TABLETOP SCENICS

231

TTSCW-EES-110
Toshi
Hakkei-tō Pagoda

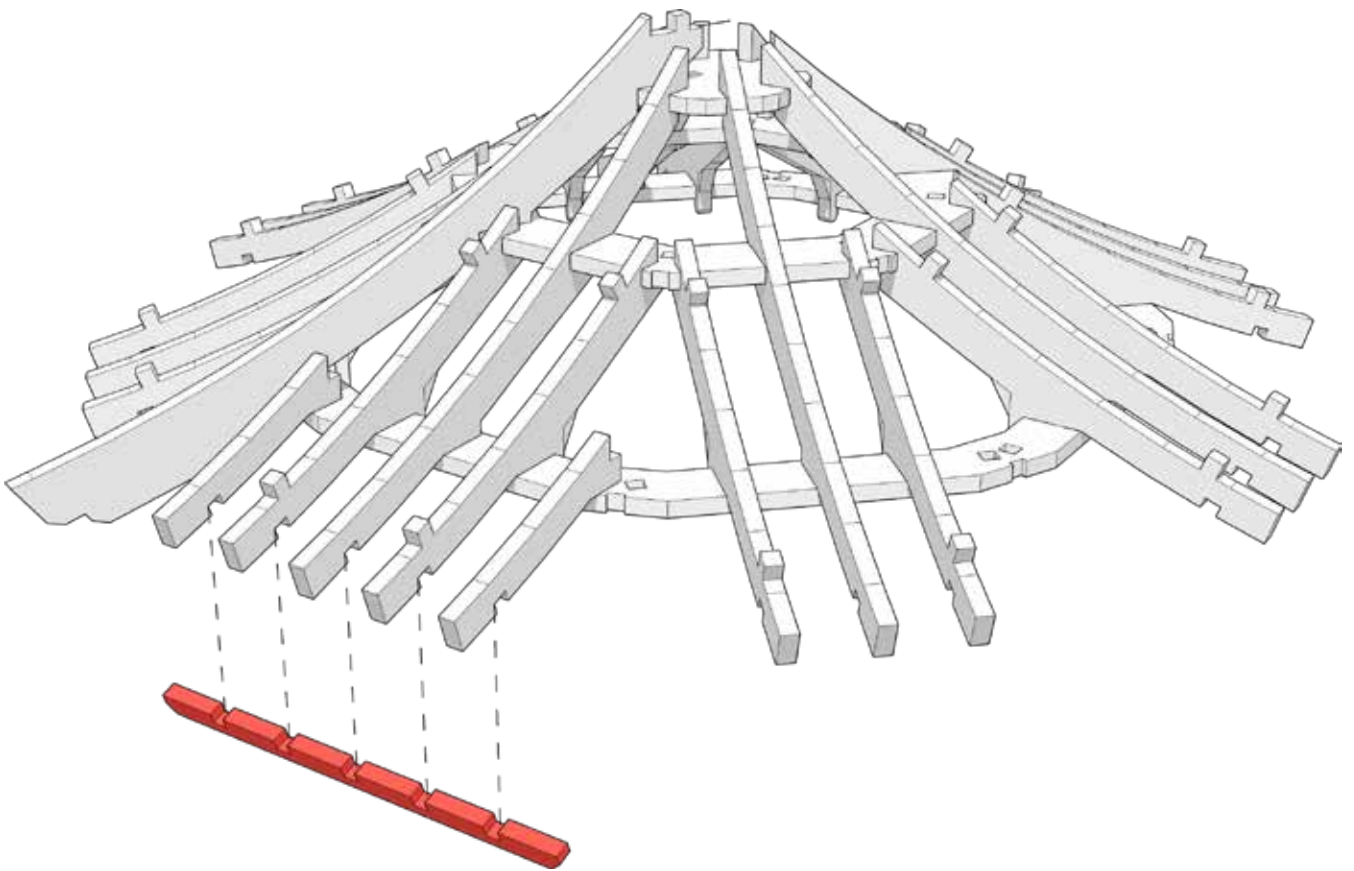



TABLETOP SCENICS

232

TTSCW-EES-110
Toshi
Hakkei-tō Pagoda

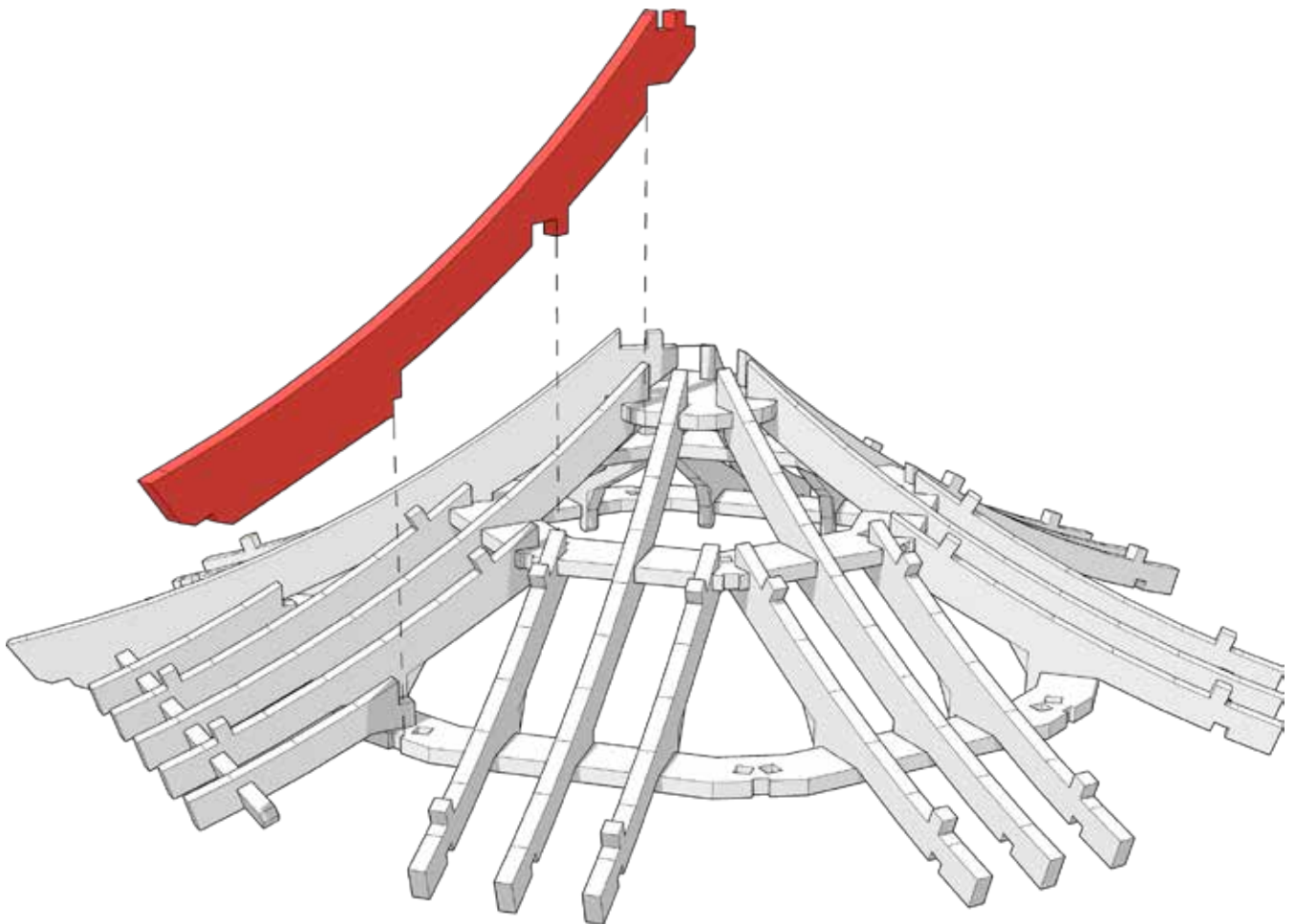

Repeat steps 195 - 197 around the roof structure



TABLETOP SCENICS

233

TTSCW-EES-110
Toshi
Hakkei-tō Pagoda

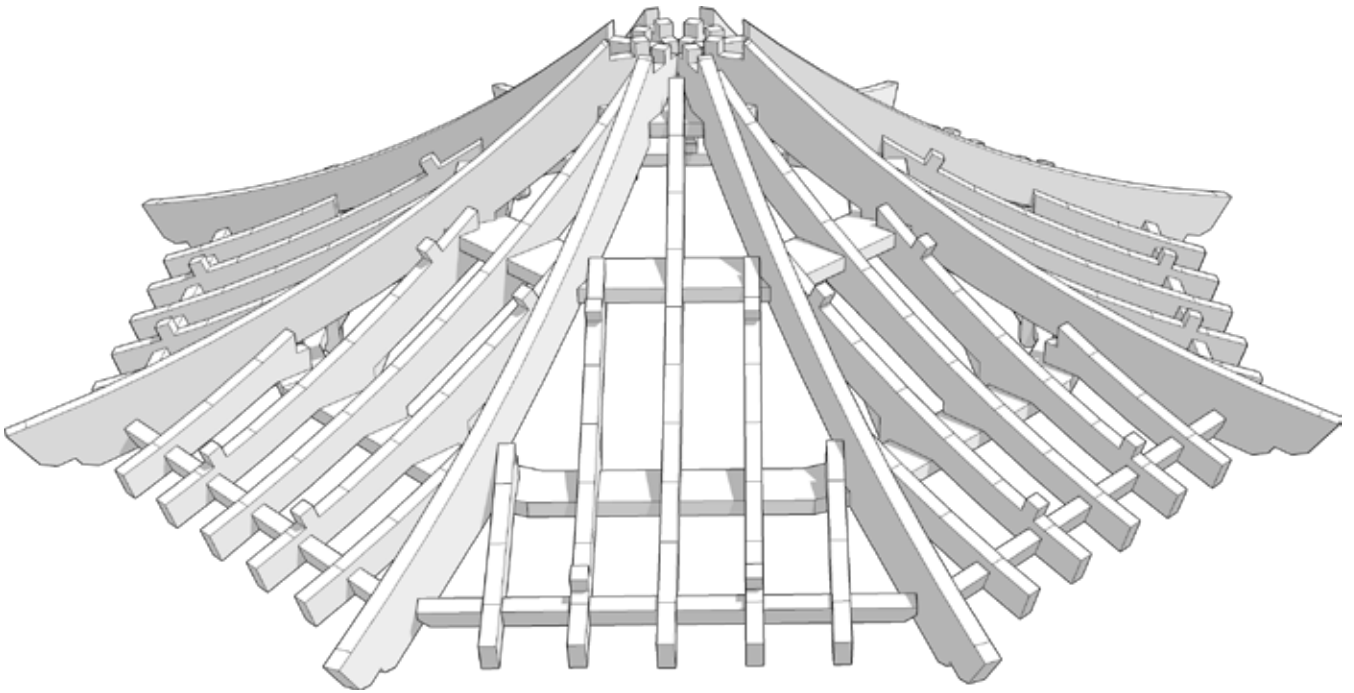



TABLETOP
SCENICS

TTSCW-EES-110
Toshi
Hakkei-tō Pagoda

234

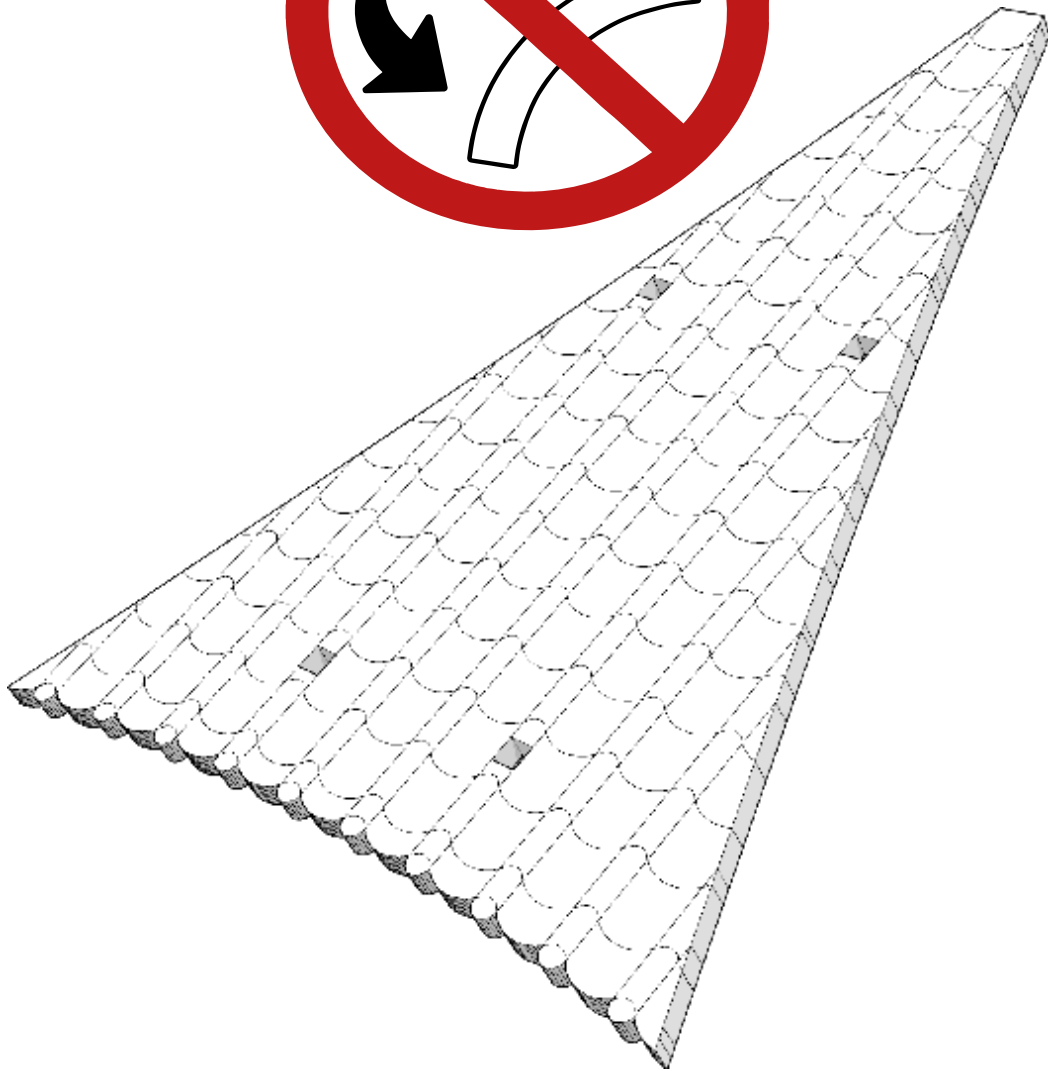

FRAGILE

Over bending will cause this to break
Do not bend freely



TABLETOP SCENICS

235

TTSCW-EES-110
Toshi
Hakkei-tō Pagoda

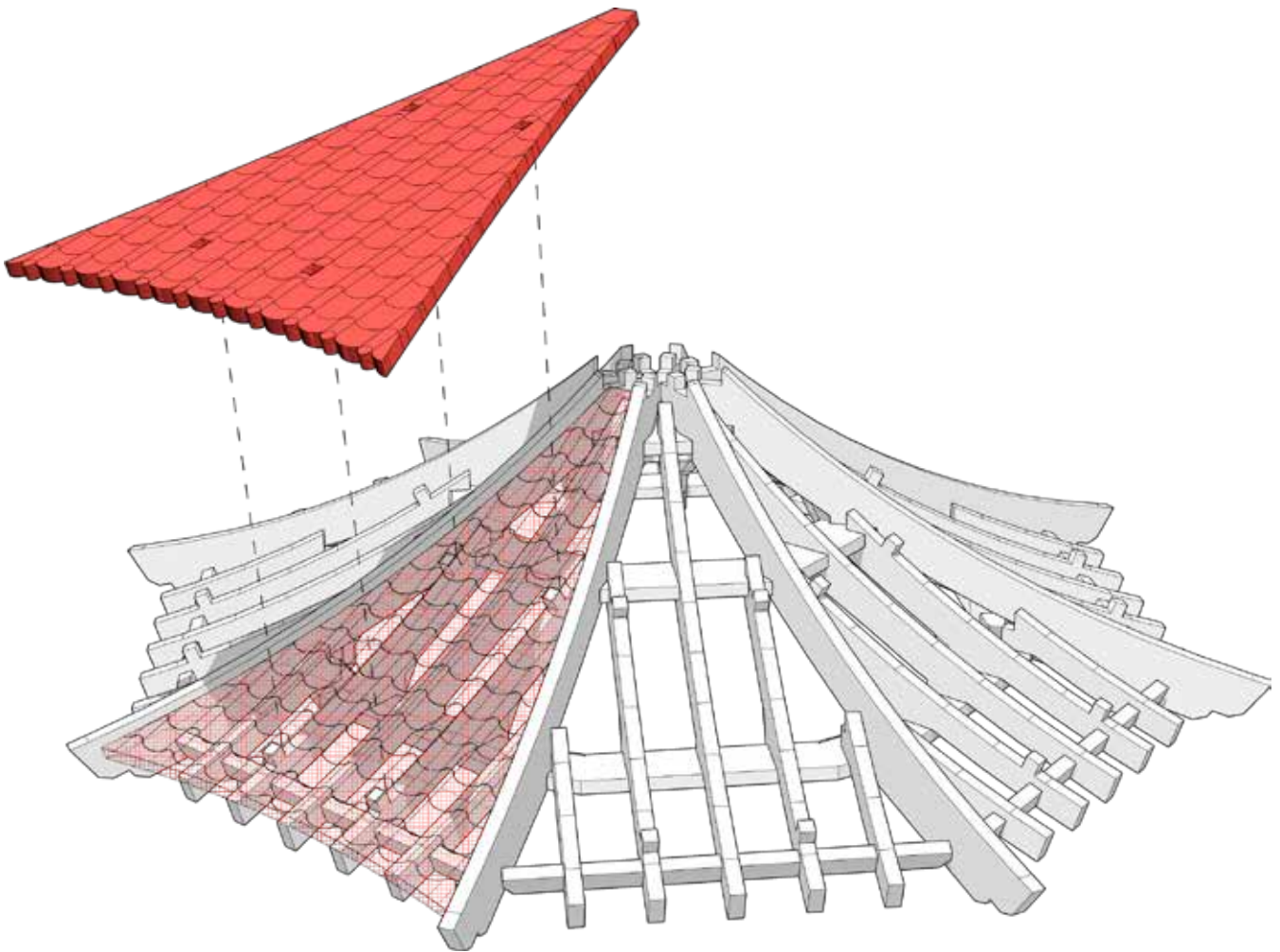

Align the top tabs and gently press down to slot into place, working down to the next tabs, roof should bend into place. Superglue is recommended as it dries quickly



 **TTCOMBAT**



TABLETOP SCENICS

236

TTSCW-EES-110
Toshi
Hakkei-tō Pagoda

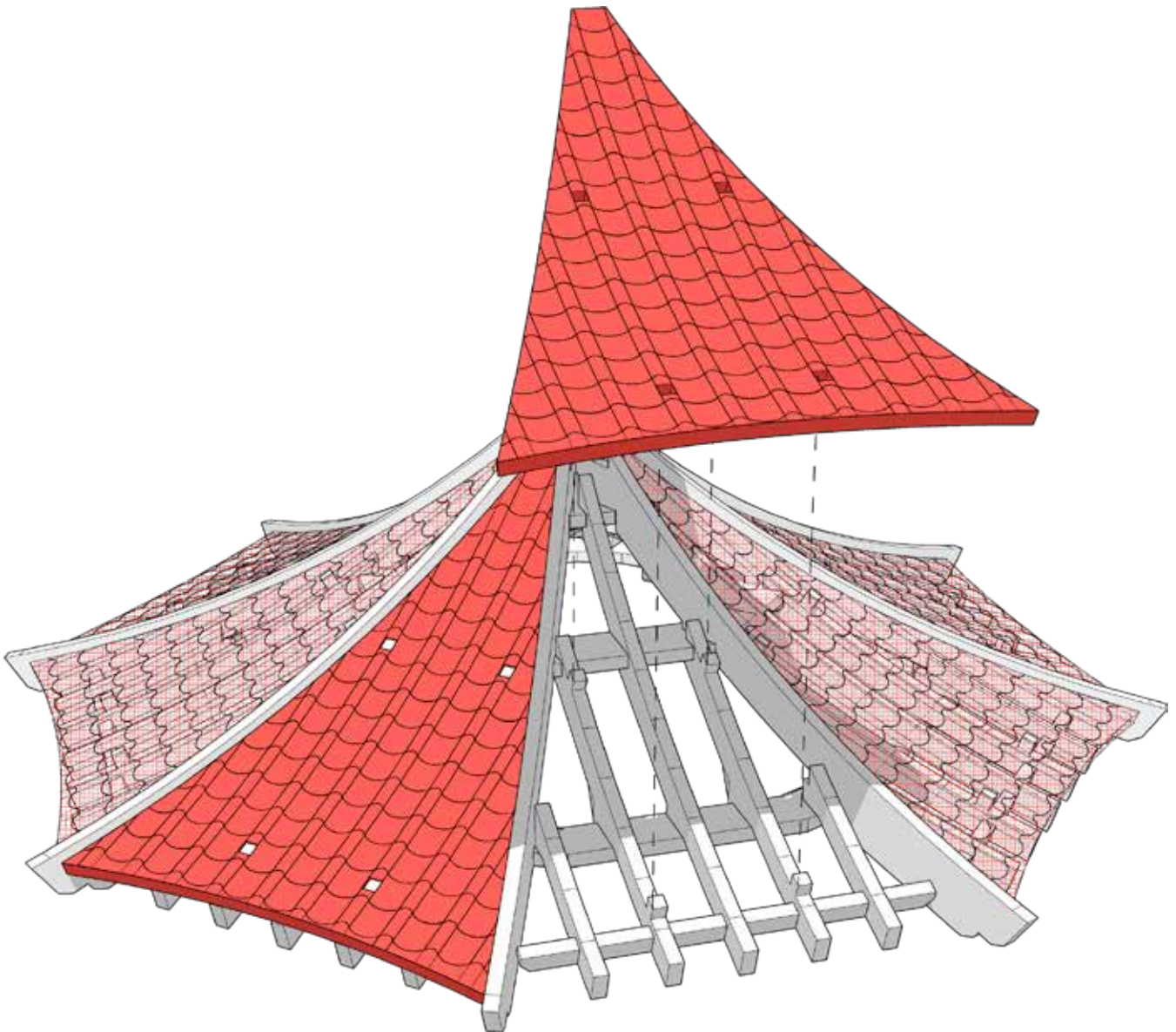

Repeat adding panels around the roof. Take time to make sure they've dried into place before moving the next





TABLETOP
SCENICS

237

TTSCW-EES-110
Toshi
Hakkei-tō Pagoda

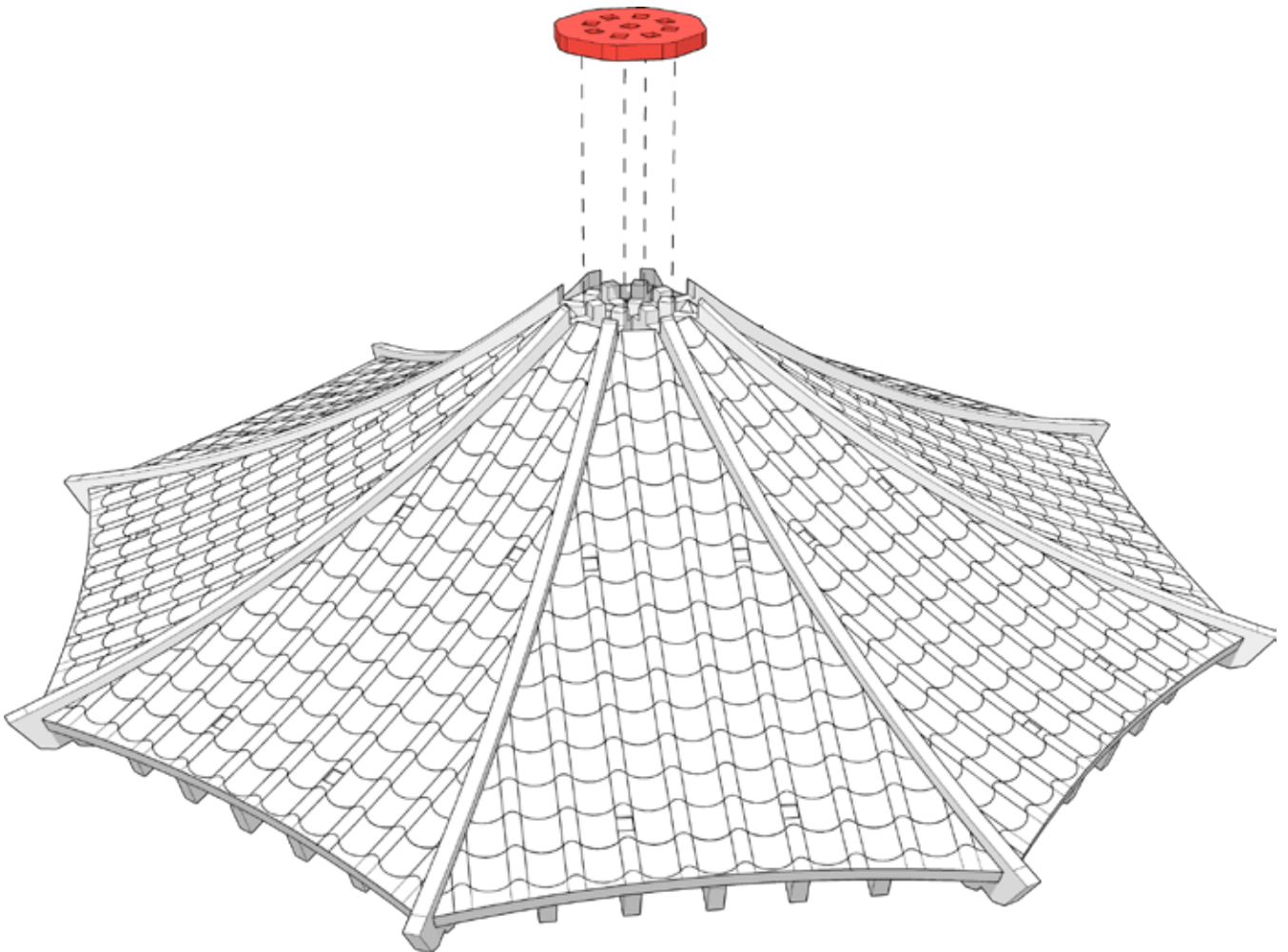



TABLETOP SCENICS

238

TTSCW-EES-110
Toshi
Hakkei-tō Pagoda

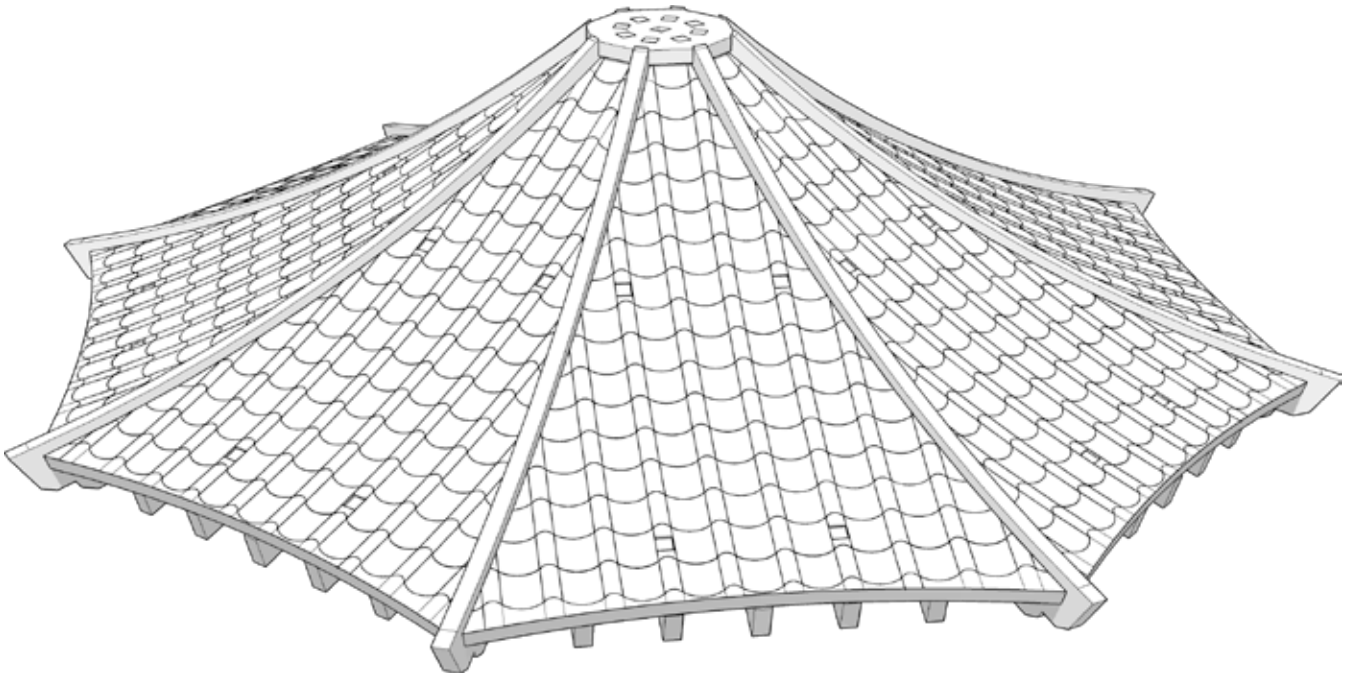



TABLETOP SCENICS

TTSCW-EES-110
Toshi
Hakkei-tō Pagoda

239

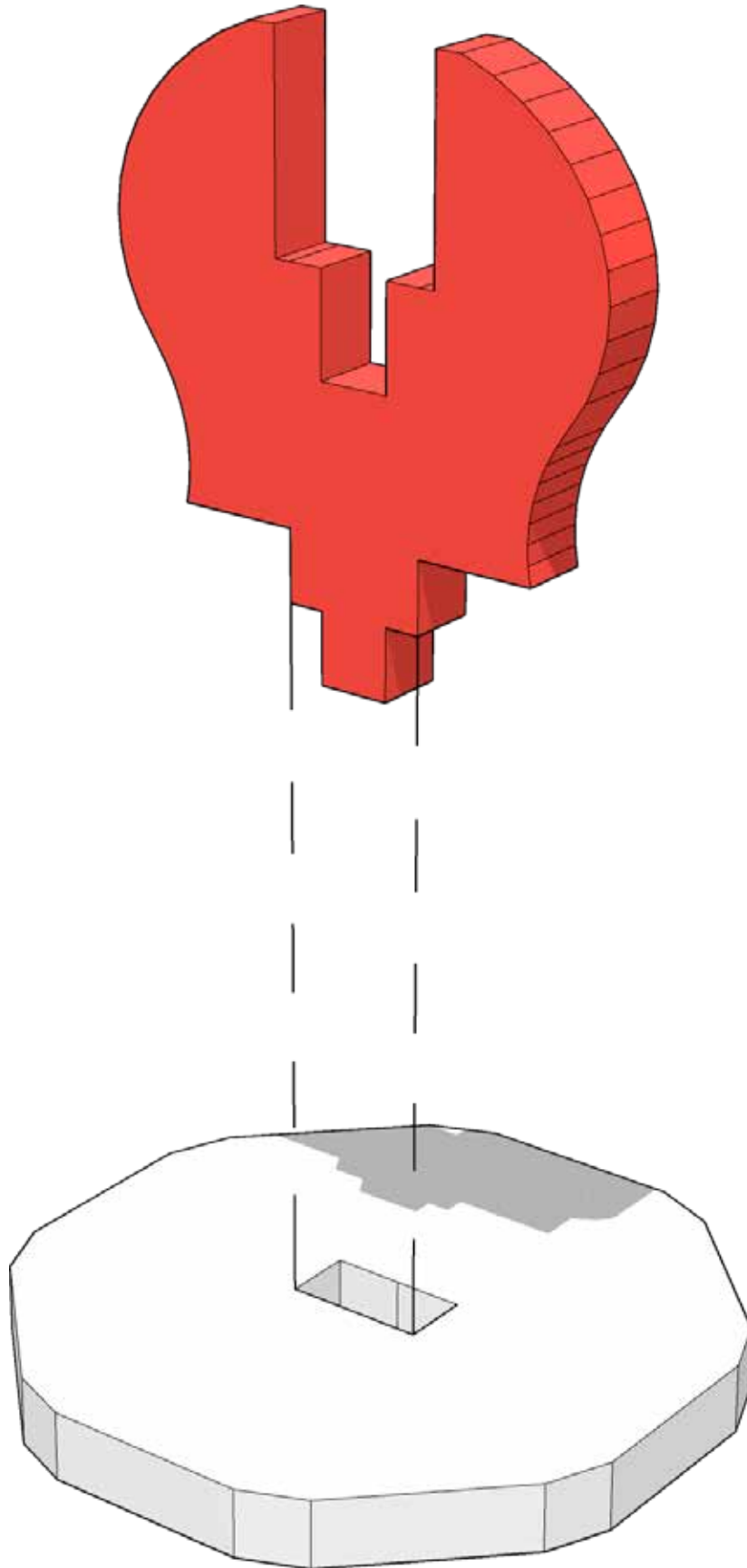



TABLETOP SCENICS

TTSCW-EES-110
Toshi
Hakkei-tō Pagoda

240

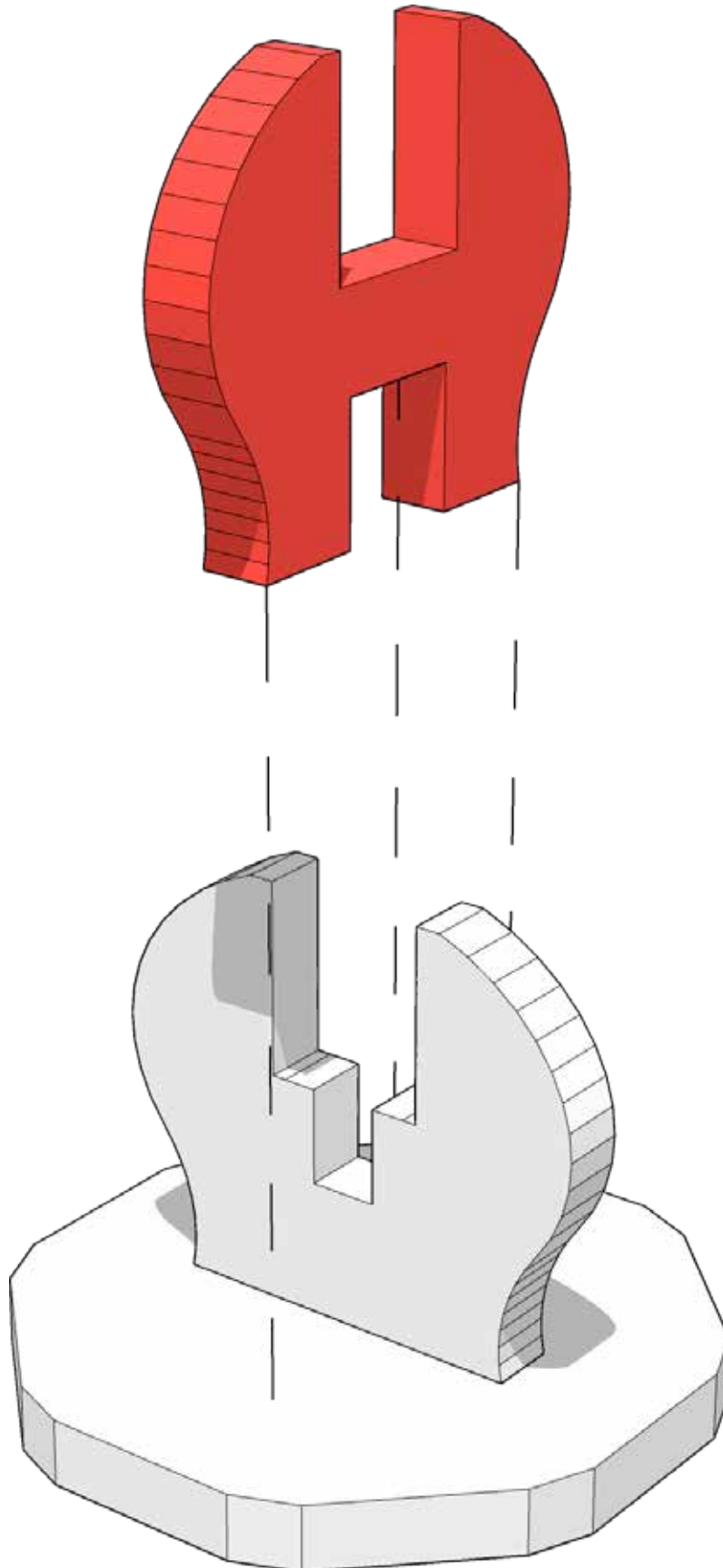



TABLETOP SCENICS

TTSCW-EES-110
Toshi
Hakkei-tō Pagoda

241

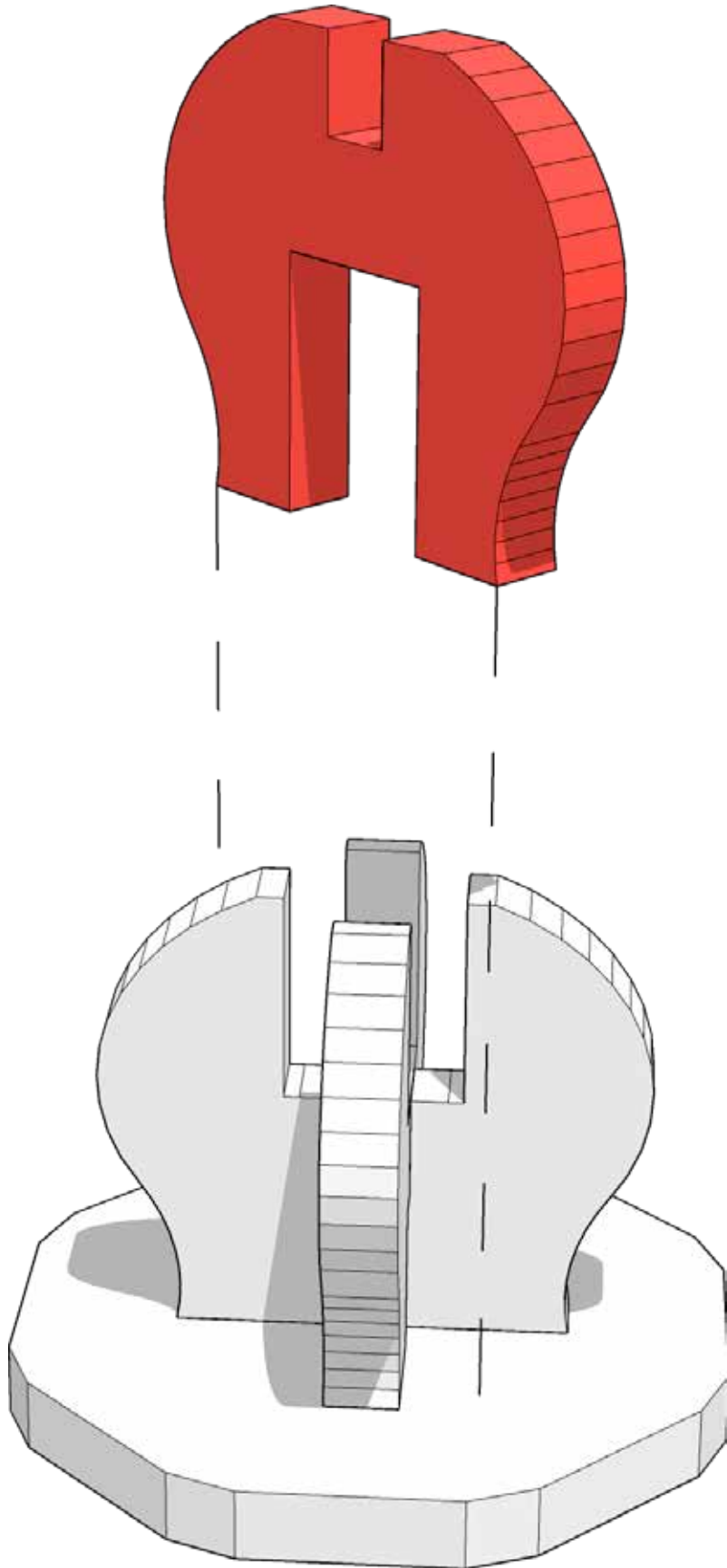



TABLETOP SCENICS

TTSCW-EES-110
Toshi
Hakkei-tō Pagoda

242

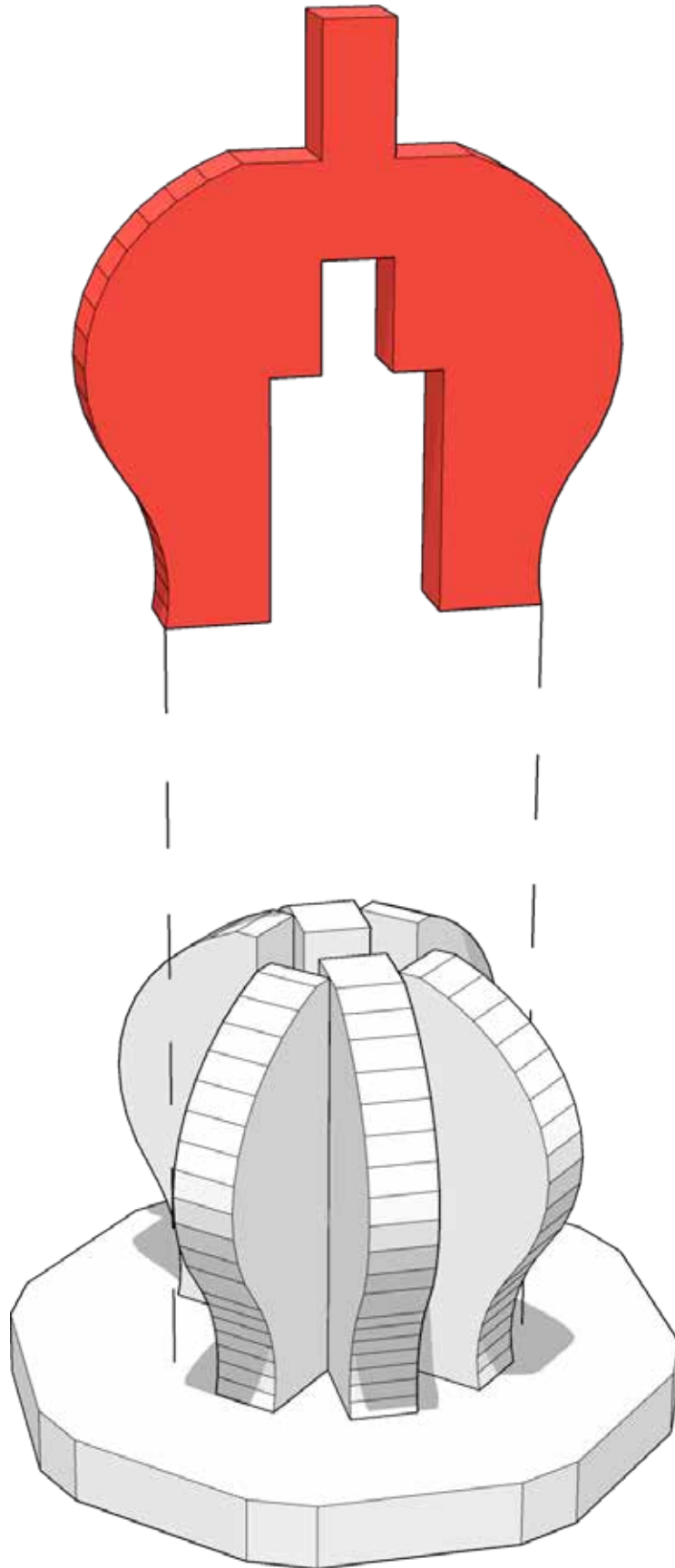



TABLETOP SCENICS

TTSCW-EES-110
Toshi
Hakkei-tō Pagoda

243

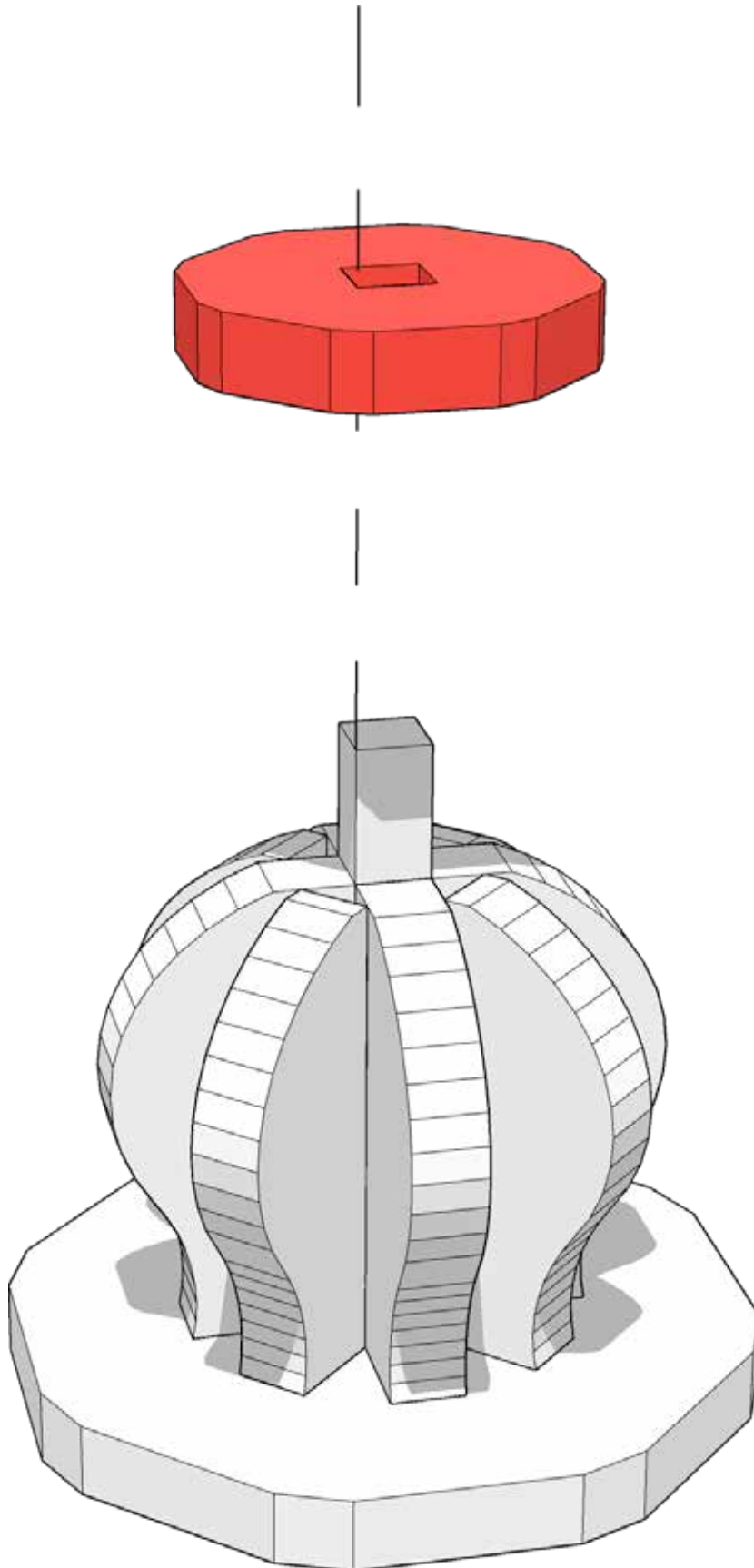



TABLETOP SCENICS

TTSCW-EES-110
Toshi
Hakkei-tō Pagoda

244

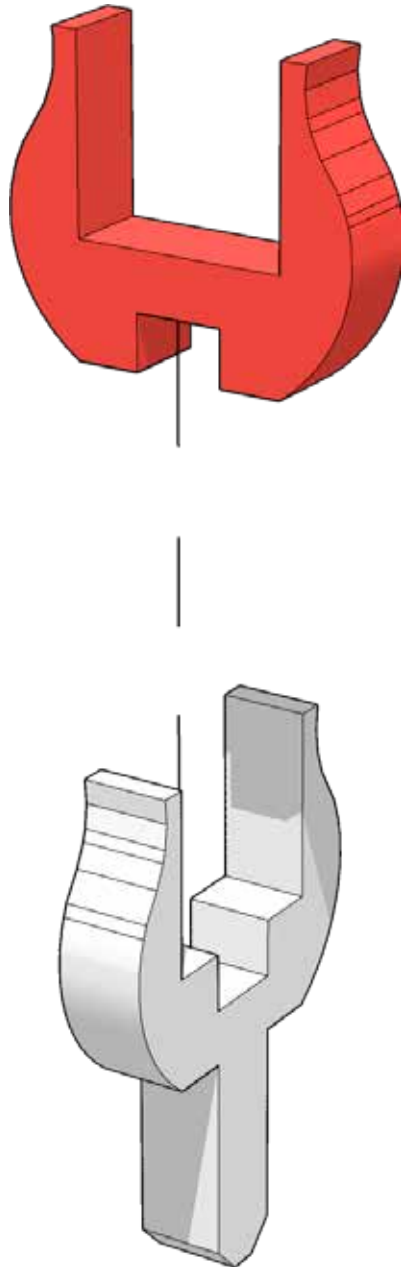



TABLETOP SCENICS

245

TTSCW-EES-110
Toshi
Hakkei-tō Pagoda

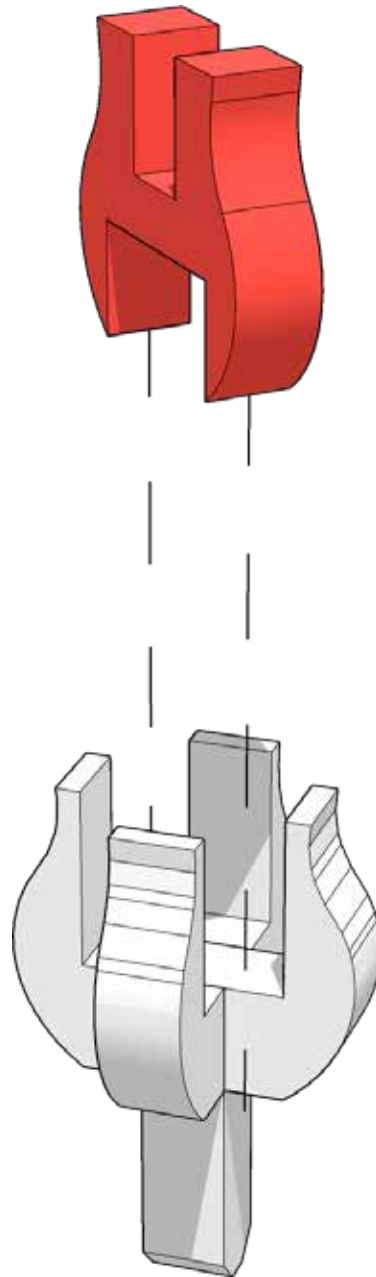



TABLETOP SCENICS

246

TTSCW-EES-110
Toshi
Hakkei-tō Pagoda

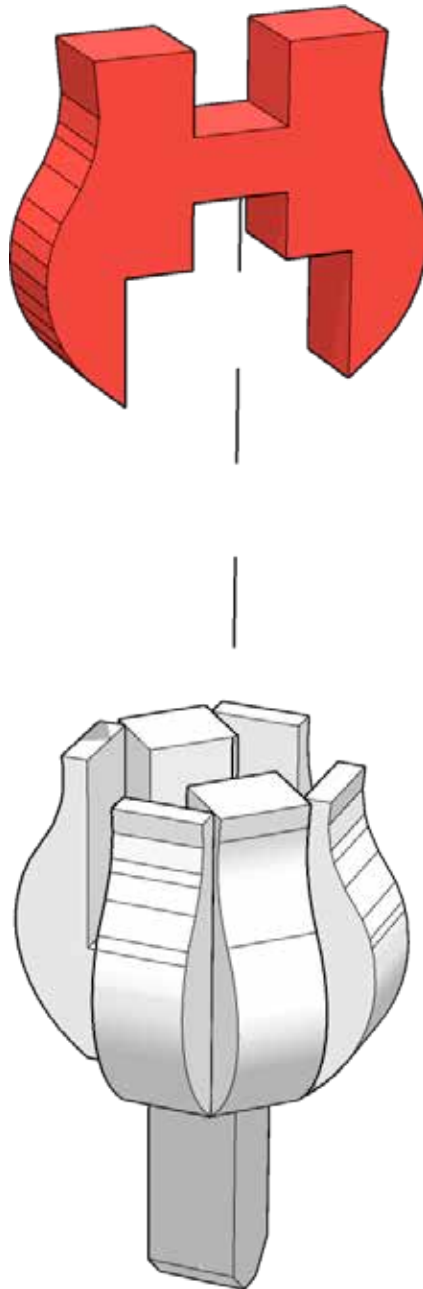



TABLETOP SCENICS

TTSCW-EES-110
Toshi
Hakkei-tō Pagoda

247

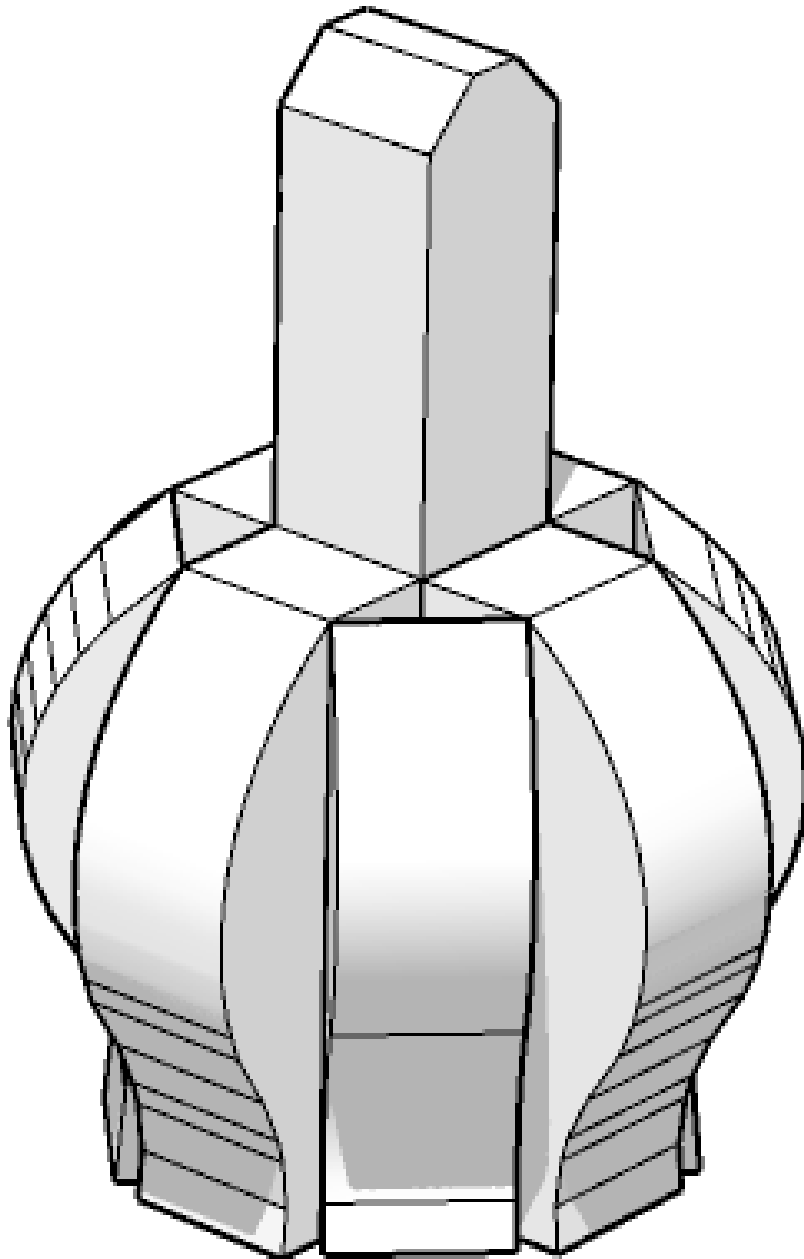



TABLETOP SCENICS

TTSCW-EES-110
Toshi
Hakkei-tō Pagoda

248

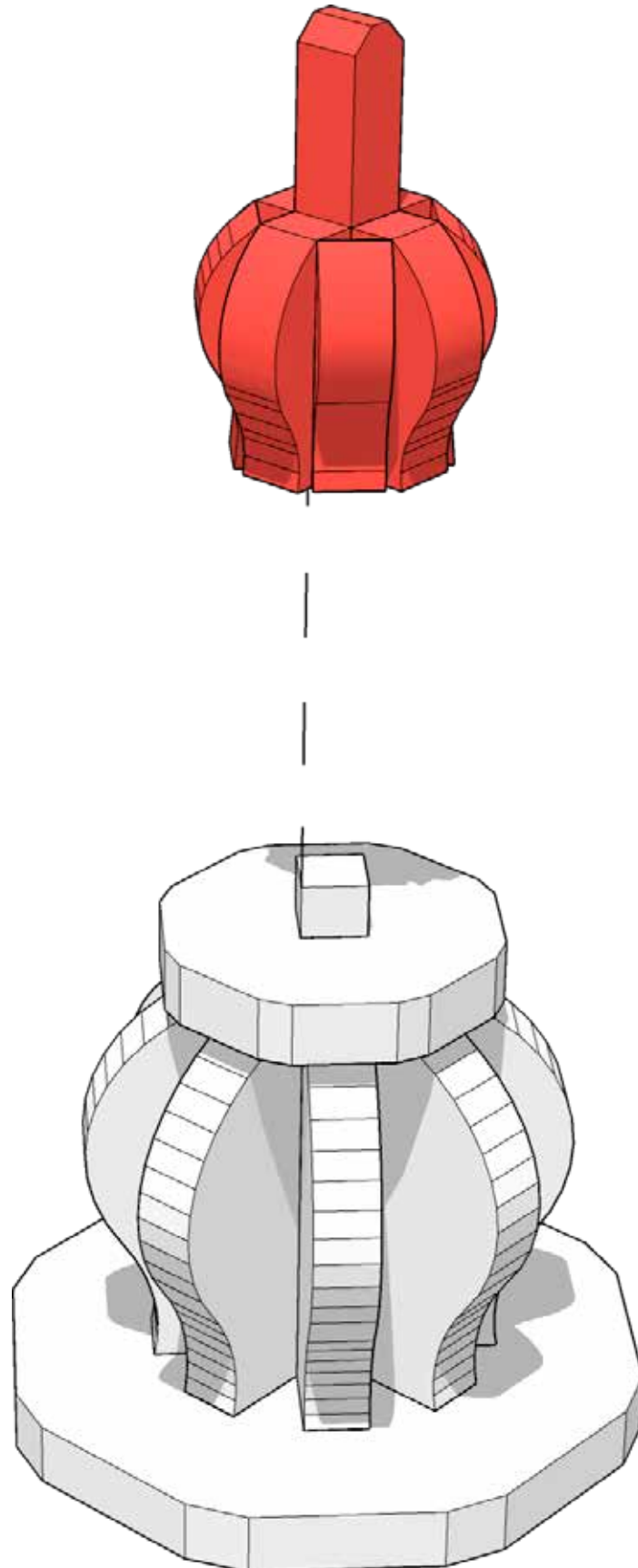



TABLETOP SCENICS

TTSCW-EES-110
Toshi
Hakkei-tō Pagoda

249

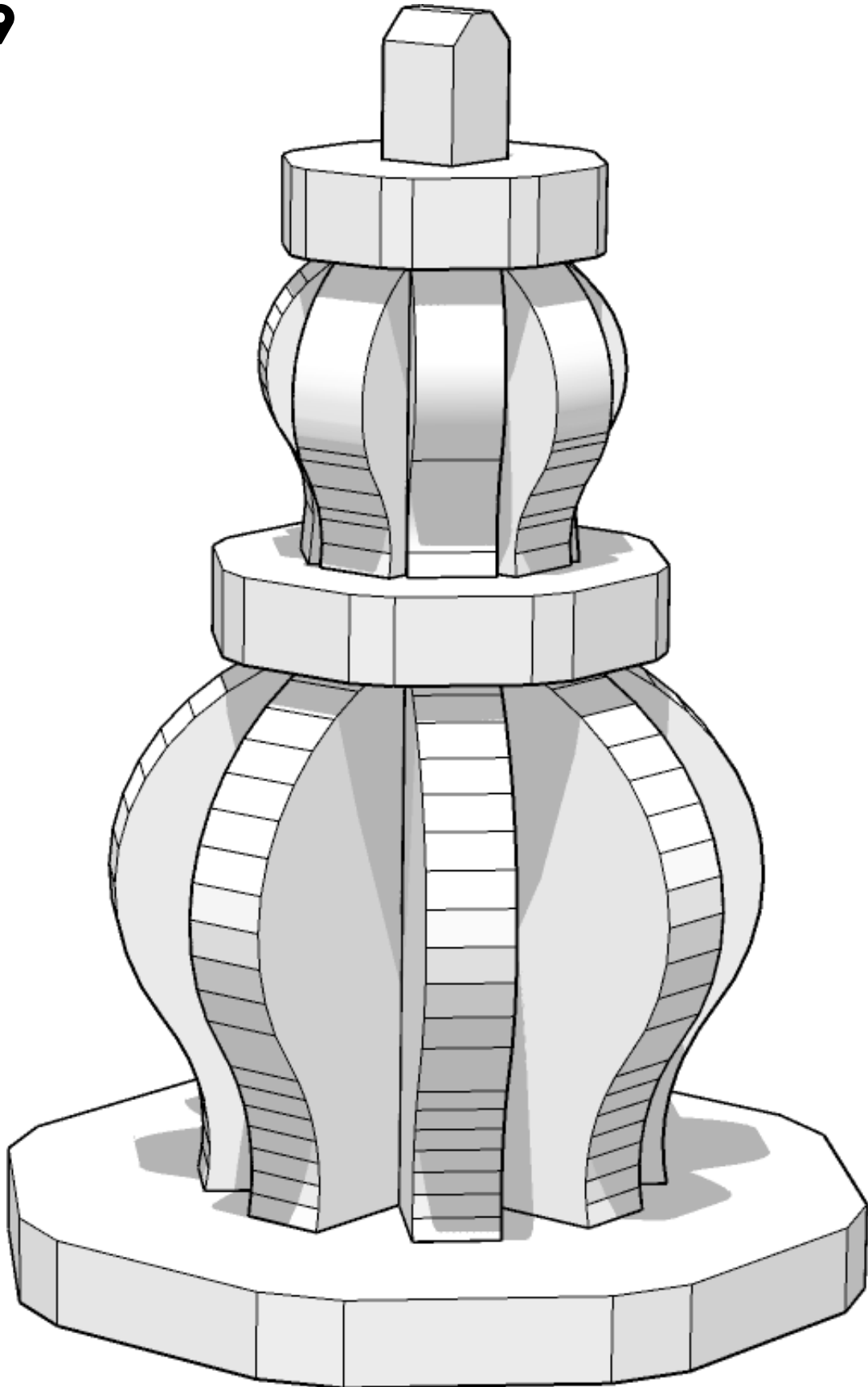



TABLETOP
SCENICS

250

TTSCW-EES-110
Toshi
Hakkei-tō Pagoda

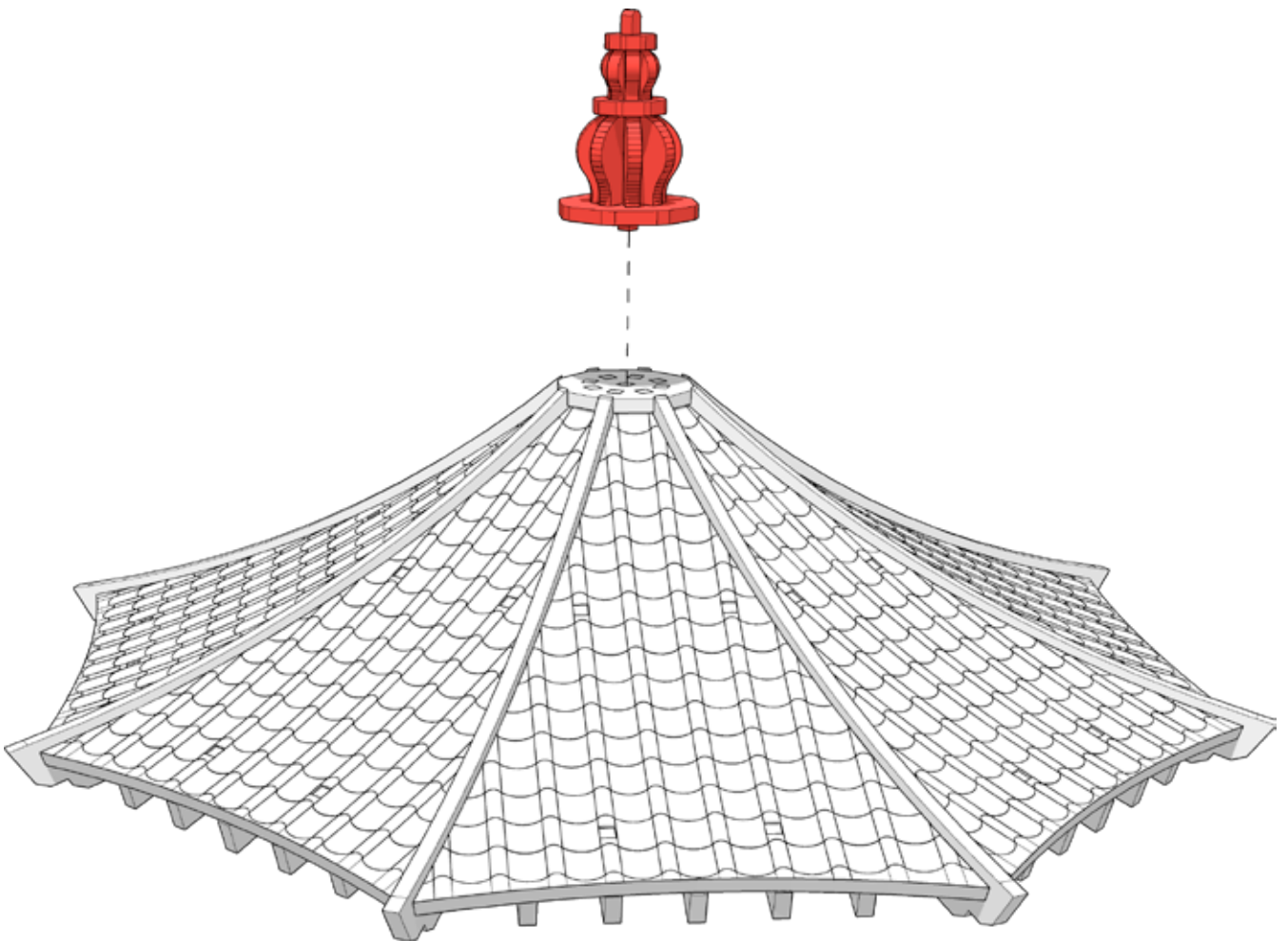



TABLETOP SCENICS

251

TTSCW-EES-110
Toshi
Hakkei-tō Pagoda

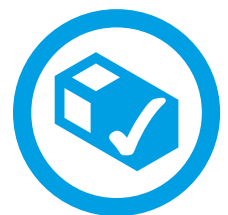
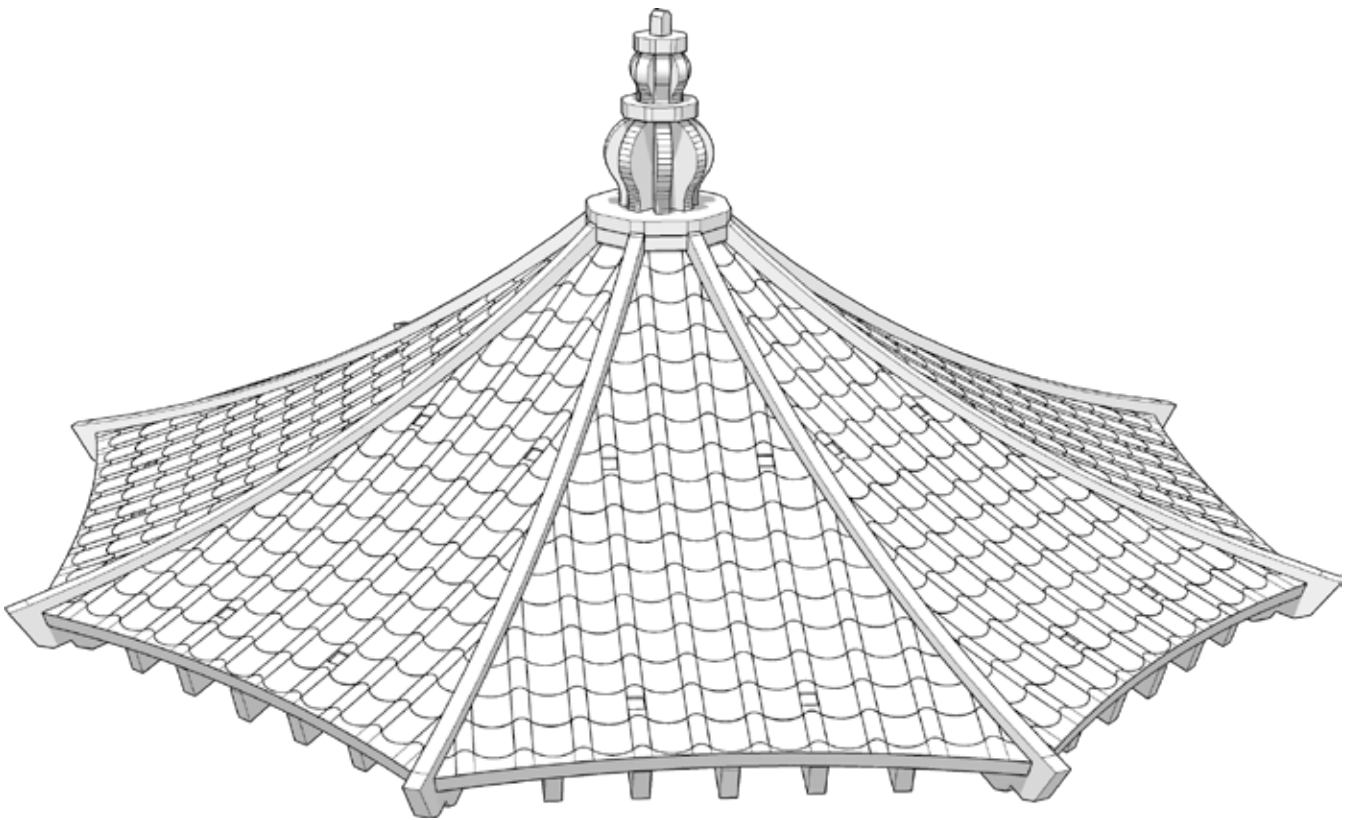

 TTCOMBAT



TABLETOP SCENICS

252

TTSCW-EES-110
Toshi
Hakkei-tō Pagoda

