

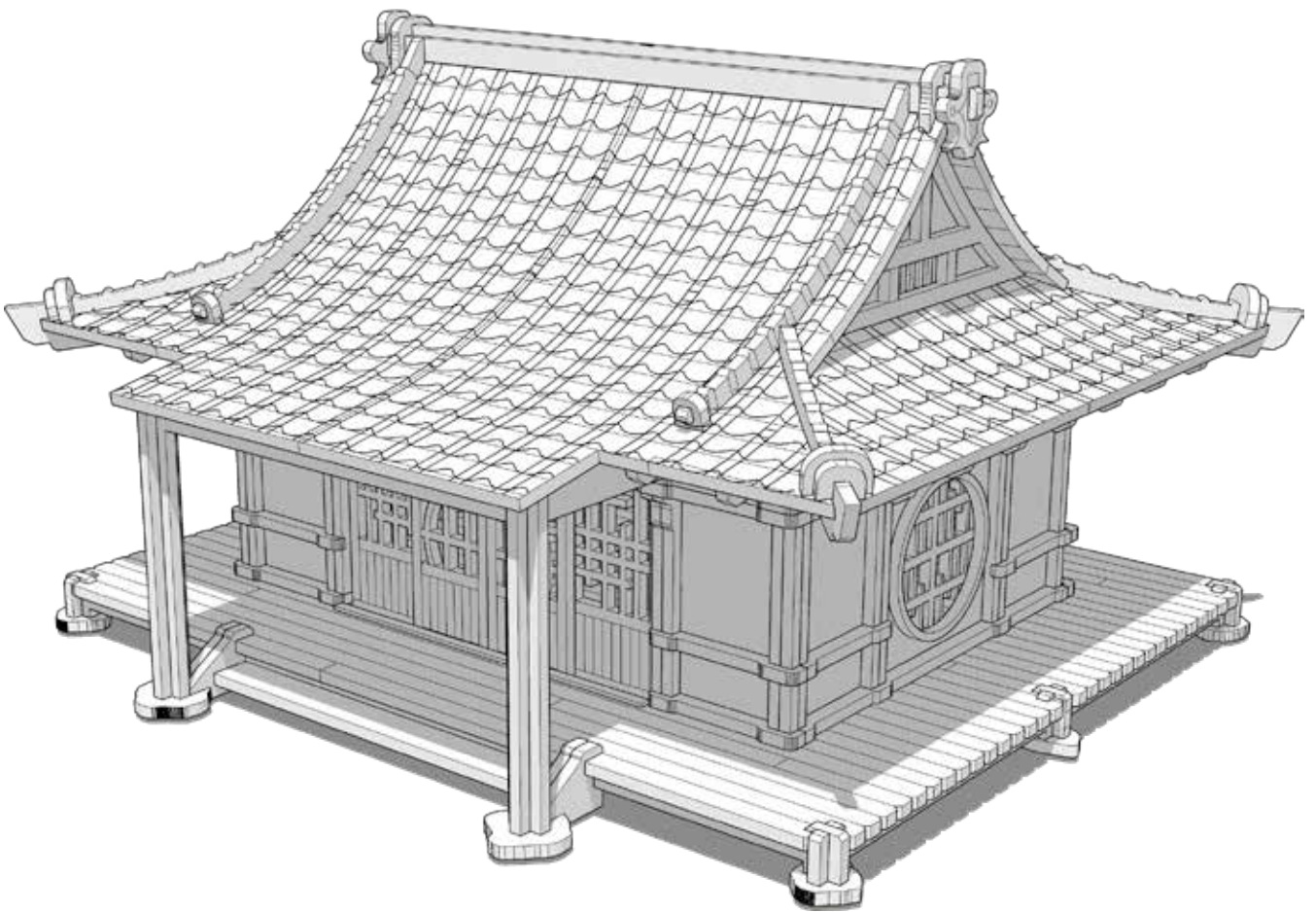

**TABLETOP
SCENICS**

**TTSCW-EES-115
Toshi:
Dojo**



 **TTCOMBAT**



TABLETOP SCENICS

TTSCW-EES-115
Toshi:
Dojo

2

These are a series of icons that may be used throughout the instructions to help your assembly.
If in doubt, scroll ahead to confirm.



Do not glue this part



Carefully score and
fold this part

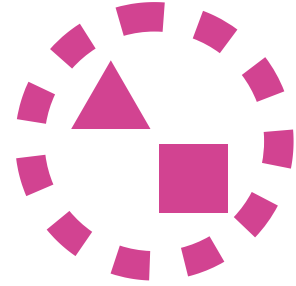

This part - or its placement is
completely optional

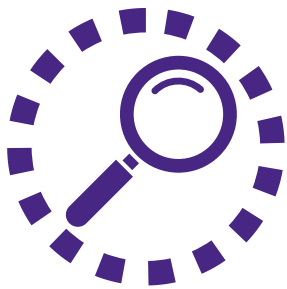

Look closely at this step -
The process order or part
used, may be specific



Repeat making this part
the specified number
of times

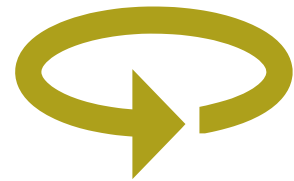

The next instruction step
will be the same assembly
so far, but from a different
angle

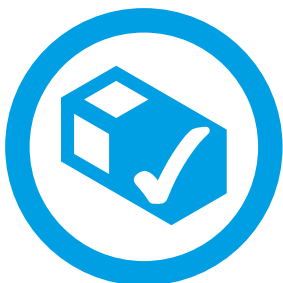

Sub-assembly complete.
This smaller construction
is ready to add to the
main kit



Assembly Complete! There
could be more optional
parts - check to the very end
of instructions



FRAGILE: DO NOT BEND.
“Bendy wood” is designed to
curve around a designed
frame only.



TABLETOP SCENICS

TTSCW-EES-115
Toshi:
Dojo

3

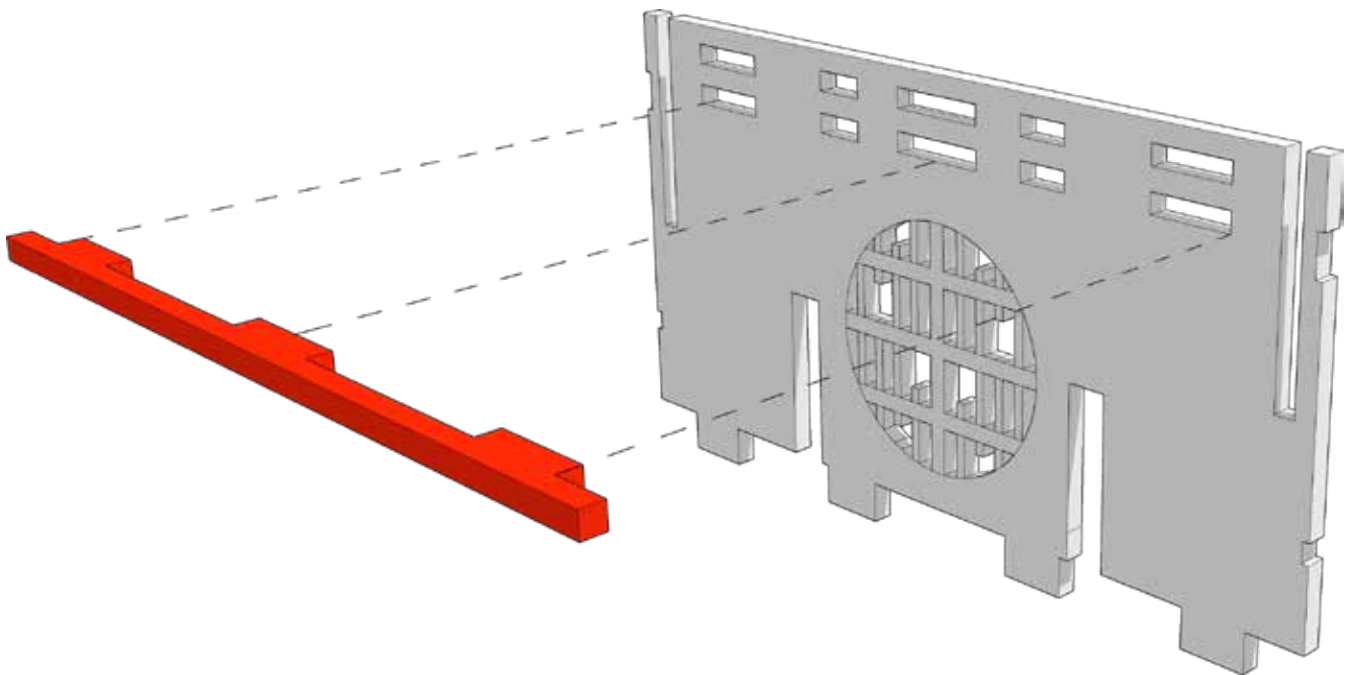



TABLETOP SCENICS

TTSCW-EES-115
Toshi:
Dojo

4

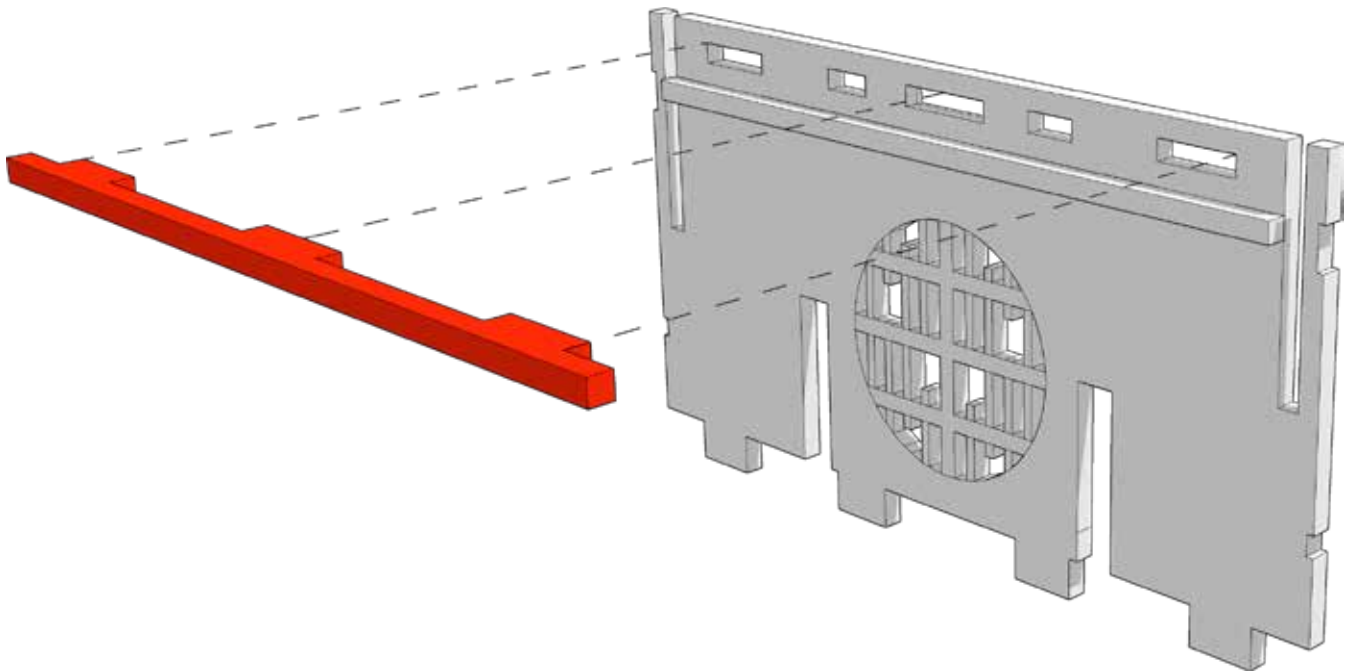



TABLETOP SCENICS

TTSCW-EES-115
Toshi:
Dojo

5

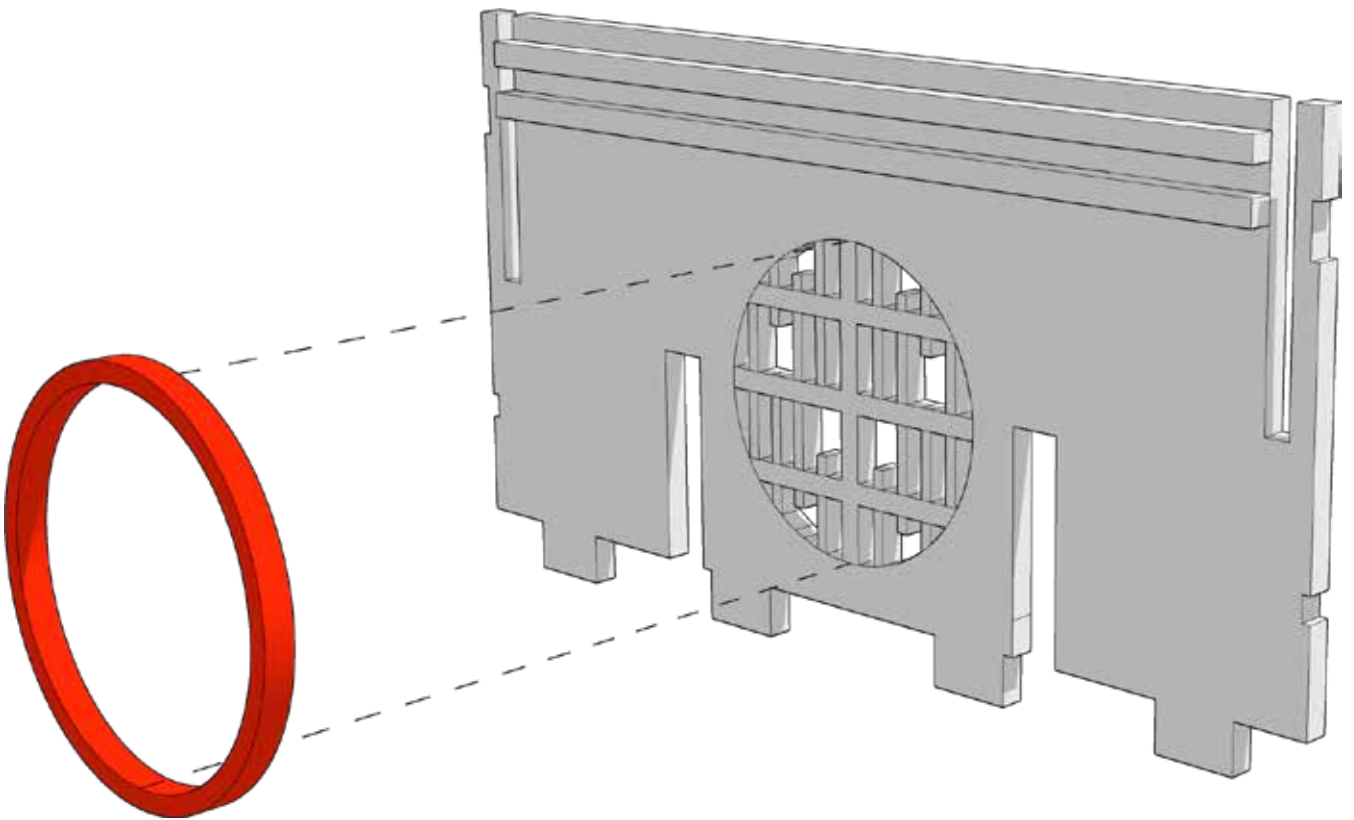



TABLETOP SCENICS

TTSCW-EES-115
Toshi:
Dojo

6

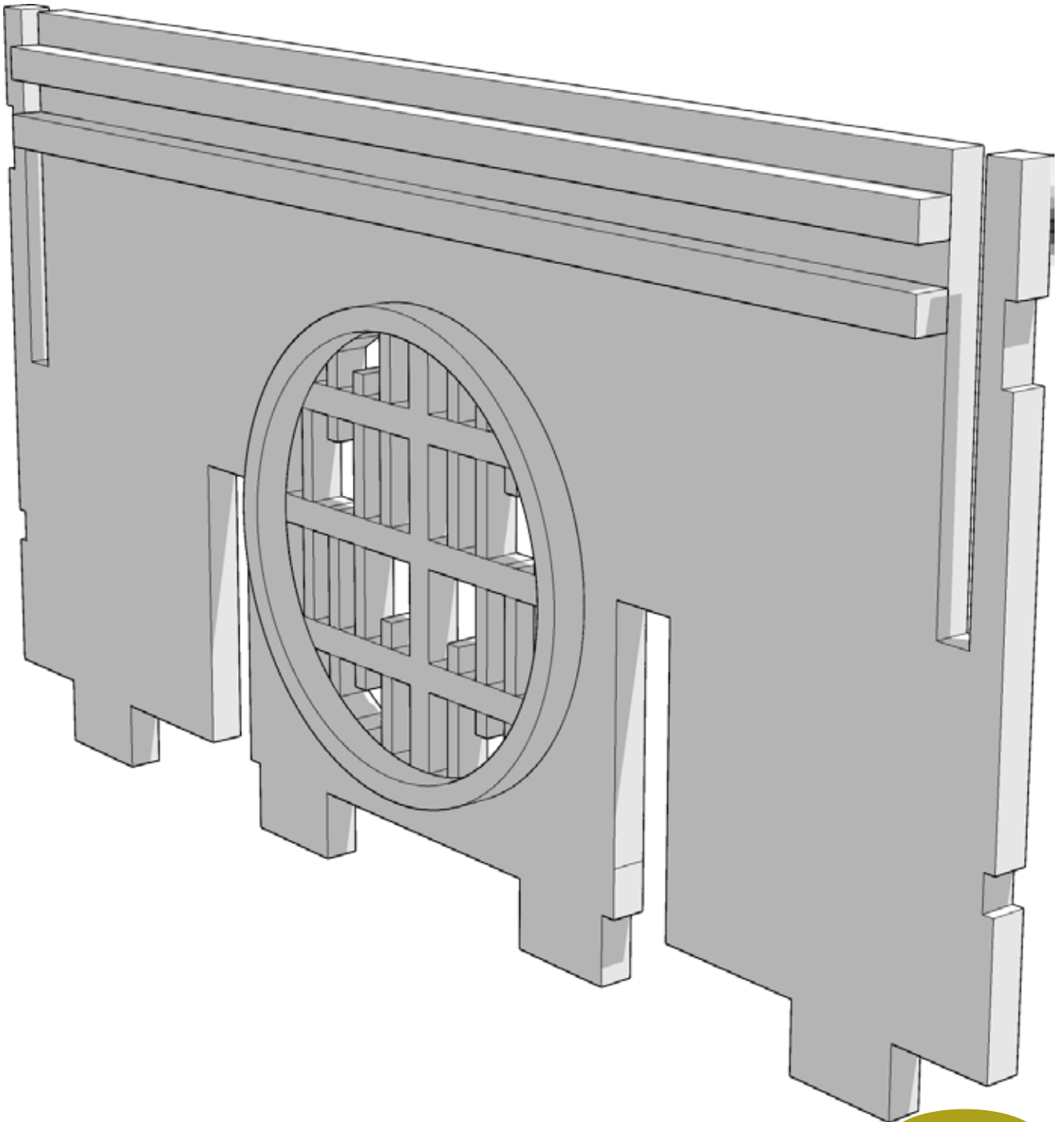



TABLETOP SCENICS

TTSCW-EES-115
Toshi:
Dojo

7

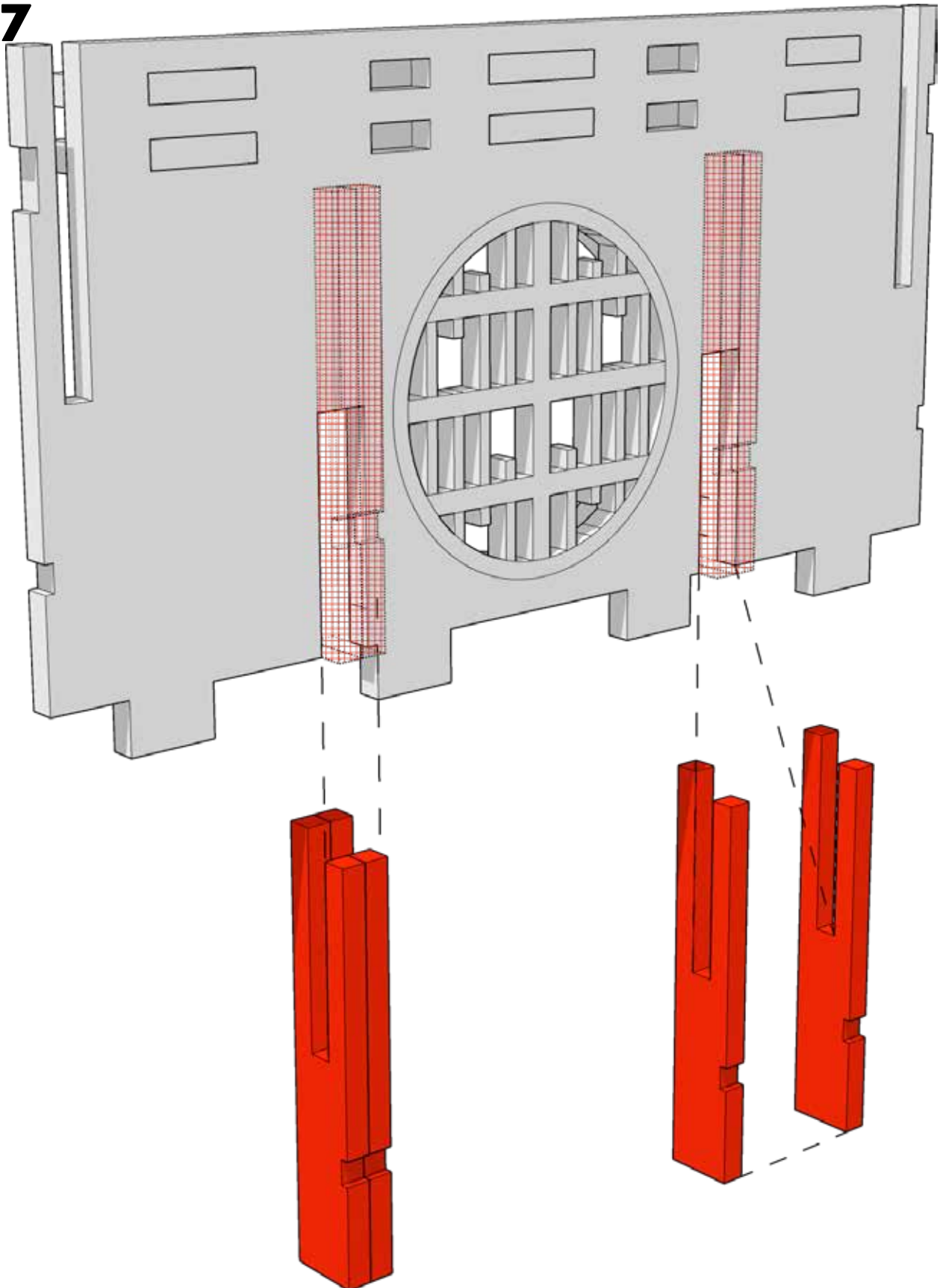



TABLETOP SCENICS

TTSCW-EES-115
Toshi:
Dojo

8

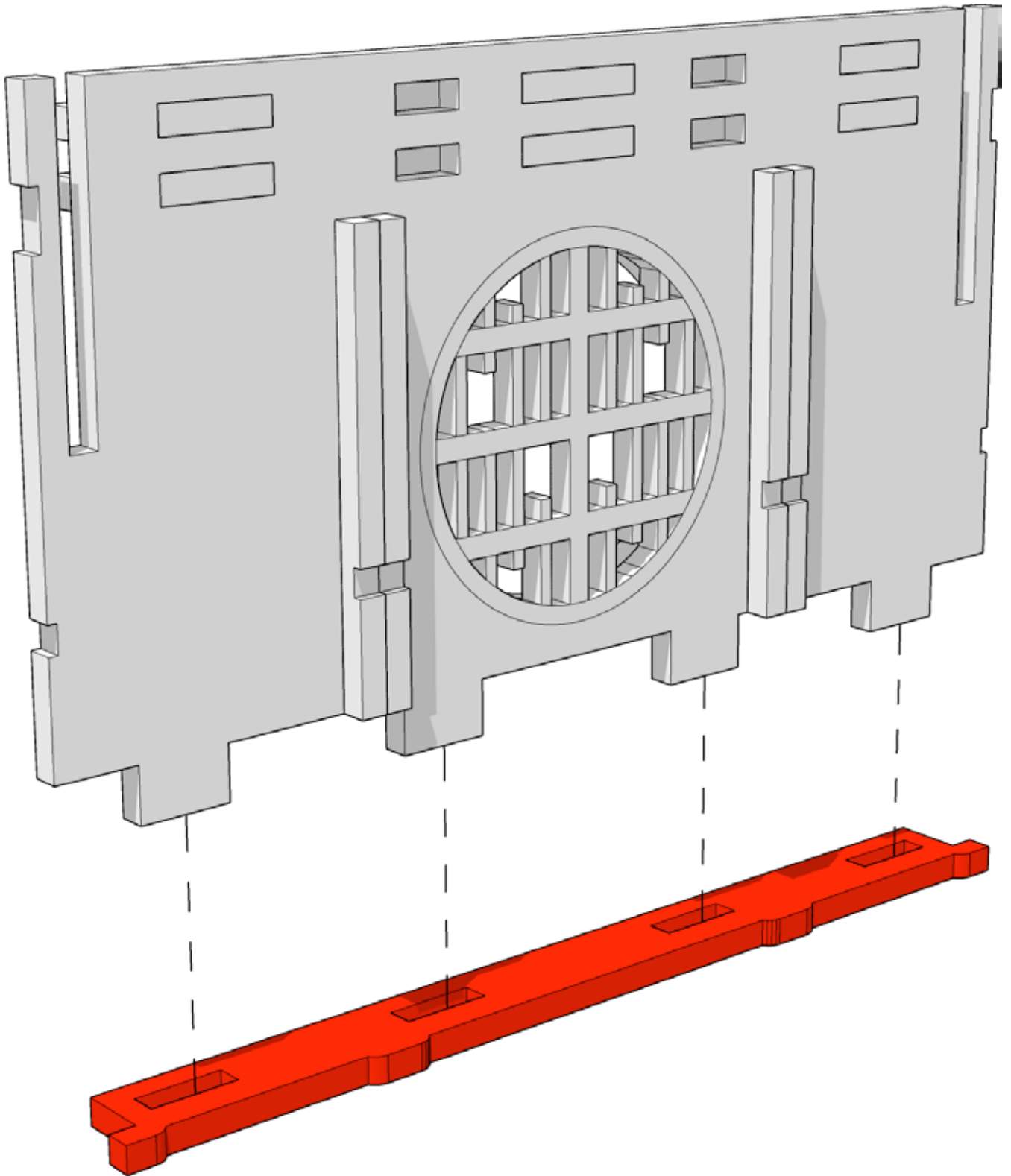



TABLETOP SCENICS

TTSCW-EES-115
Toshi:
Dojo

9

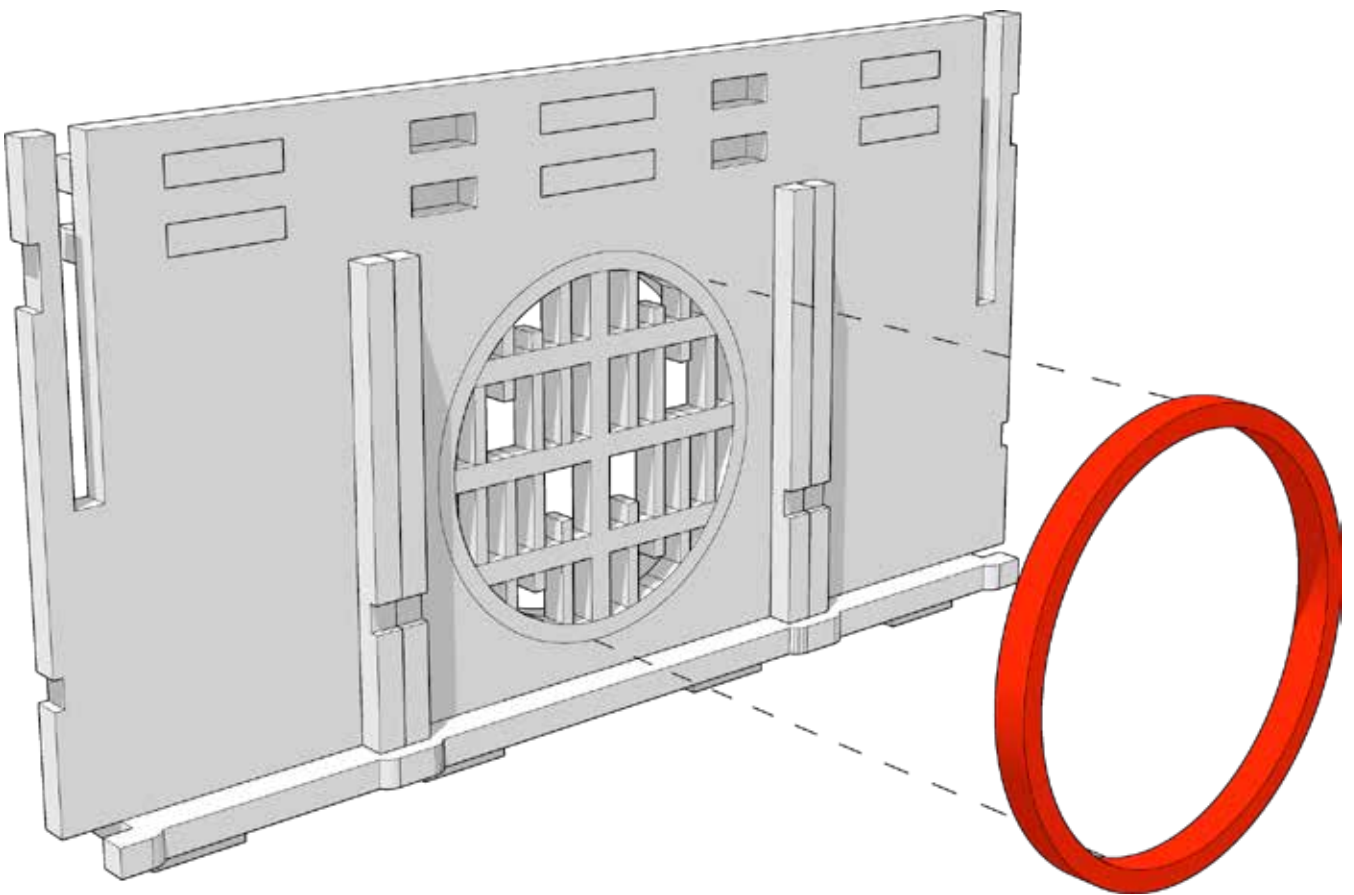



TABLETOP SCENICS

TTSCW-EES-115
Toshi:
Dojo

10

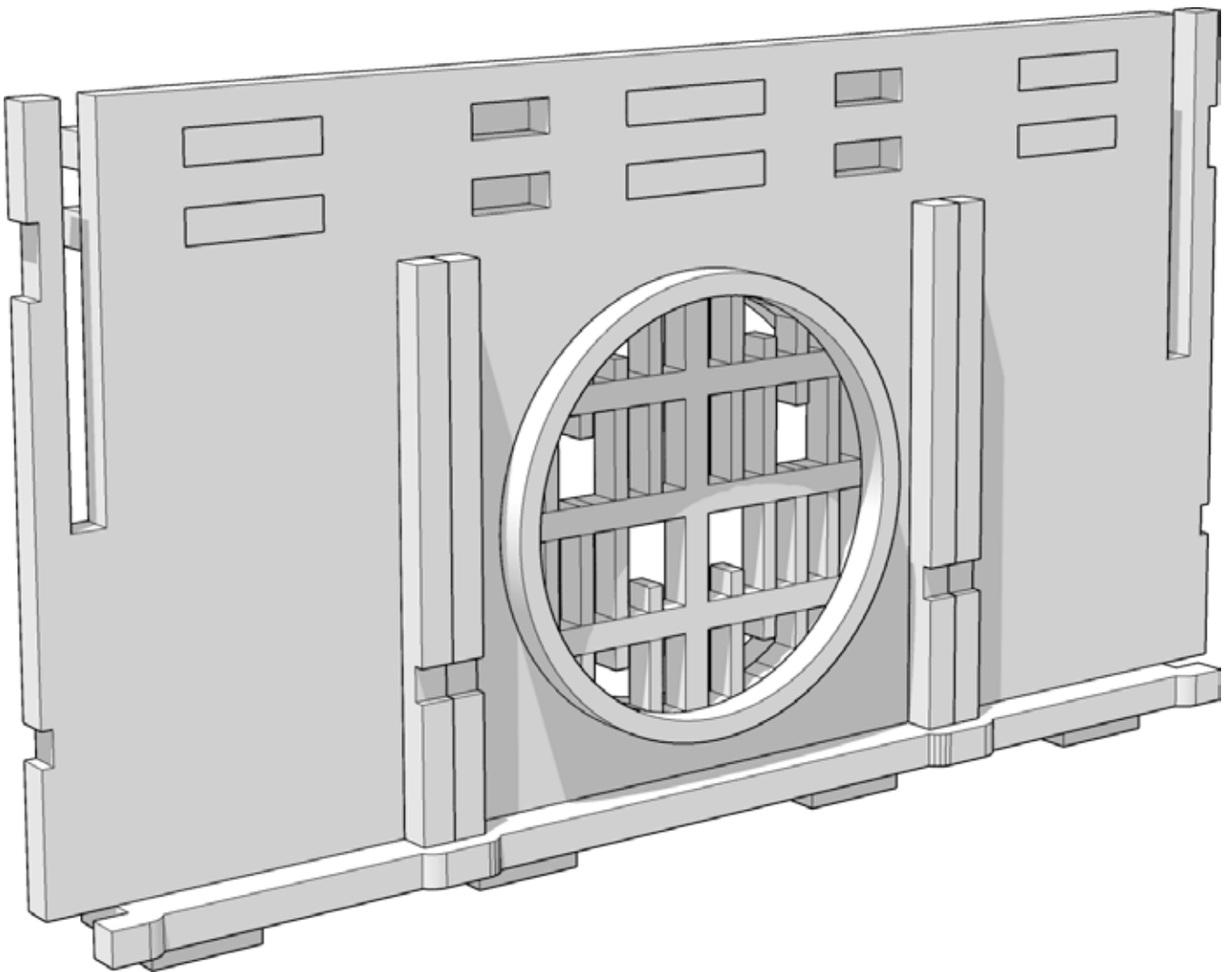

x2



TABLETOP SCENICS

TTSCW-EES-115
Toshi:
Dojo

11

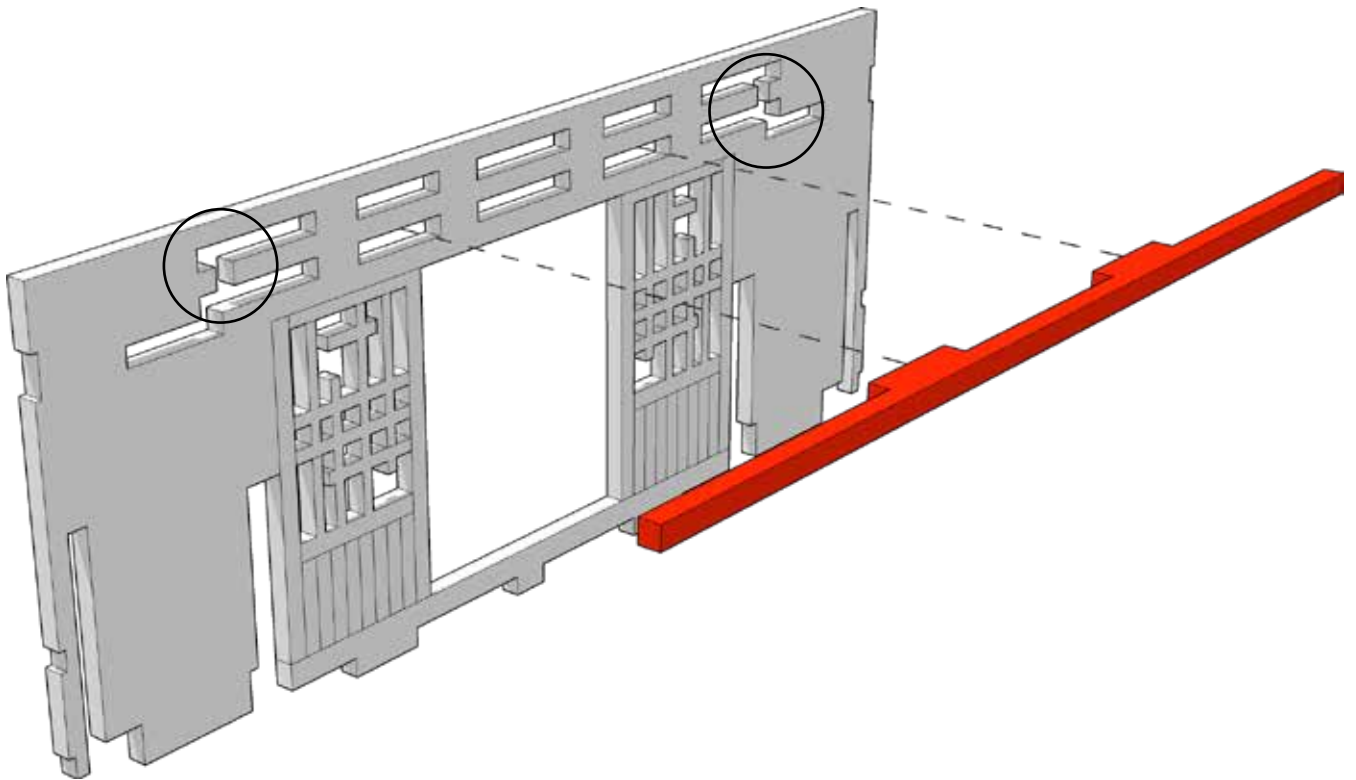

This wall piece is unique (as circled). Make note as its positioning is important in later steps.





TABLETOP SCENICS

TTSCW-EES-115
Toshi:
Dojo

12

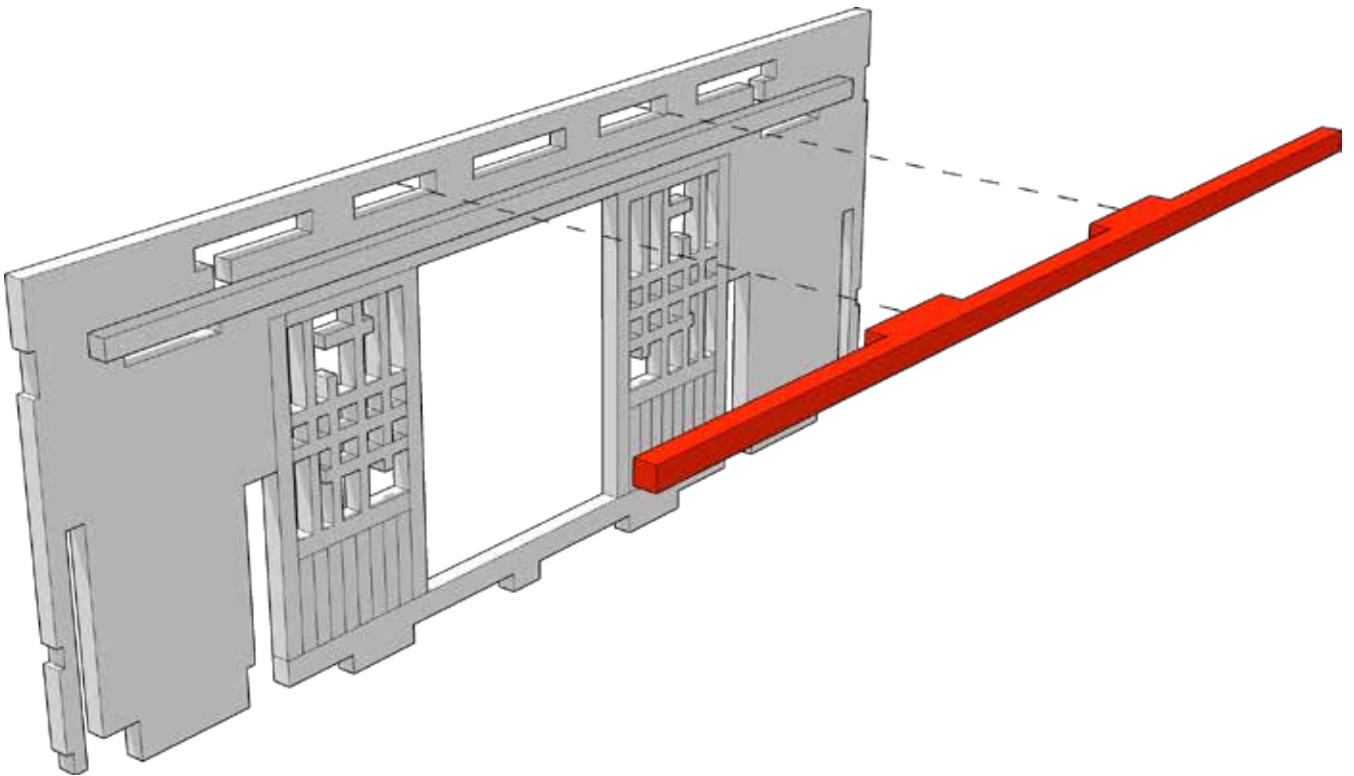



TABLETOP SCENICS

TTSCW-EES-115
Toshi:
Dojo

13

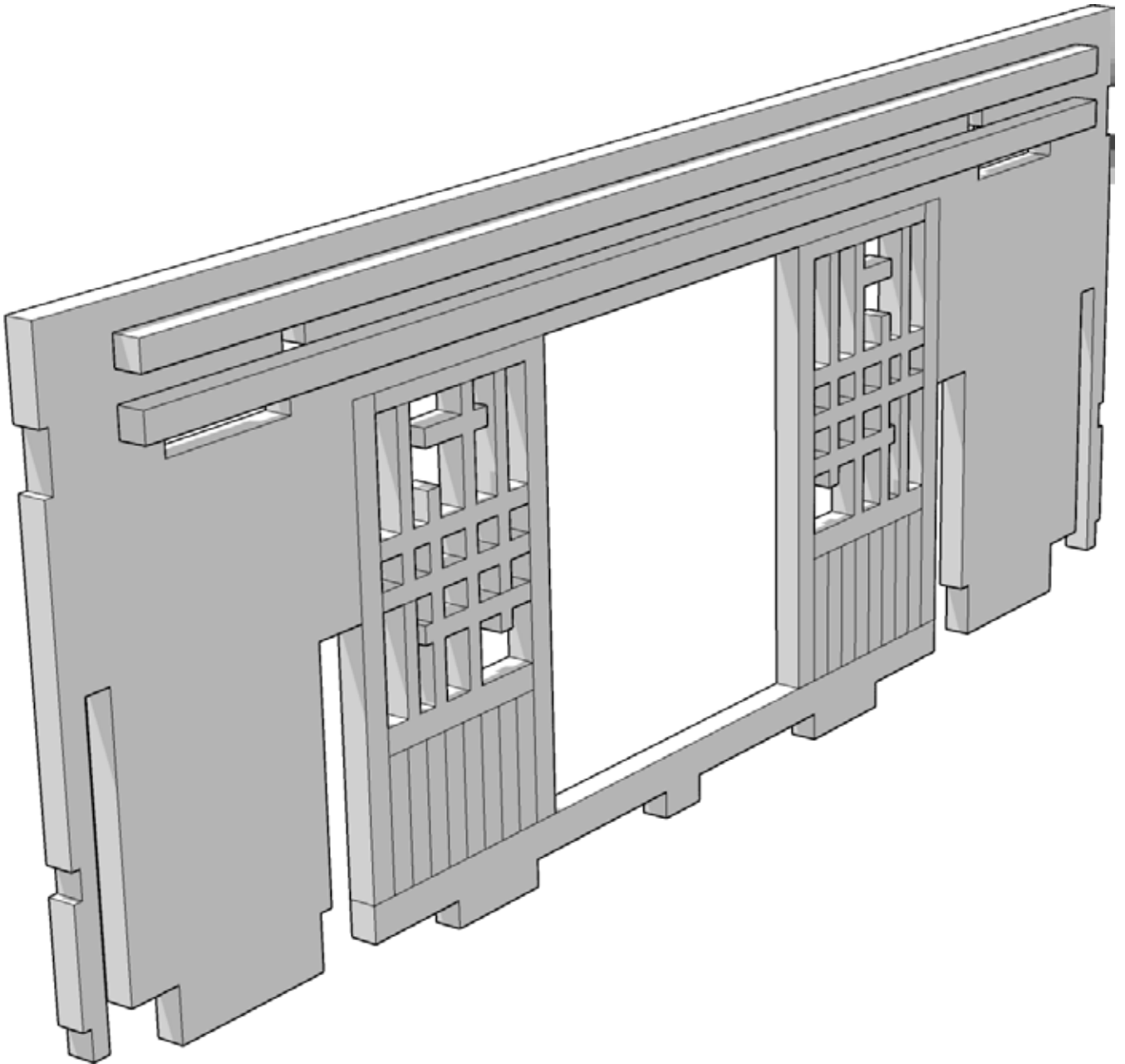



14

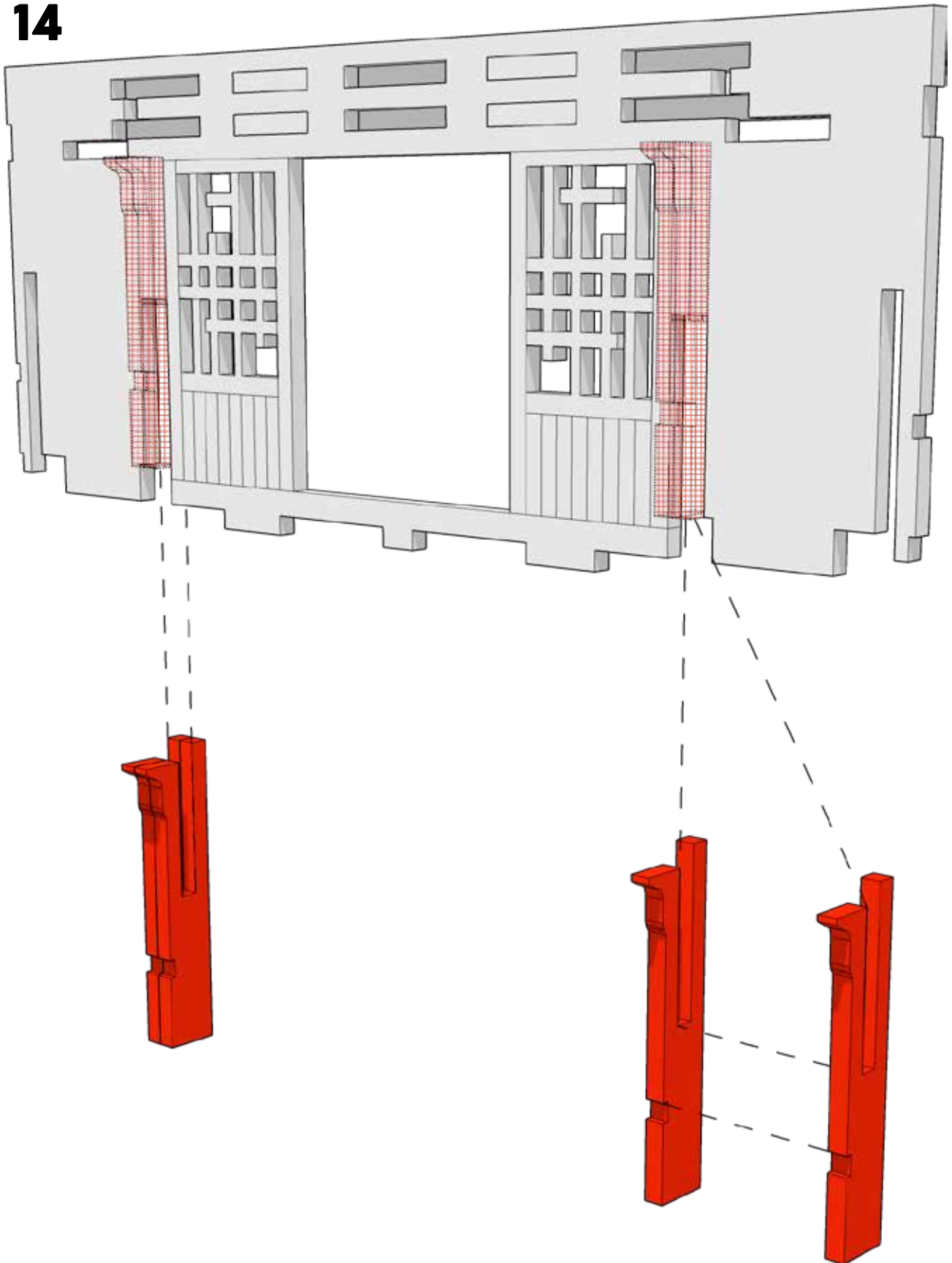

Parts join together and then slot
into place.



TABLETOP SCENICS

TTSCW-EES-115
Toshi:
Dojo

15

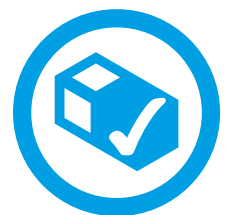
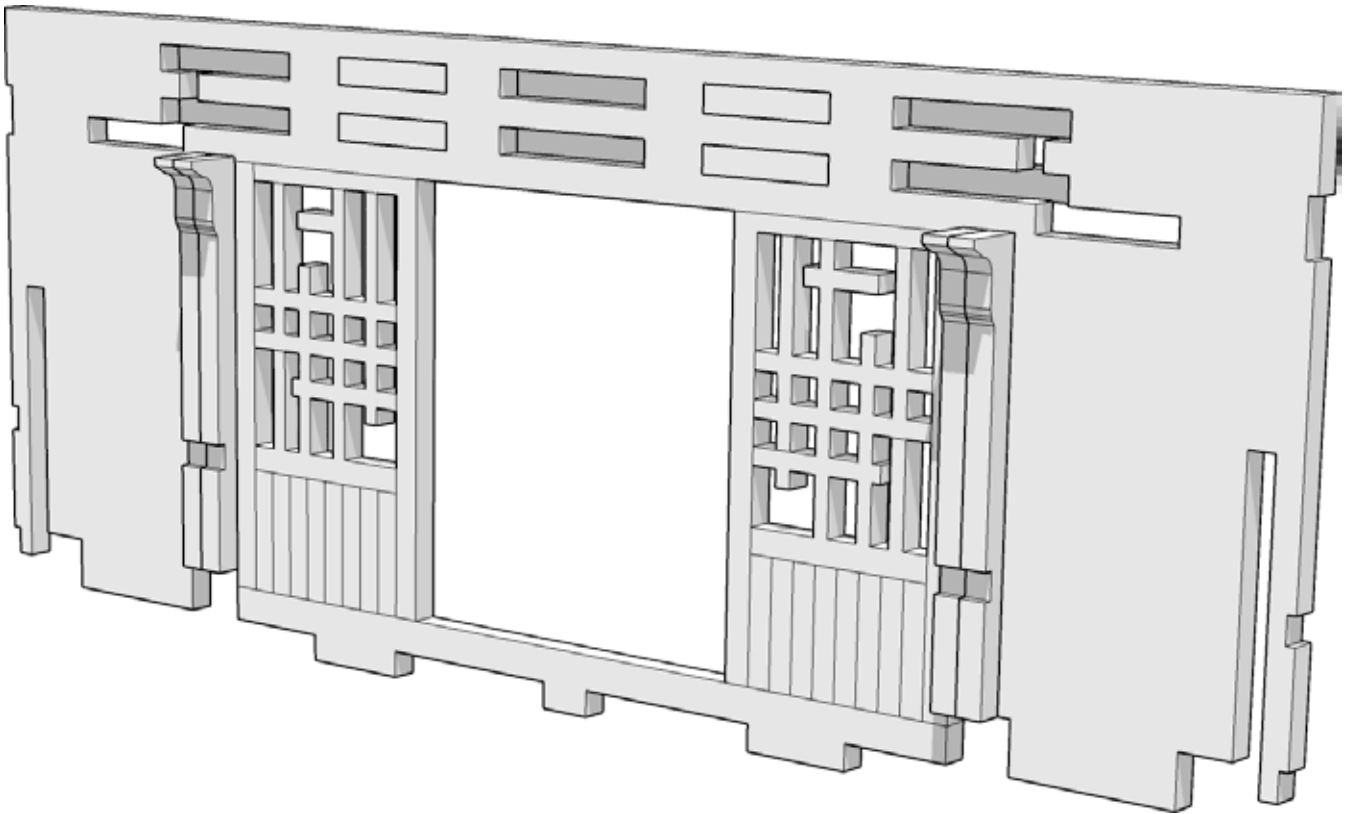



TABLETOP SCENICS

TTSCW-EES-115
Toshi:
Dojo

16

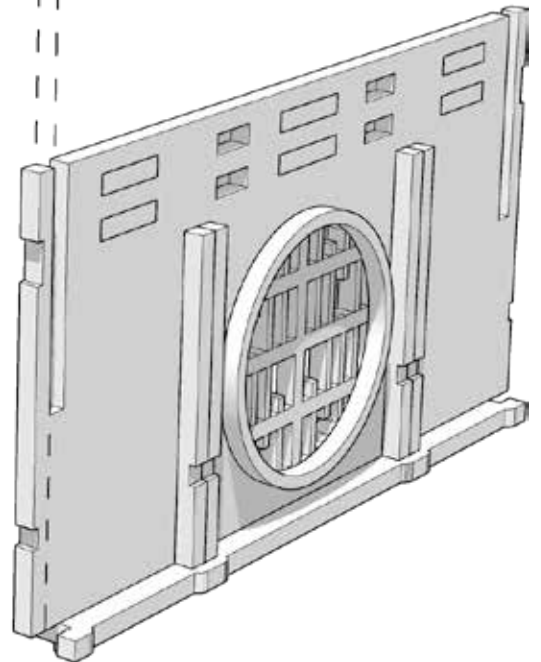
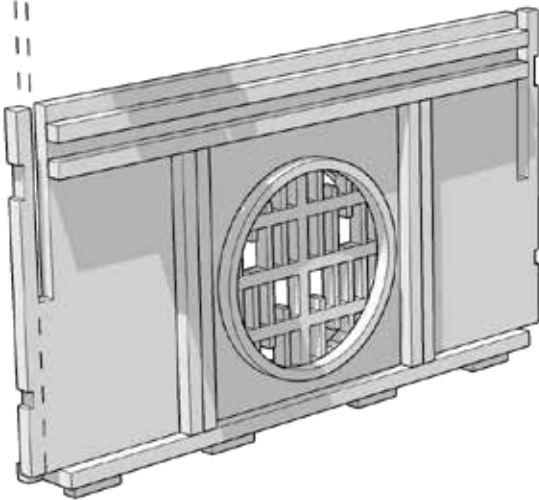
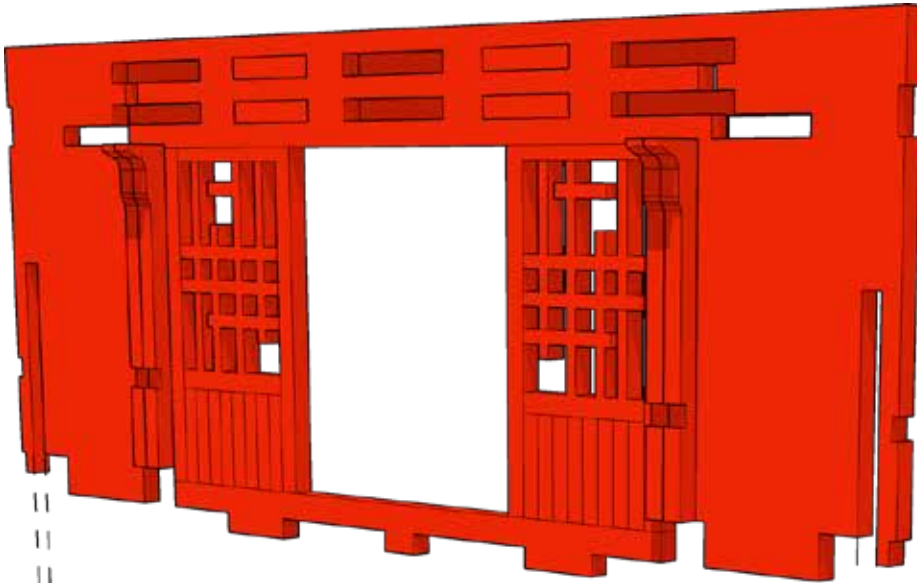



TABLETOP SCENICS

TTSCW-EES-115
Toshi:
Dojo

17

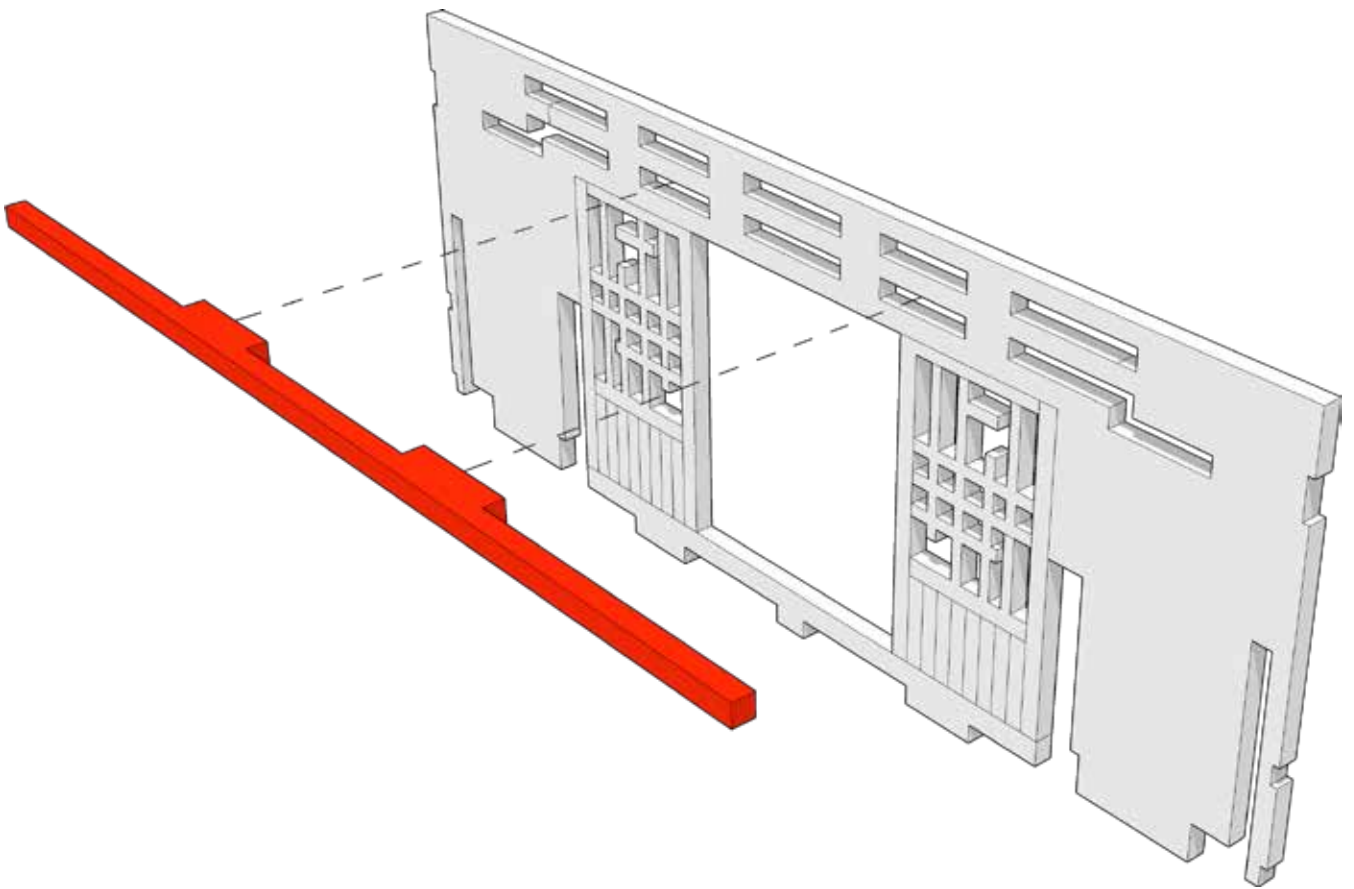



TABLETOP SCENICS

TTSCW-EES-115
Toshi:
Dojo

18

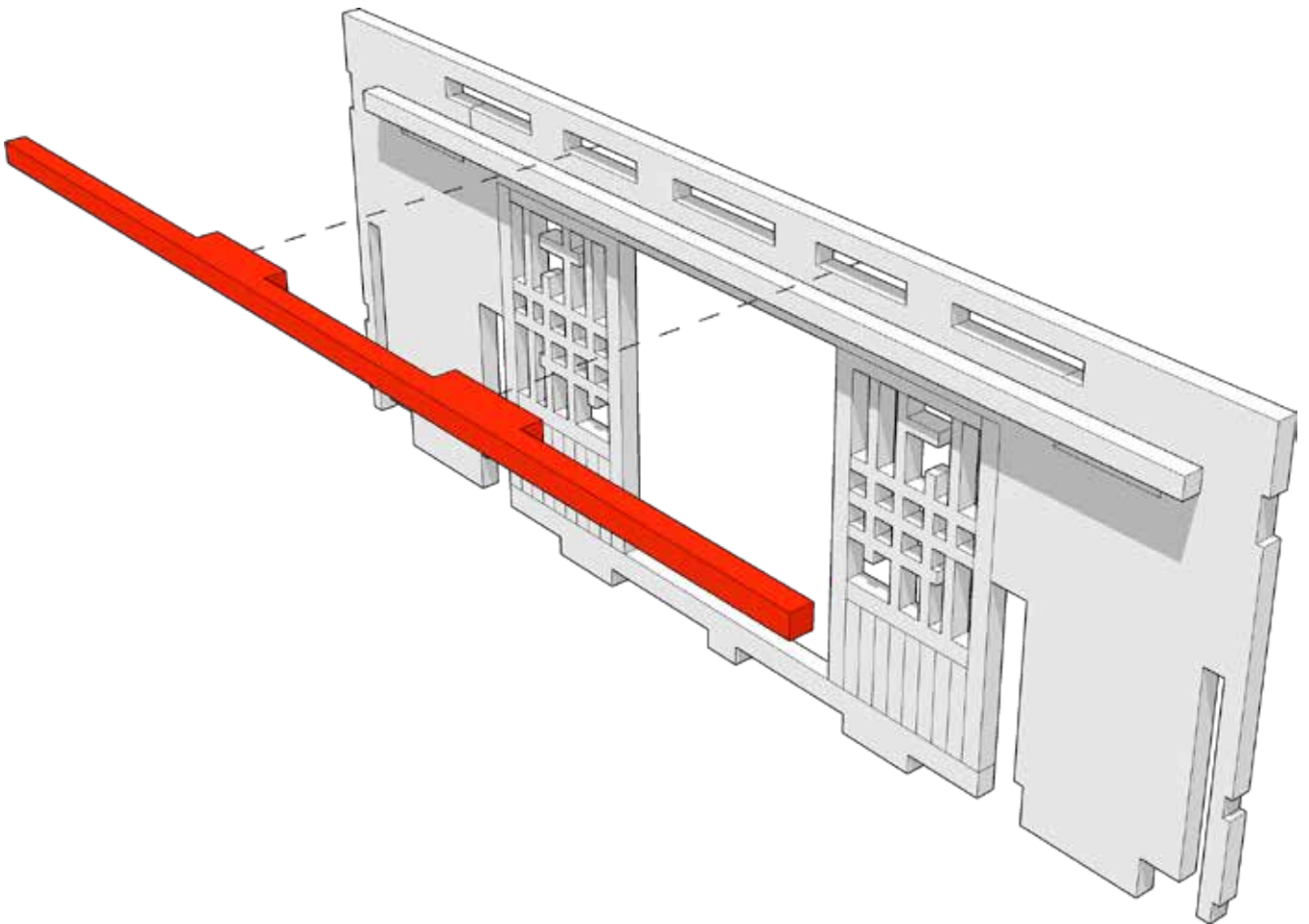



TABLETOP SCENICS

TTSCW-EES-115
Toshi:
Dojo

19

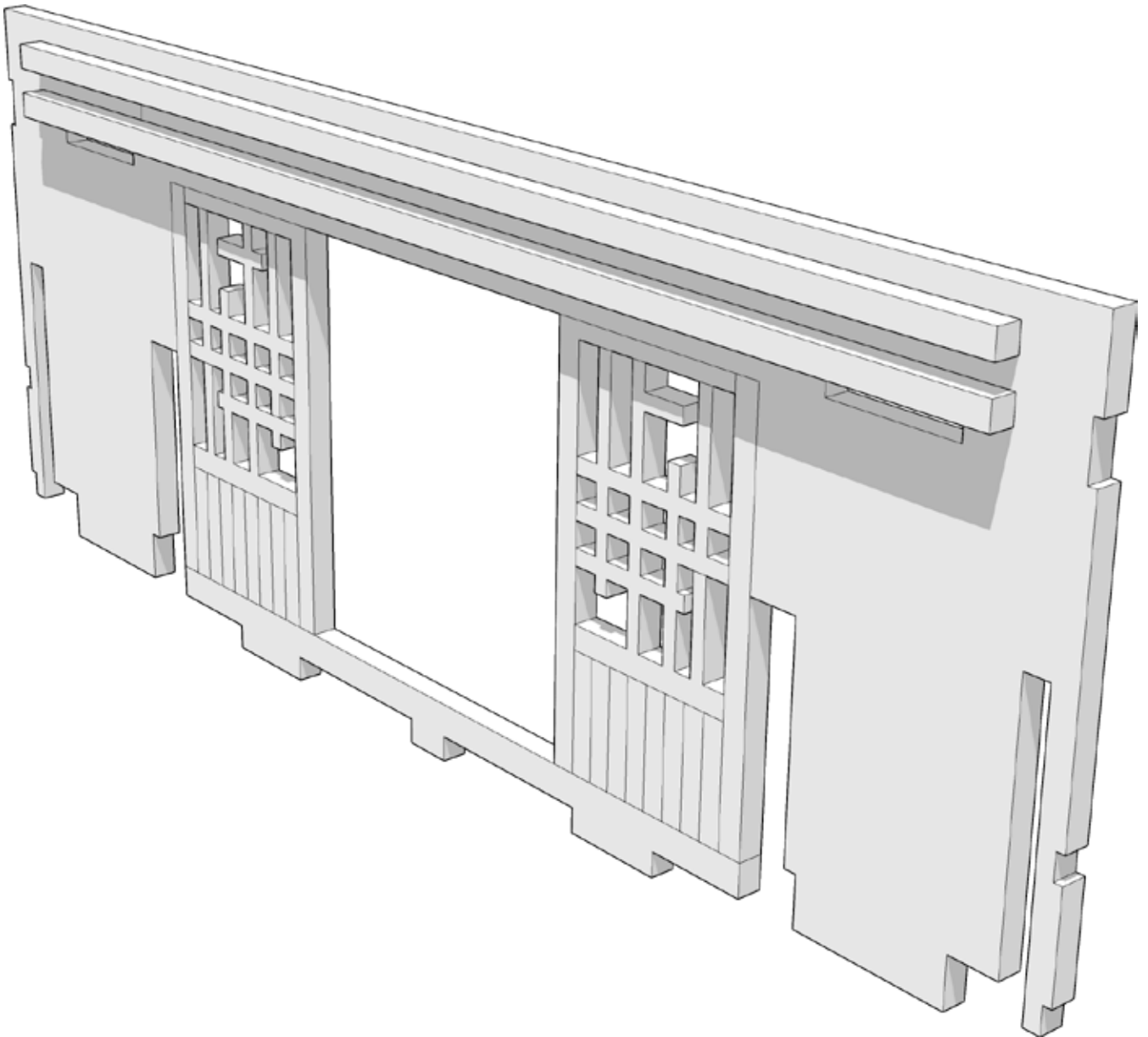



TABLETOP SCENICS

TTSCW-EES-115
Toshi:
Dojo

20

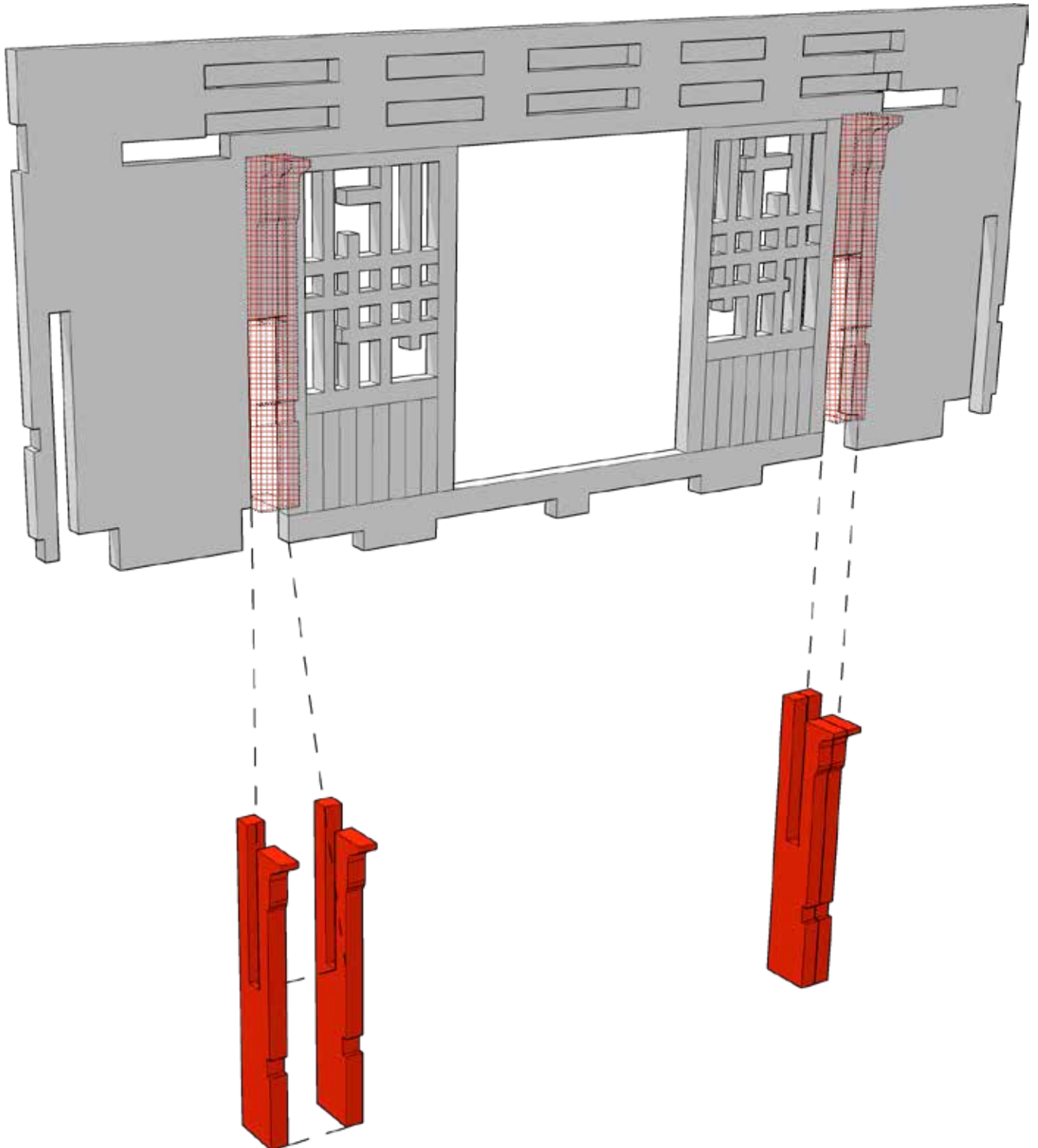



21

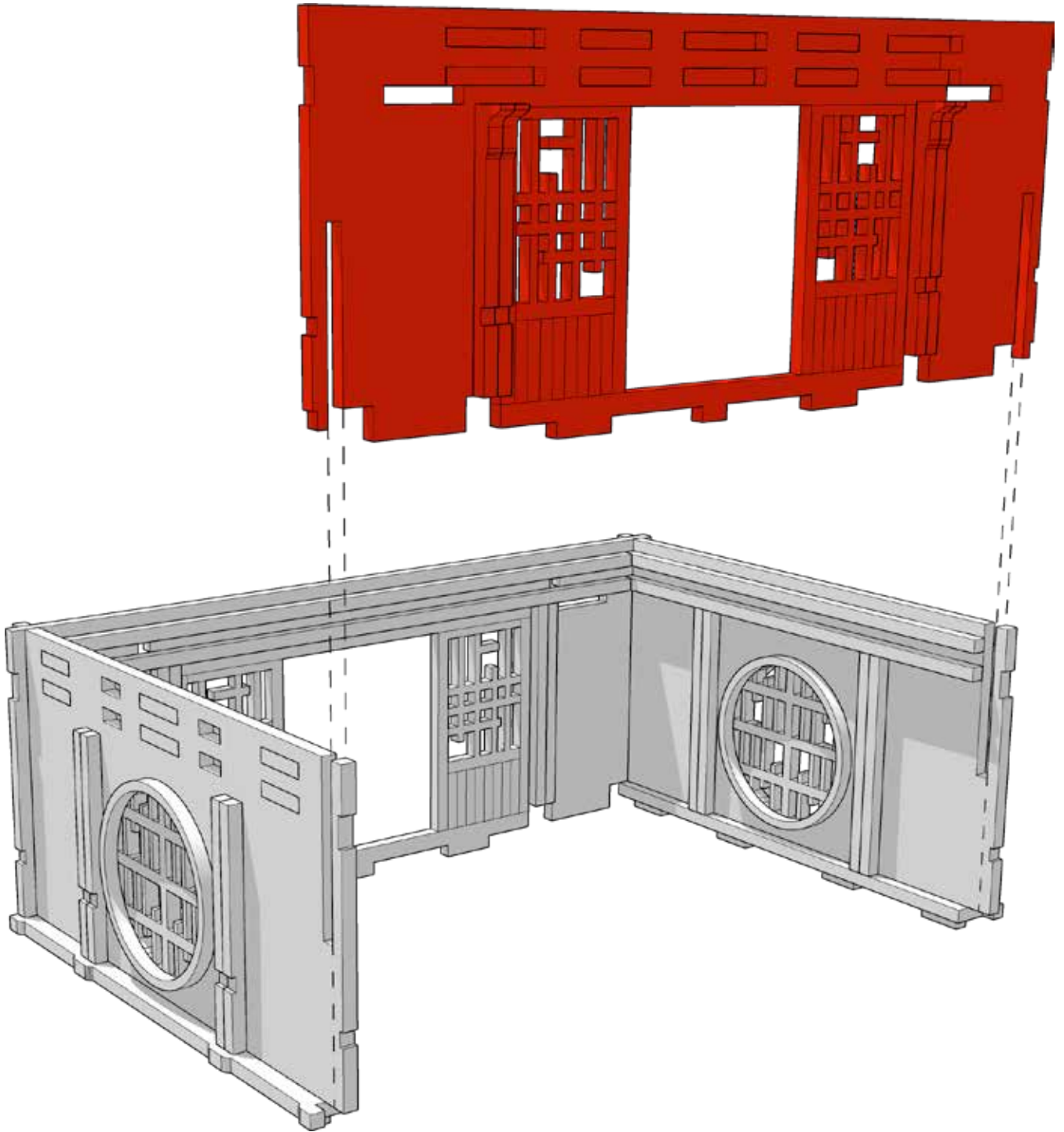



TABLETOP SCENICS

TTSCW-EES-115
Toshi:
Dojo

22

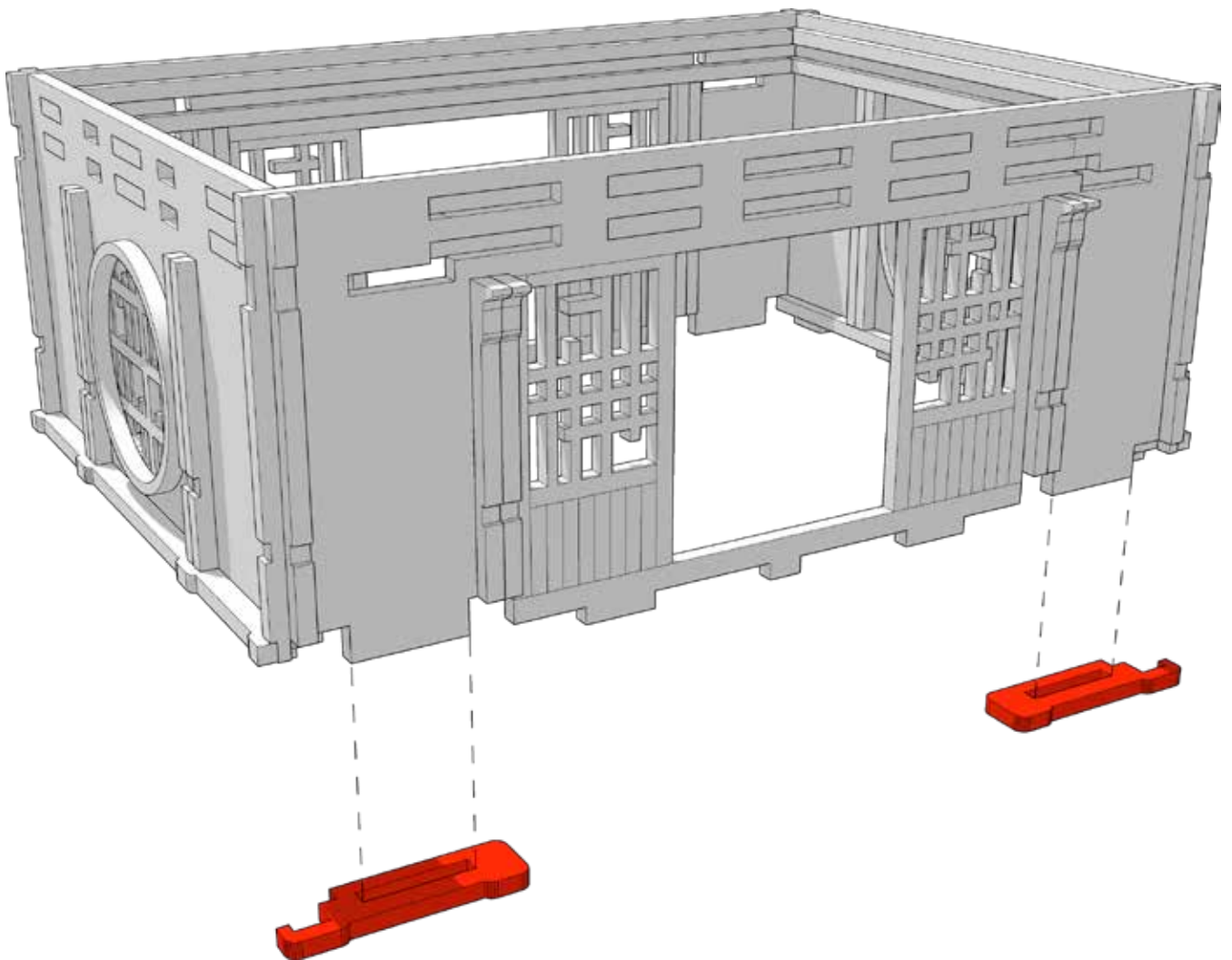



TABLETOP SCENICS

TTSCW-EES-115
Toshi:
Dojo

23

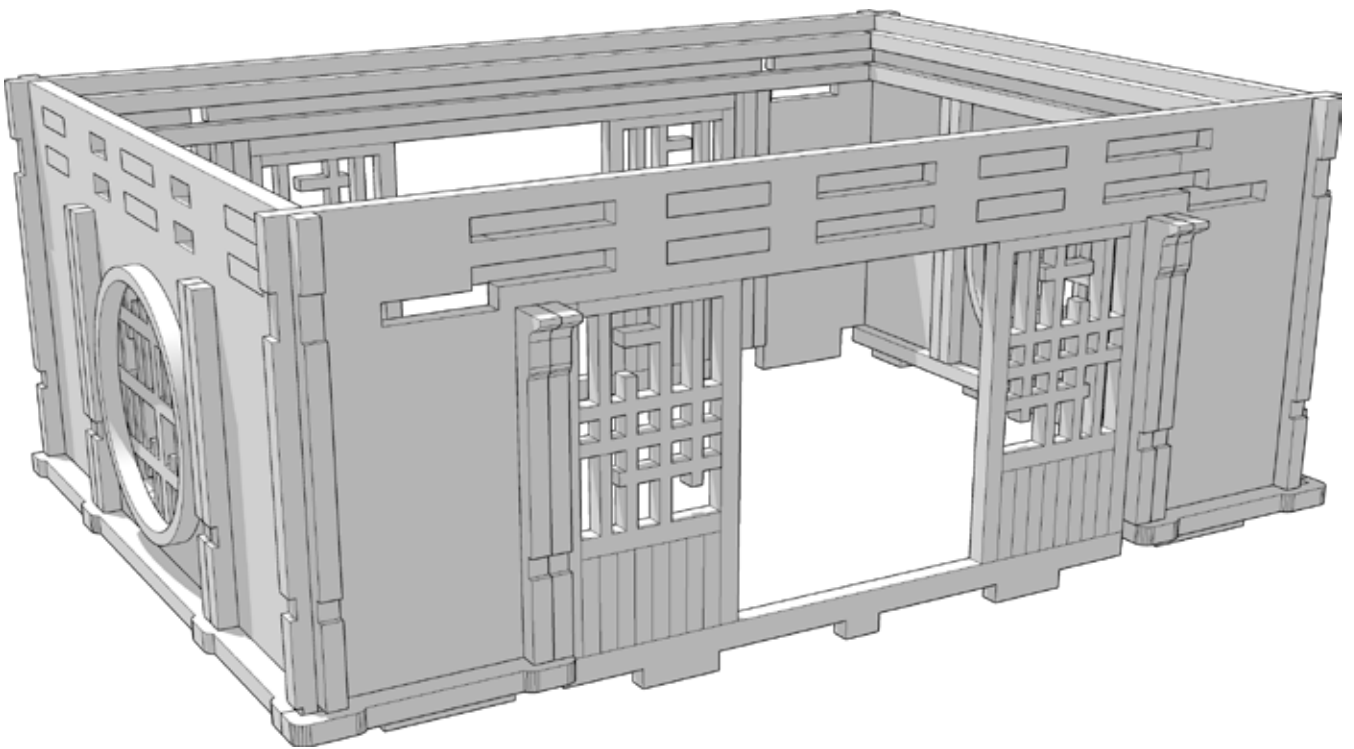



TABLETOP SCENICS

TTSCW-EES-115
Toshi:
Dojo

24

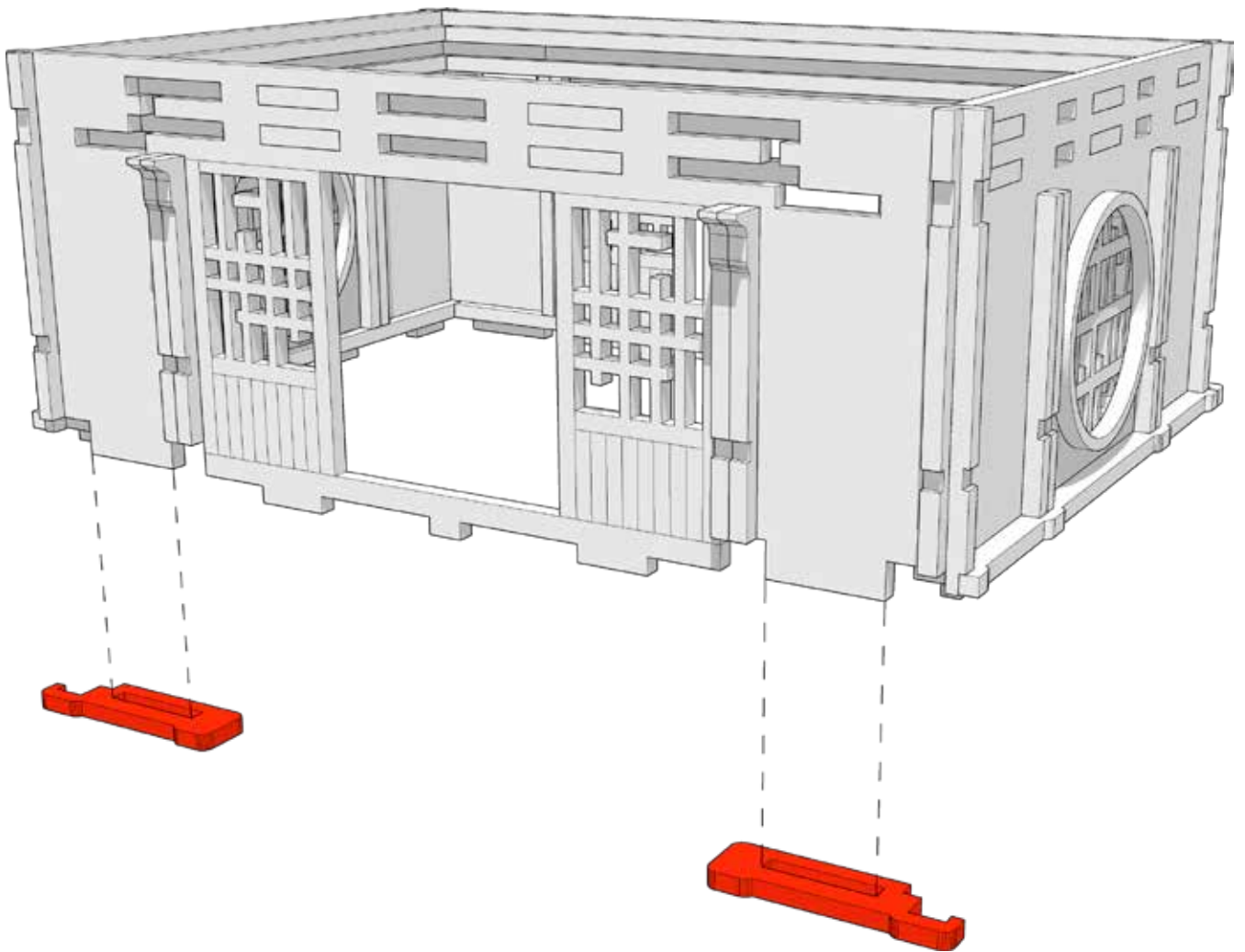



TABLETOP SCENICS

TTSCW-EES-115
Toshi:
Dojo

25

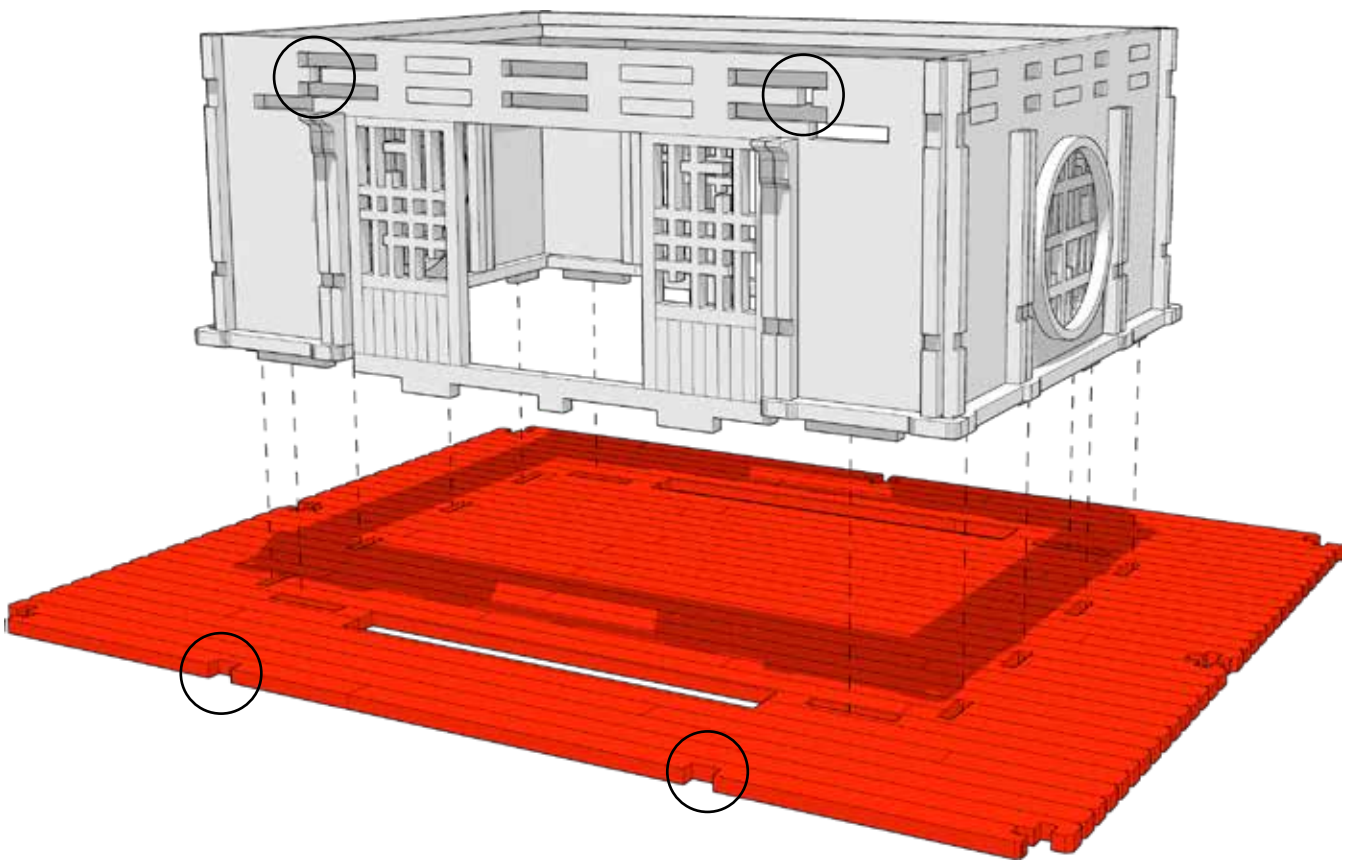

Wall (circled) must match the position of the floor
(circled)



TABLETOP SCENICS

TTSCW-EES-115
Toshi:
Dojo

26

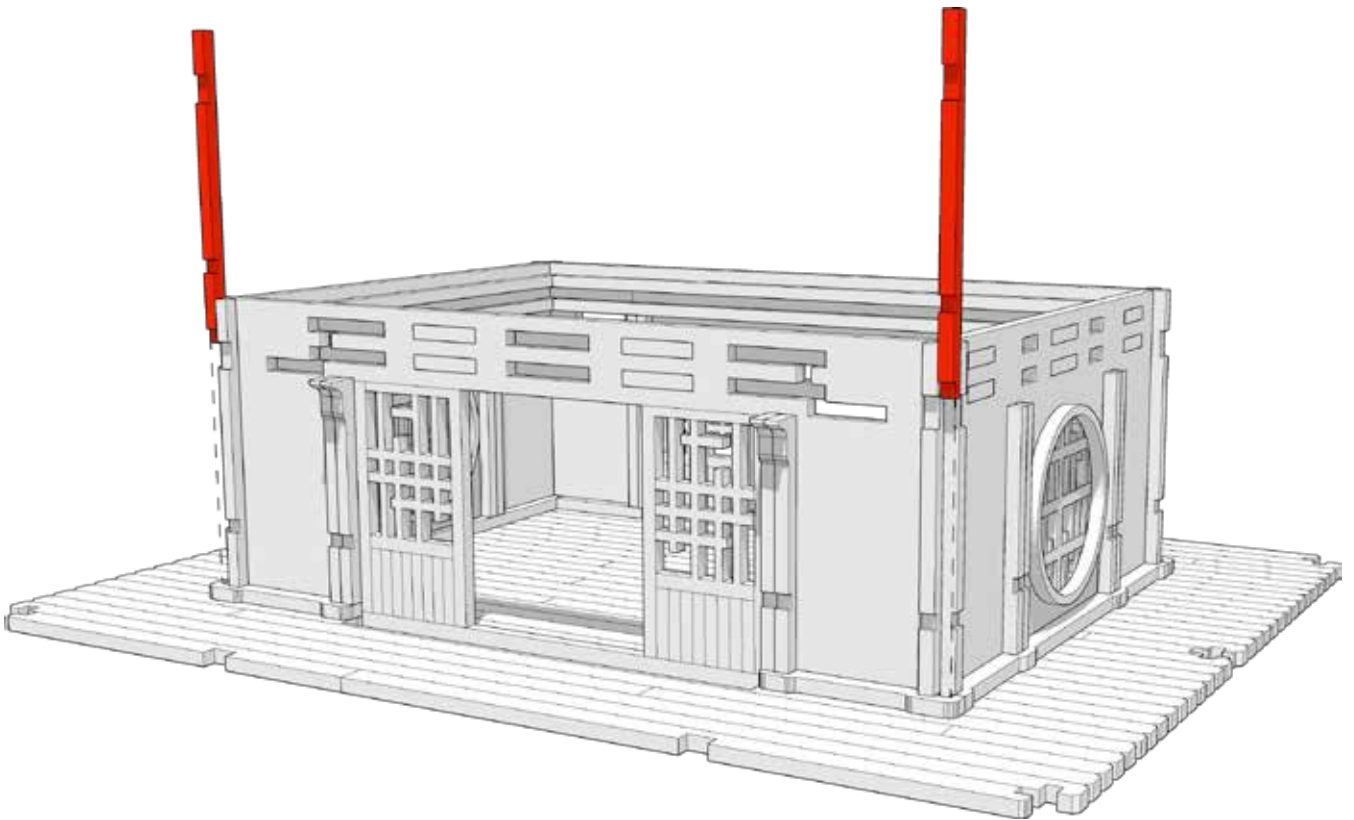



TABLETOP SCENICS

TTSCW-EES-115
Toshi:
Dojo

27

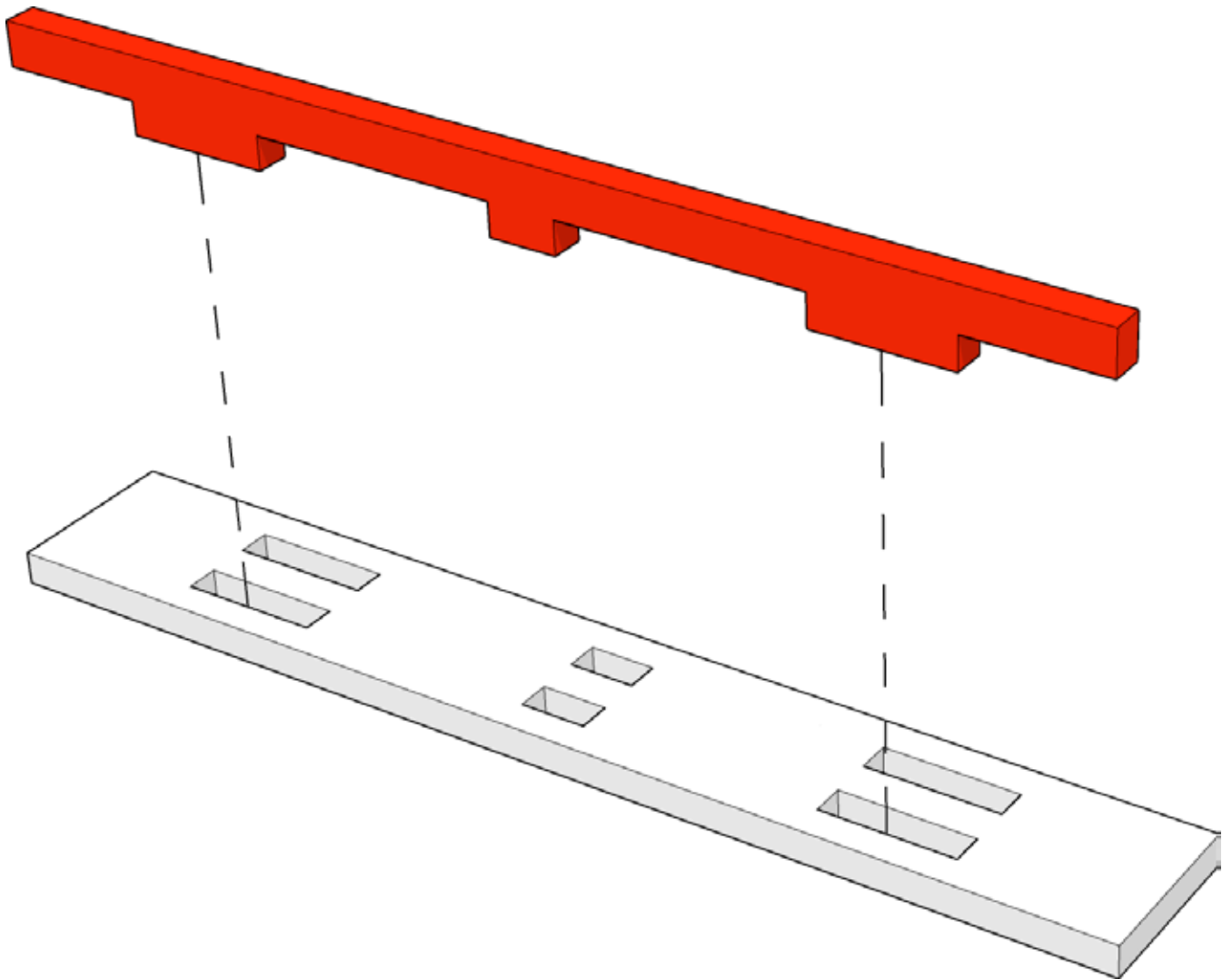



TABLETOP SCENICS

TTSCW-EES-115
Toshi:
Dojo

28

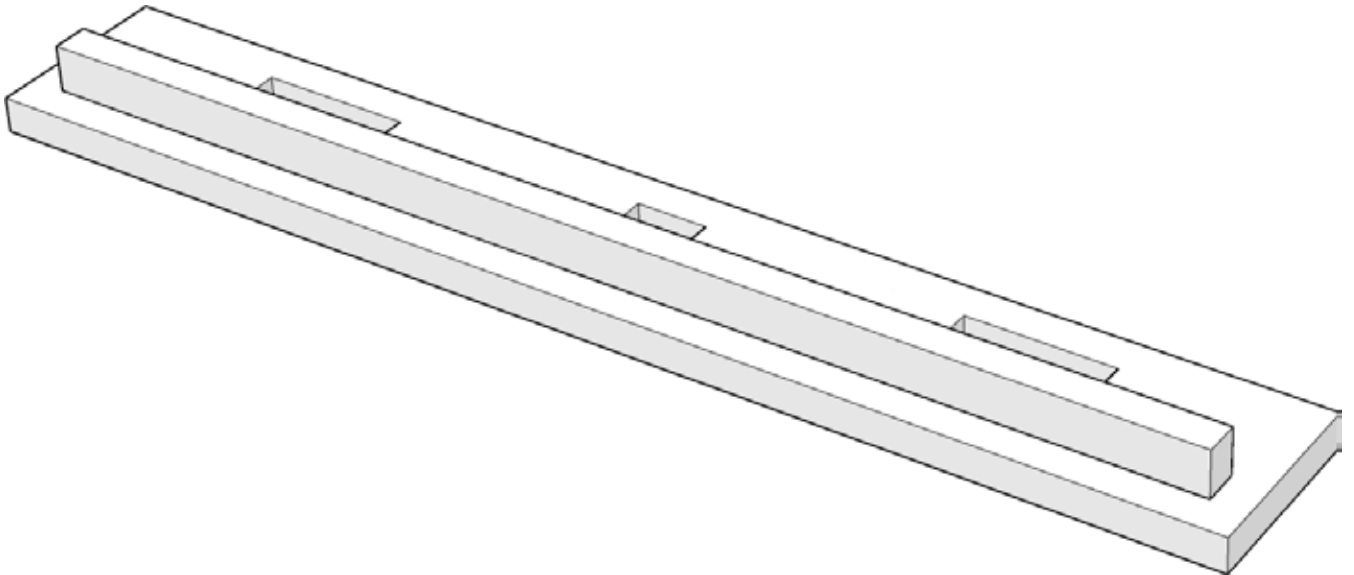

x2



TABLETOP SCENICS

TTSCW-EES-115

Toshi:

Dojo

29

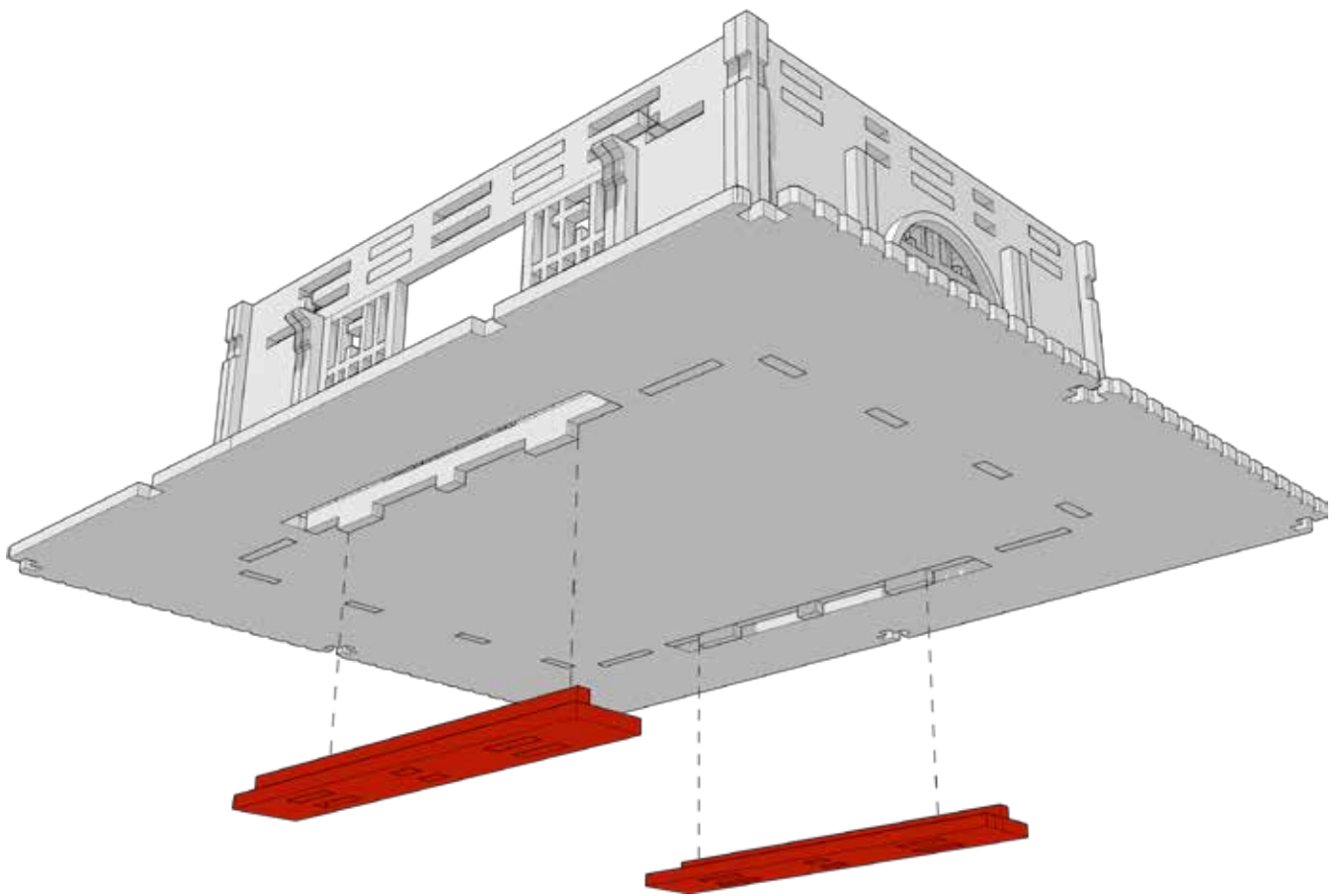

Highlighted parts slot up into the floor and connect
to the wall tabs





TABLETOP SCENICS

TTSCW-EES-115
Toshi:
Dojo

30

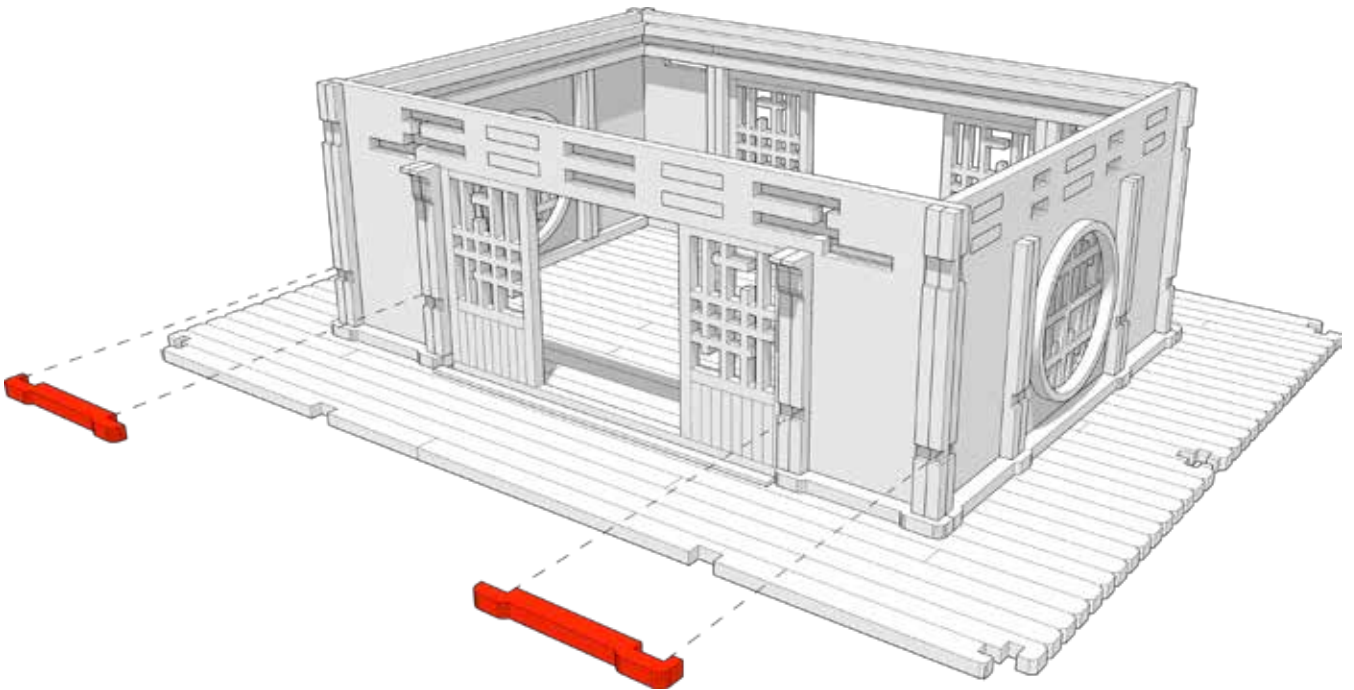



TABLETOP SCENICS

TTSCW-EES-115
Toshi:
Dojo

31

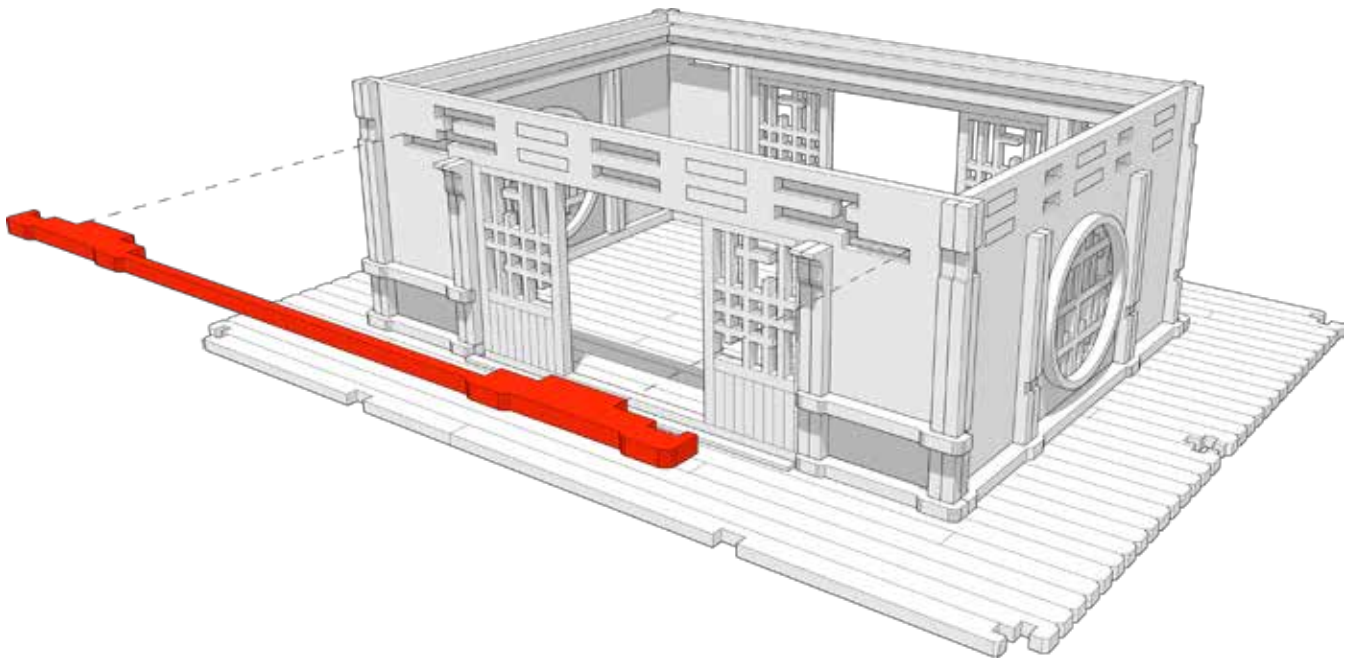



TABLETOP SCENICS

TTSCW-EES-115
Toshi:
Dojo

32

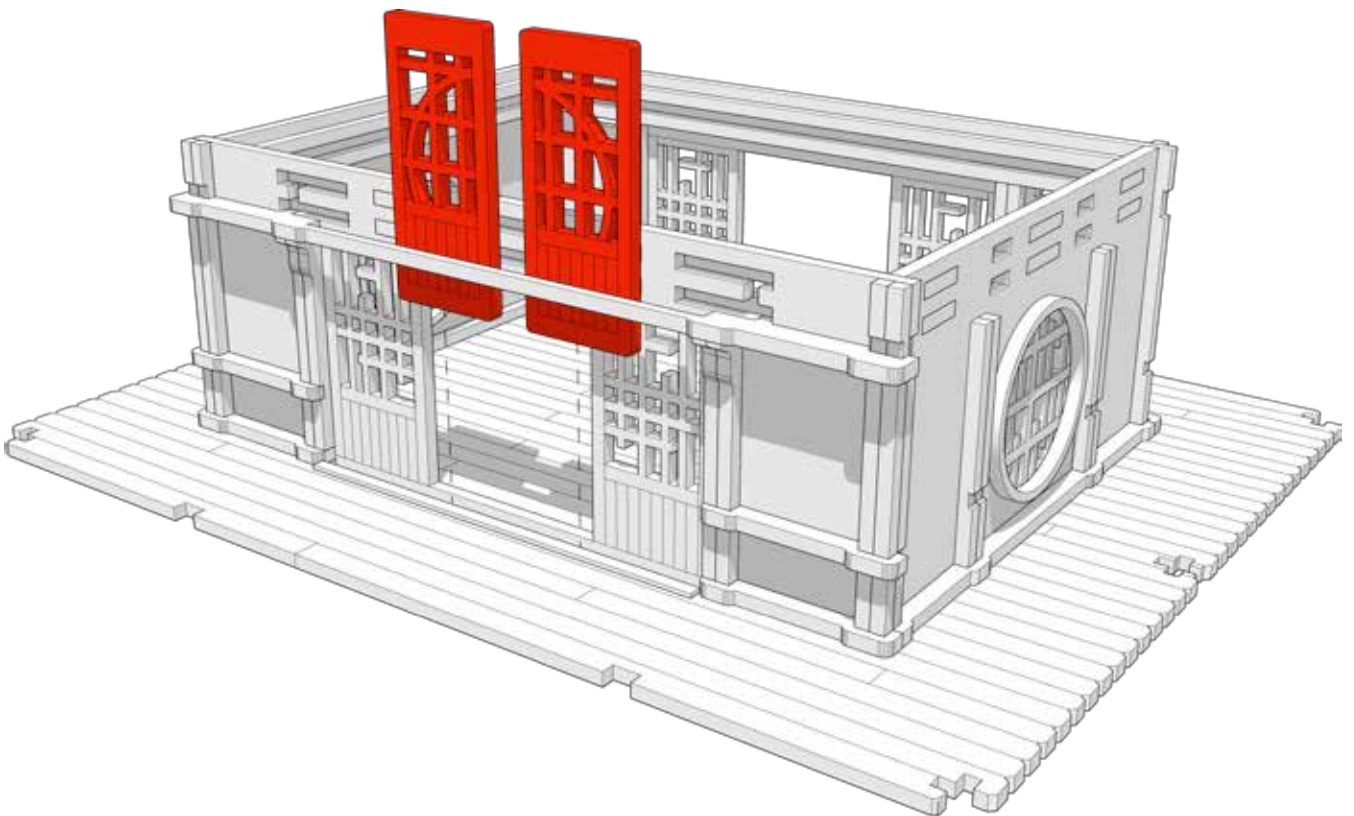

Doors should move freely in the floor slot and behind the upper rail place in the last step



 **TTCOMBAT**



TABLETOP SCENICS

TTSCW-EES-115
Toshi:
Dojo

33

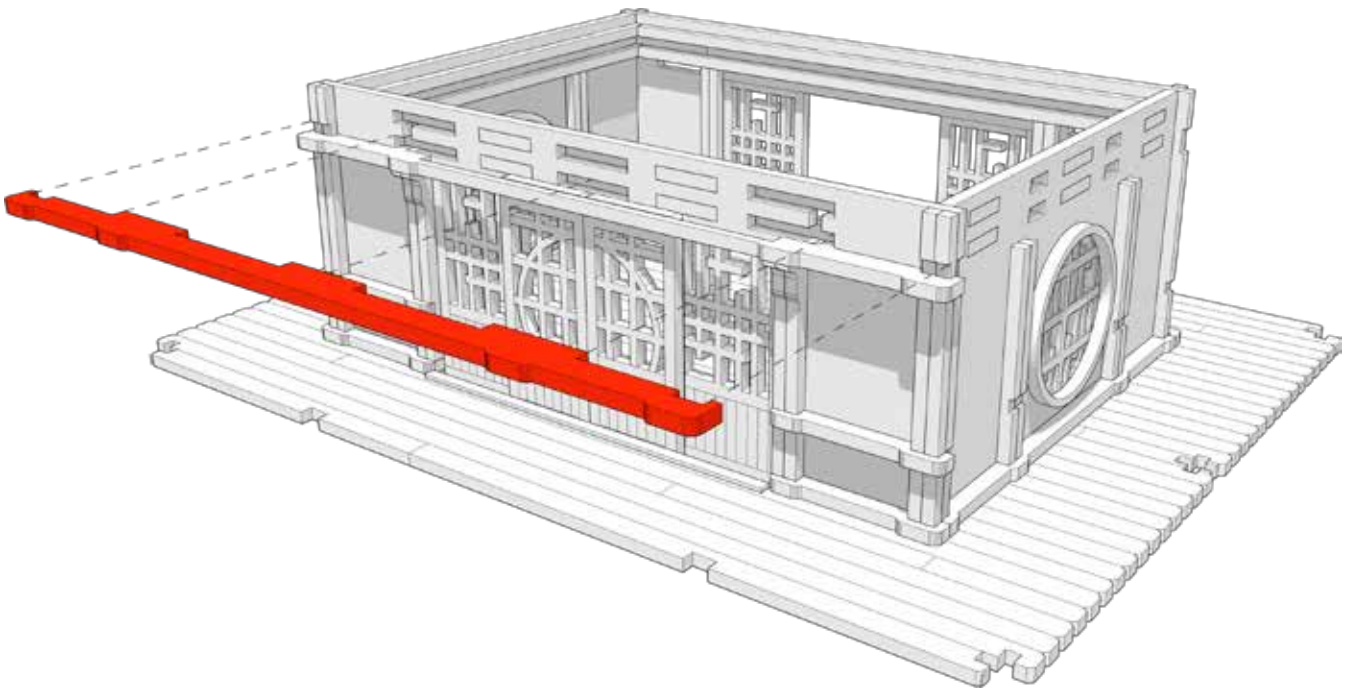

Do NOT get glue where the sliding doors would touch



 **TTCOMBAT**



TABLETOP SCENICS

TTSCW-EES-115
Toshi:
Dojo

34

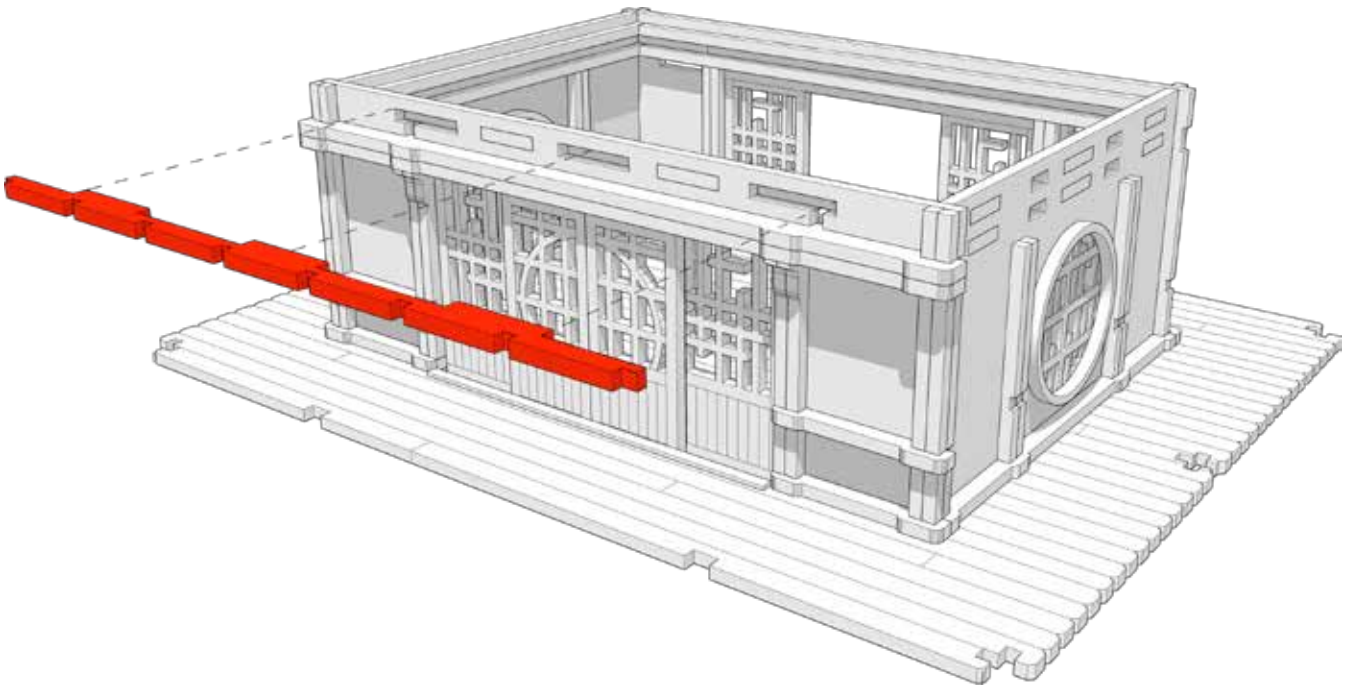



TABLETOP SCENICS

TTSCW-EES-115
Toshi:
Dojo

35

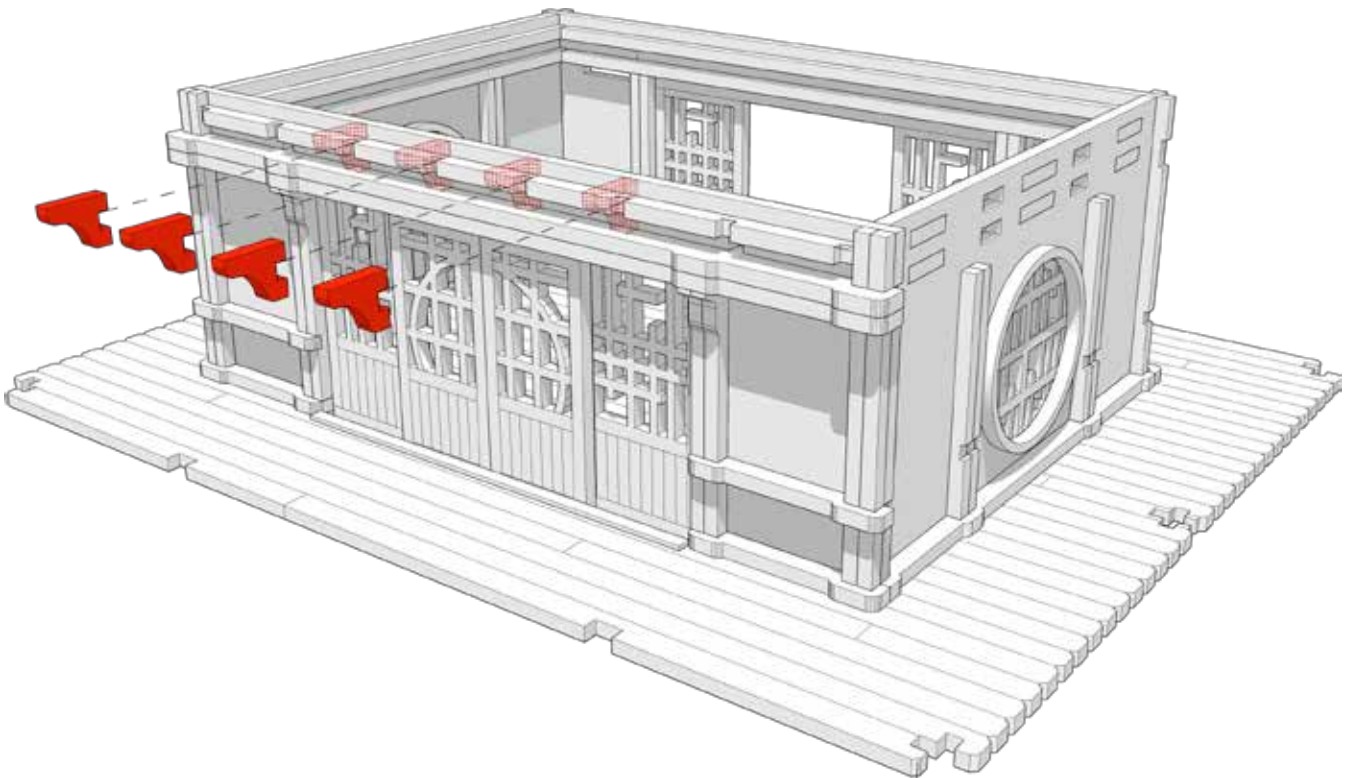



TABLETOP SCENICS

TTSCW-EES-115
Toshi:
Dojo

36

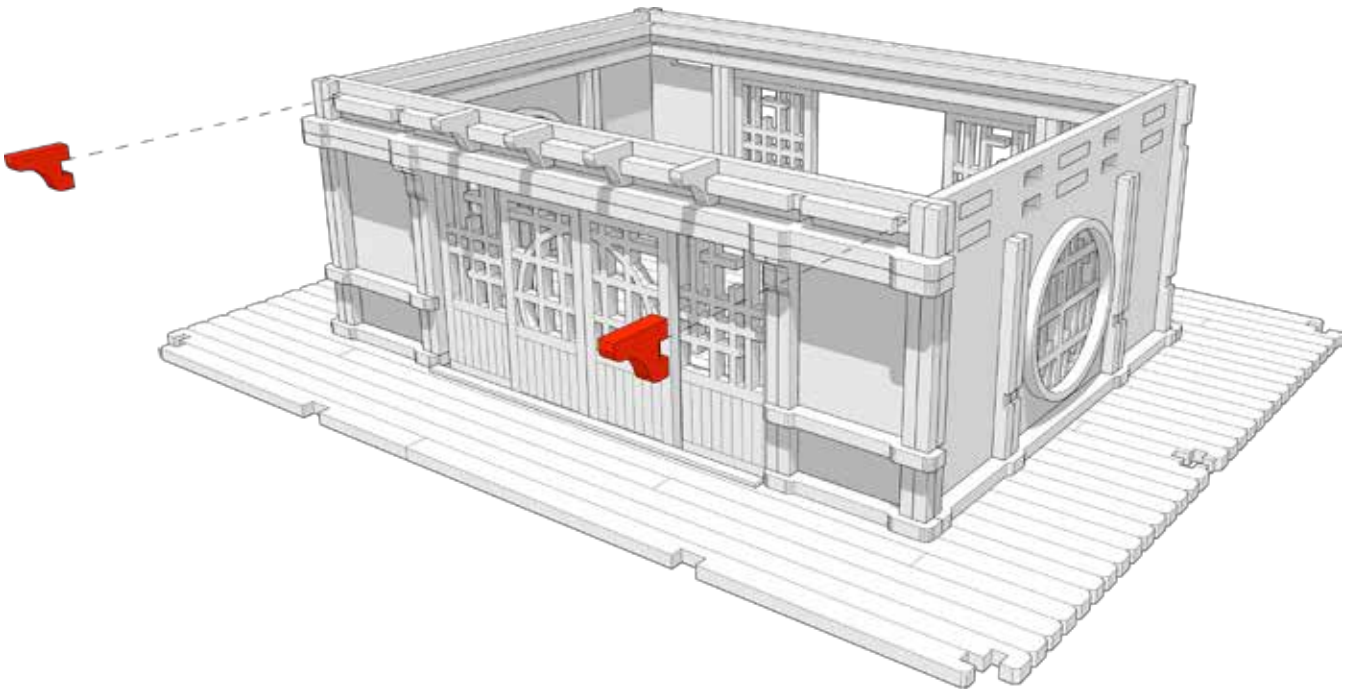



TABLETOP SCENICS

TTSCW-EES-115
Toshi:
Dojo

37

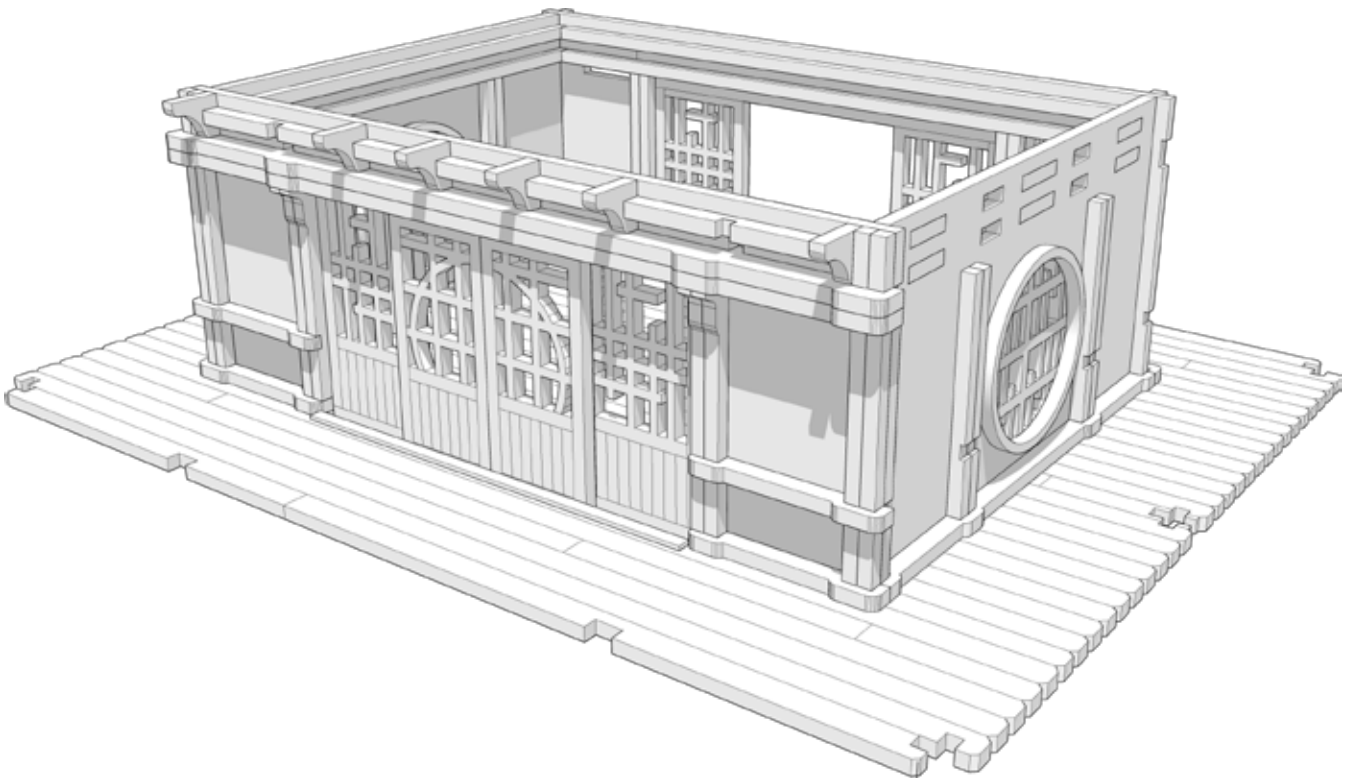



TABLETOP SCENICS

TTSCW-EES-115
Toshi:
Dojo

38

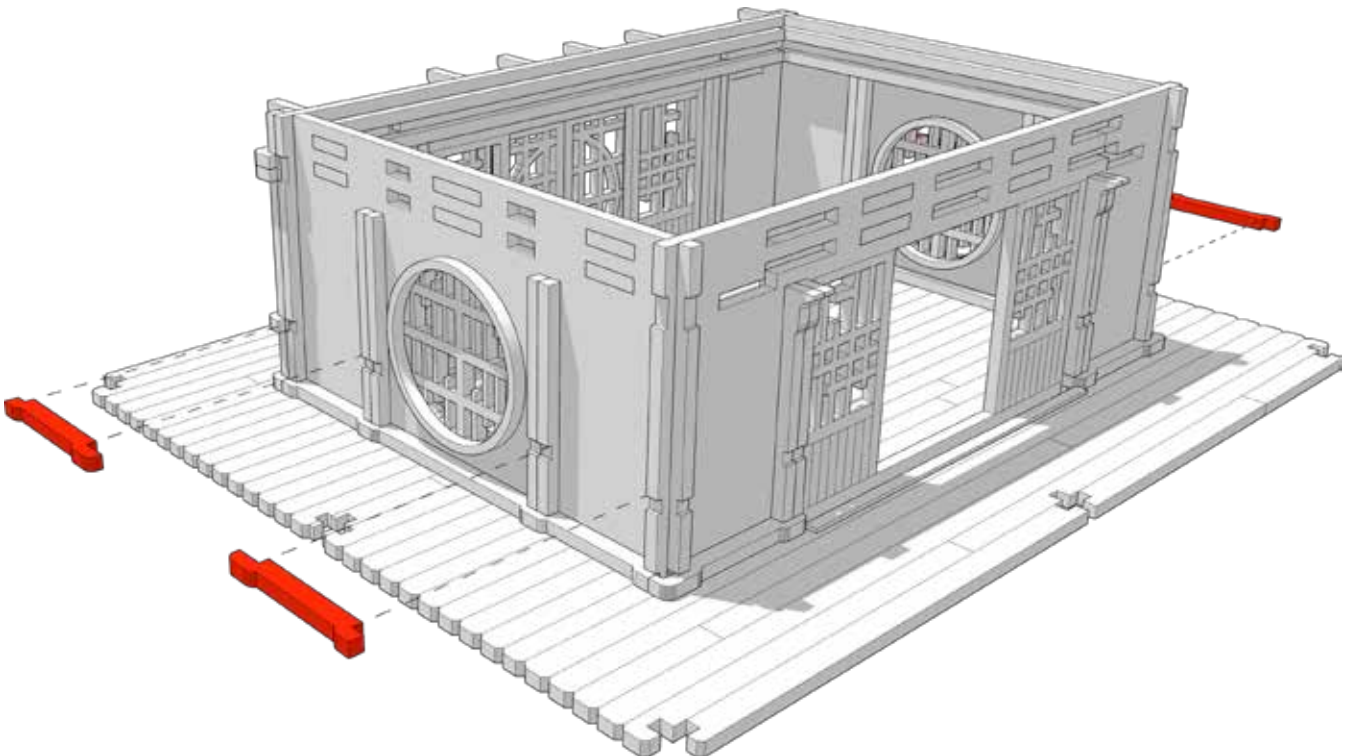

Repeat steps on both sides



TABLETOP SCENICS

TTSCW-EES-115
Toshi:
Dojo

39

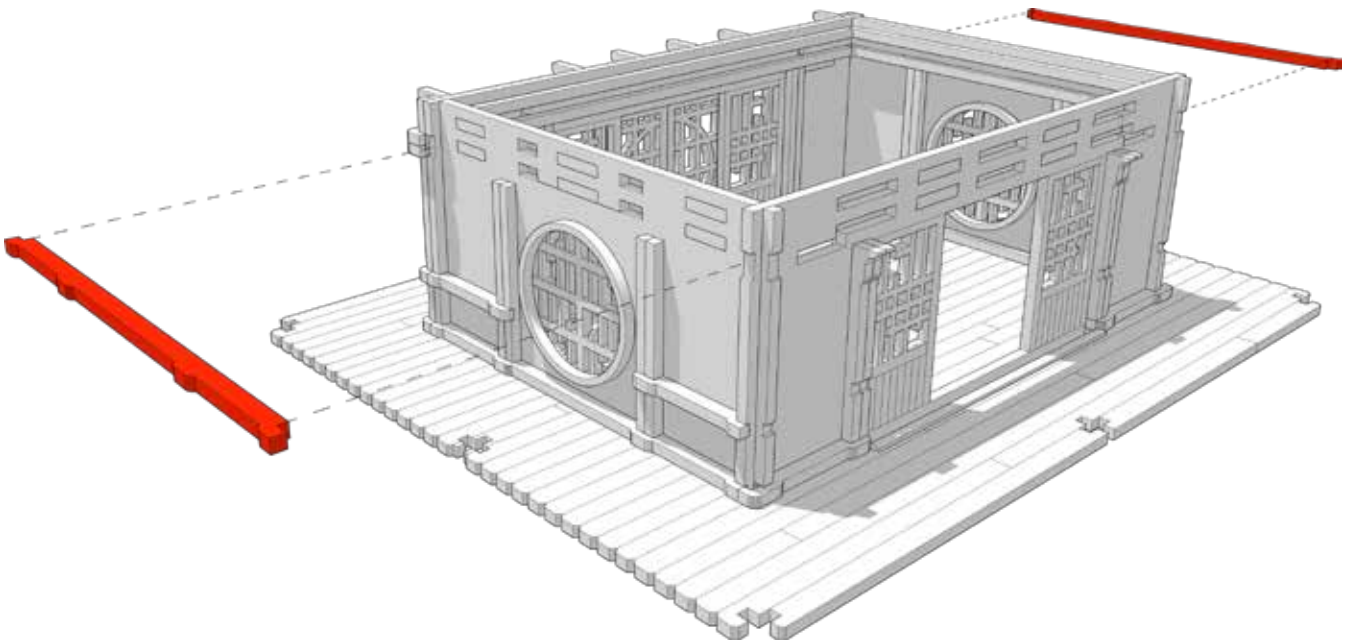

Repeat steps on both sides



TABLETOP SCENICS

TTSCW-EES-115
Toshi:
Dojo

40

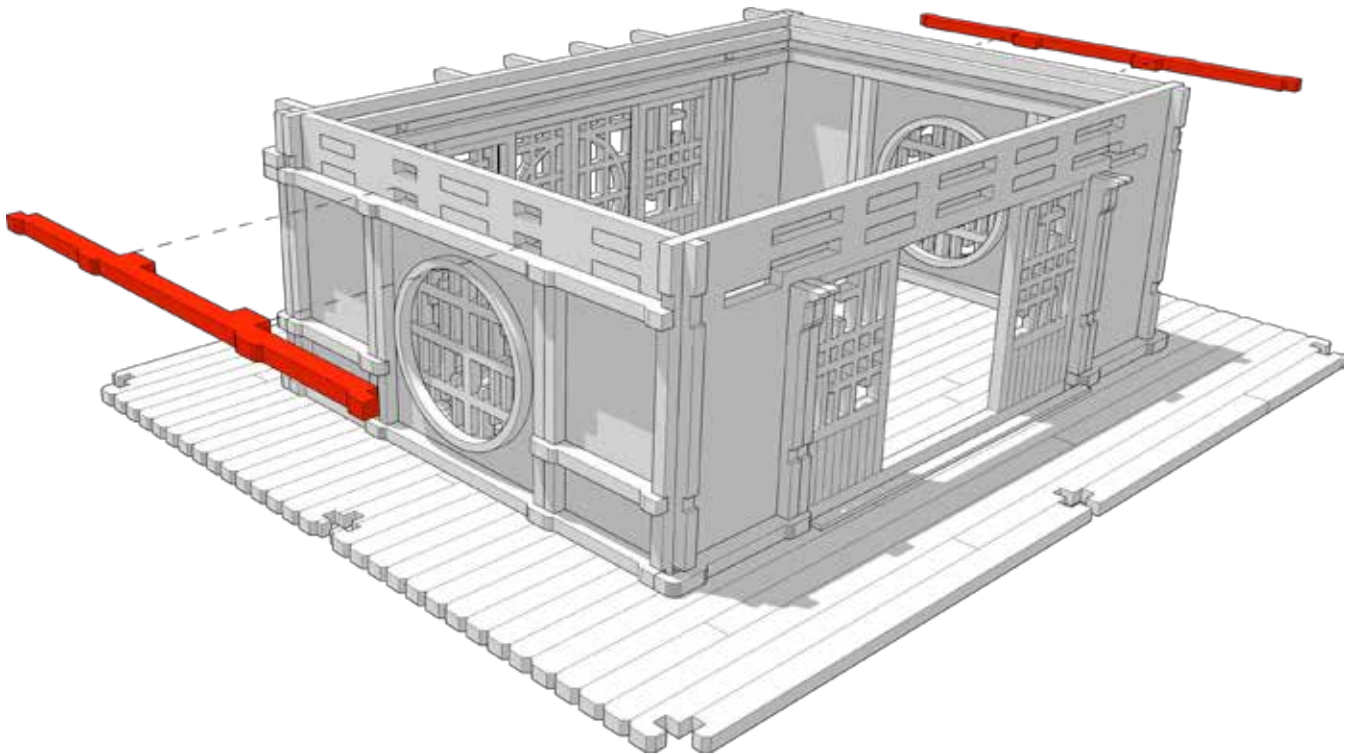

Repeat steps on both sides



TABLETOP SCENICS

TTSCW-EES-115
Toshi:
Dojo

41

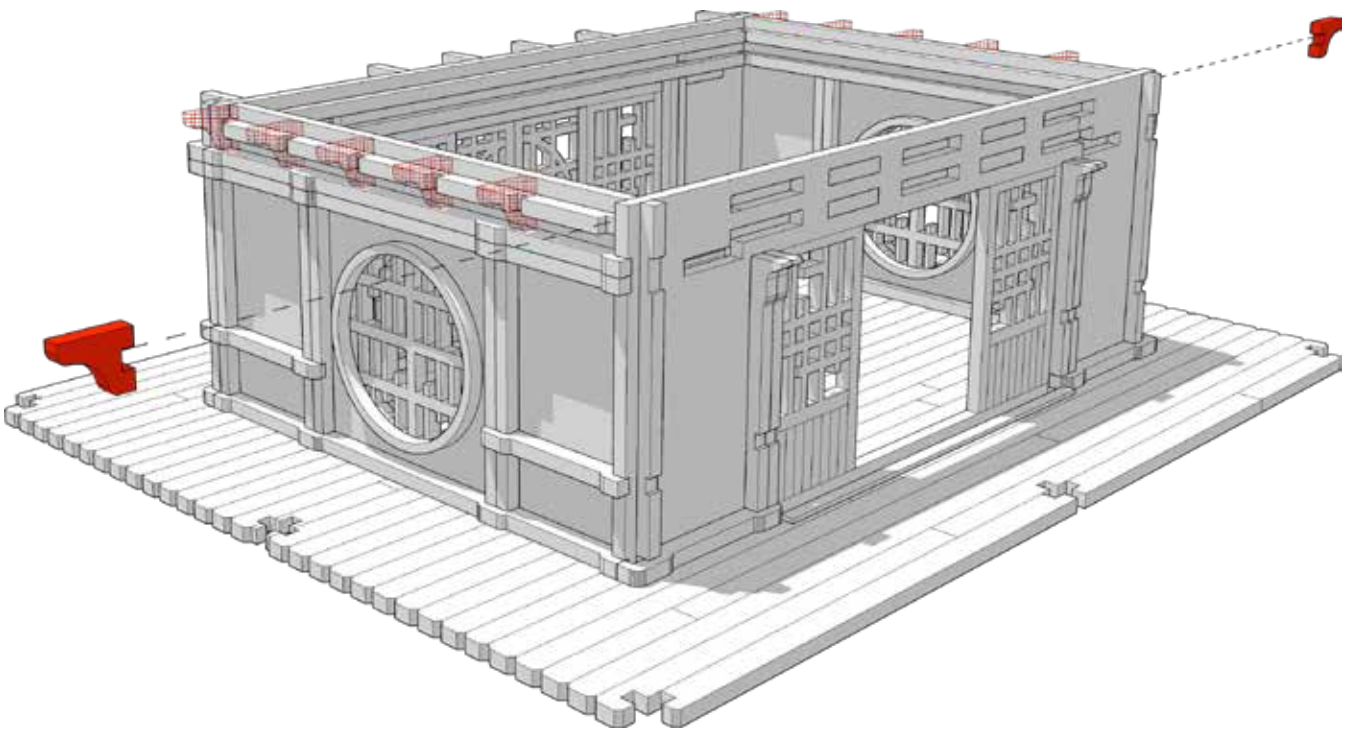

Repeat steps on both sides



TABLETOP SCENICS

TTSCW-EES-115
Toshi:
Dojo

42

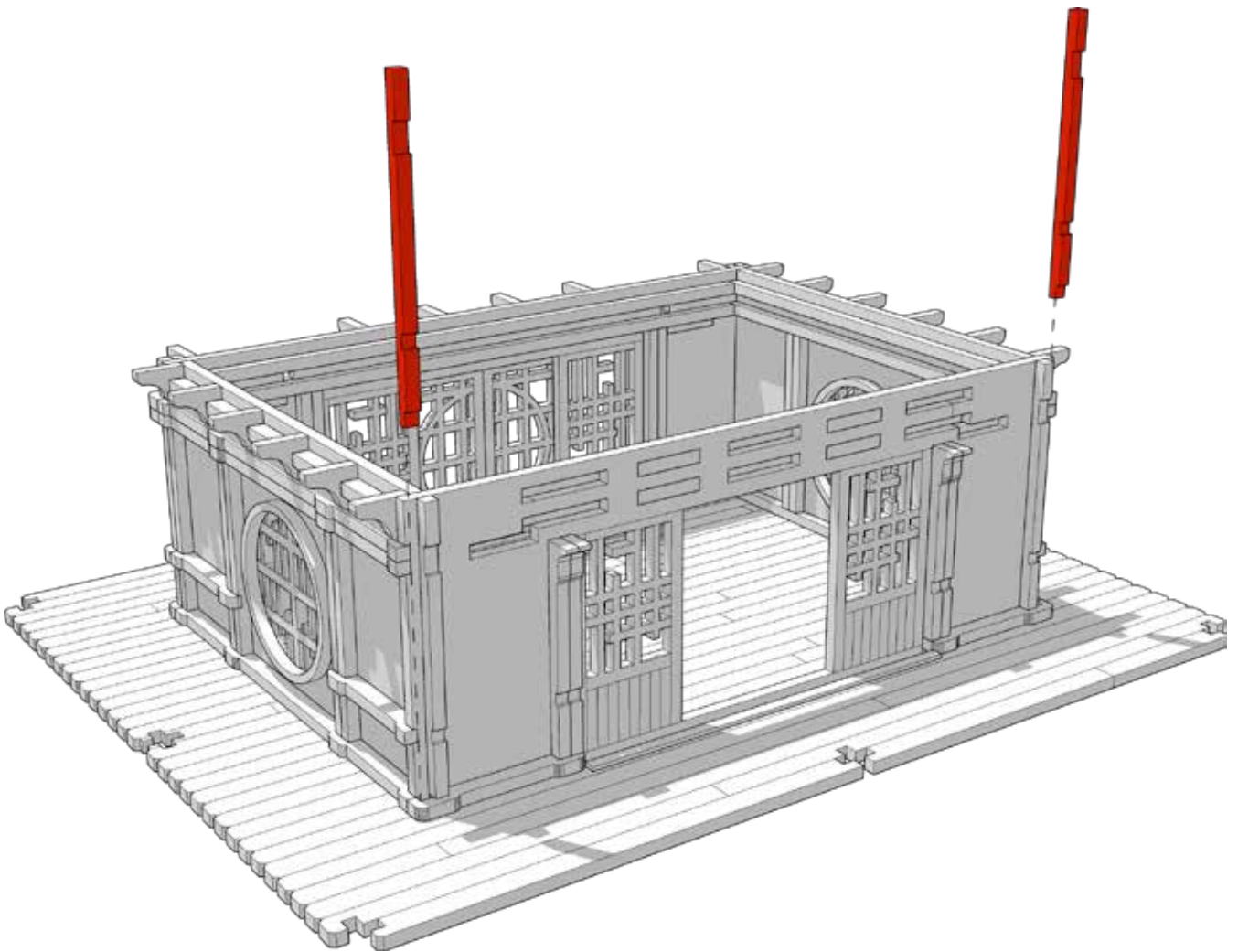



TABLETOP SCENICS

TTSCW-EES-115
Toshi:
Dojo

43

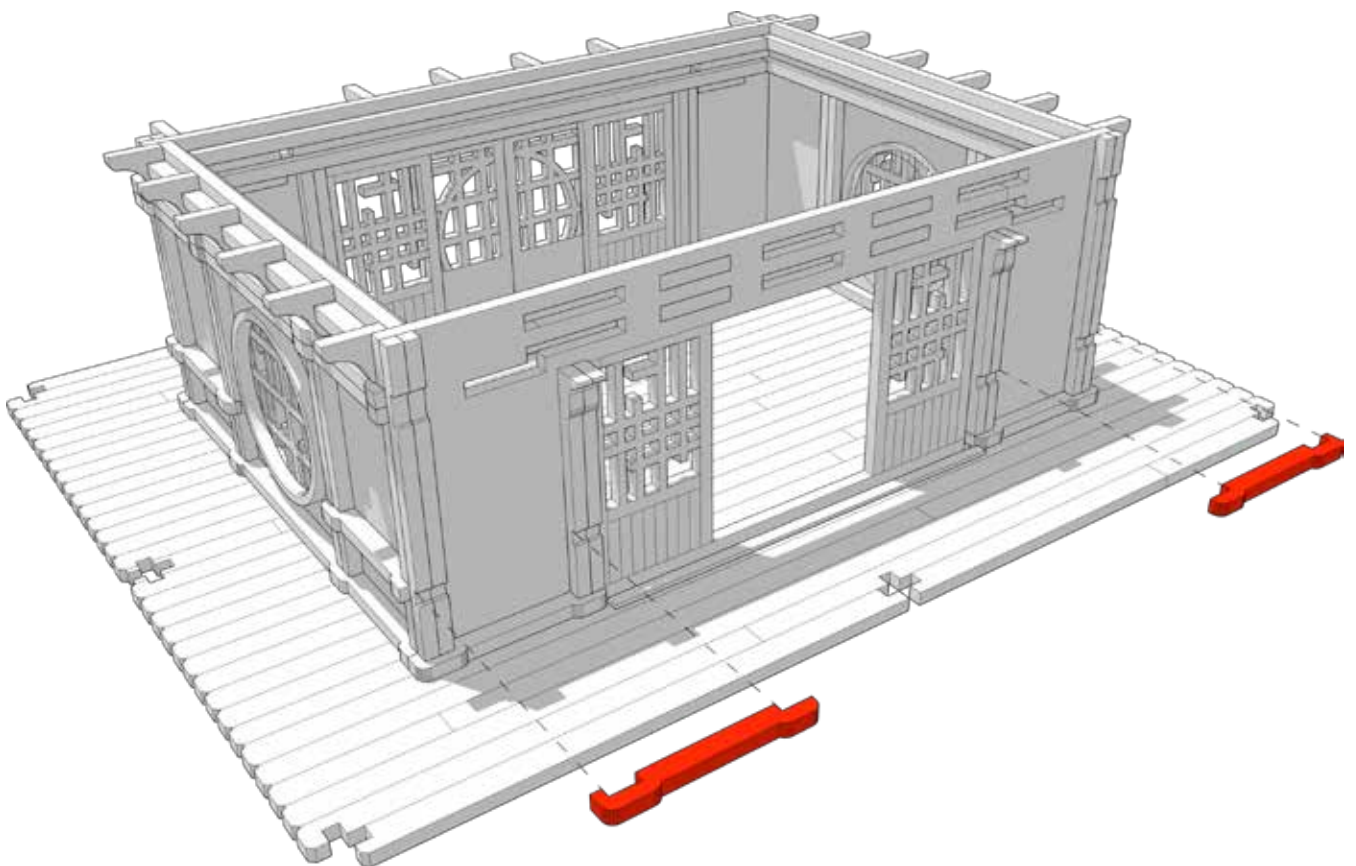



TABLETOP SCENICS

TTSCW-EES-115
Toshi:
Dojo

44

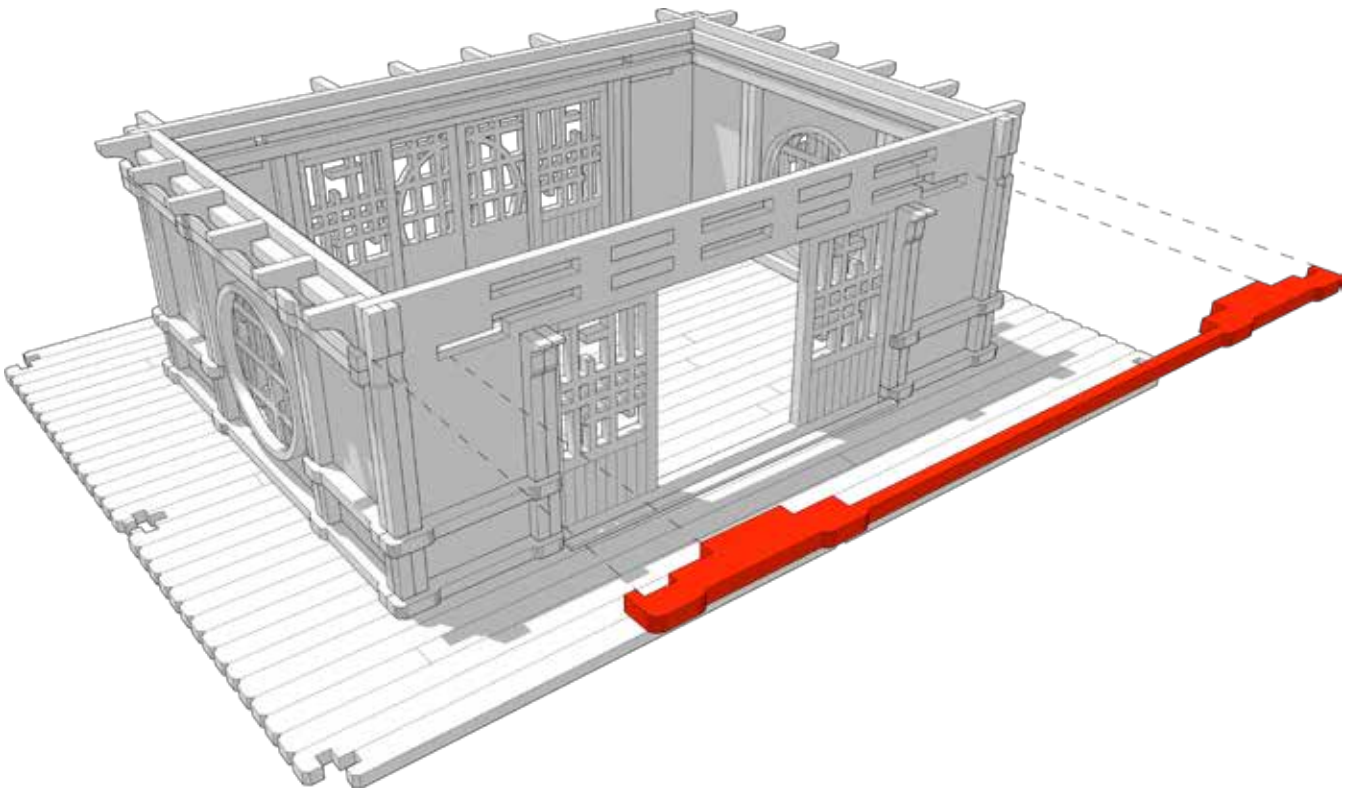



TABLETOP SCENICS

TTSCW-EES-115
Toshi:
Dojo

45

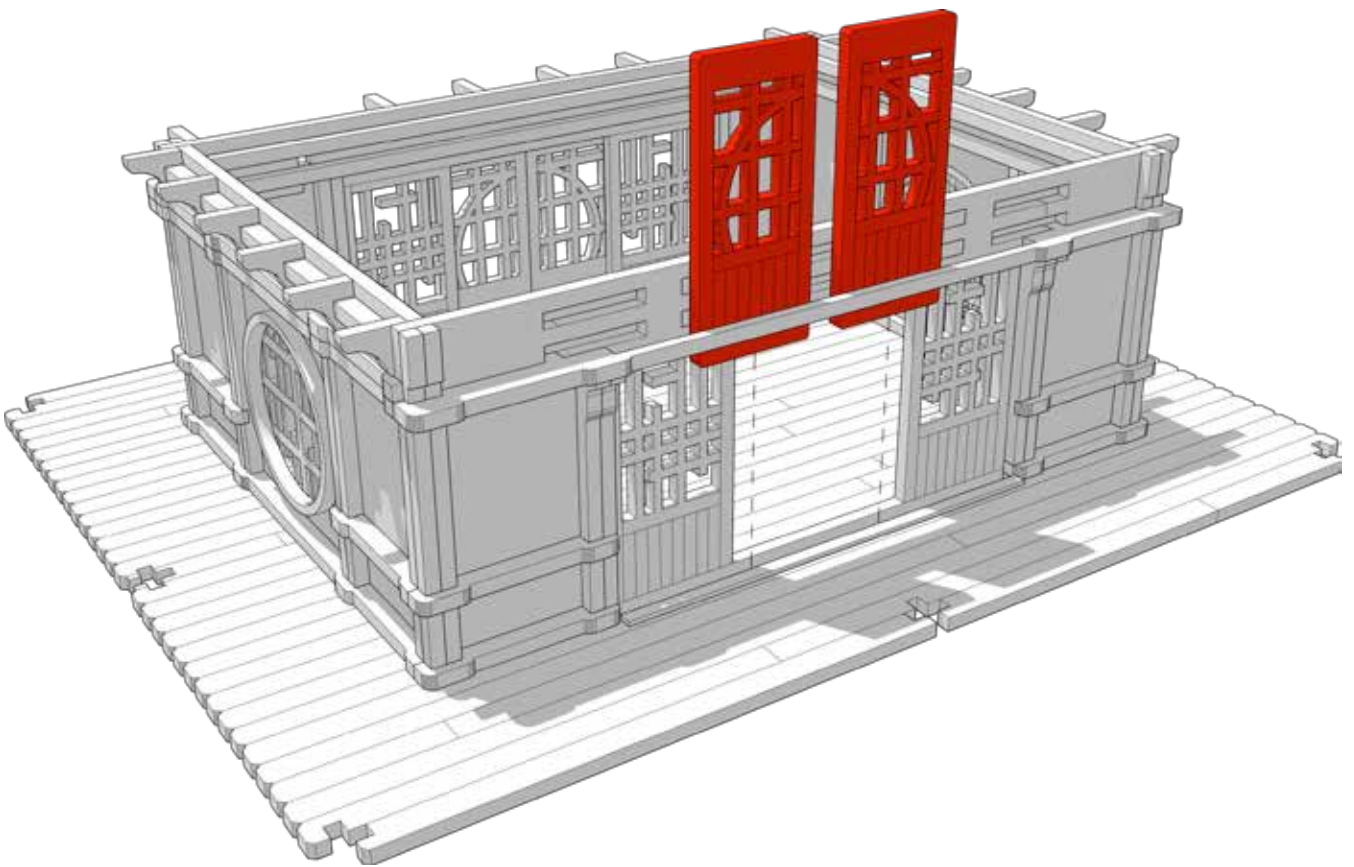

Do NOT Glue, doors should move freely in the lower slot and behind the previous placed part





TABLETOP SCENICS

TTSCW-EES-115
Toshi:
Dojo

46

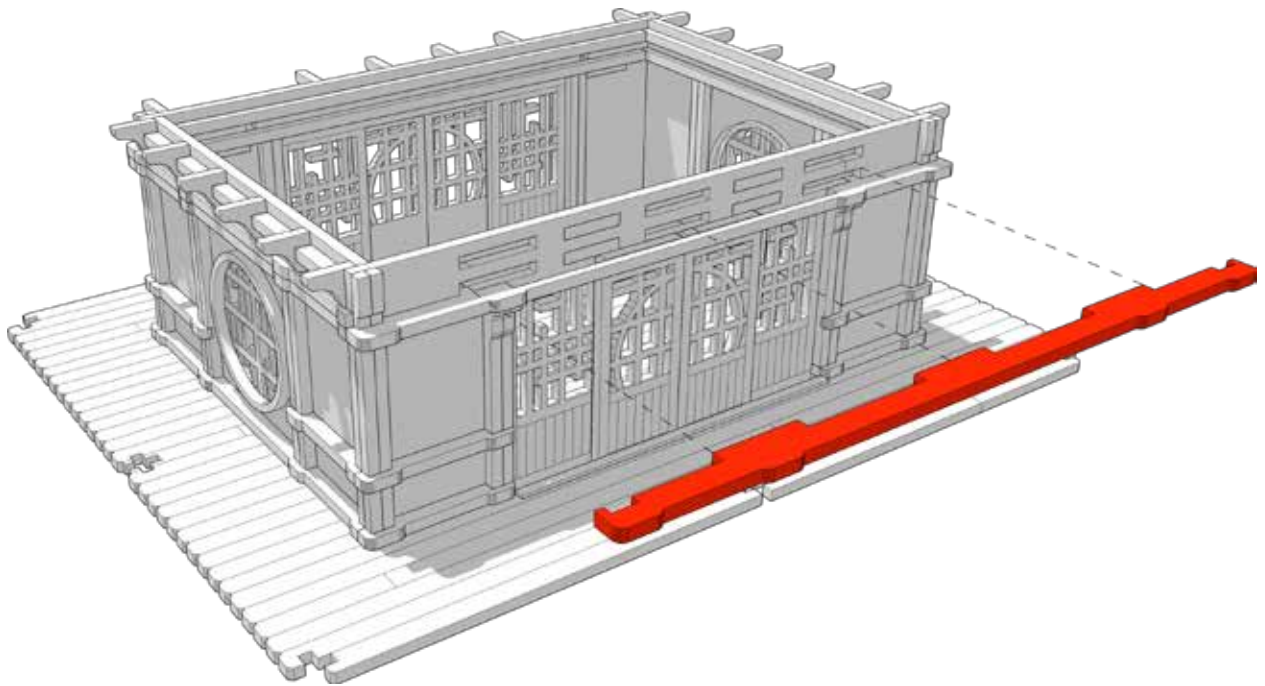

Do NOT get glue where the doors touch and
slide



 **TTCOMBAT**



TABLETOP SCENICS

TTSCW-EES-115
Toshi:
Dojo

47

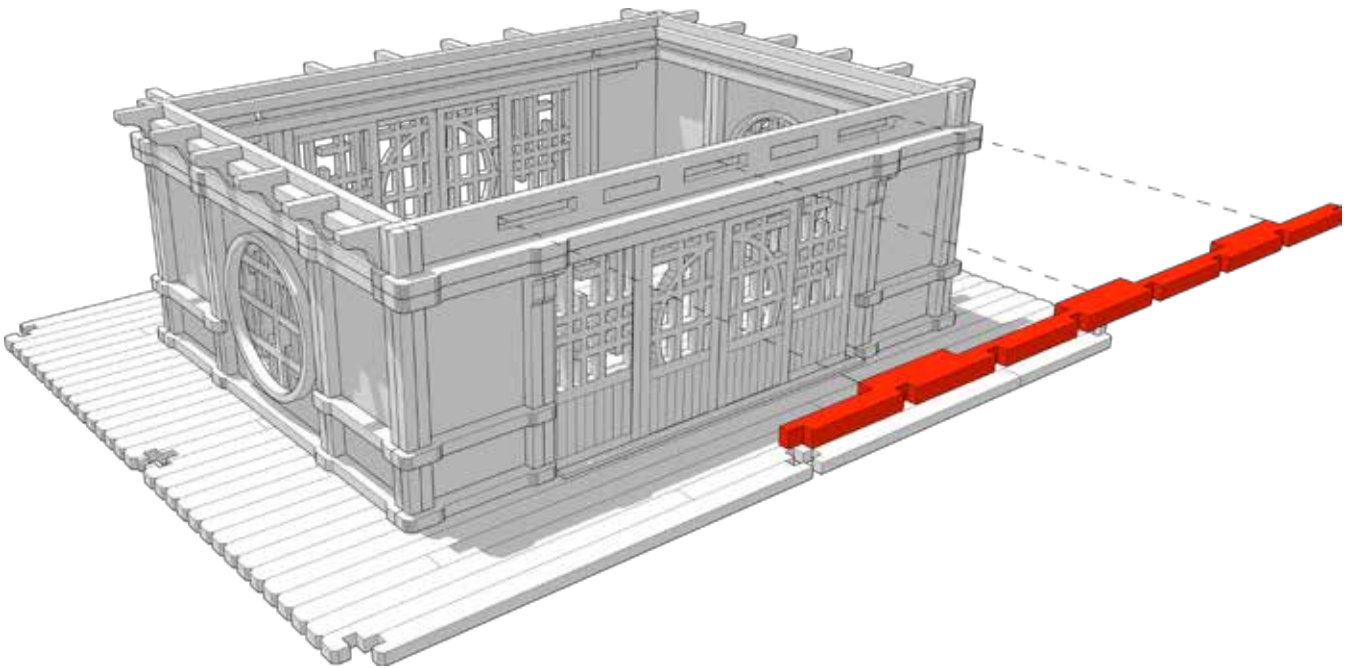



TABLETOP SCENICS

TTSCW-EES-115
Toshi:
Dojo

48

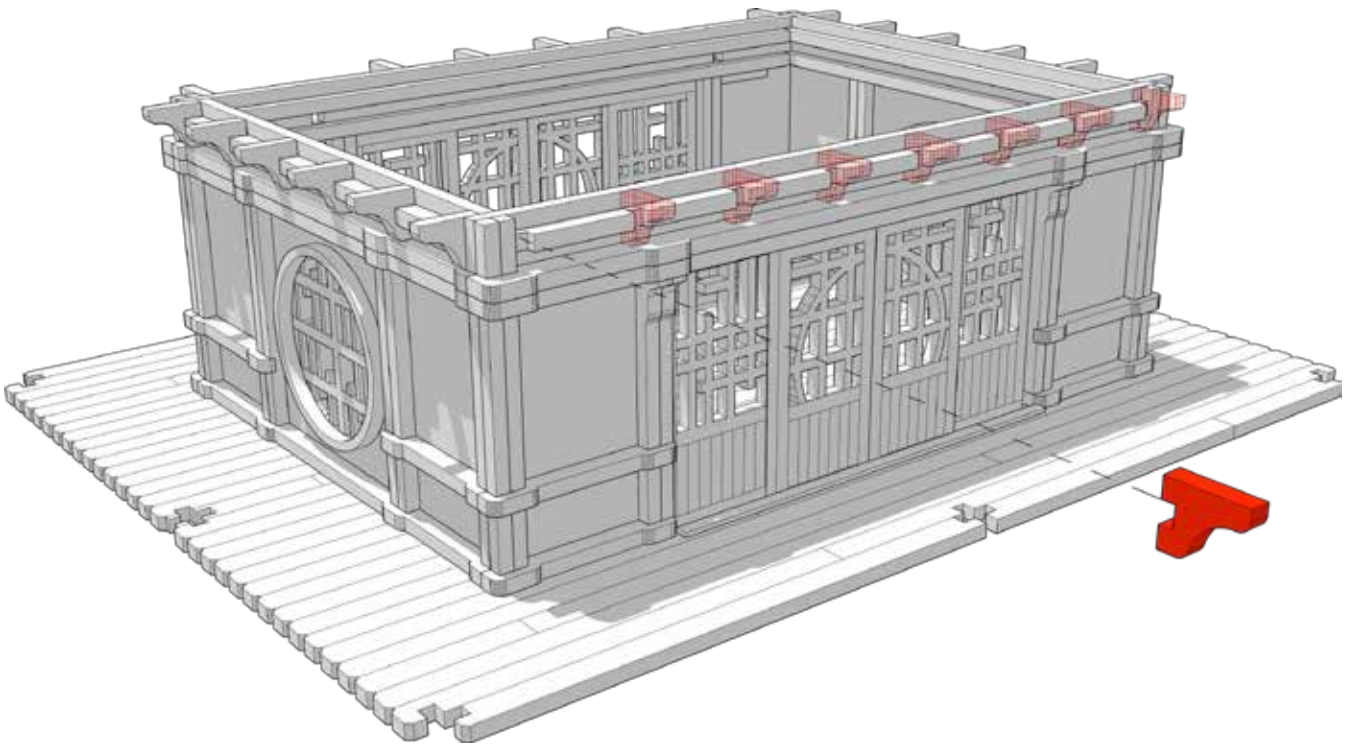



TABLETOP SCENICS

TTSCW-EES-115
Toshi:
Dojo

49

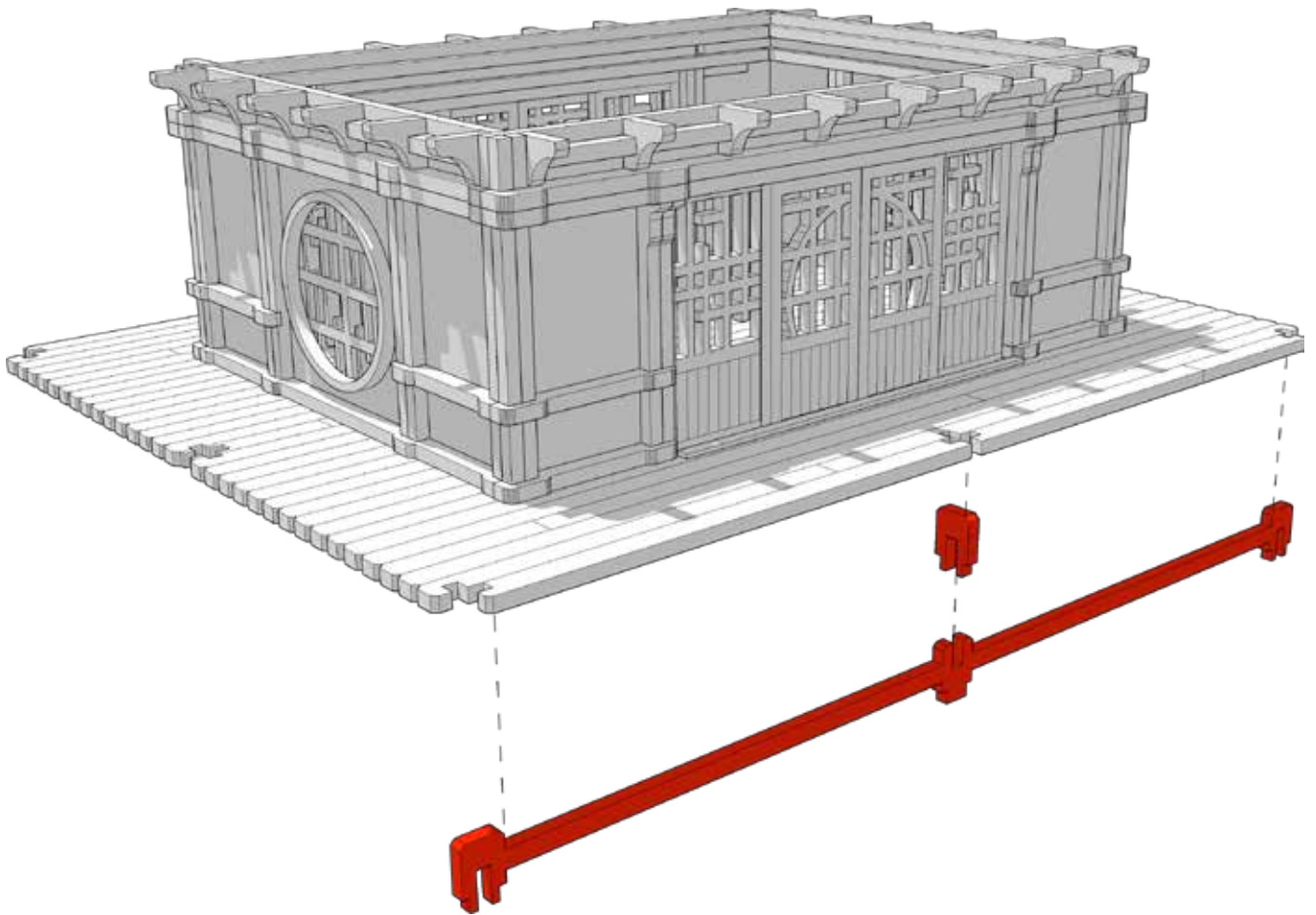



TABLETOP SCENICS

TTSCW-EES-115
Toshi:
Dojo

50

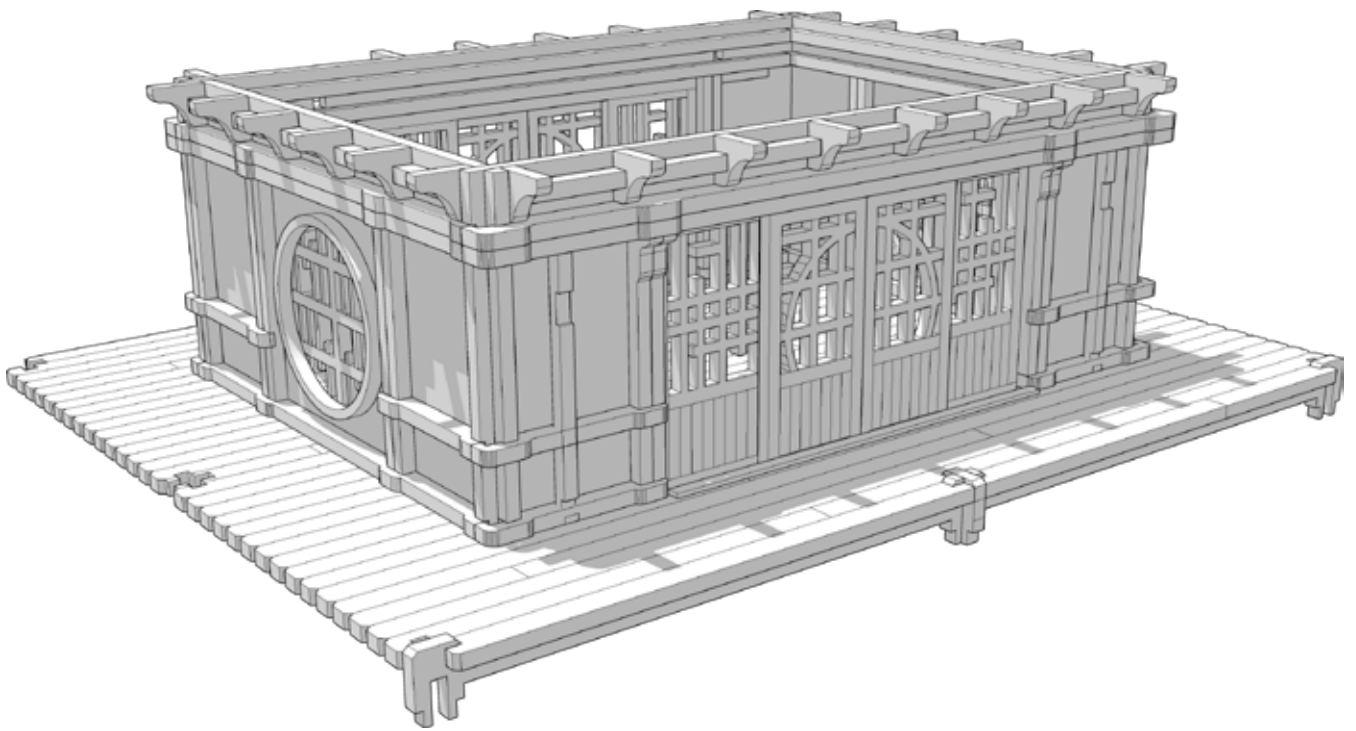



TABLETOP SCENICS

TTSCW-EES-115
Toshi:
Dojo

51

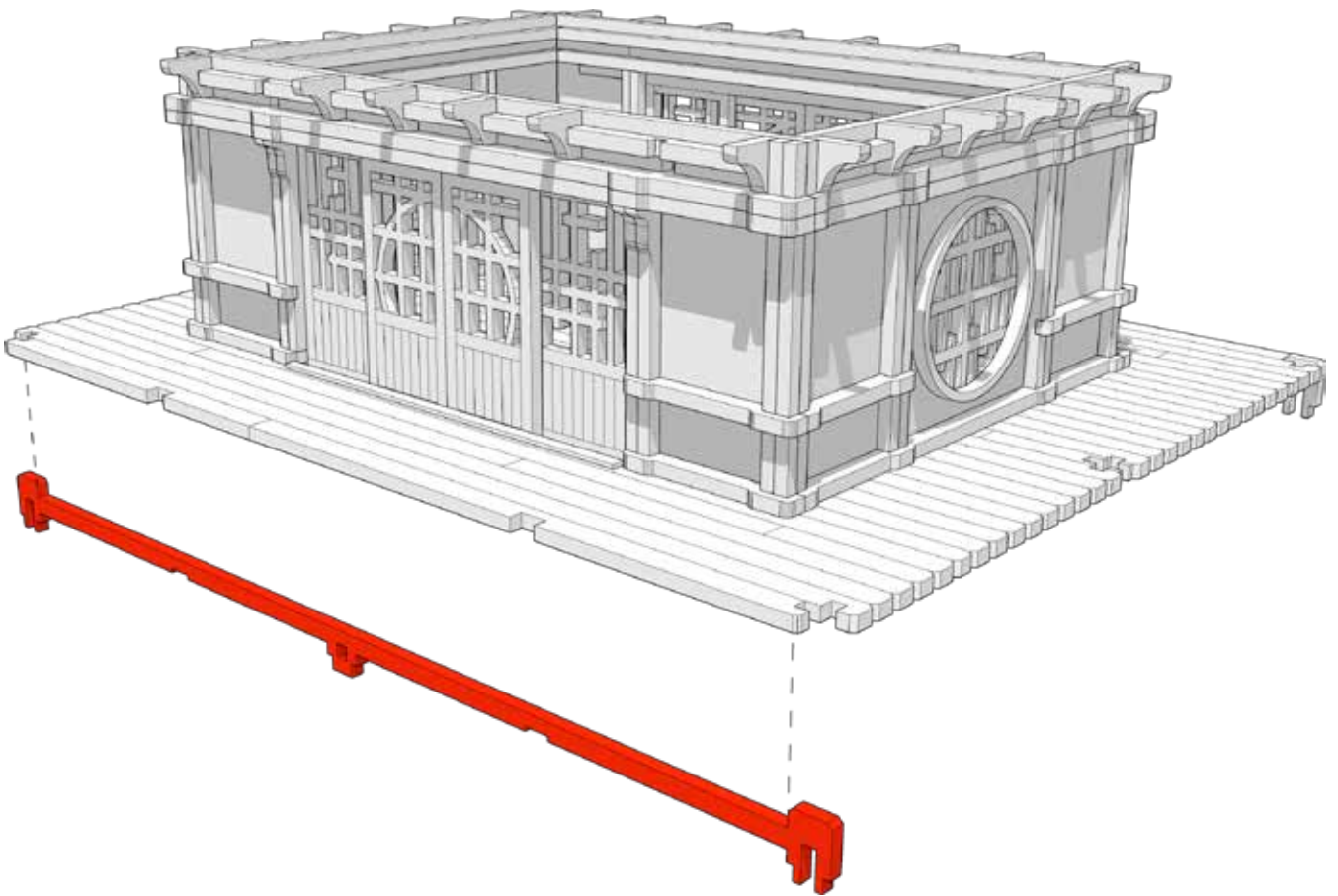



TABLETOP SCENICS

TTSCW-EES-115
Toshi:
Dojo

52

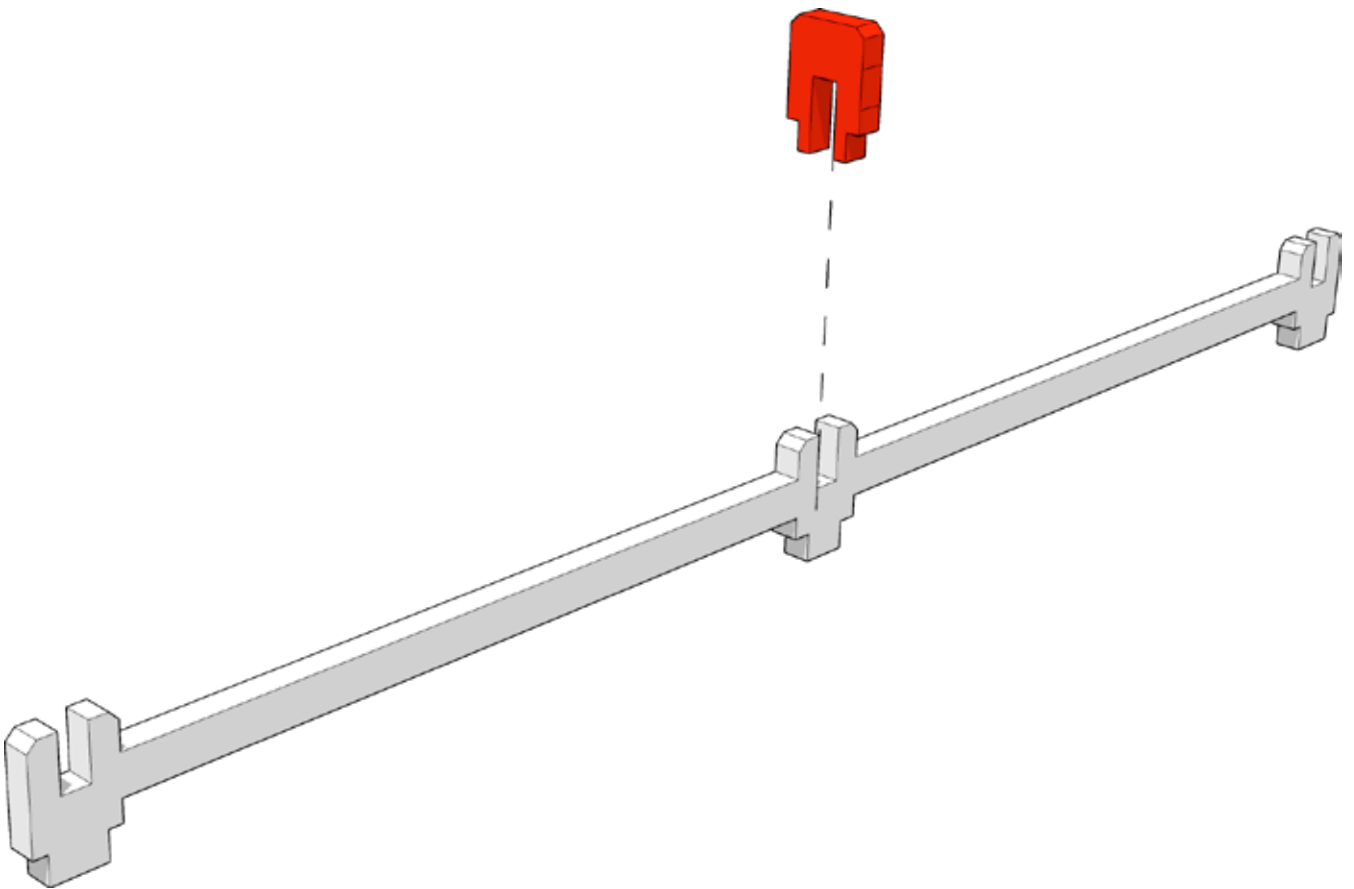



TABLETOP SCENICS

TTSCW-EES-115
Toshi:
Dojo

53

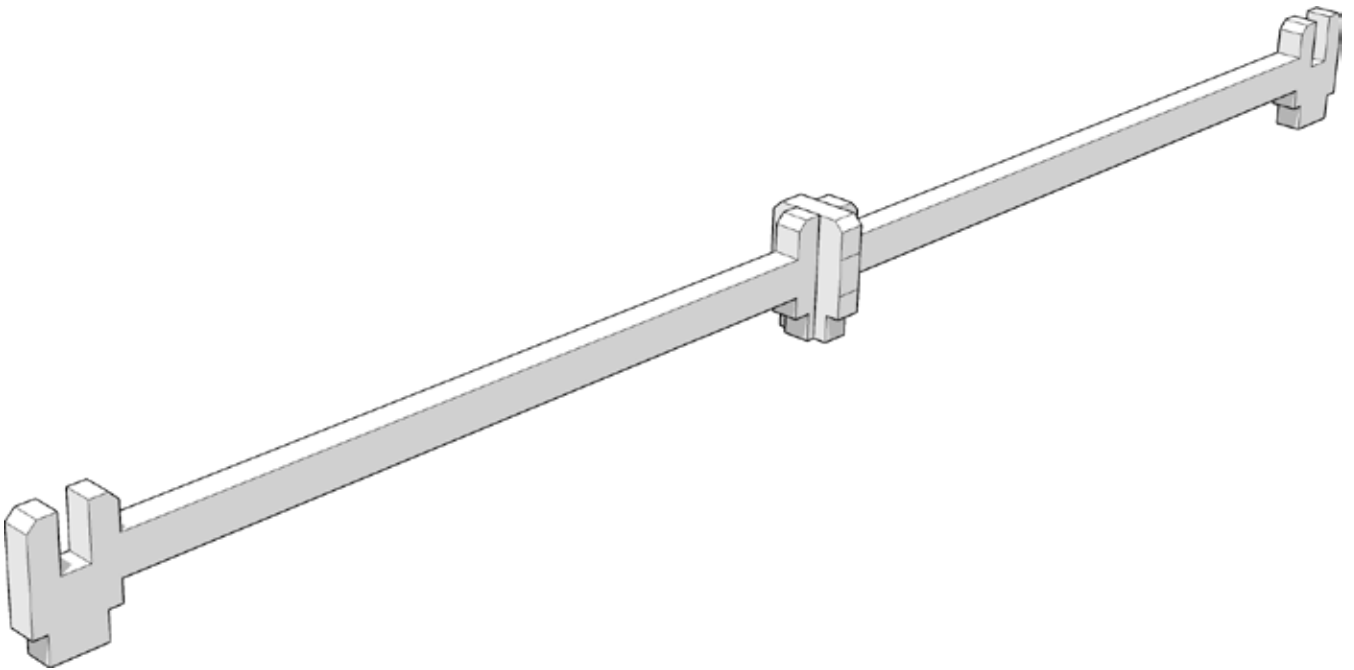



TABLETOP SCENICS

TTSCW-EES-115
Toshi:
Dojo

54

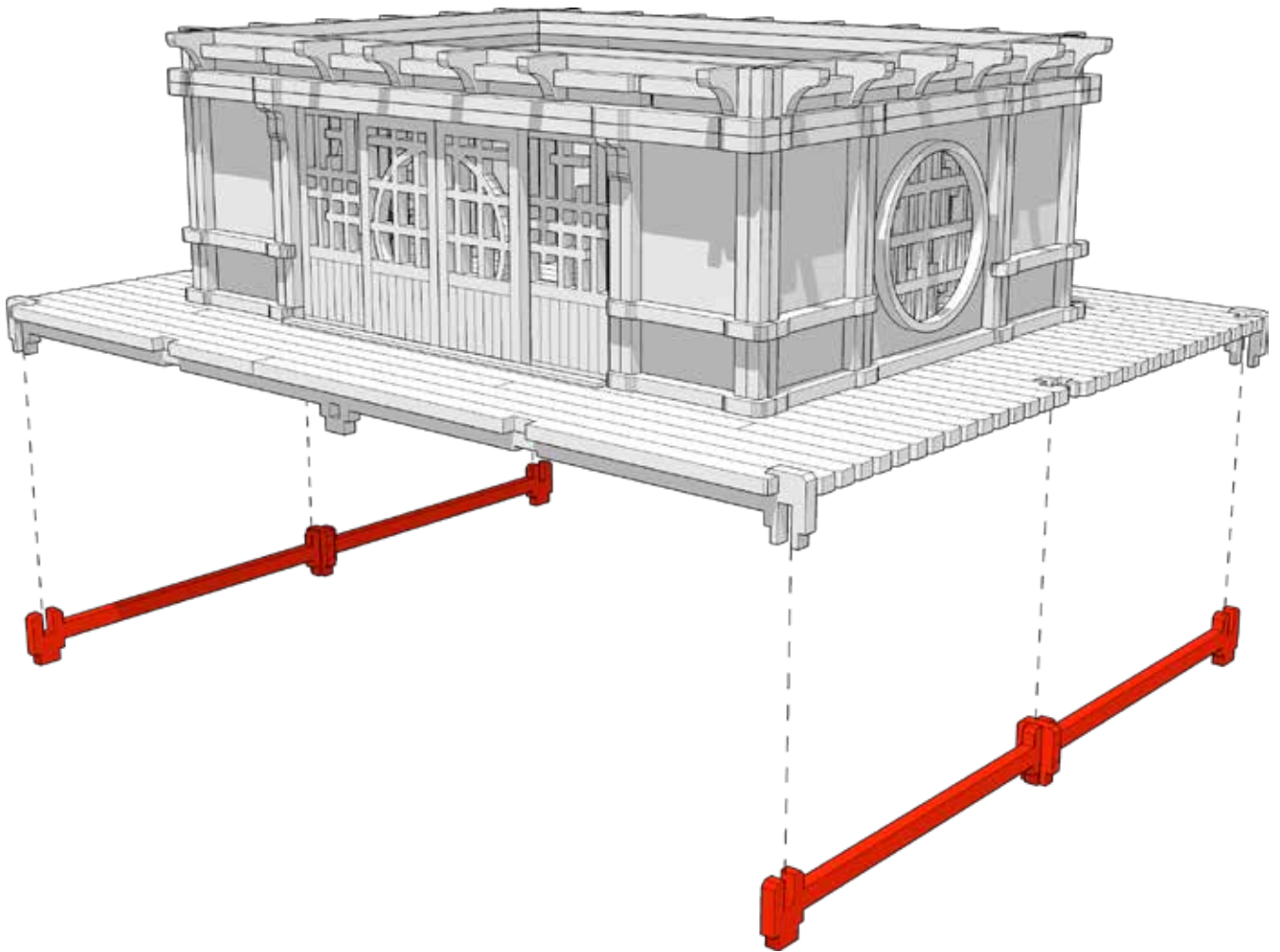



TABLETOP SCENICS

TTSCW-EES-115
Toshi:
Dojo

55

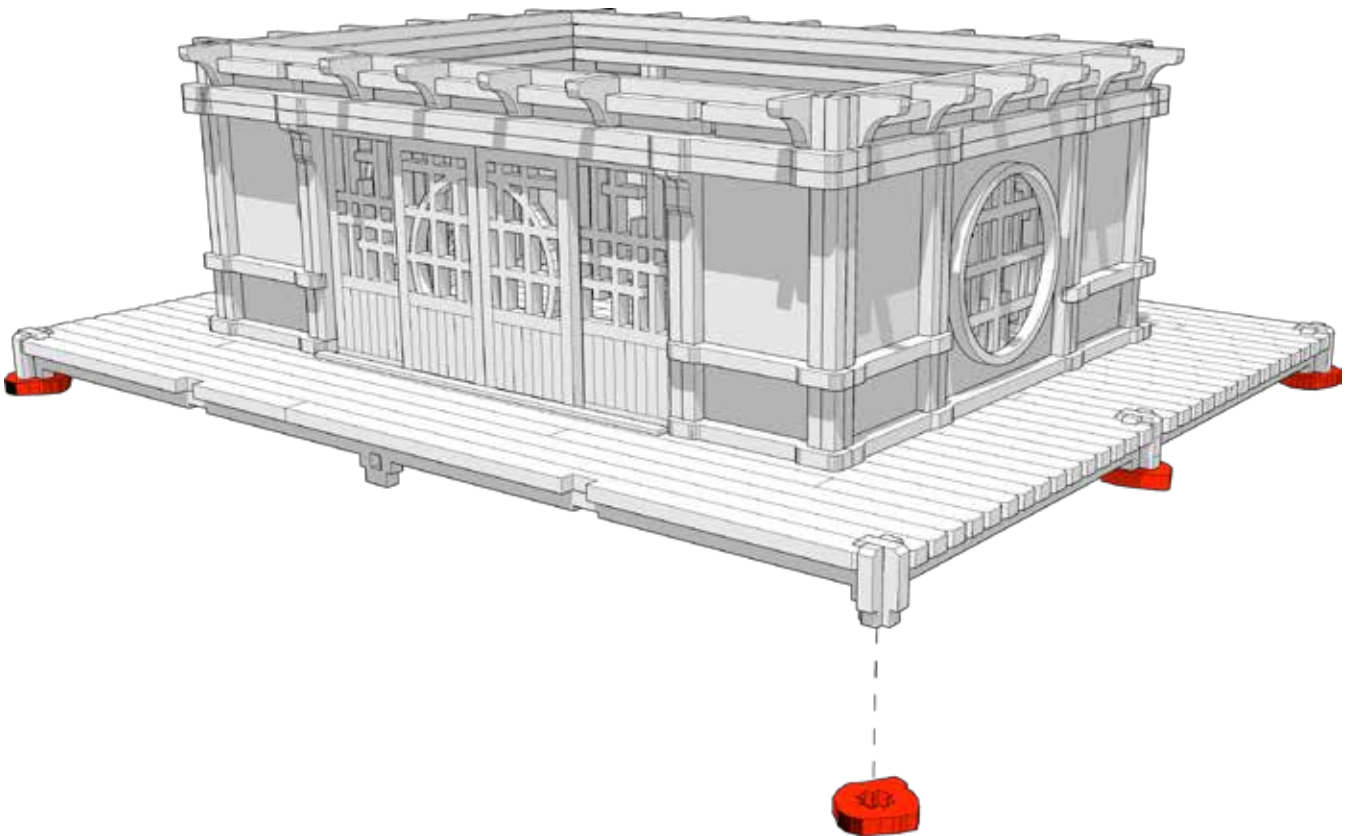

Highlighted parts are similar and can be placed to personal preference.
NOTE: There are two larger pieces that are similar but are used for step



 **TTCOMBAT**



TABLETOP SCENICS

TTSCW-EES-115
Toshi:
Dojo

56

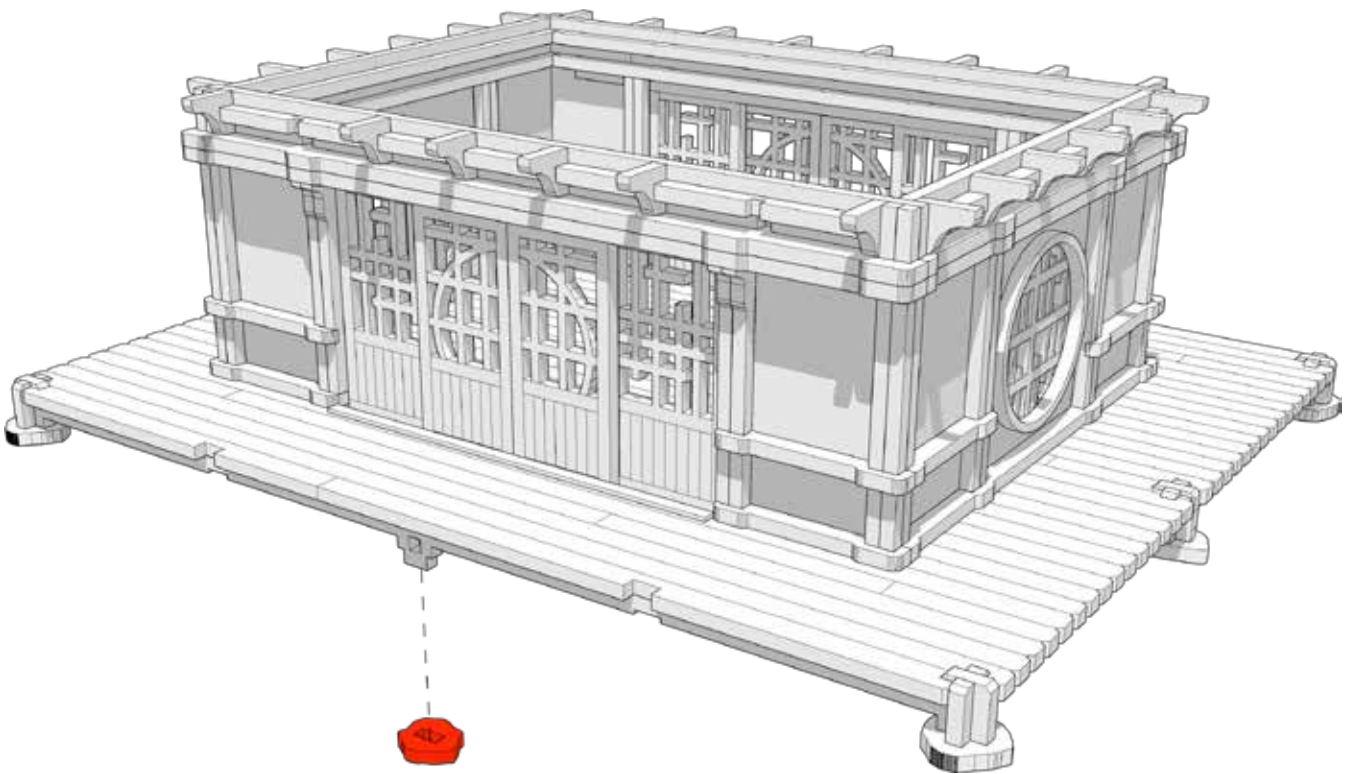



TABLETOP SCENICS

TTSCW-EES-115
Toshi:
Dojo

57

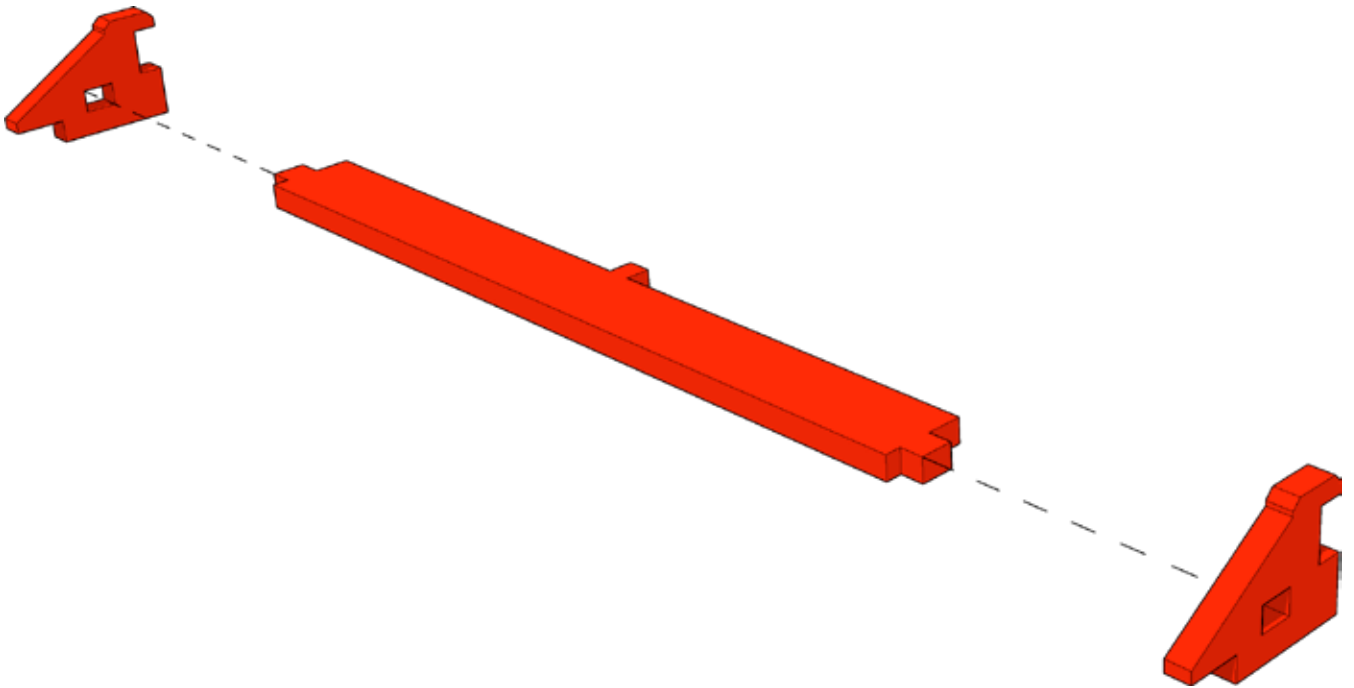



TABLETOP SCENICS

TTSCW-EES-115
Toshi:
Dojo

58

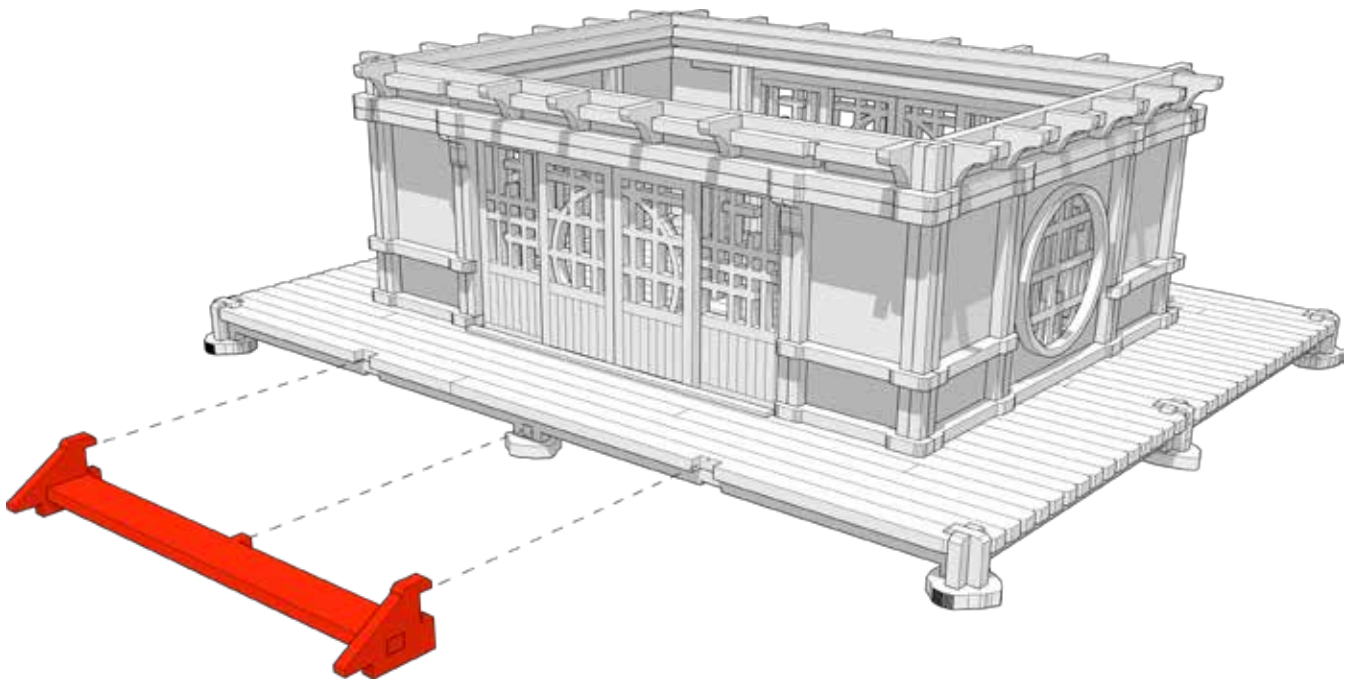



TABLETOP SCENICS

TTSCW-EES-115
Toshi:
Dojo

59

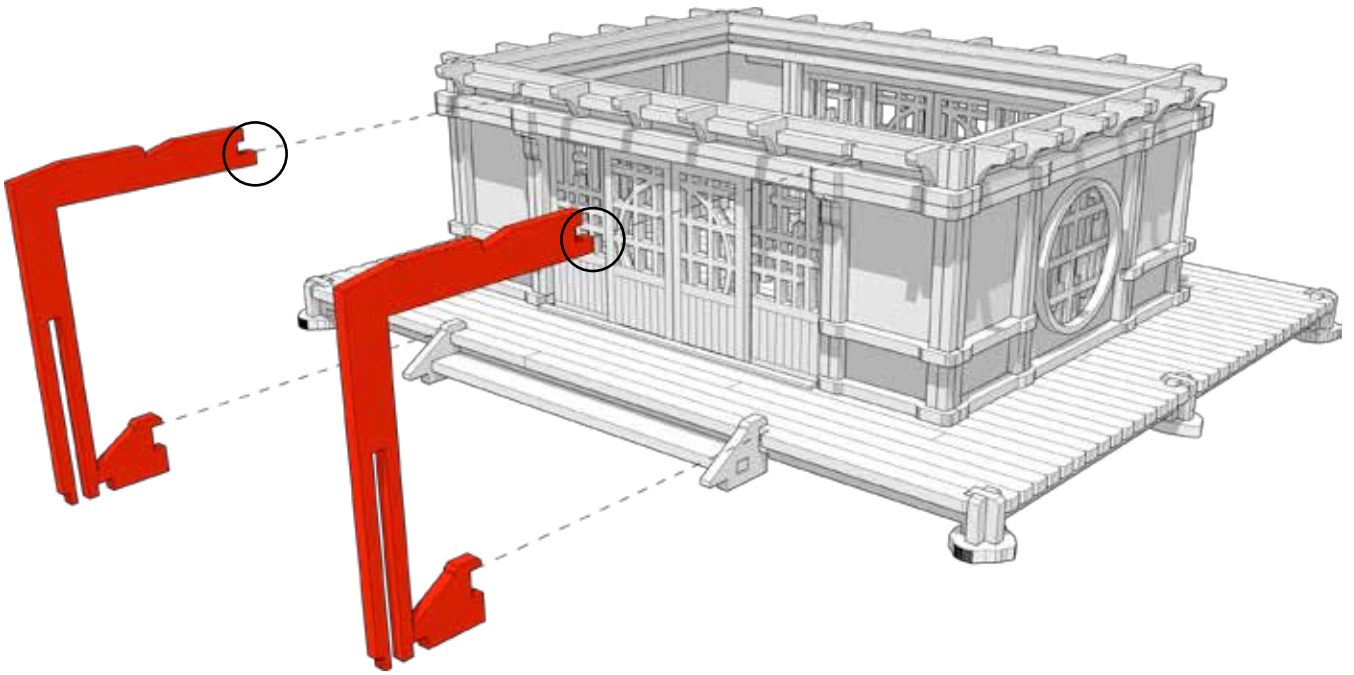

Circled tabs connect into the gap into the wall slot, as noted in the earlier steps



TABLETOP SCENICS

TTSCW-EES-115
Toshi:
Dojo

60

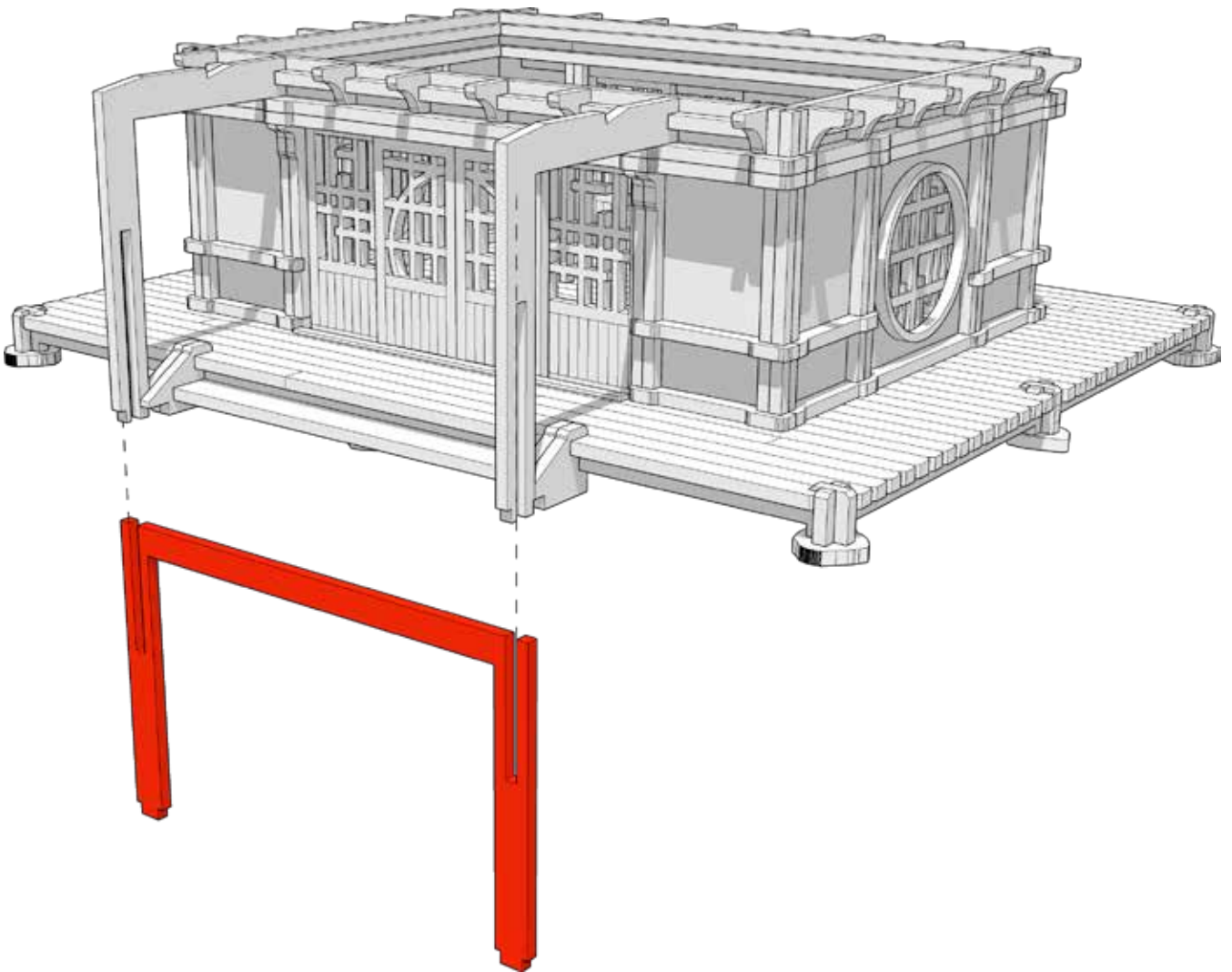



TABLETOP SCENICS

TTSCW-EES-115
Toshi:
Dojo

61

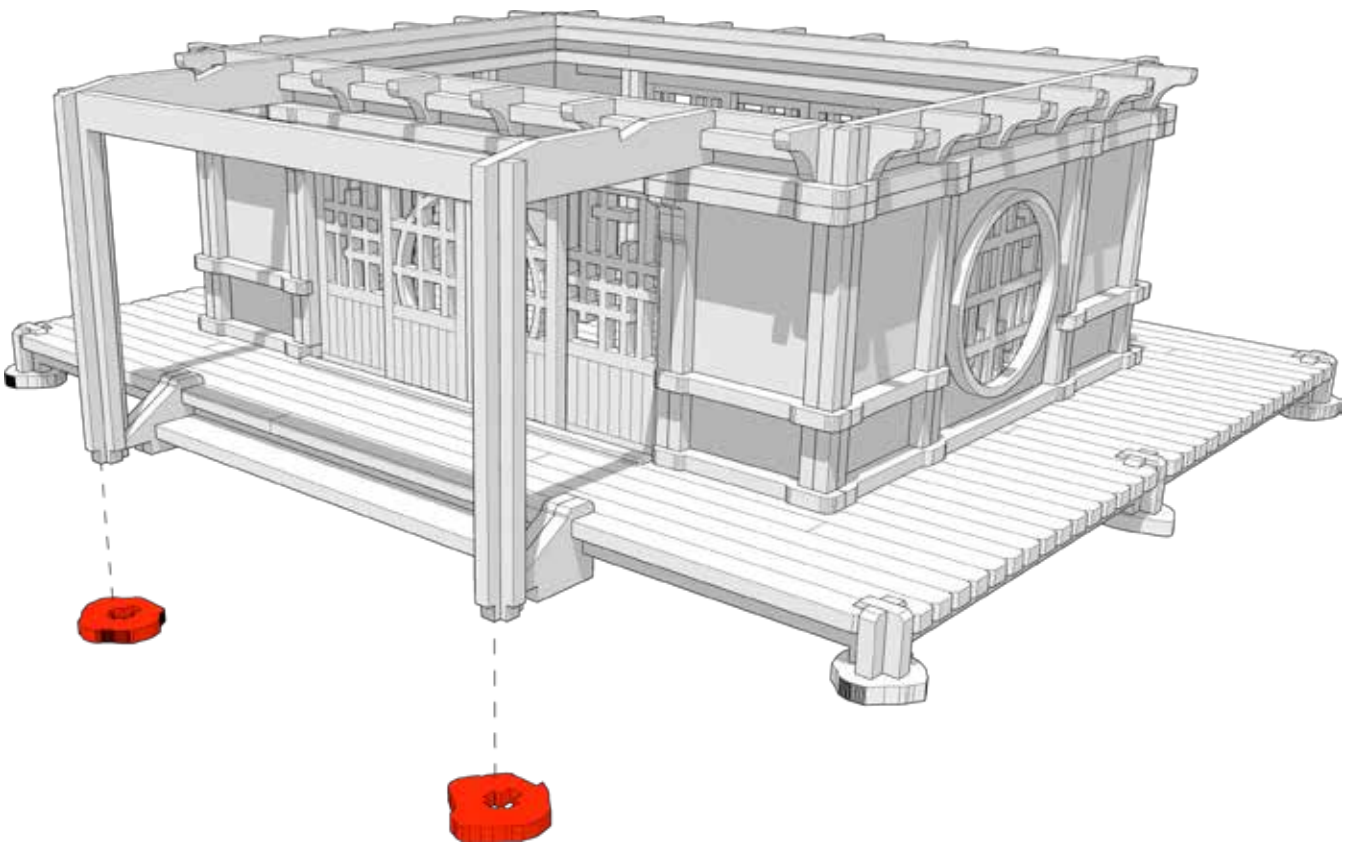



TABLETOP SCENICS

TTSCW-EES-115
Toshi:
Dojo

62

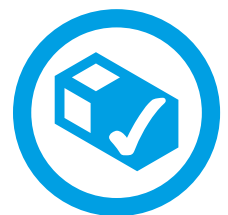
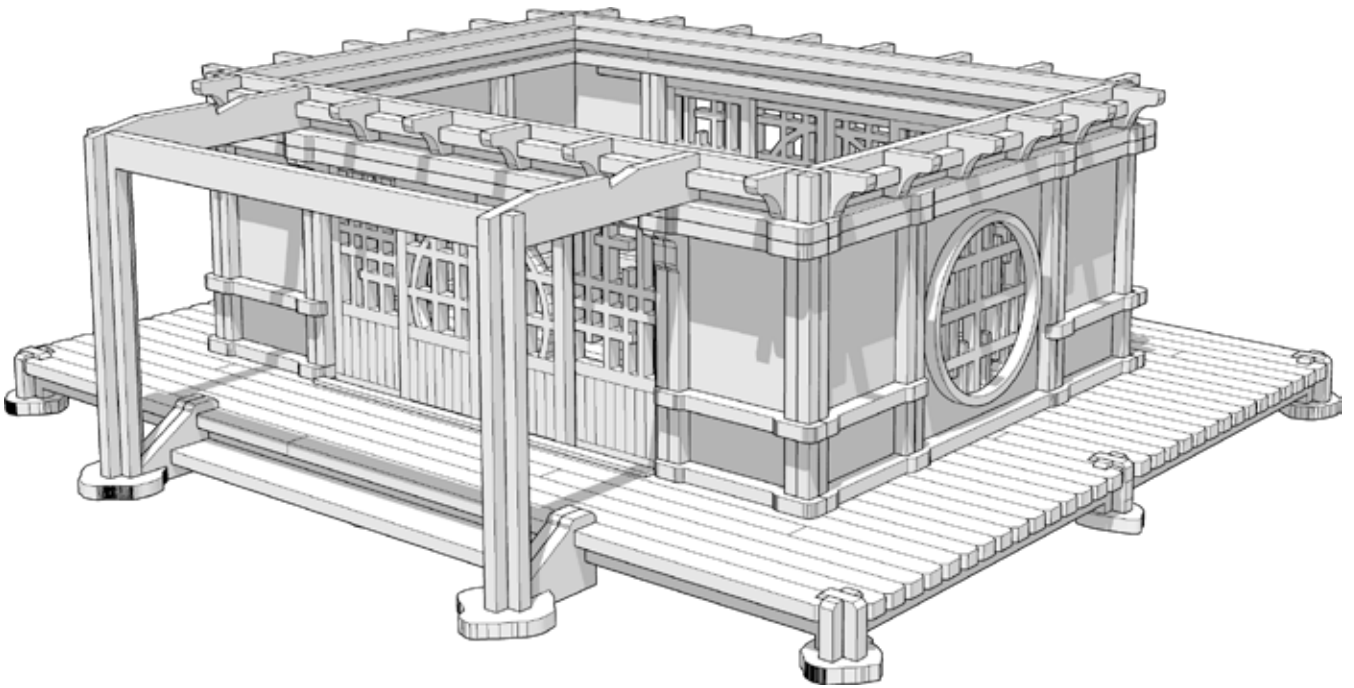

 **TTCOMBAT**



TABLETOP SCENICS

TTSCW-EES-115
Toshi:
Dojo

63

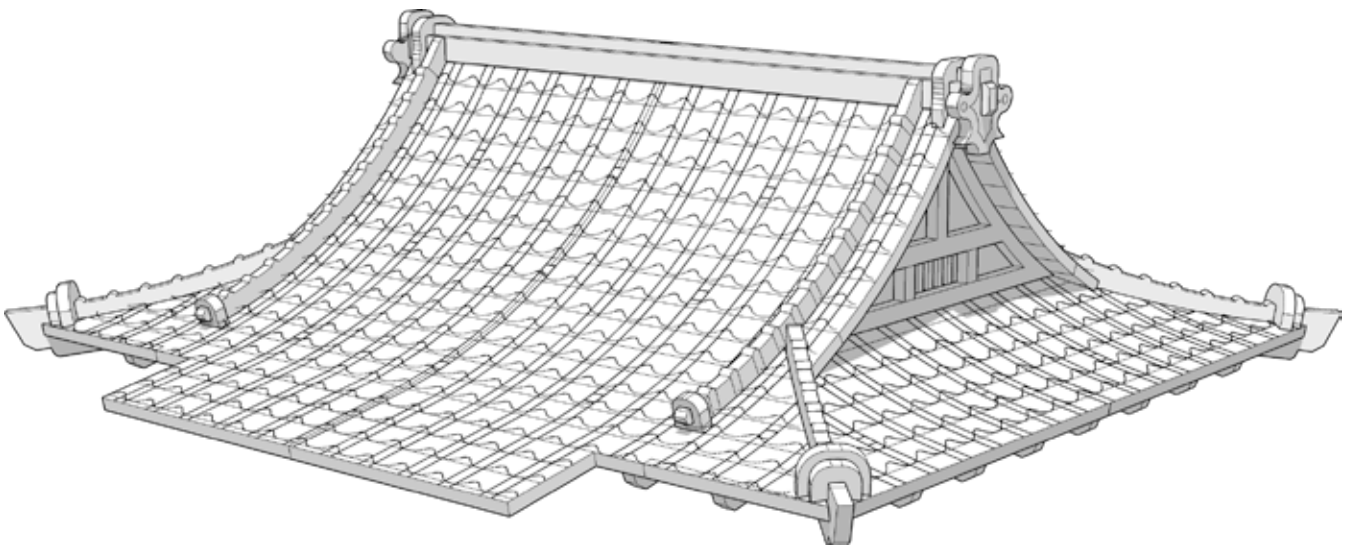

Dojo Roof



TABLETOP SCENICS

TTSCW-EES-115
Toshi:
Dojo

64

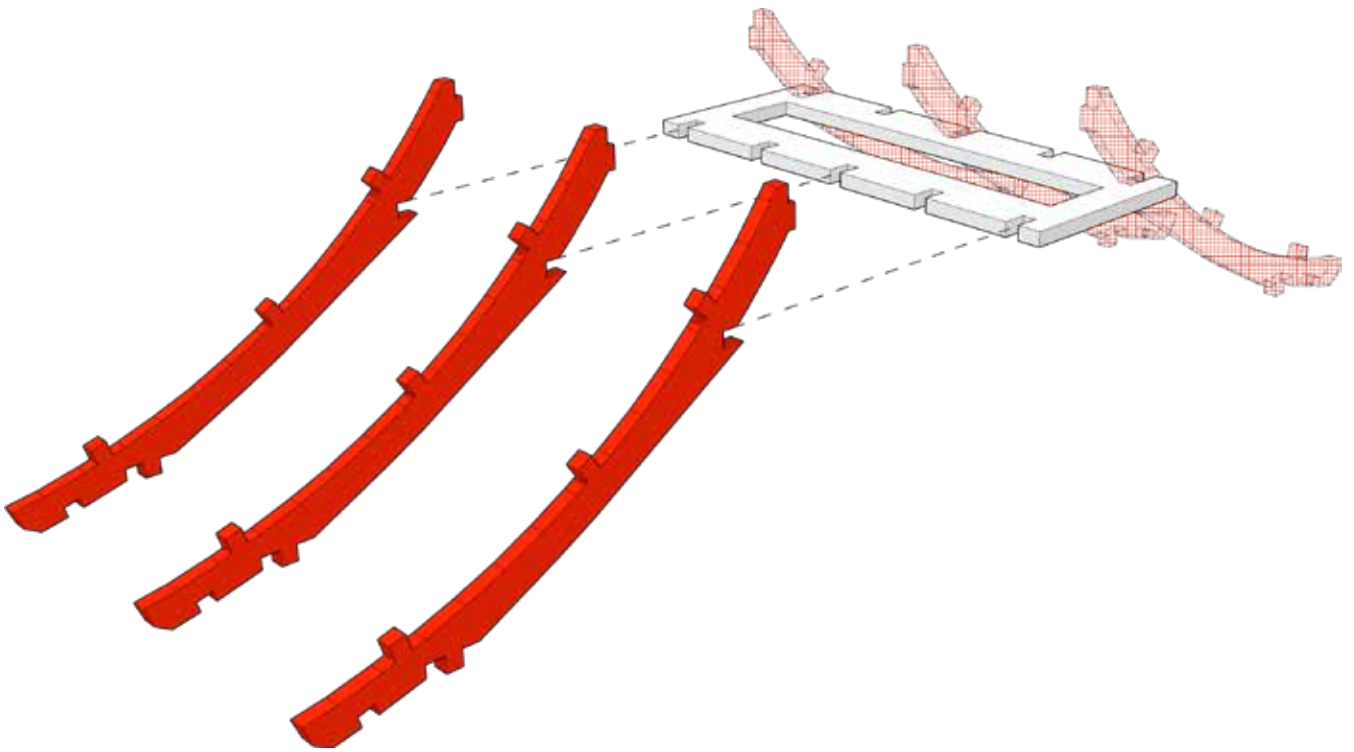

Repeat on both sides



TABLETOP SCENICS

TTSCW-EES-115
Toshi:
Dojo

65

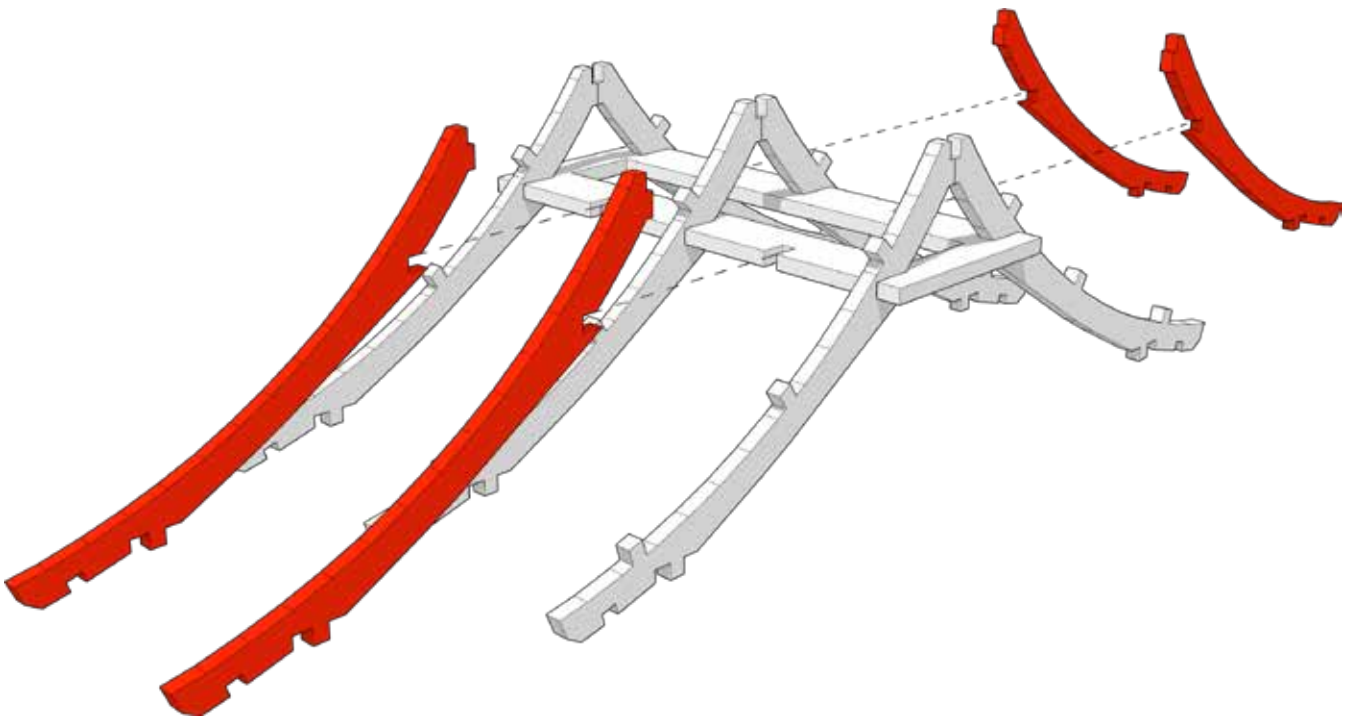



TABLETOP SCENICS

TTSCW-EES-115
Toshi:
Dojo

66

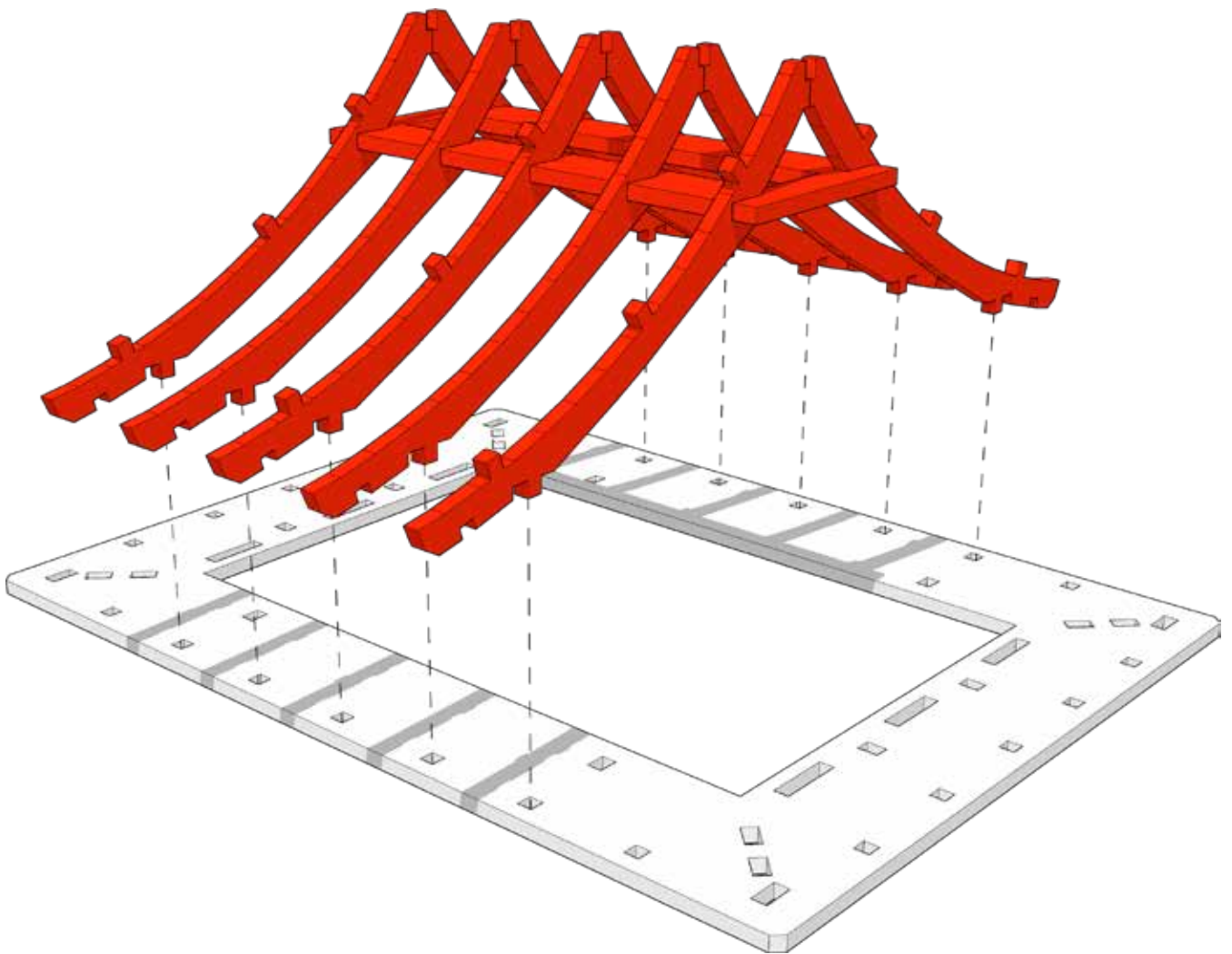



TABLETOP SCENICS

TTSCW-EES-115
Toshi:
Dojo

67

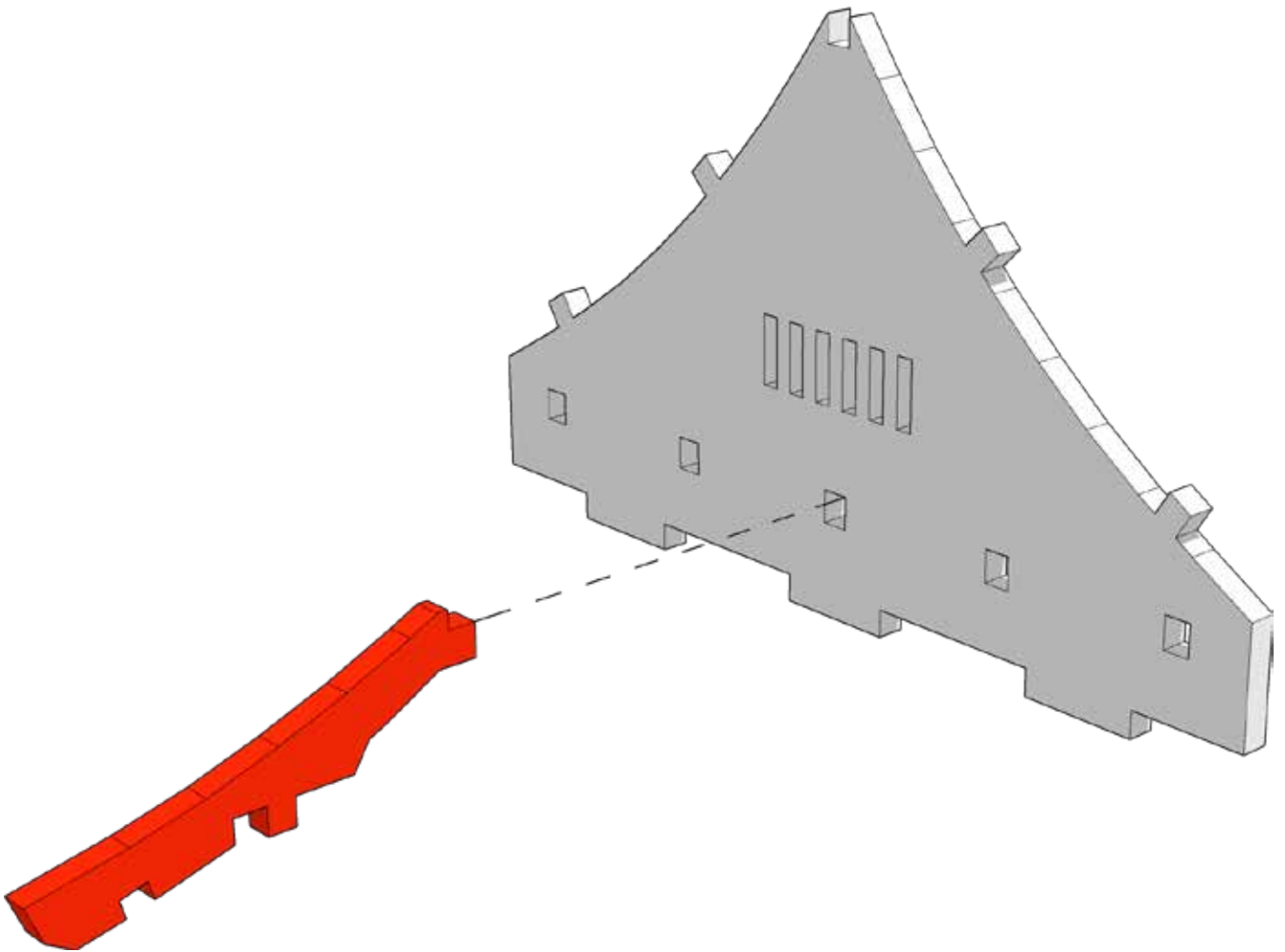

Highlighted part is similar to other parts but there are only 2



TABLETOP SCENICS

TTSCW-EES-115
Toshi:
Dojo

68

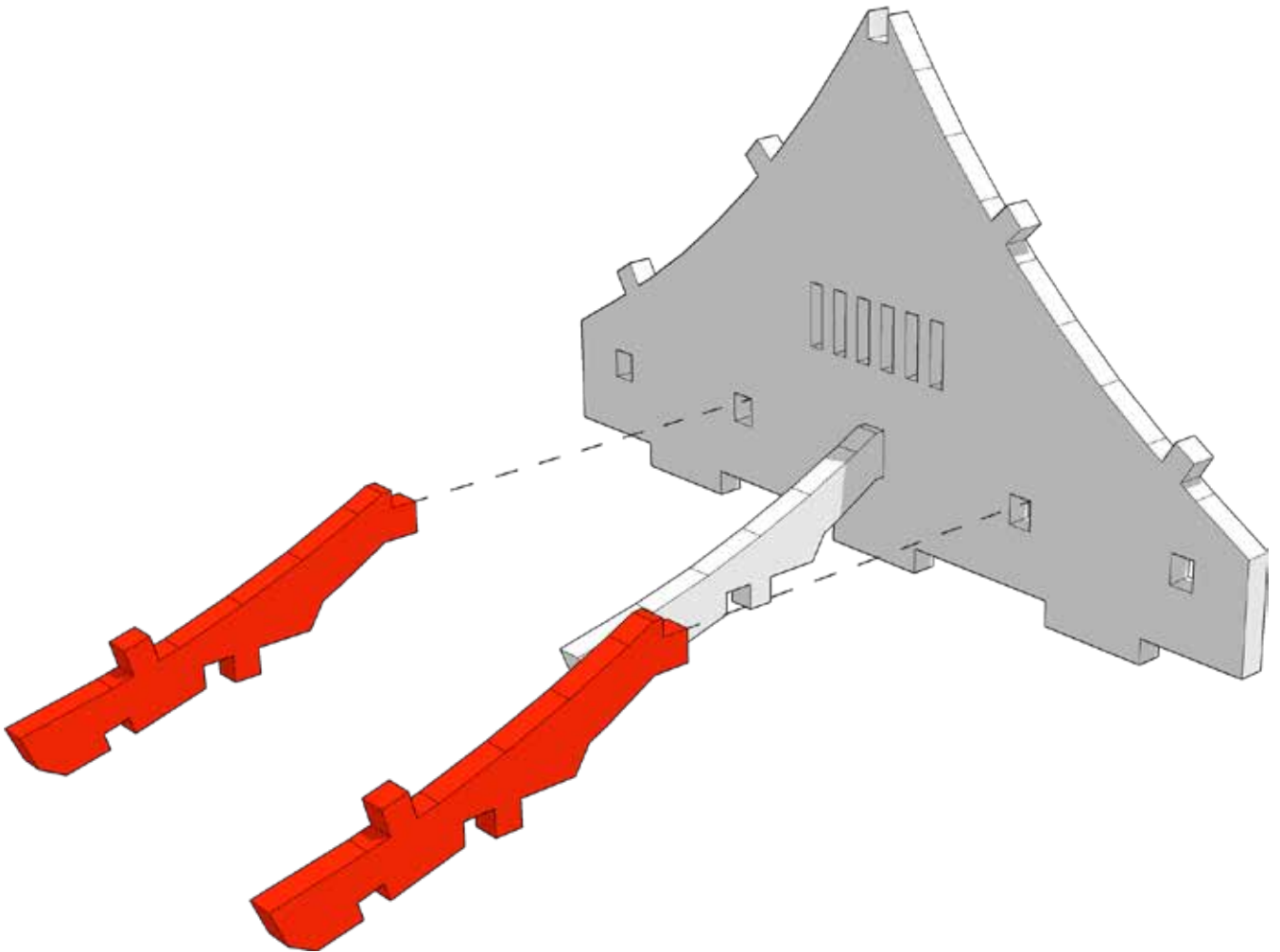



TABLETOP SCENICS

TTSCW-EES-115
Toshi:
Dojo

69

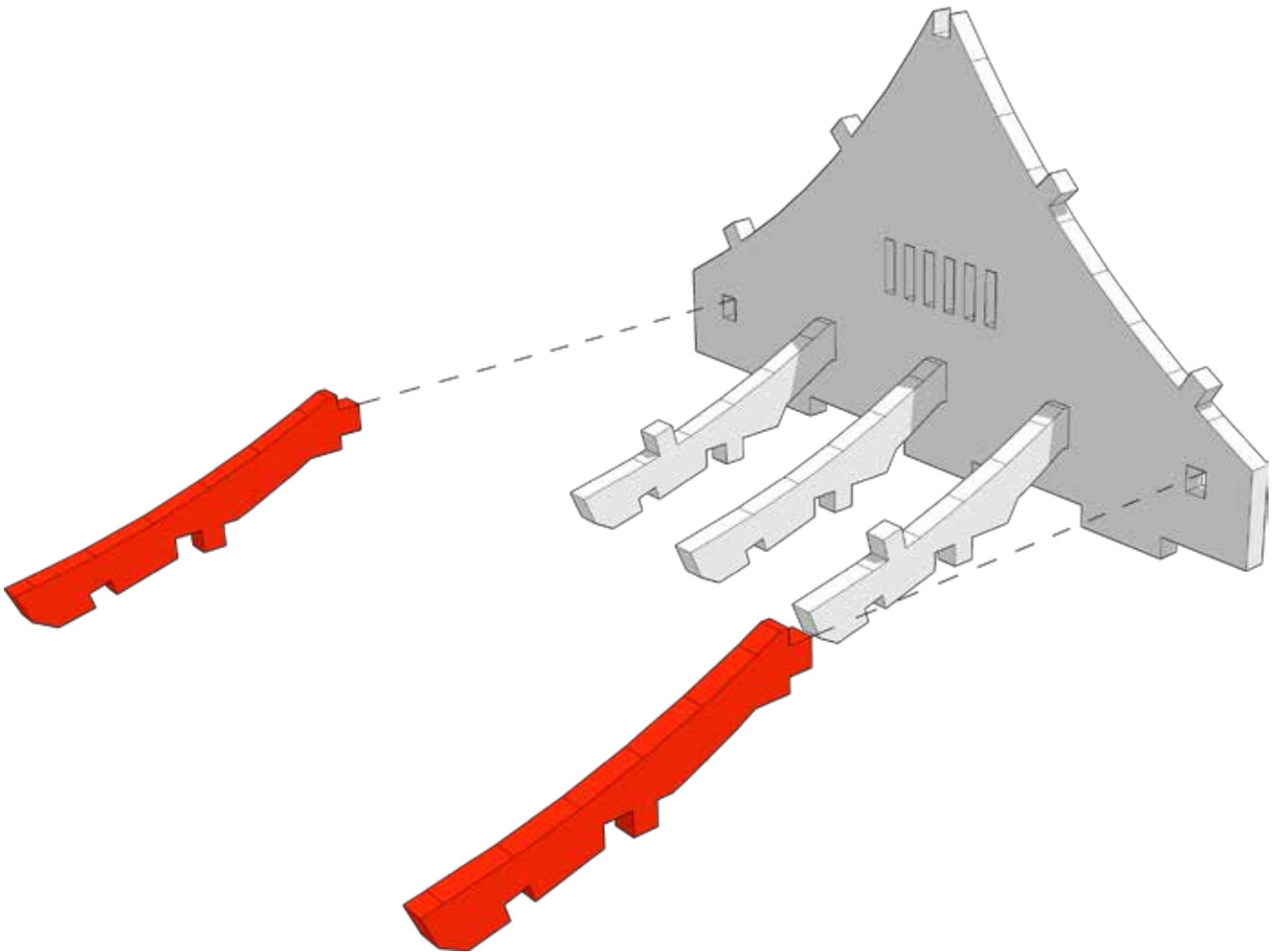



TABLETOP SCENICS

TTSCW-EES-115
Toshi:
Dojo

70

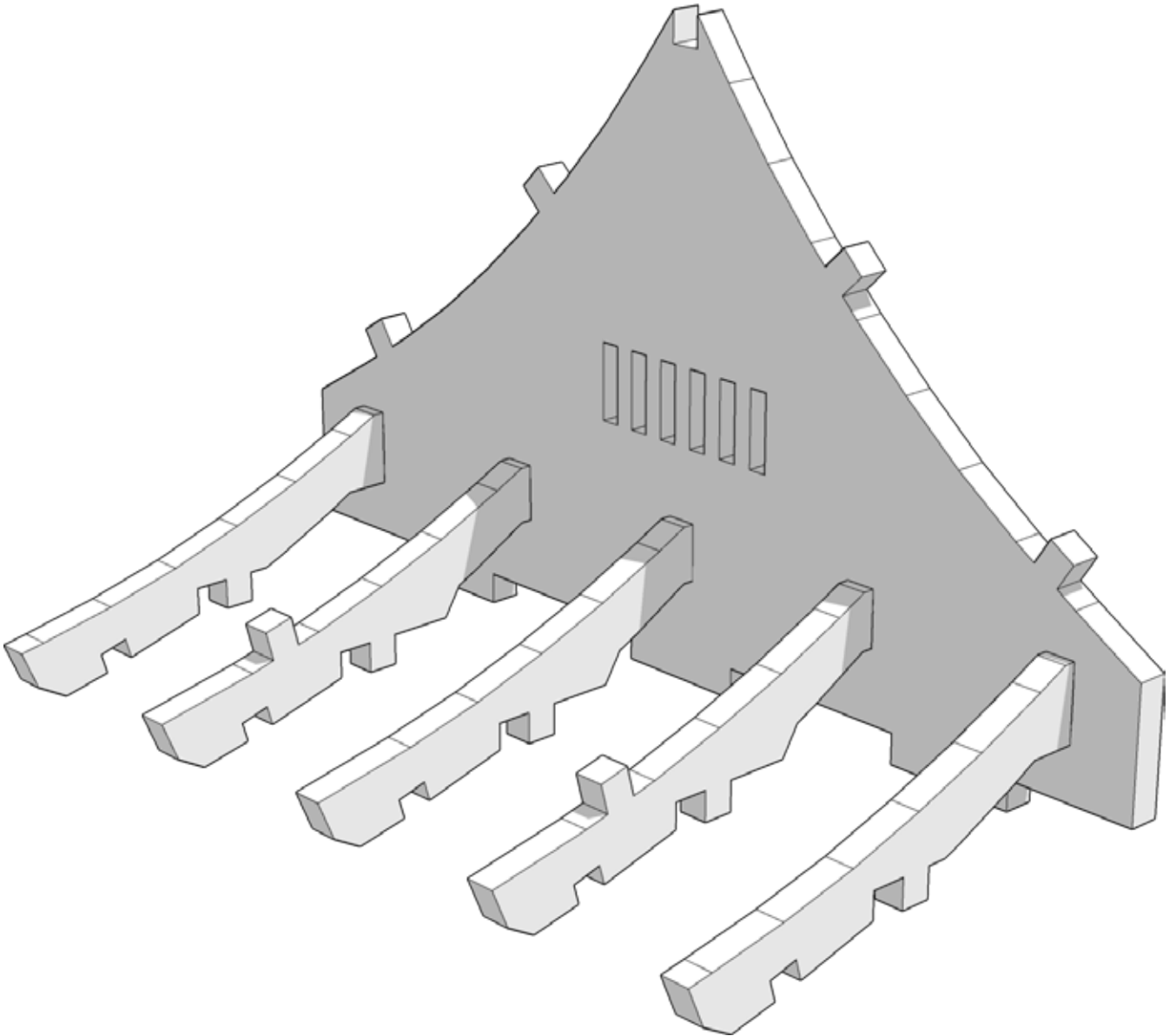

x2

 **TTCOMBAT**



TABLETOP SCENICS

TTSCW-EES-115
Toshi:
Dojo

71

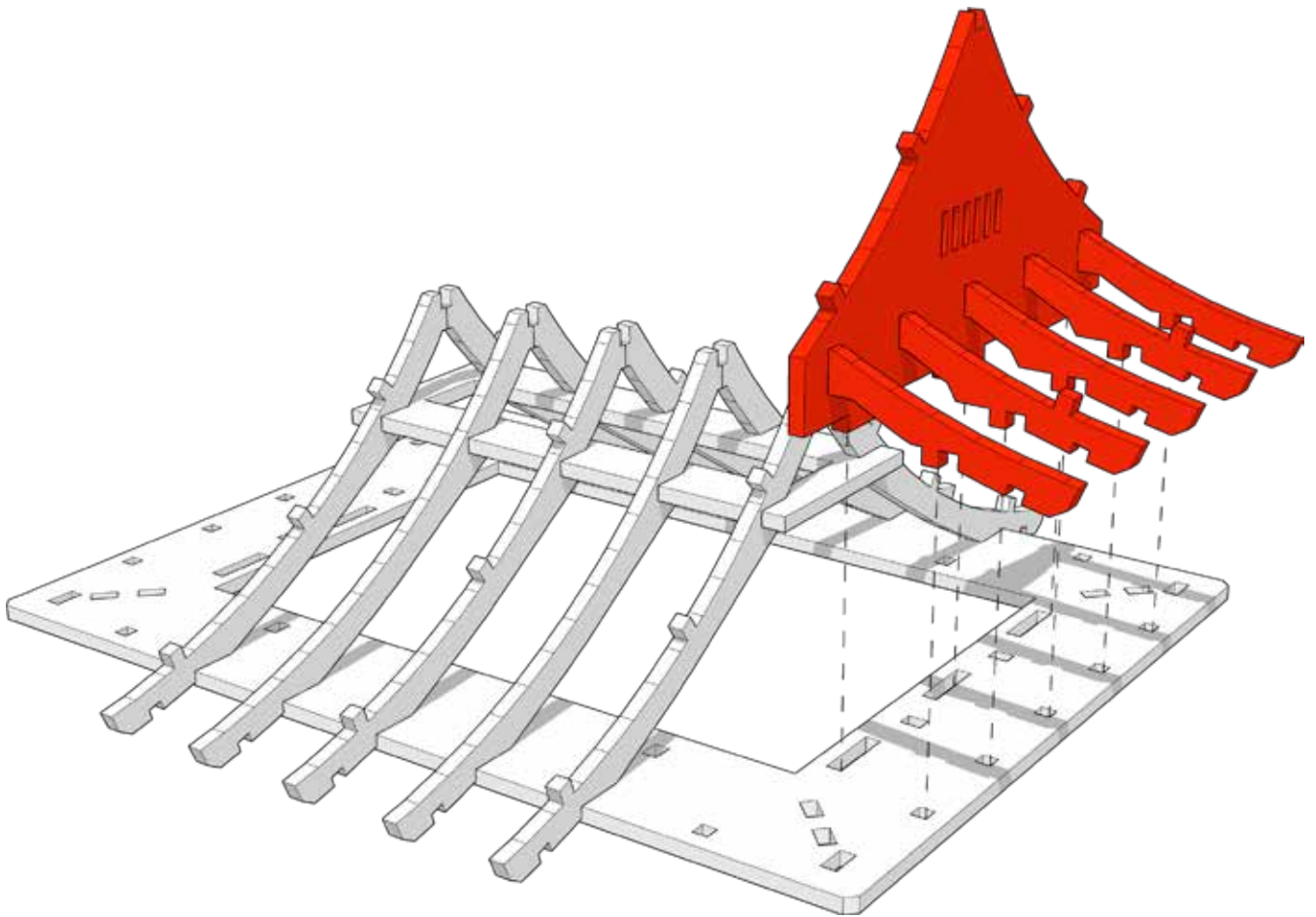



TABLETOP SCENICS

TTSCW-EES-115
Toshi:
Dojo

72

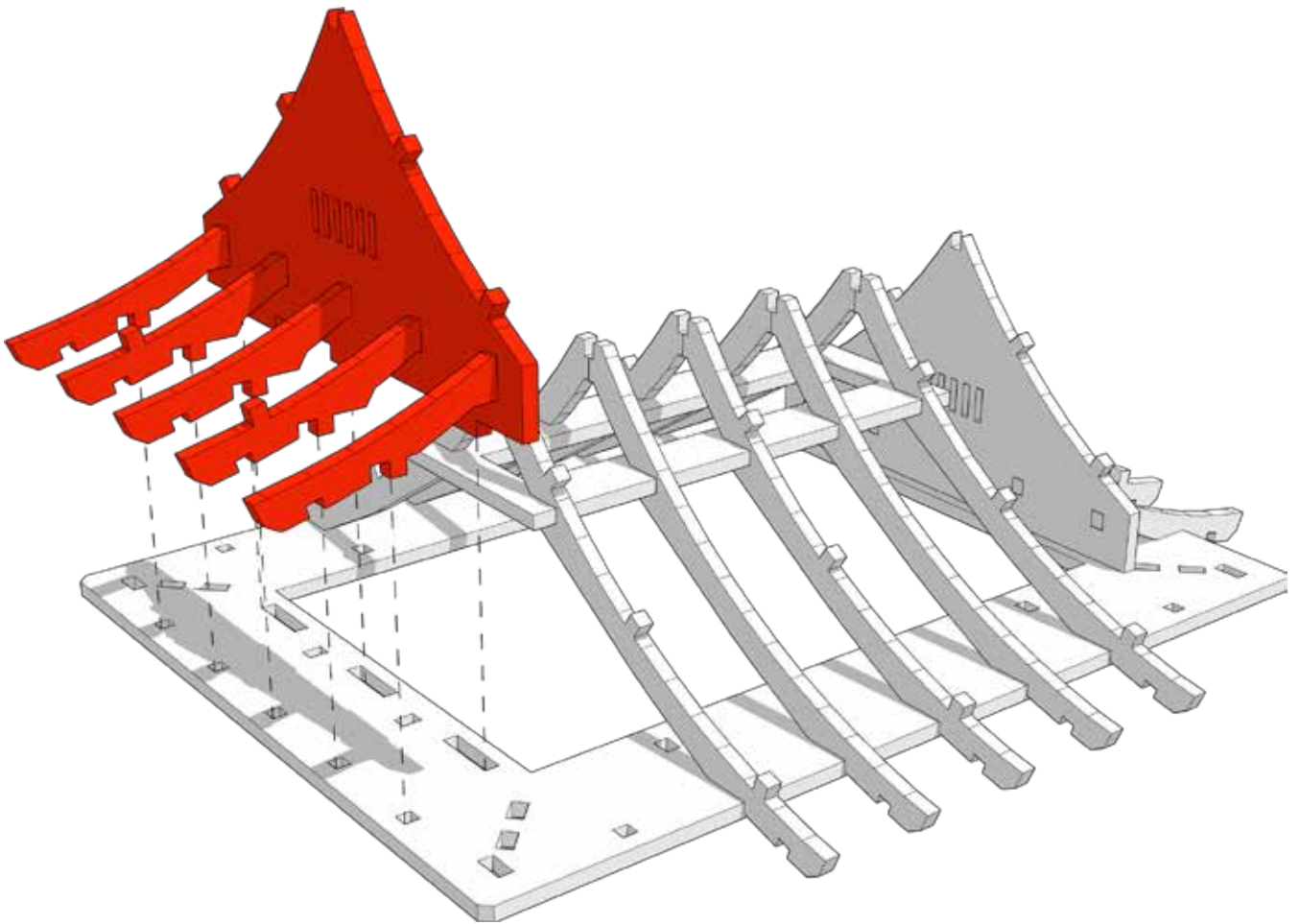



TABLETOP SCENICS

TTSCW-EES-115
Toshi:
Dojo

73

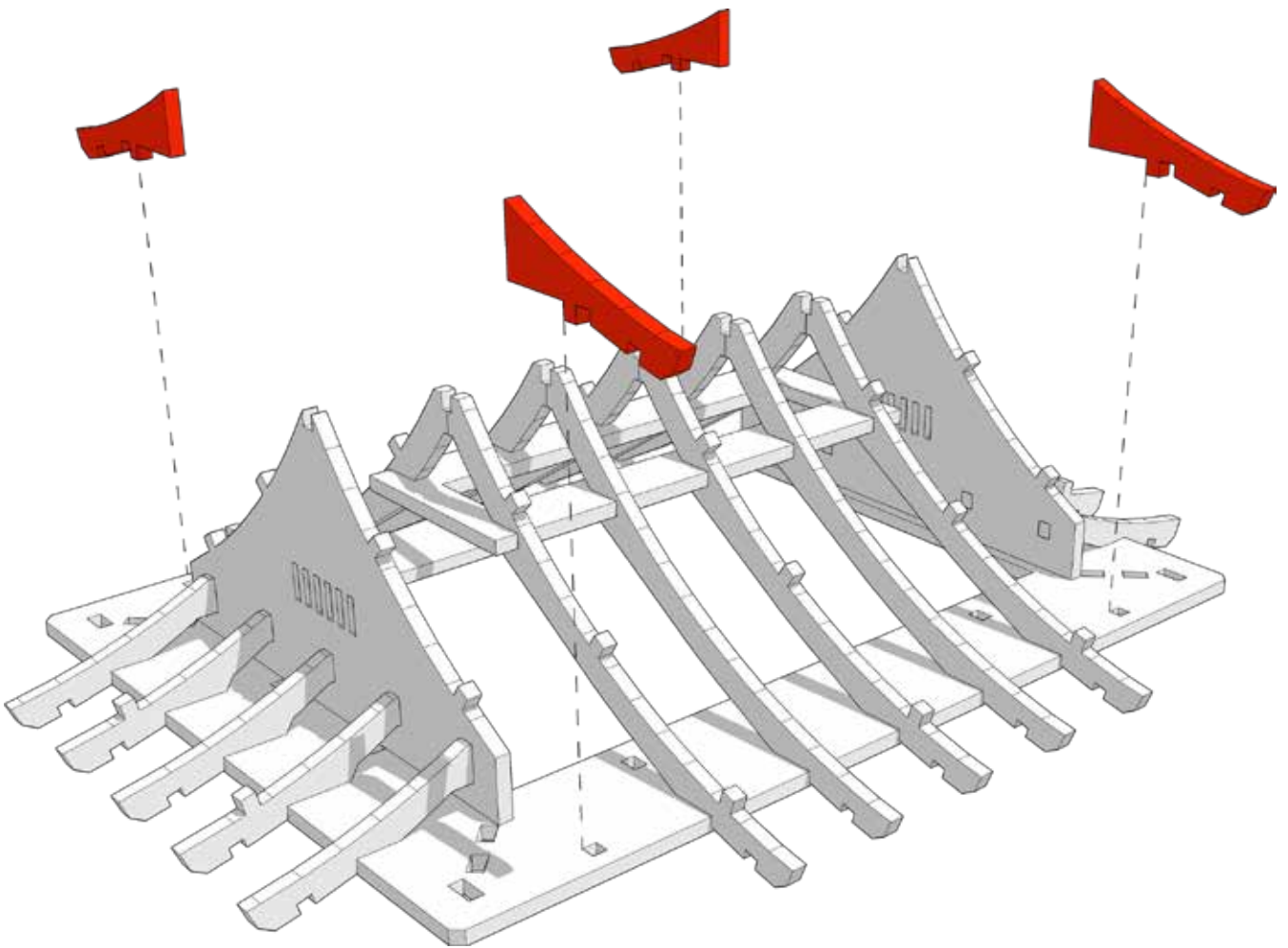



TABLETOP SCENICS

TTSCW-EES-115
Toshi:
Dojo

74

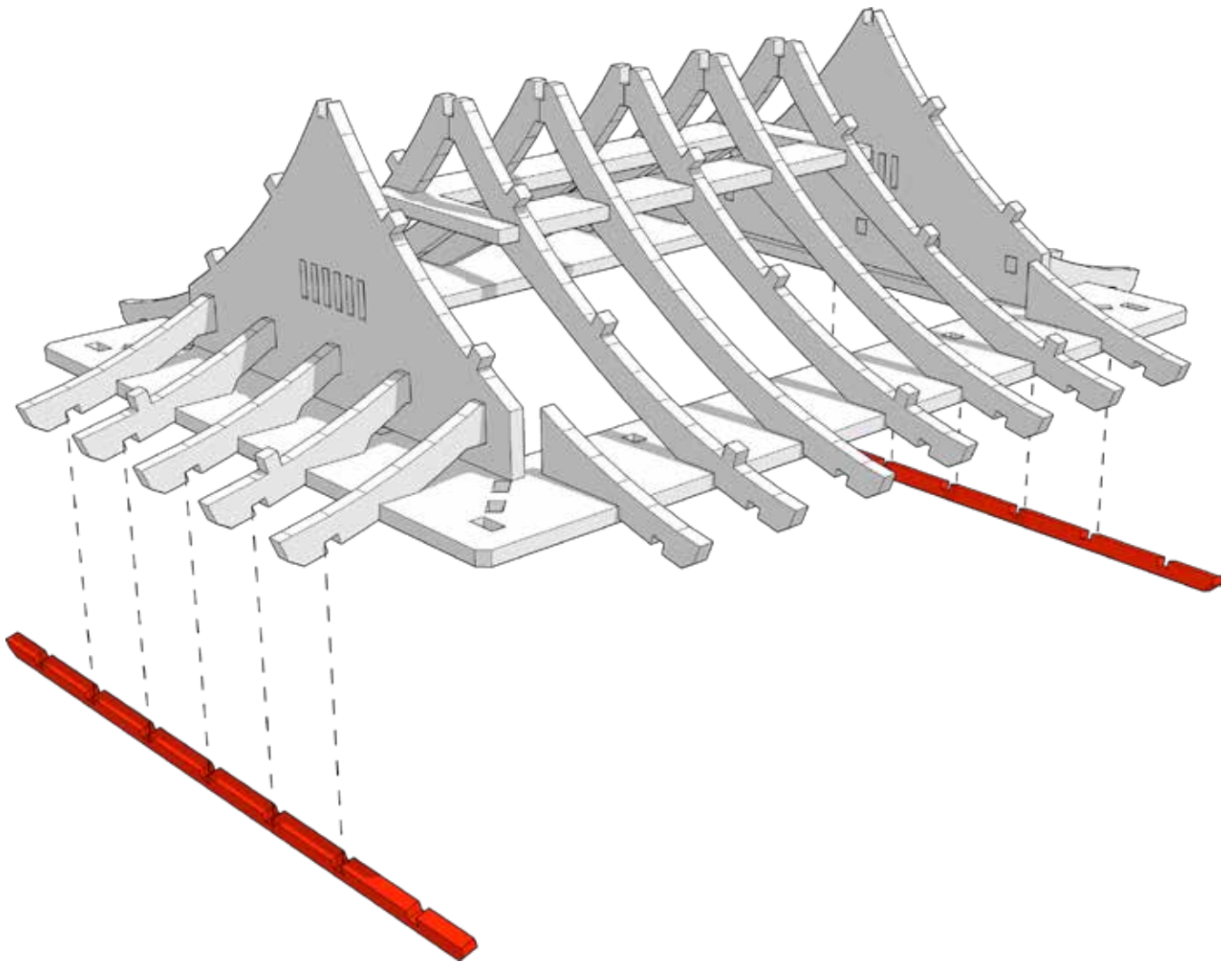

Highlighted parts are shorter in
length than similar parts





TABLETOP SCENICS

TTSCW-EES-115
Toshi:
Dojo

75

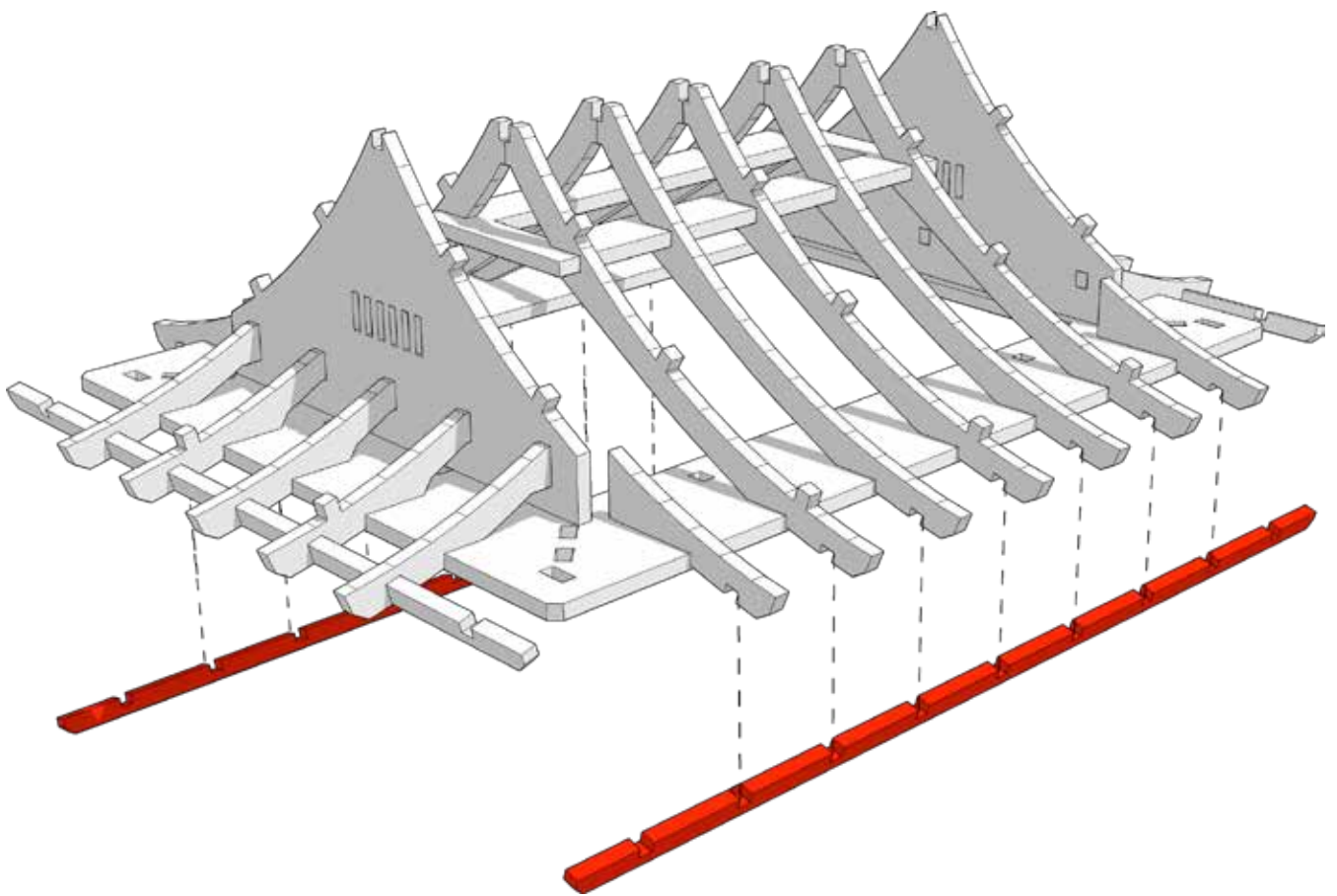



TABLETOP SCENICS

TTSCW-EES-115
Toshi:
Dojo

76

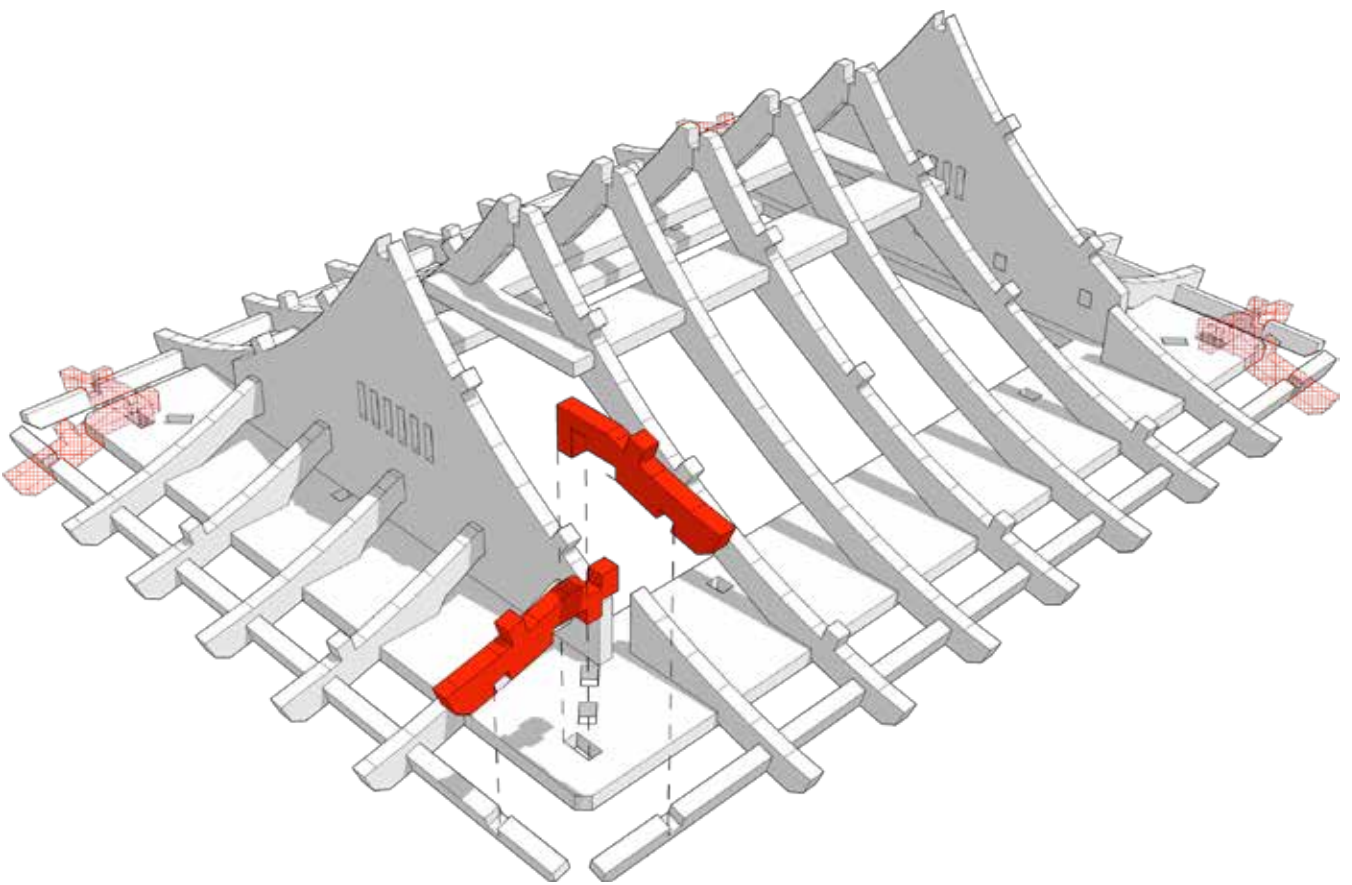



77

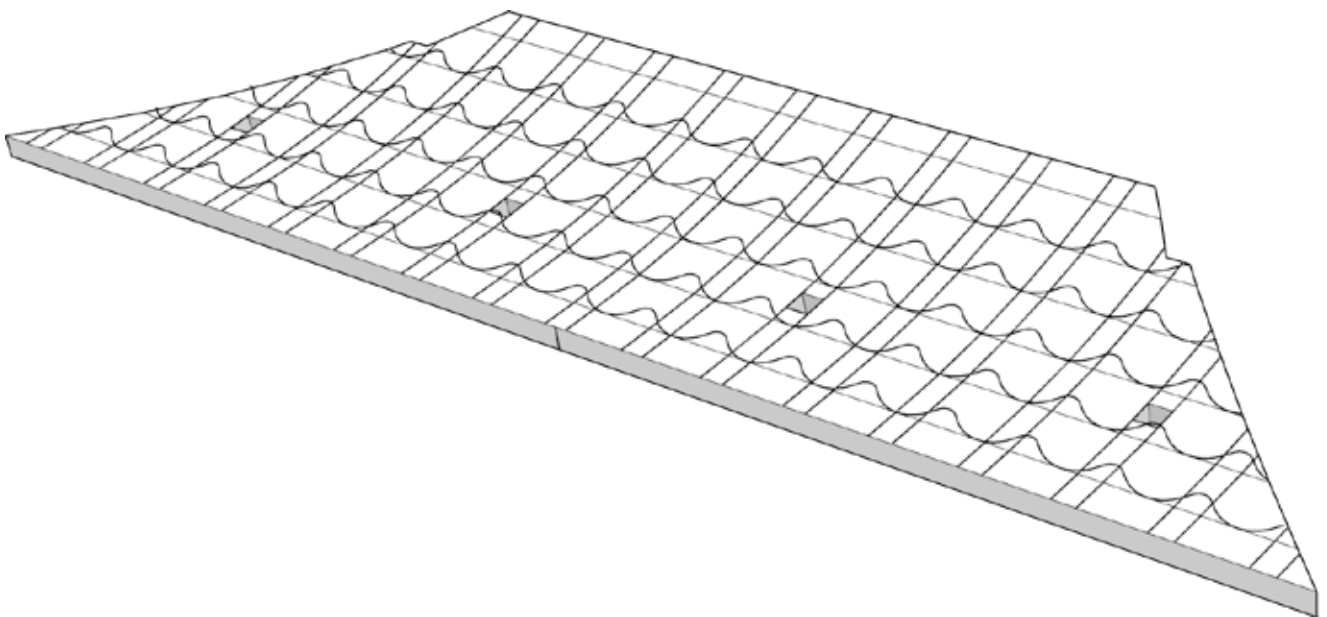

FRAGILE

Over bending will cause this to break

Do not bend freely



TABLETOP SCENICS

TTSCW-EES-115
Toshi:
Dojo

78

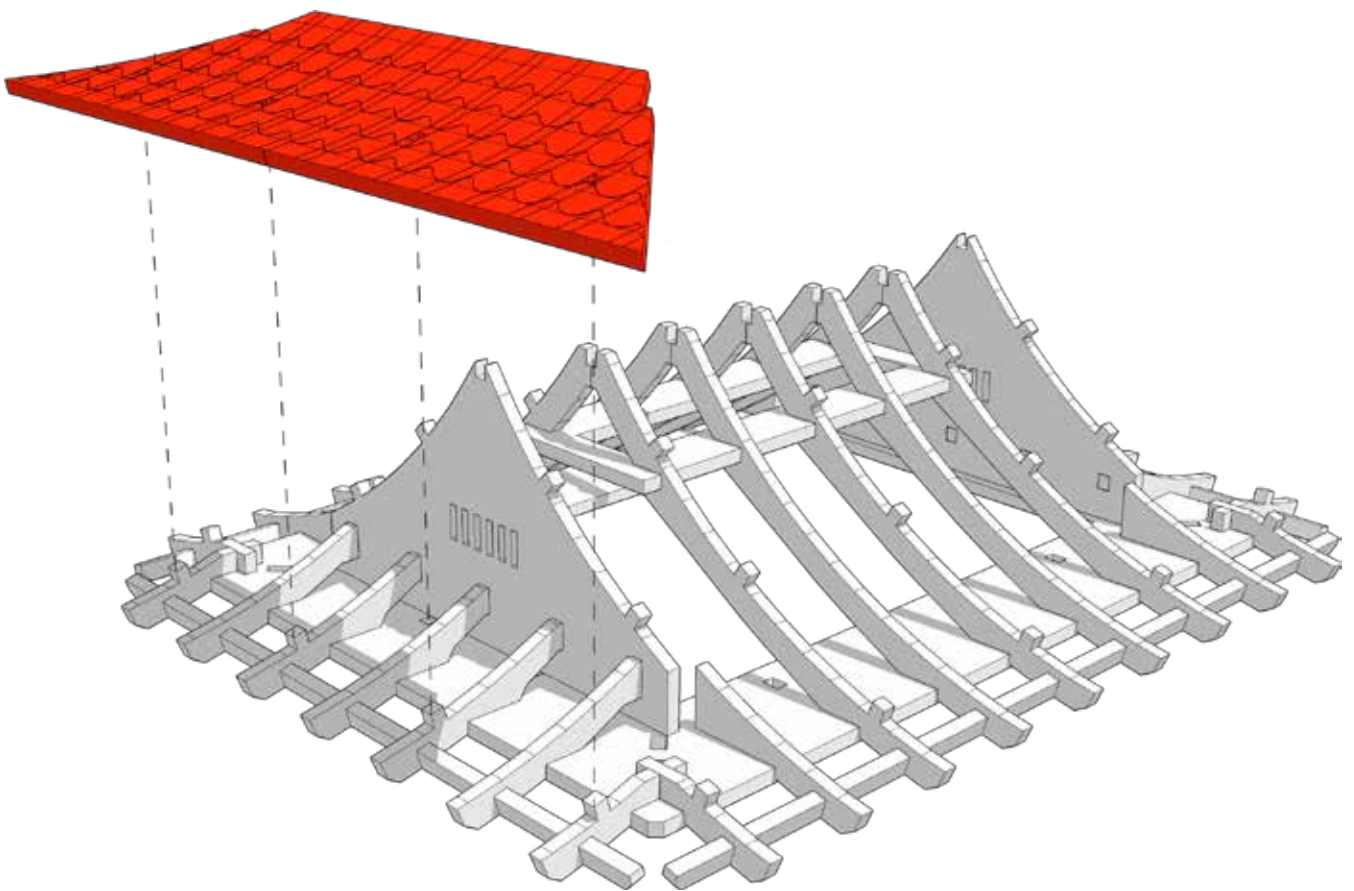

Align the tabs and push down onto the supports underneath to create curve shape.

Using superglue or a fast drying glue is recommended.



 **TTCOMBAT**



TABLETOP SCENICS

TTSCW-EES-115
Toshi:
Dojo

79

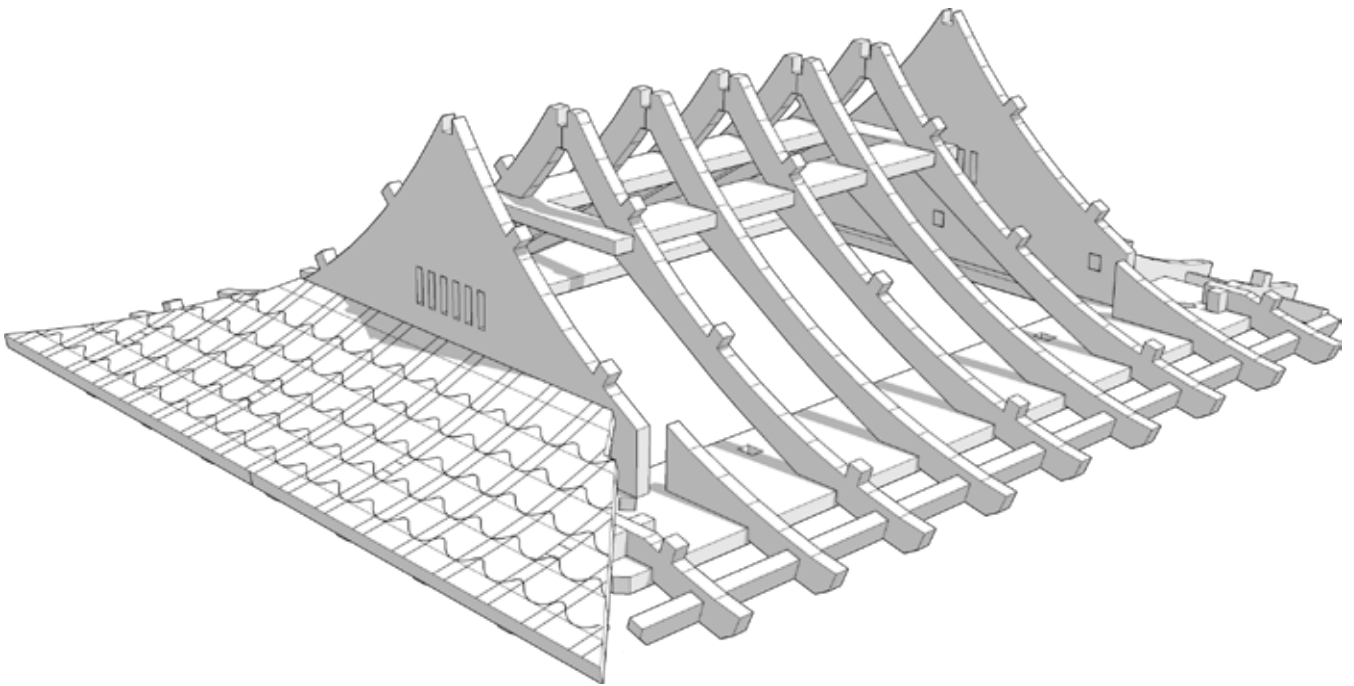



TABLETOP SCENICS

TTSCW-EES-115
Toshi:
Dojo

80

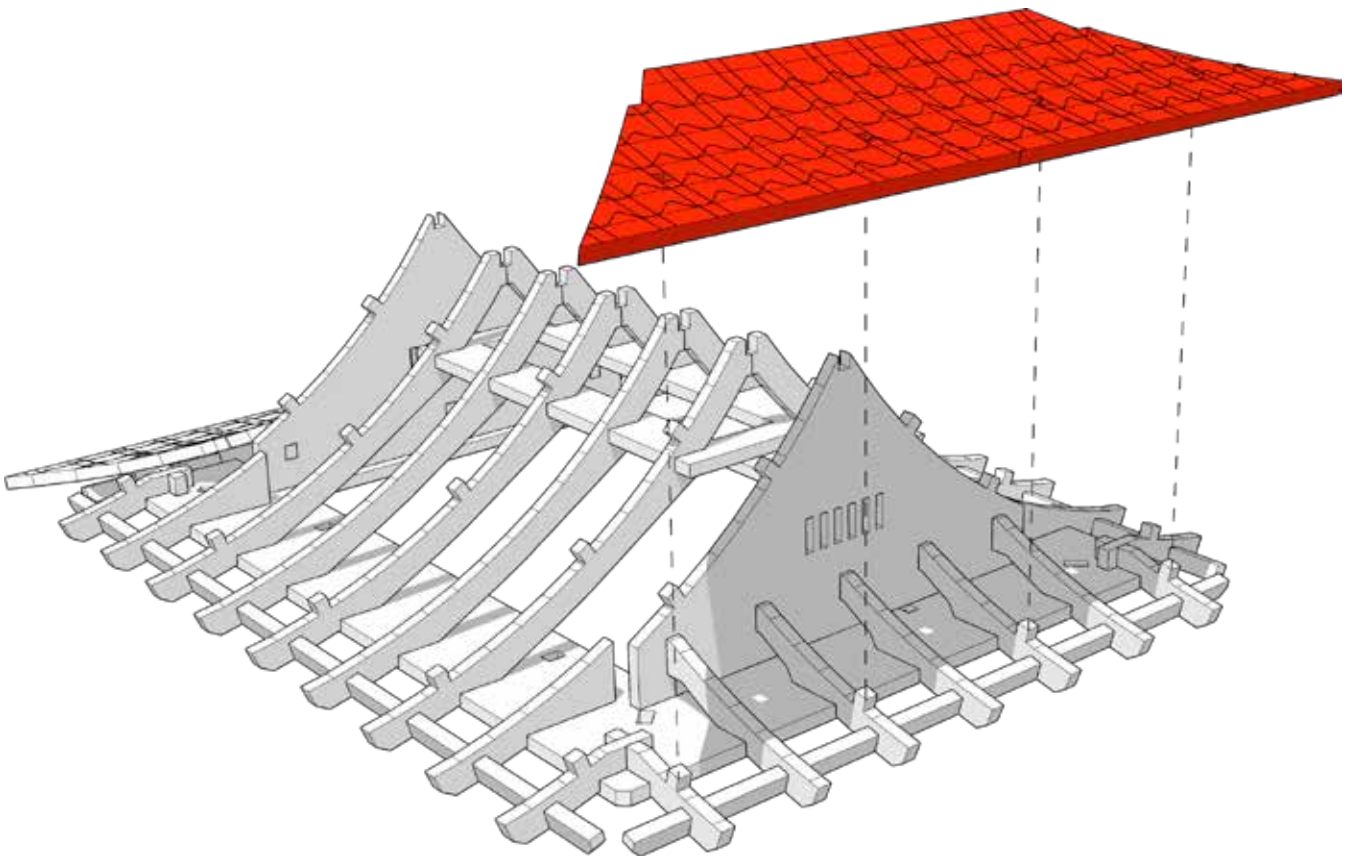

Align the tabs and push down onto the supports underneath to create curve shape.

Using superglue or a fast drying glue is recommended.



 **TTCOMBAT**



TABLETOP SCENICS

TTSCW-EES-115
Toshi:
Dojo

81

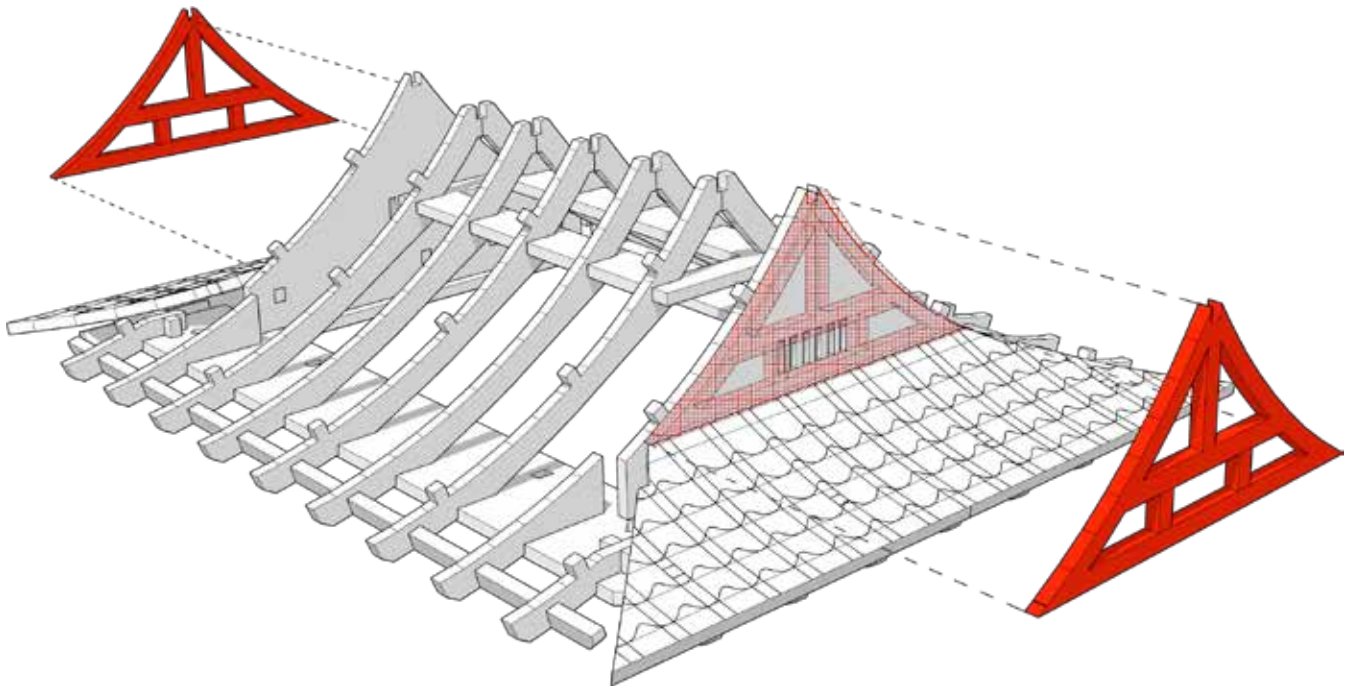



TABLETOP SCENICS

TTSCW-EES-115
Toshi:
Dojo

82

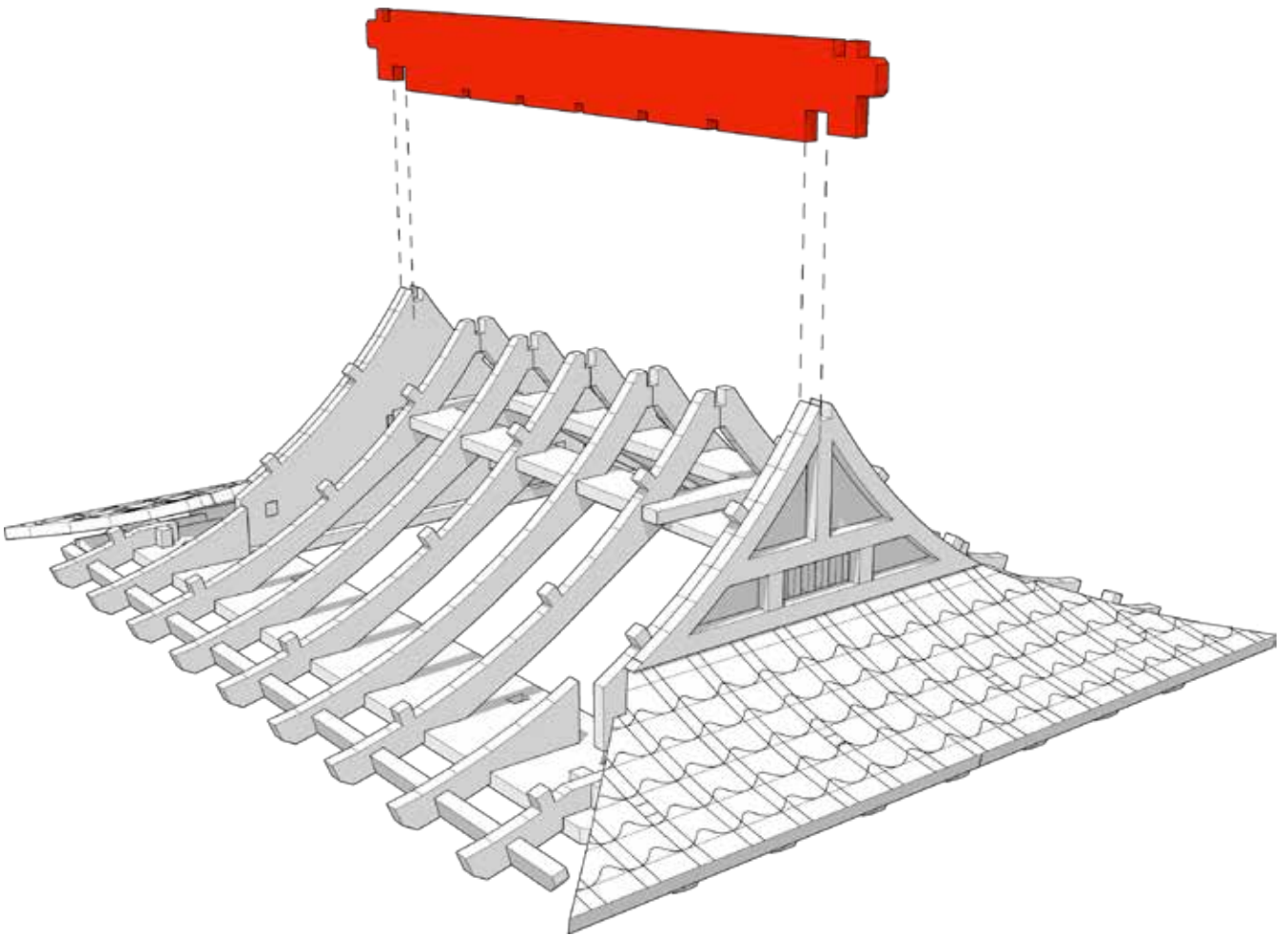



83

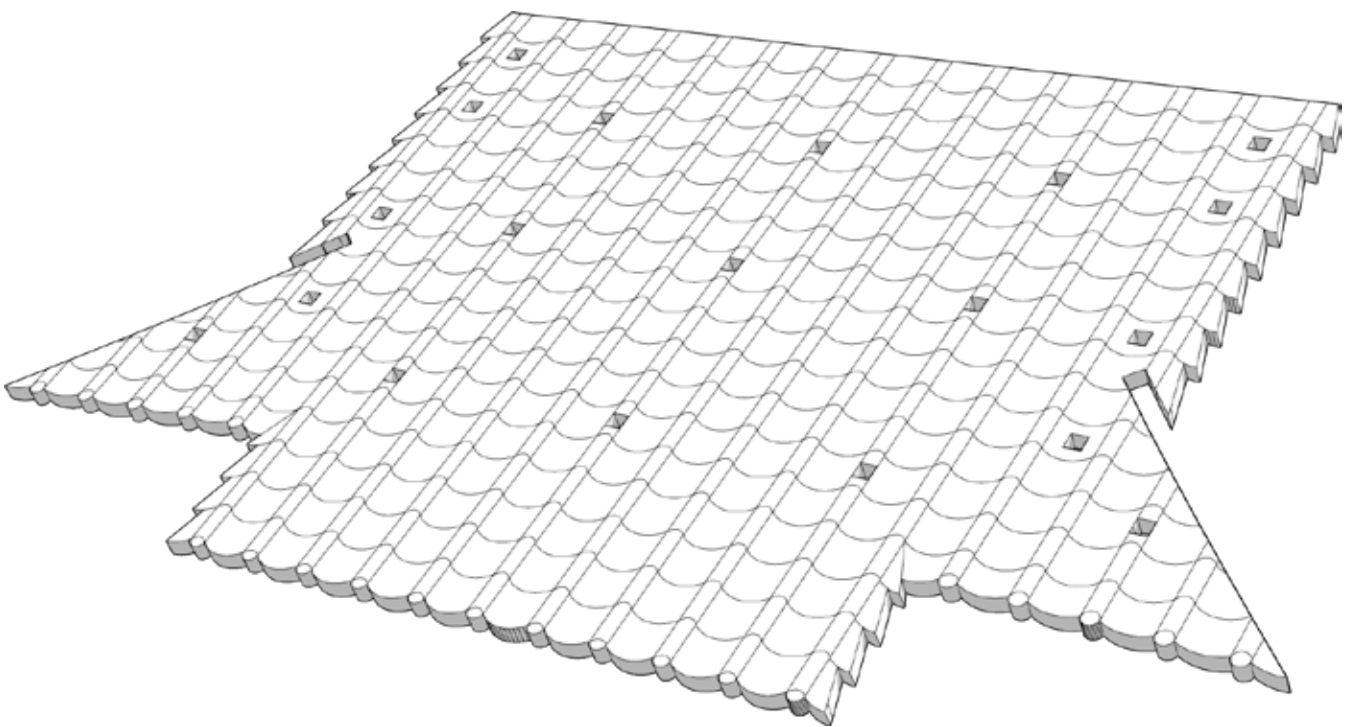

FRAGILE

Over bending will cause this to break
Do not bend freely



TABLETOP SCENICS

TTSCW-EES-115
Toshi:
Dojo

84

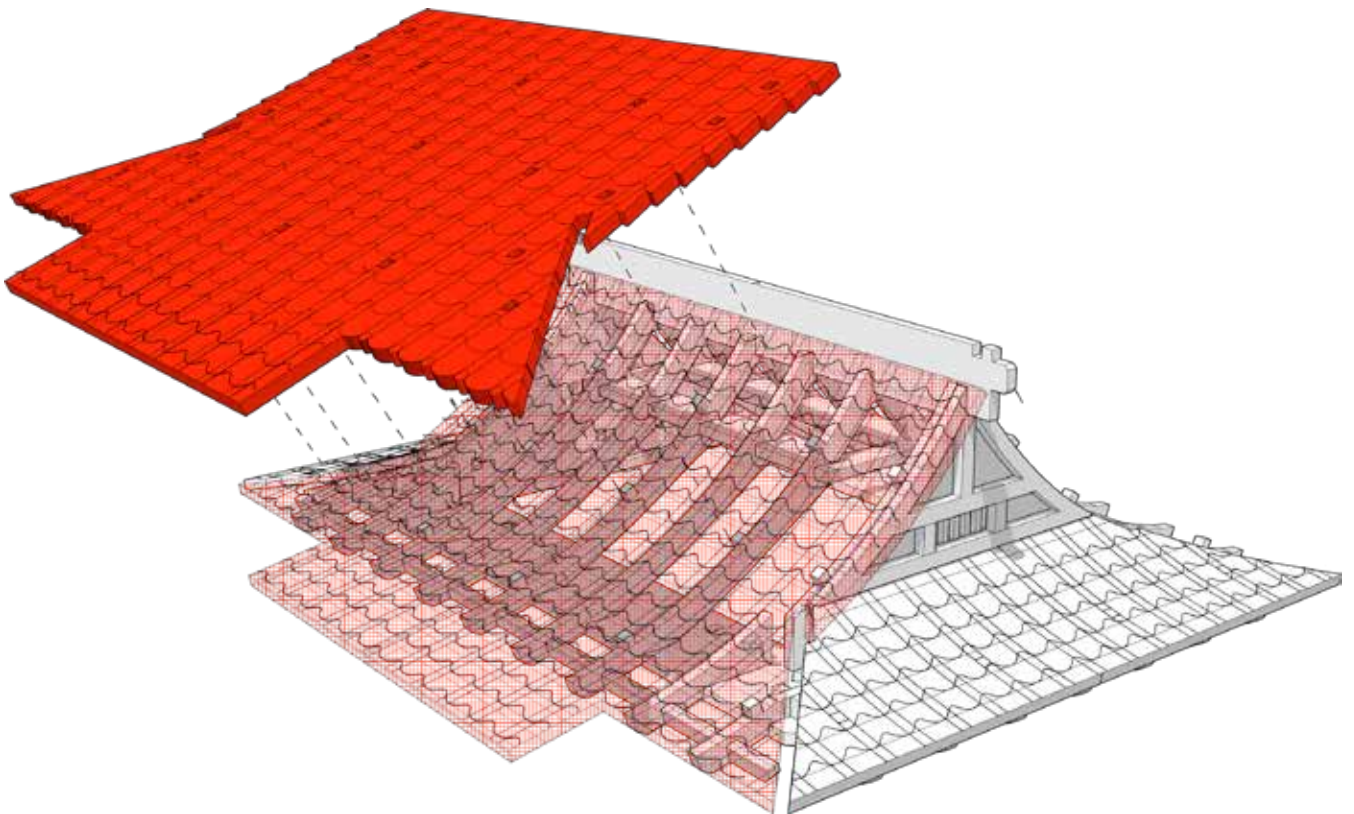

Align the tabs from the top of the roof and push down to the bottom and it should slot into place. Hold the part onto the supports below to create the curved shape until dry.

Using superglue or a fast drying glue is recommended.



 **TTCOMBAT**



TABLETOP SCENICS

TTSCW-EES-115
Toshi:
Dojo

85

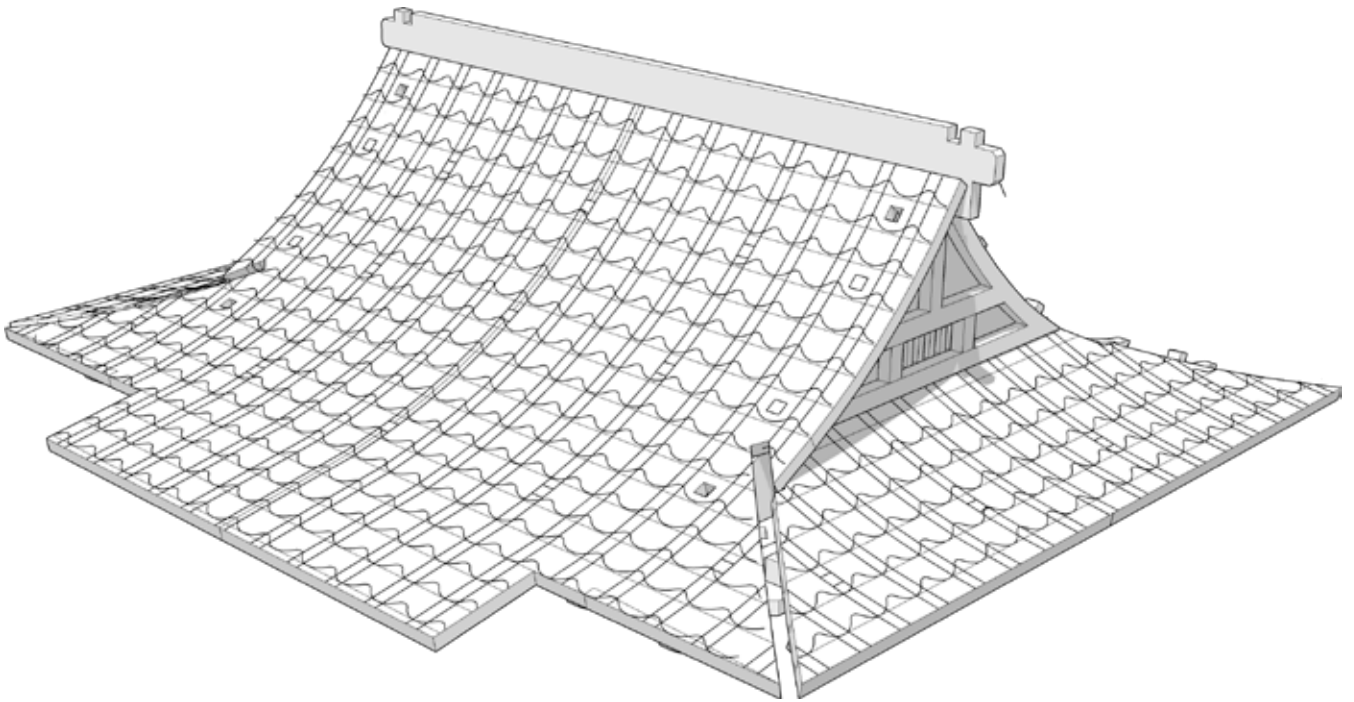



86

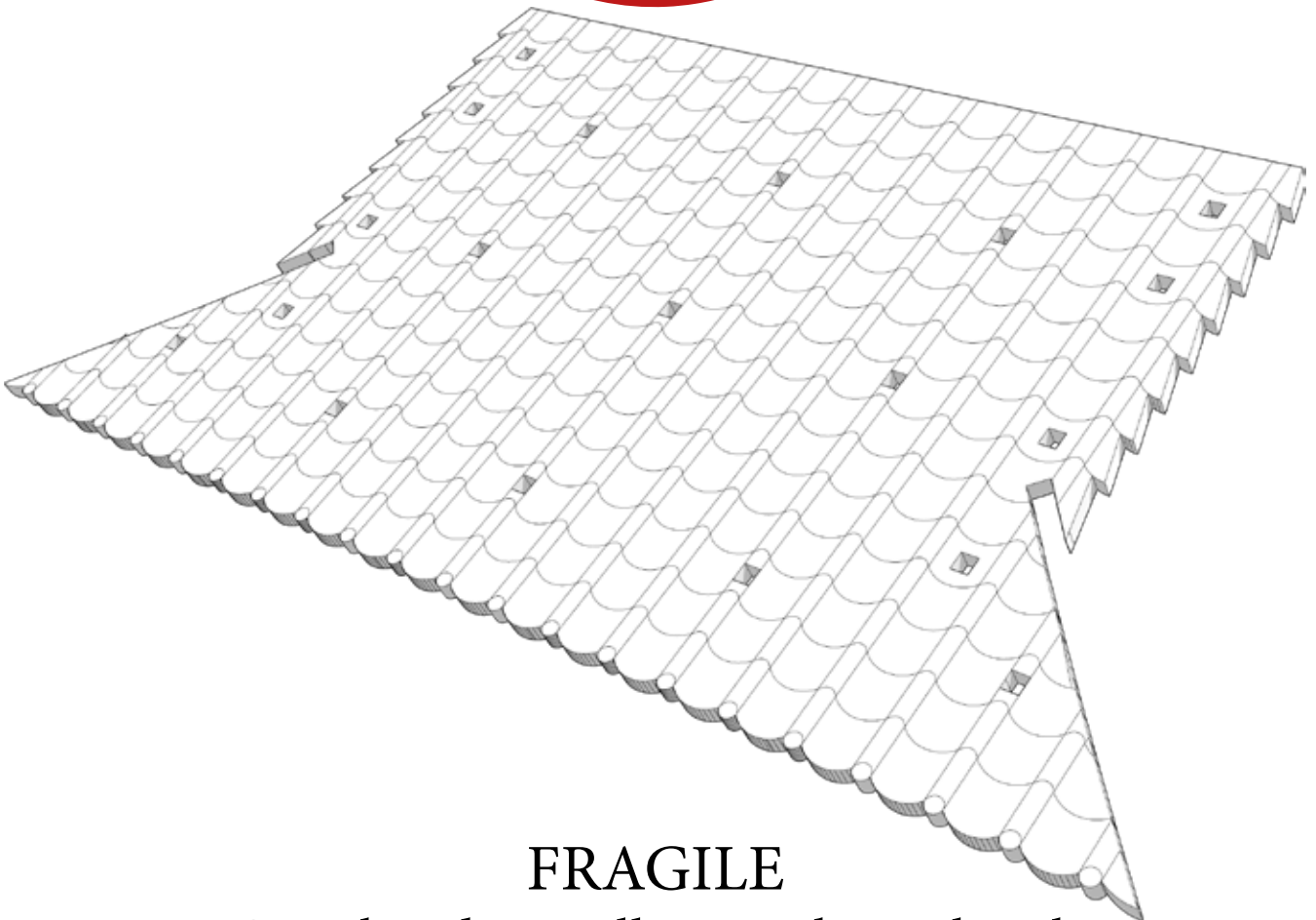

FRAGILE

Over bending will cause this to break

Do not bend freely



TABLETOP SCENICS

TTSCW-EES-115
Toshi:
Dojo

87

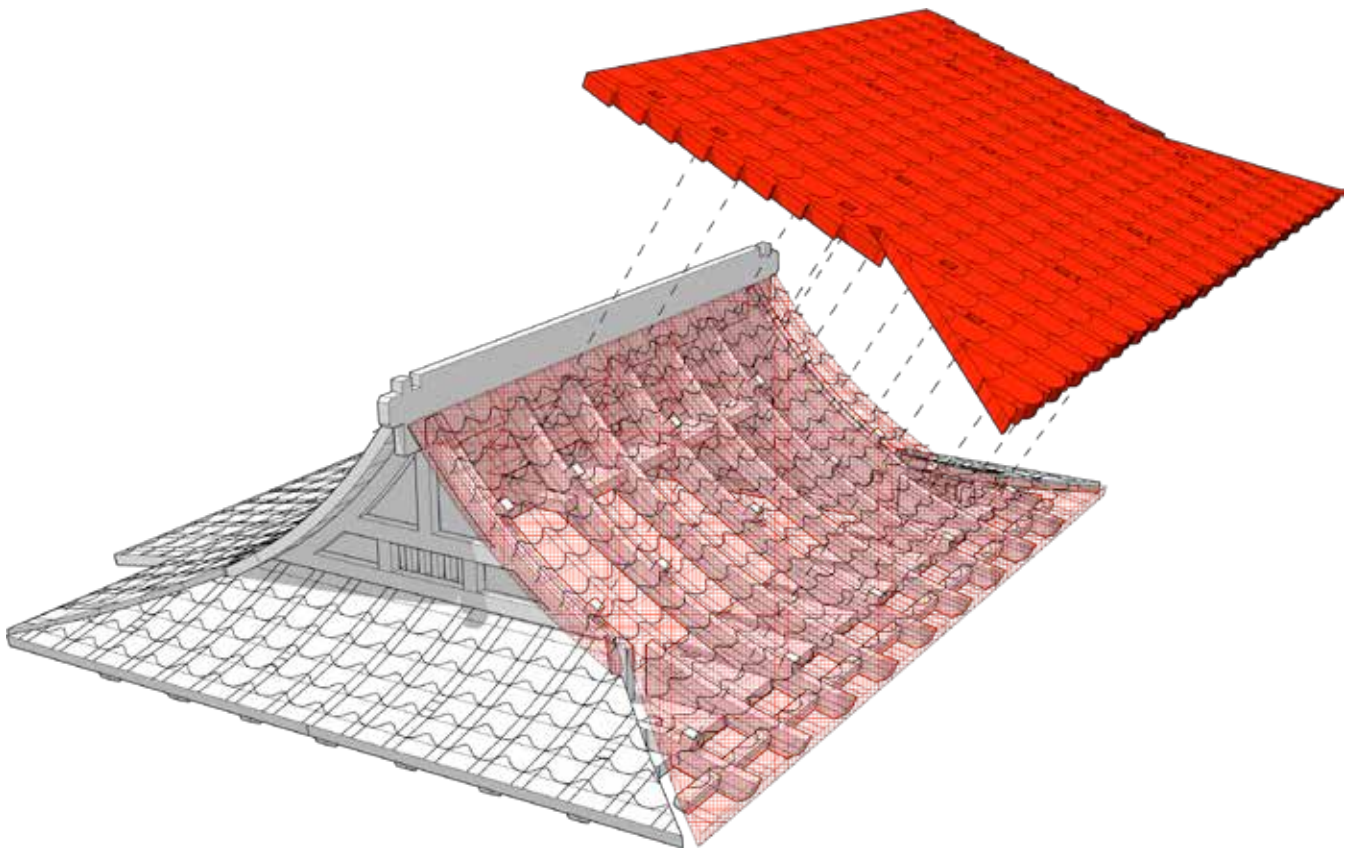

Align the tabs from the top of the roof and push down to the bottom and it should slot into place. Hold the part onto the supports below to create the curved shape until dry.

Using superglue or a fast drying glue is recommended.



 **TTCOMBAT**



TABLETOP SCENICS

TTSCW-EES-115
Toshi:
Dojo

88

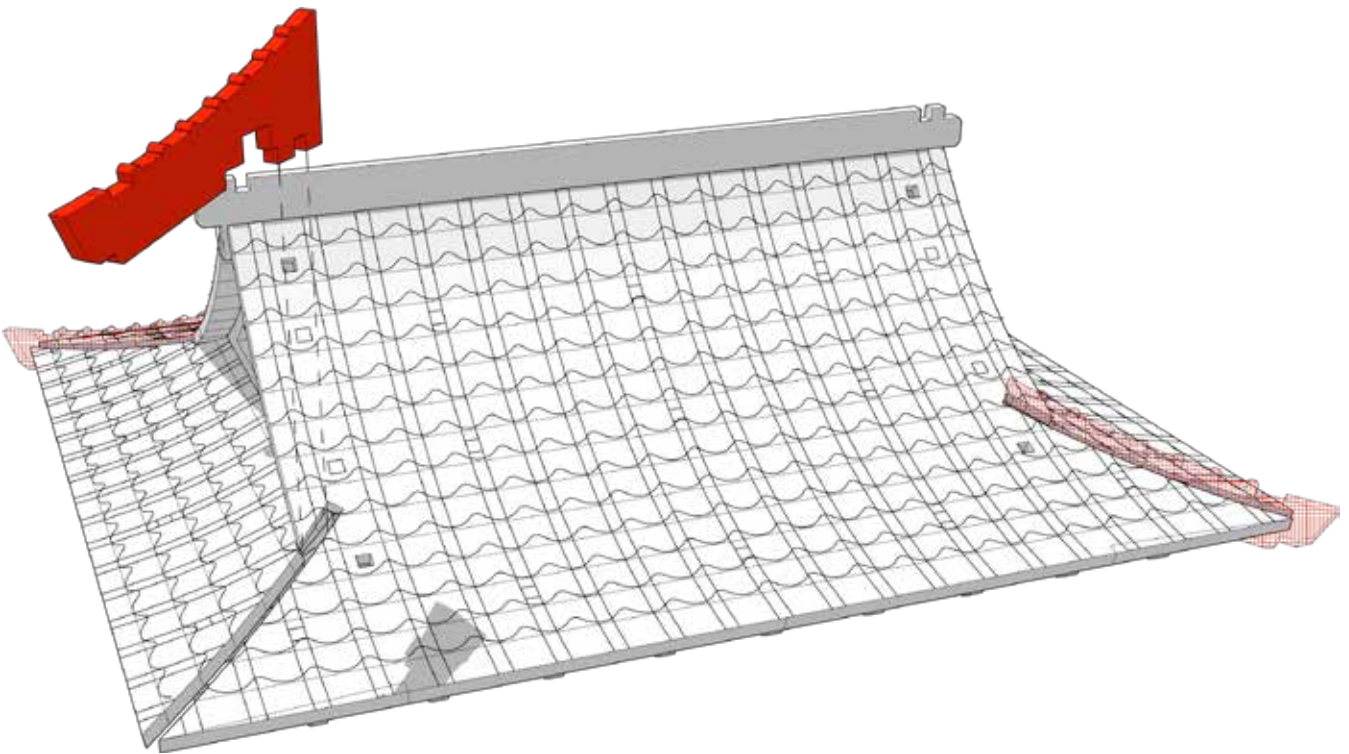

Highlighted part is a tight fit but can be pushed into place. Focus on aligning the tabs and gently rock into position between the two roof panels



 **TTCOMBAT**



TABLETOP SCENICS

TTSCW-EES-115
Toshi:
Dojo

89

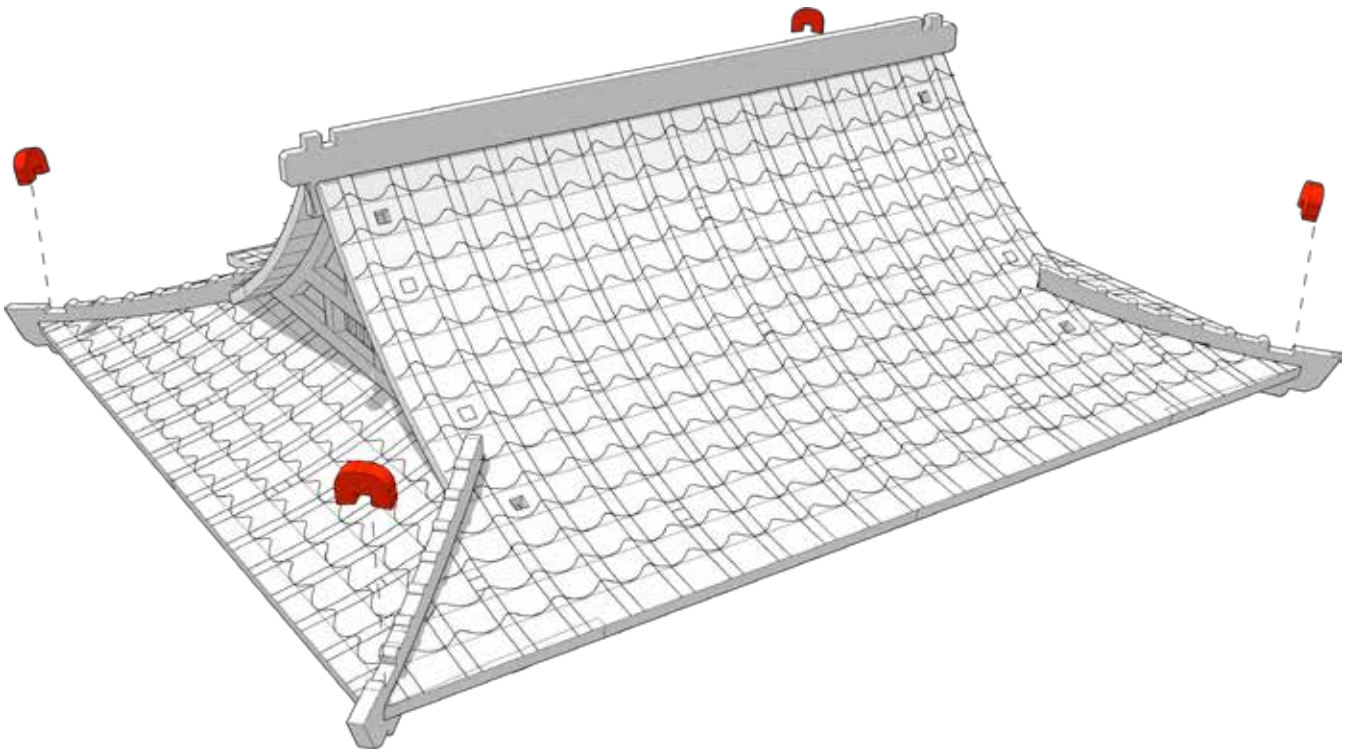



TABLETOP SCENICS

TTSCW-EES-115
Toshi:
Dojo

90

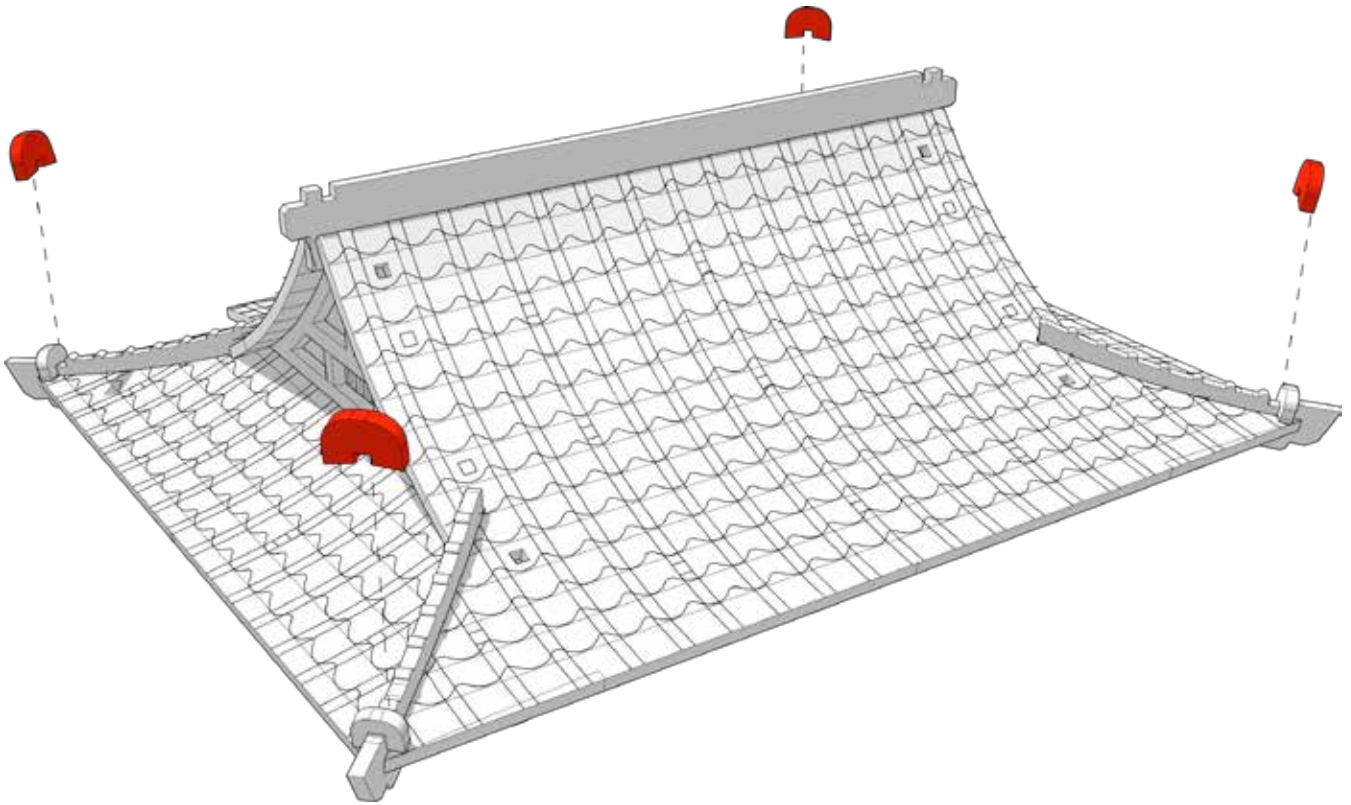



TABLETOP SCENICS

TTSCW-EES-115
Toshi:
Dojo

91

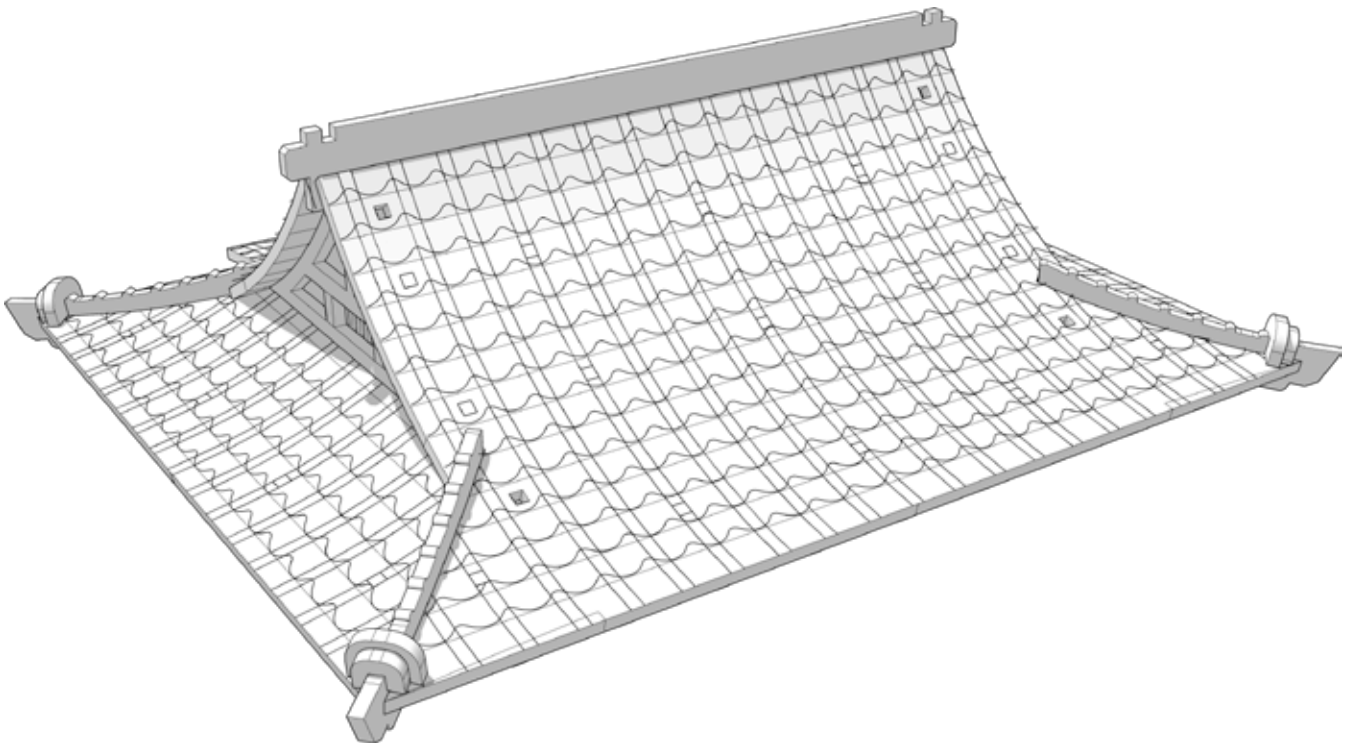



TABLETOP SCENICS

TTSCW-EES-115
Toshi:
Dojo

92

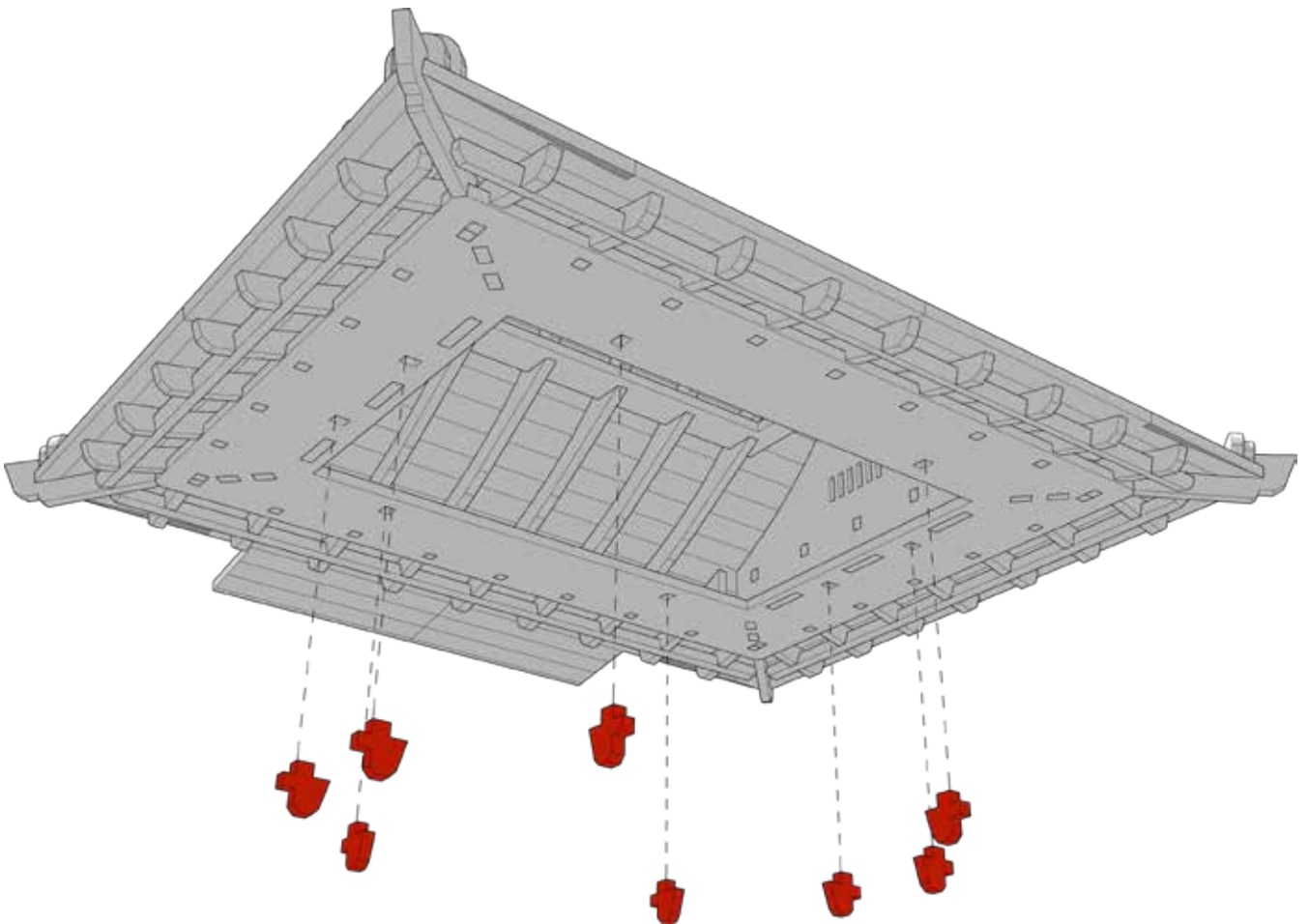

Position is the same for all parts



 TTCOMBAT



TABLETOP SCENICS

TTSCW-EES-115
Toshi:
Dojo

93

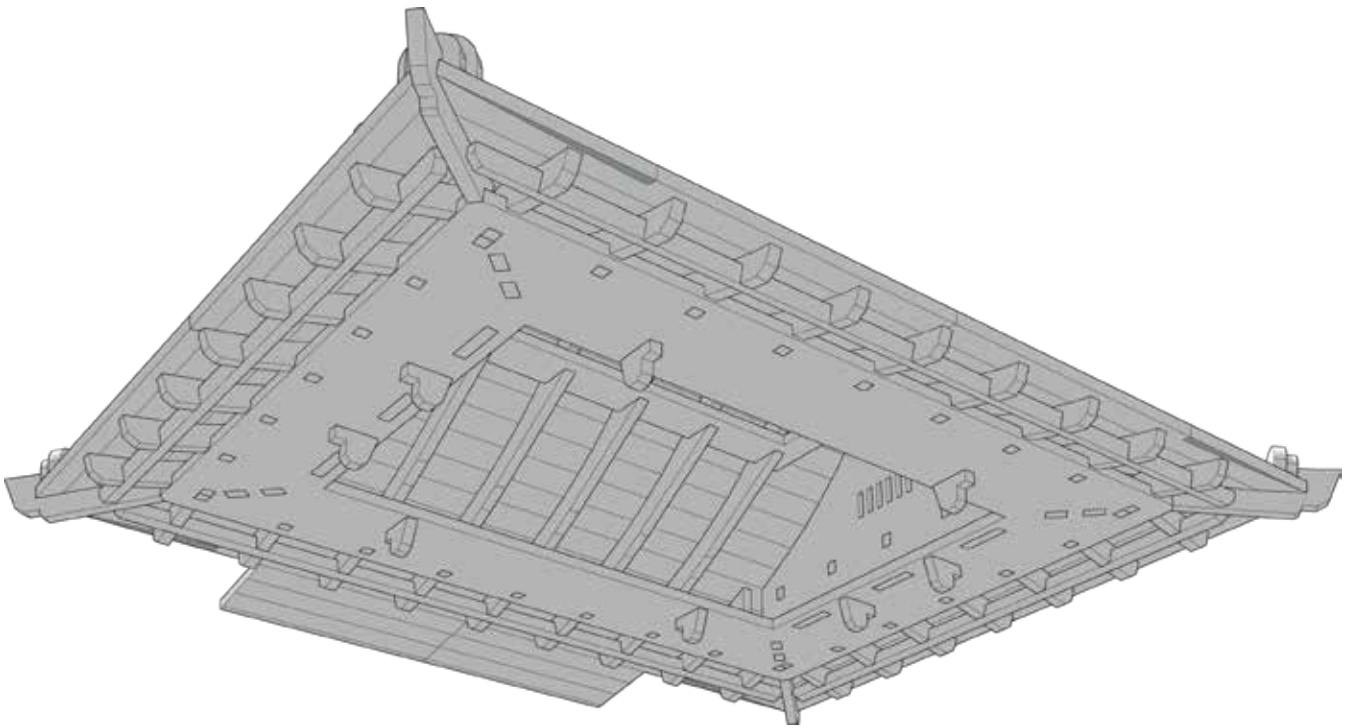



TABLETOP SCENICS

TTSCW-EES-115
Toshi:
Dojo

94

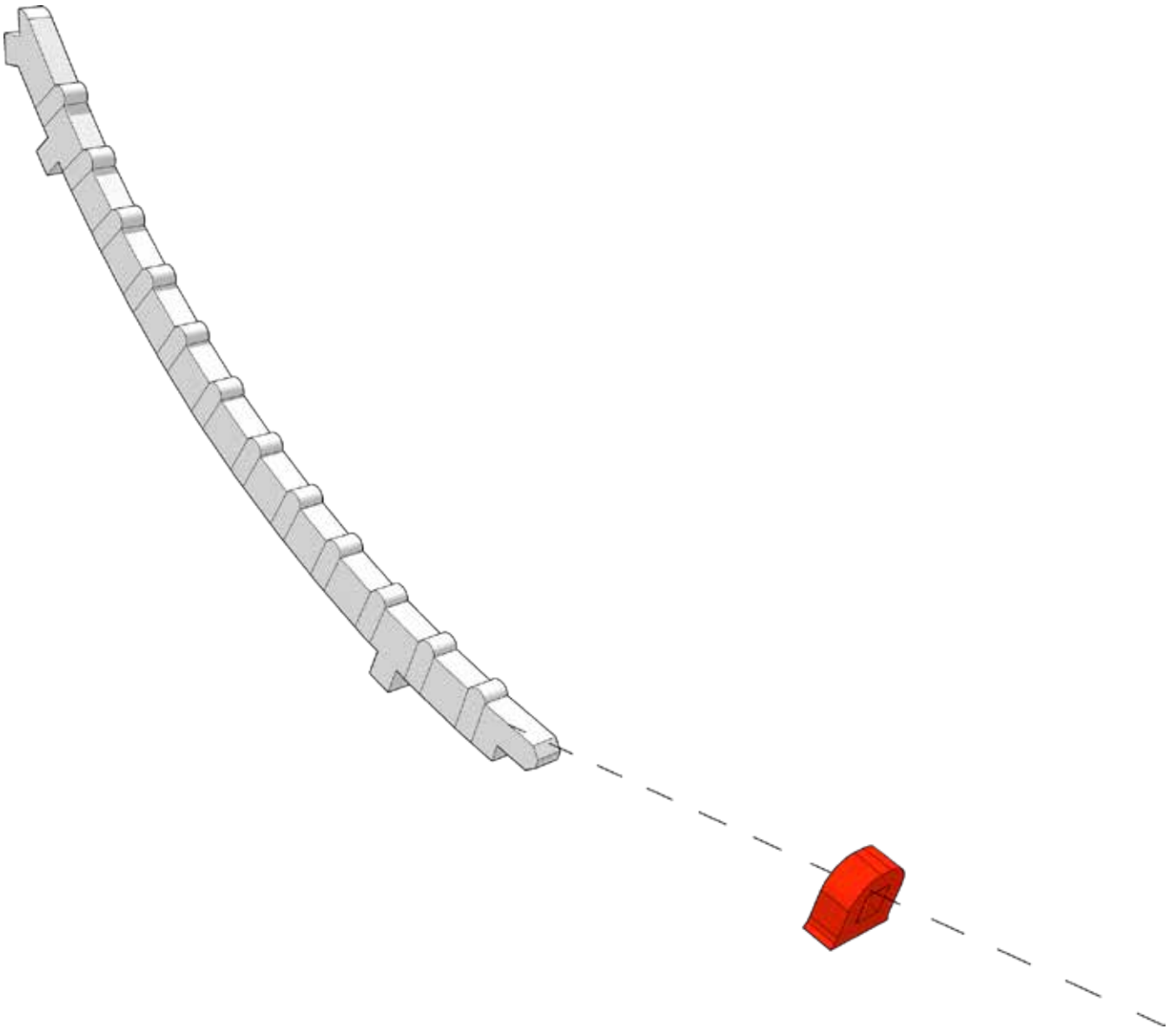



TABLETOP SCENICS

TTSCW-EES-115
Toshi:
Dojo

95

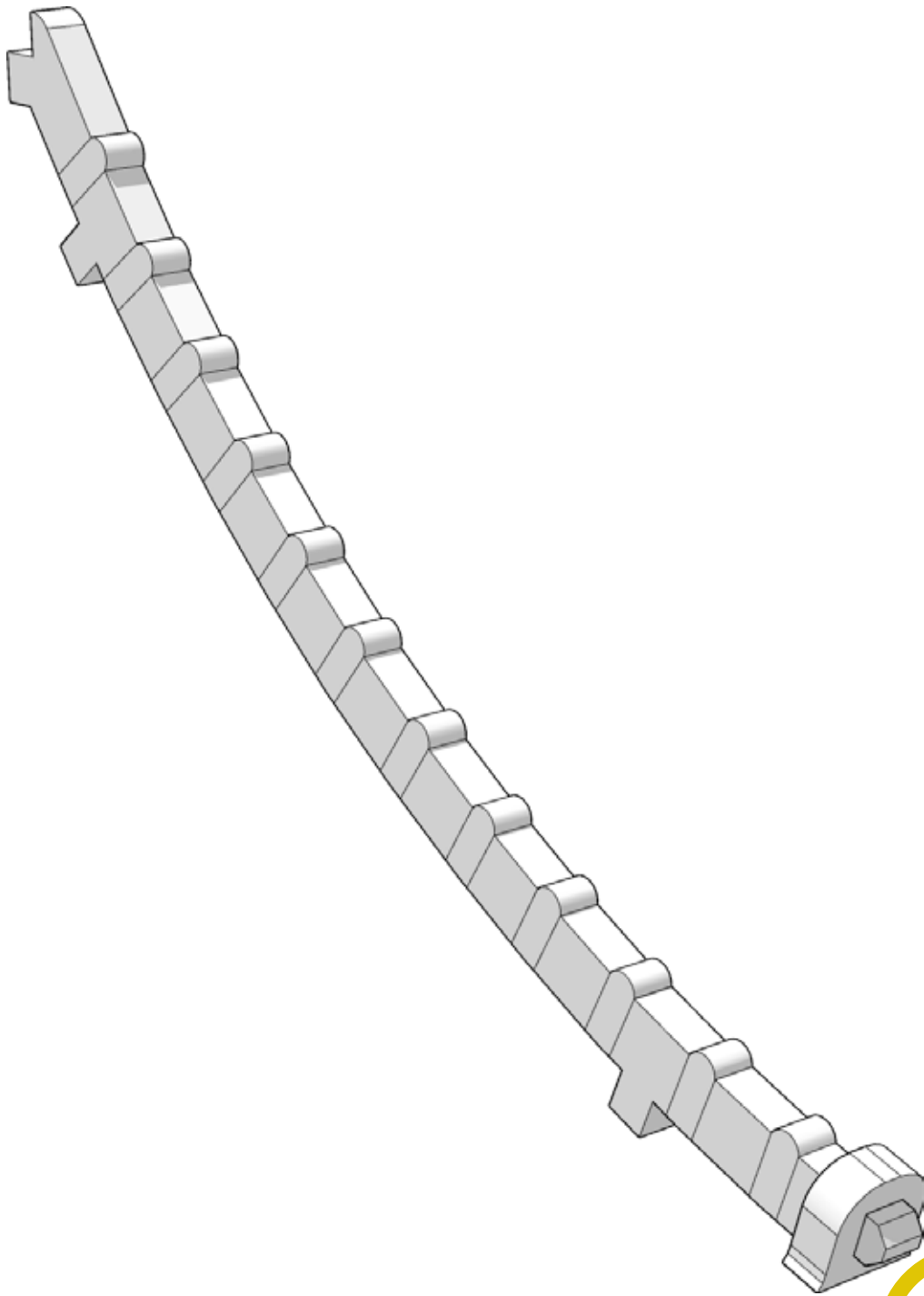

x4



TABLETOP SCENICS

TTSCW-EES-115
Toshi:
Dojo

96

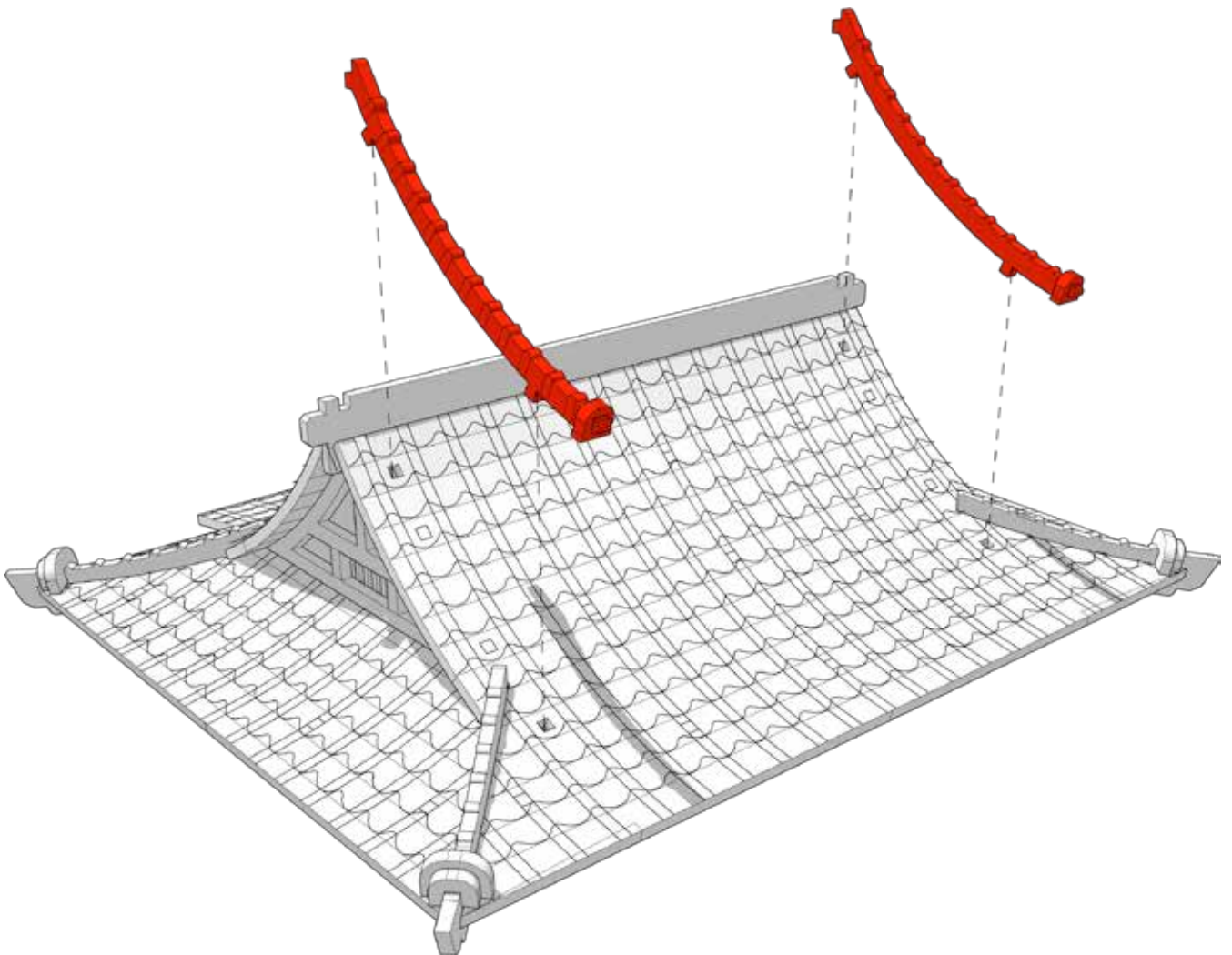



TABLETOP SCENICS

TTSCW-EES-115
Toshi:
Dojo

97

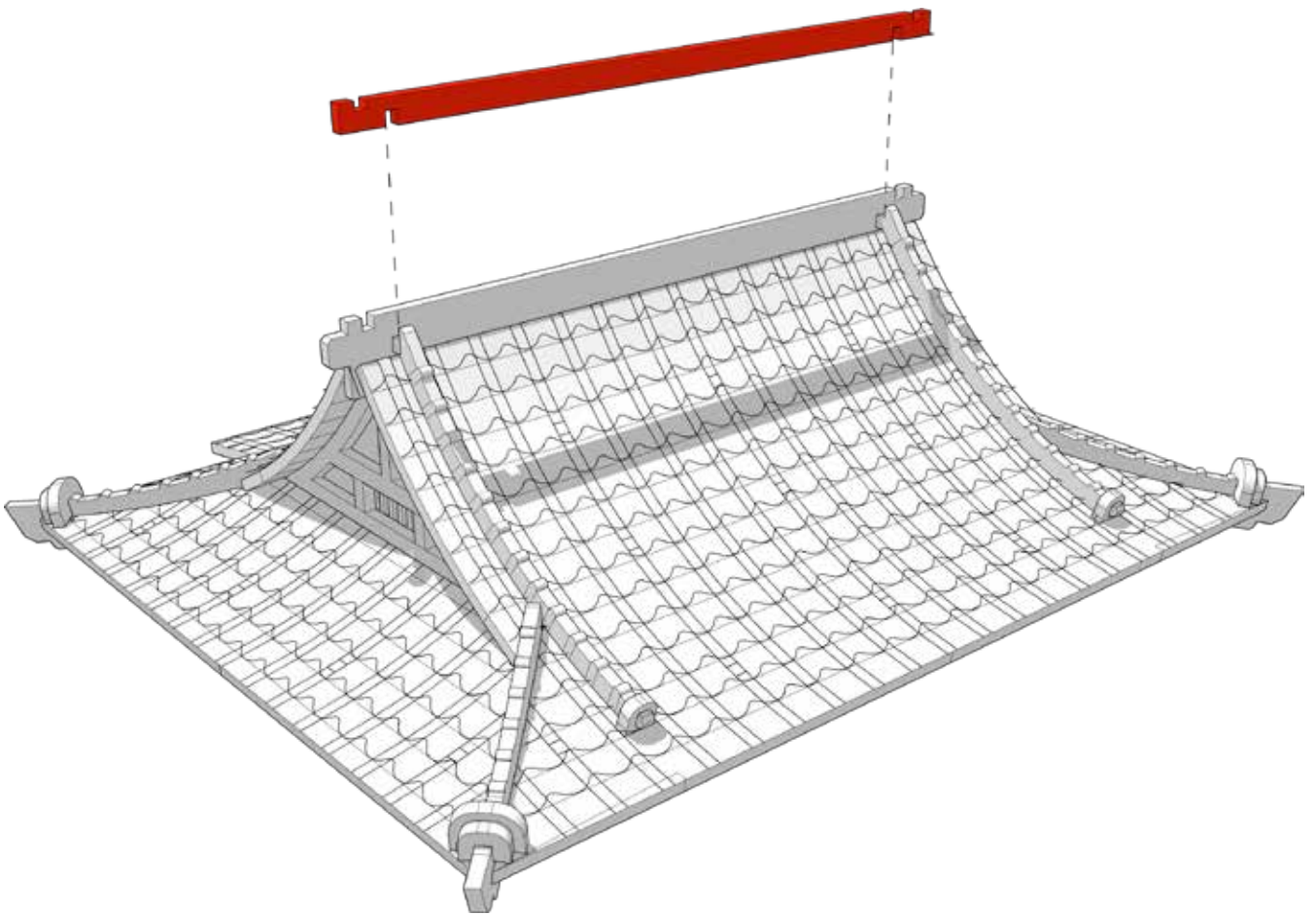



TABLETOP SCENICS

TTSCW-EES-115
Toshi:
Dojo

98

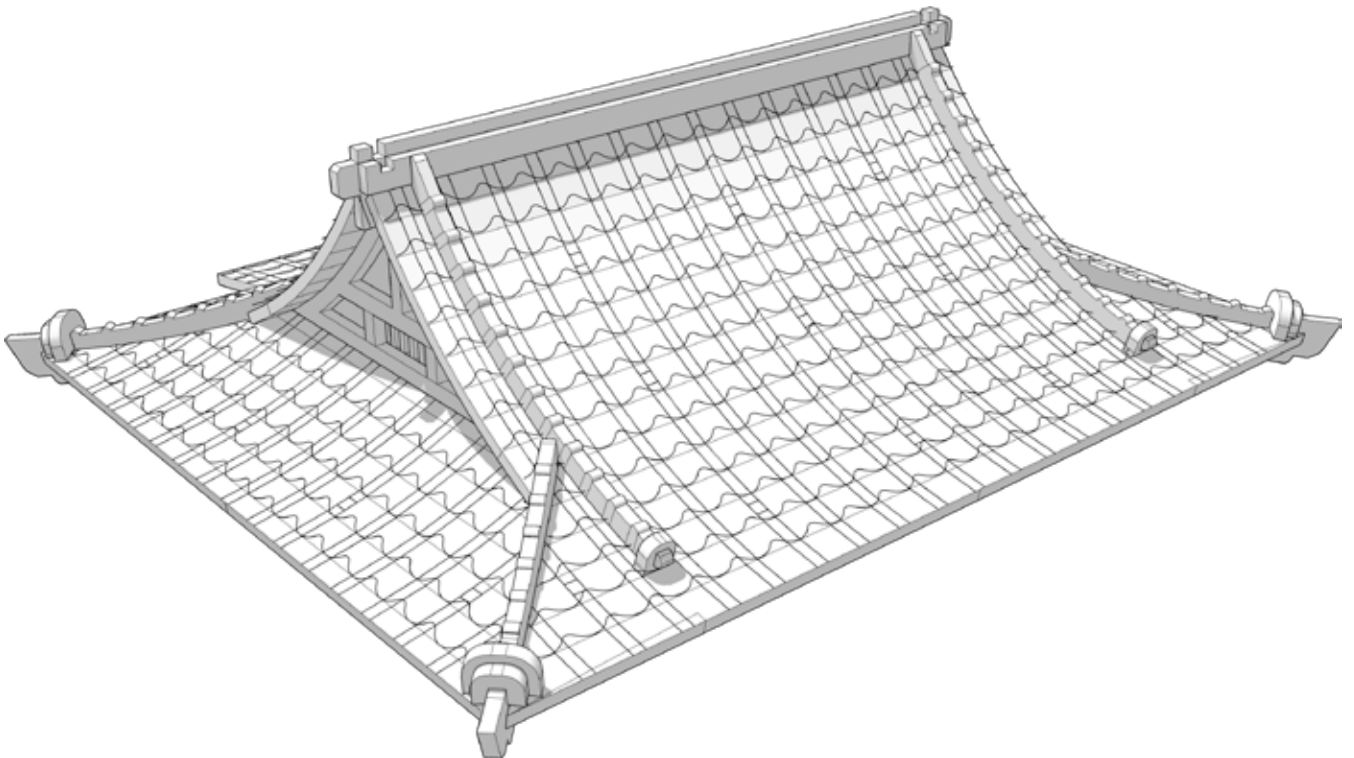



TABLETOP SCENICS

TTSCW-EES-115
Toshi:
Dojo

99

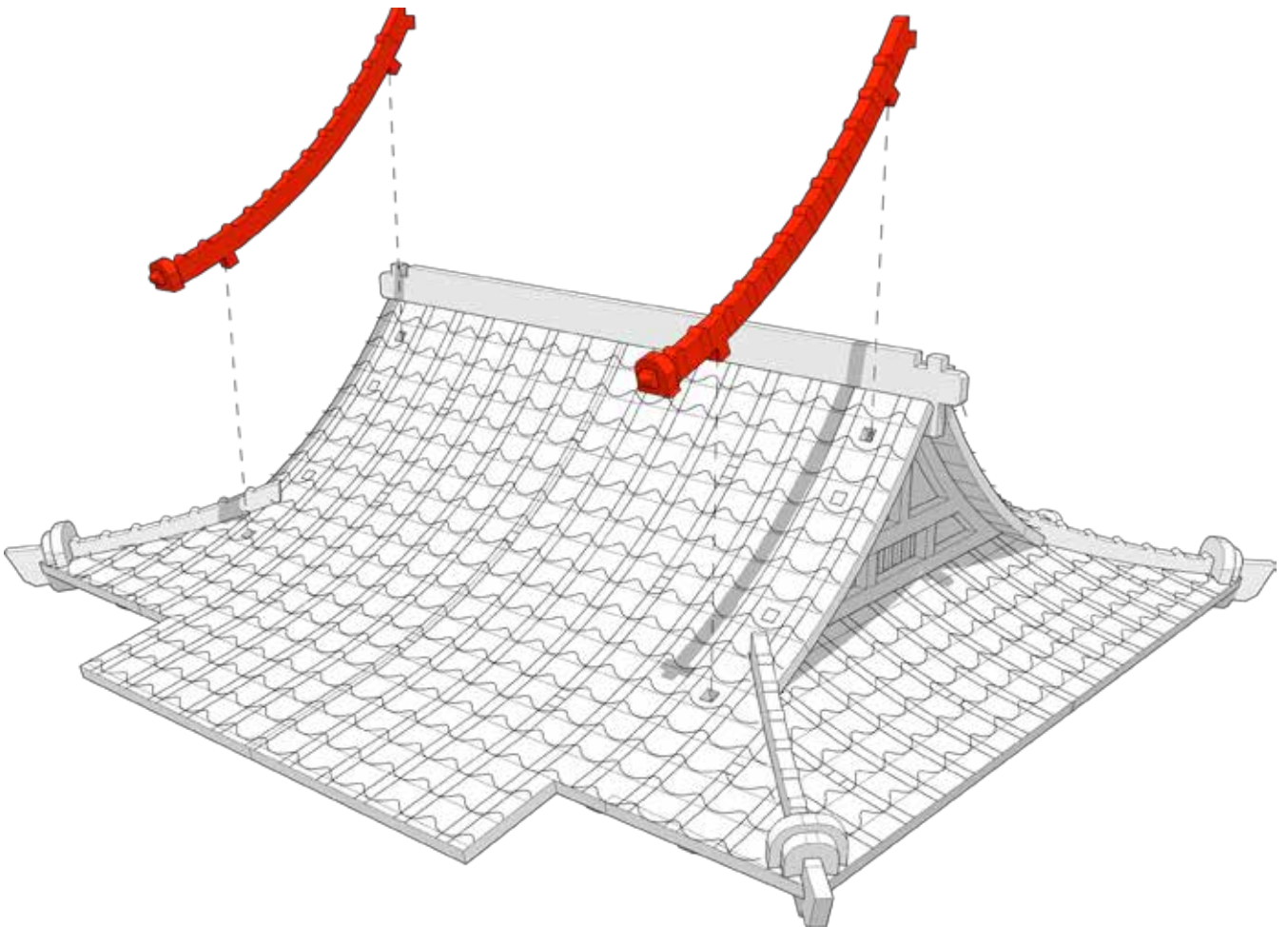



TABLETOP SCENICS

TTSCW-EES-115
Toshi:
Dojo

100

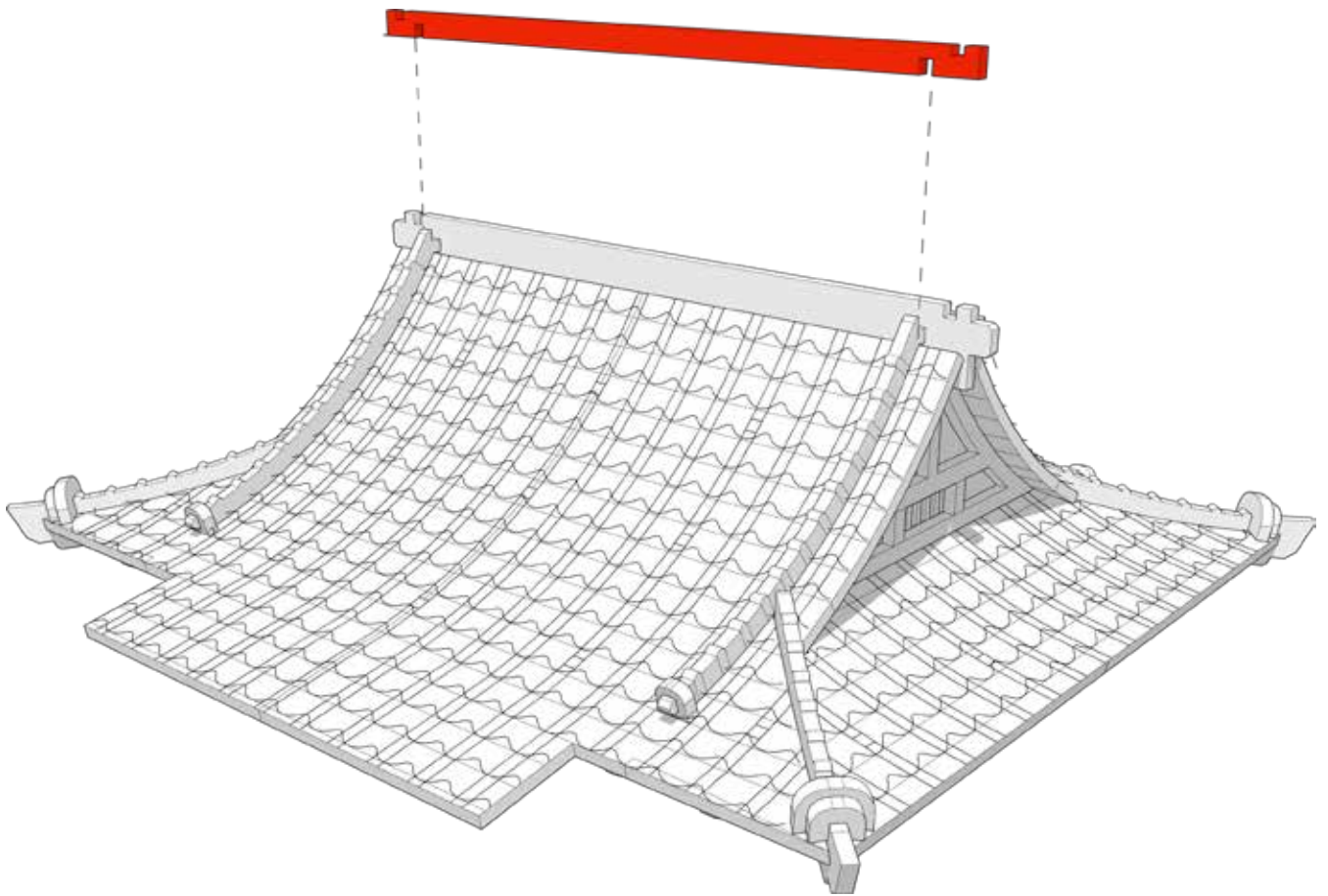



TABLETOP SCENICS

TTSCW-EES-115
Toshi:
Dojo

101

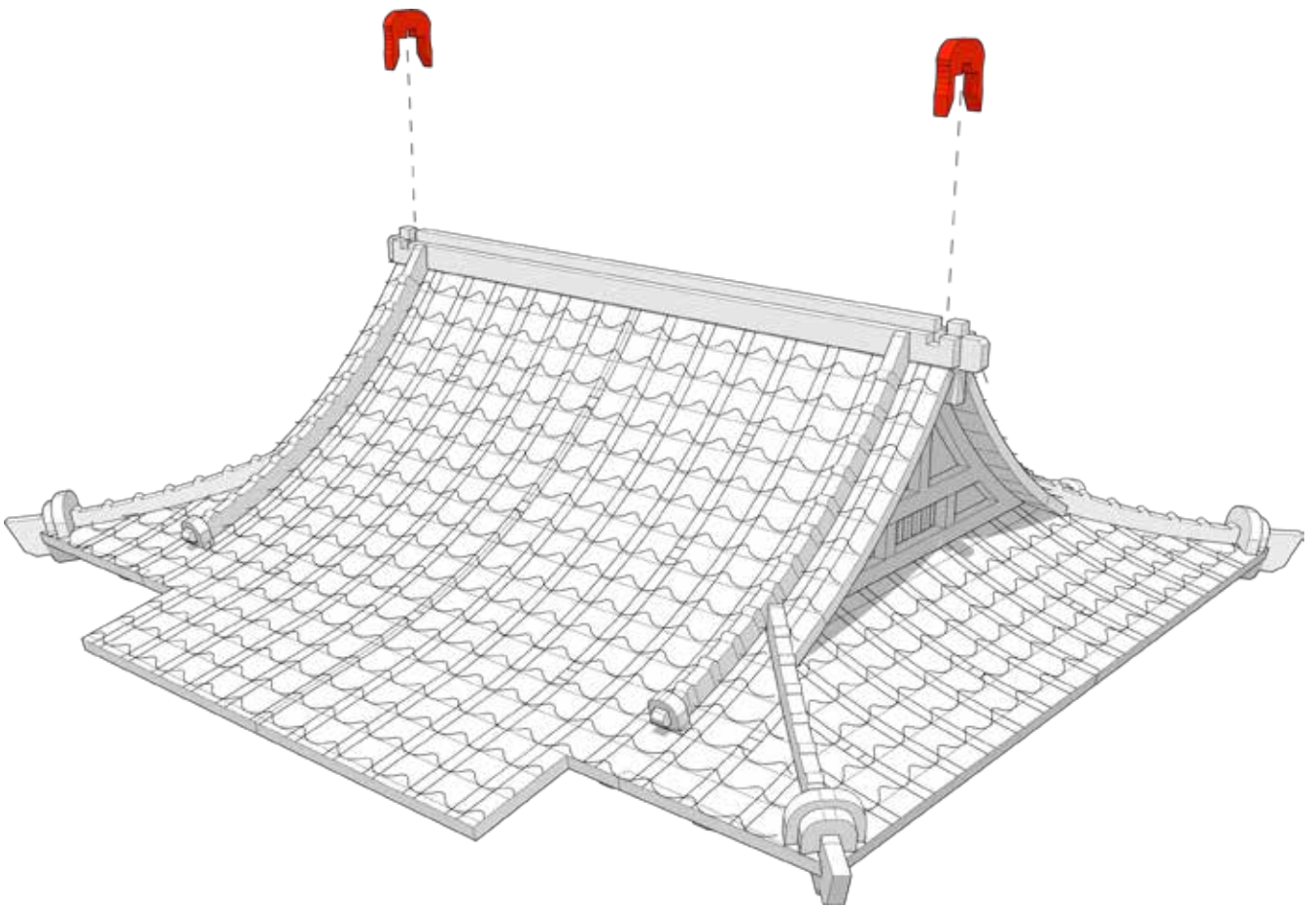



TABLETOP SCENICS

TTSCW-EES-115
Toshi:
Dojo

102

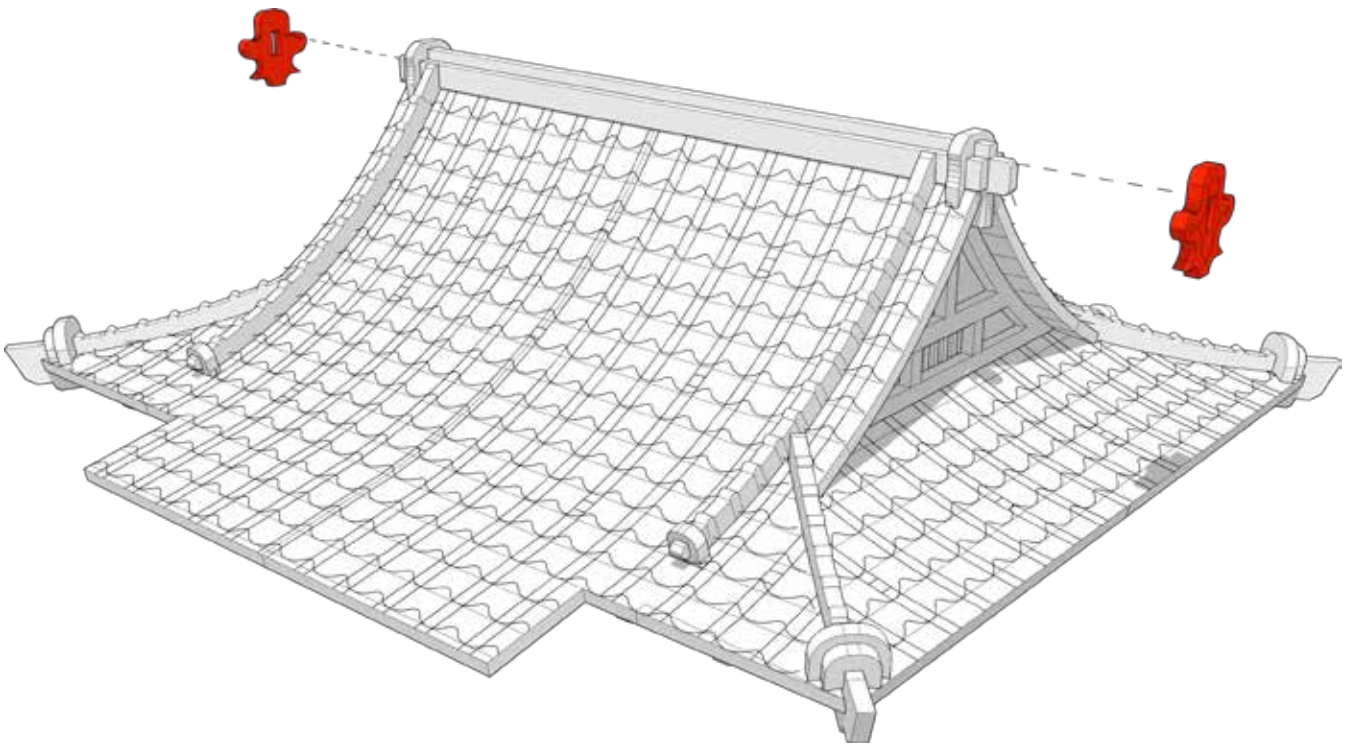



TABLETOP SCENICS

TTSCW-EES-115

Toshi:

Dojo

103

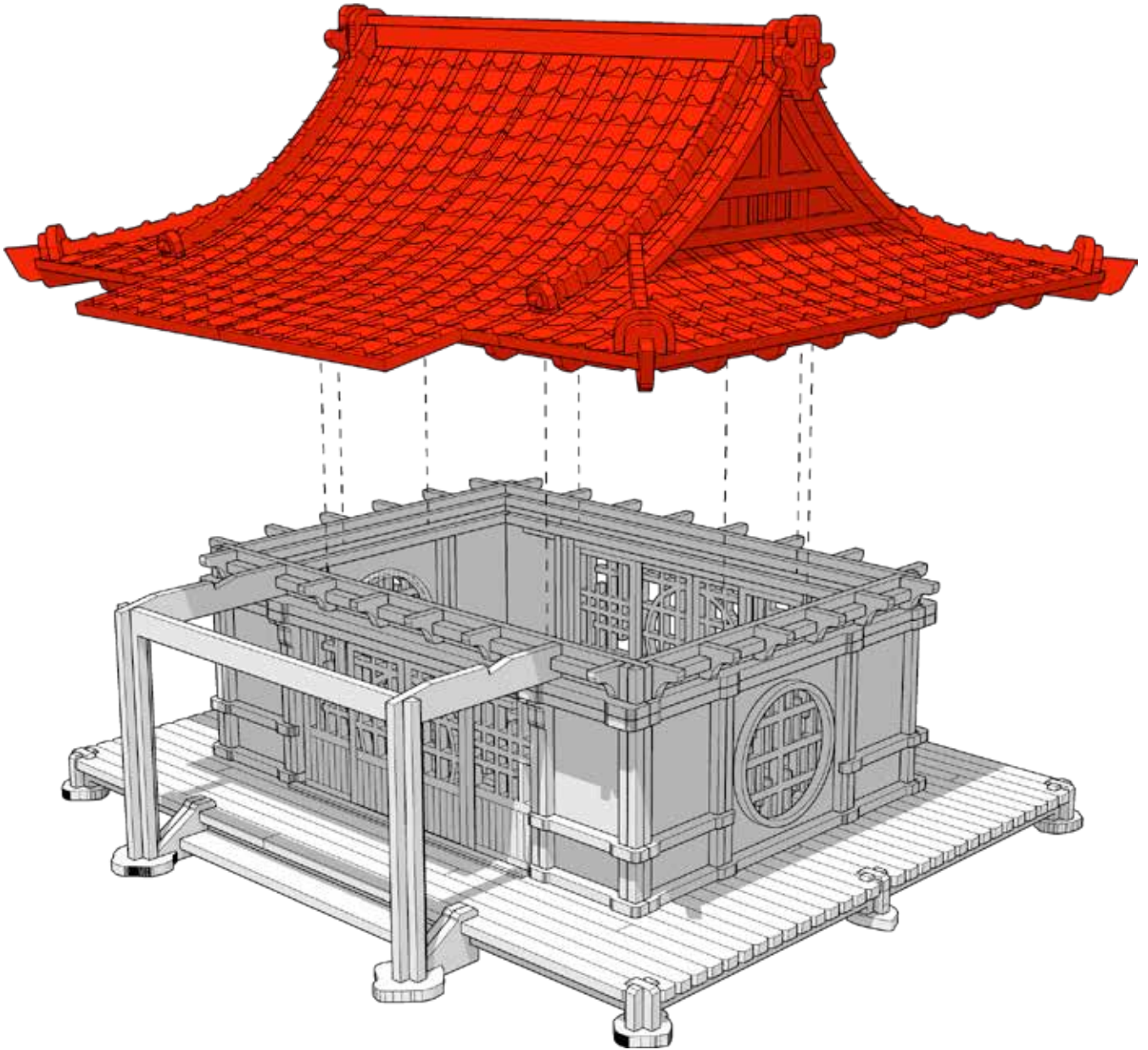



TABLETOP SCENICS

TTSCW-EES-115
Toshi:
Dojo

104

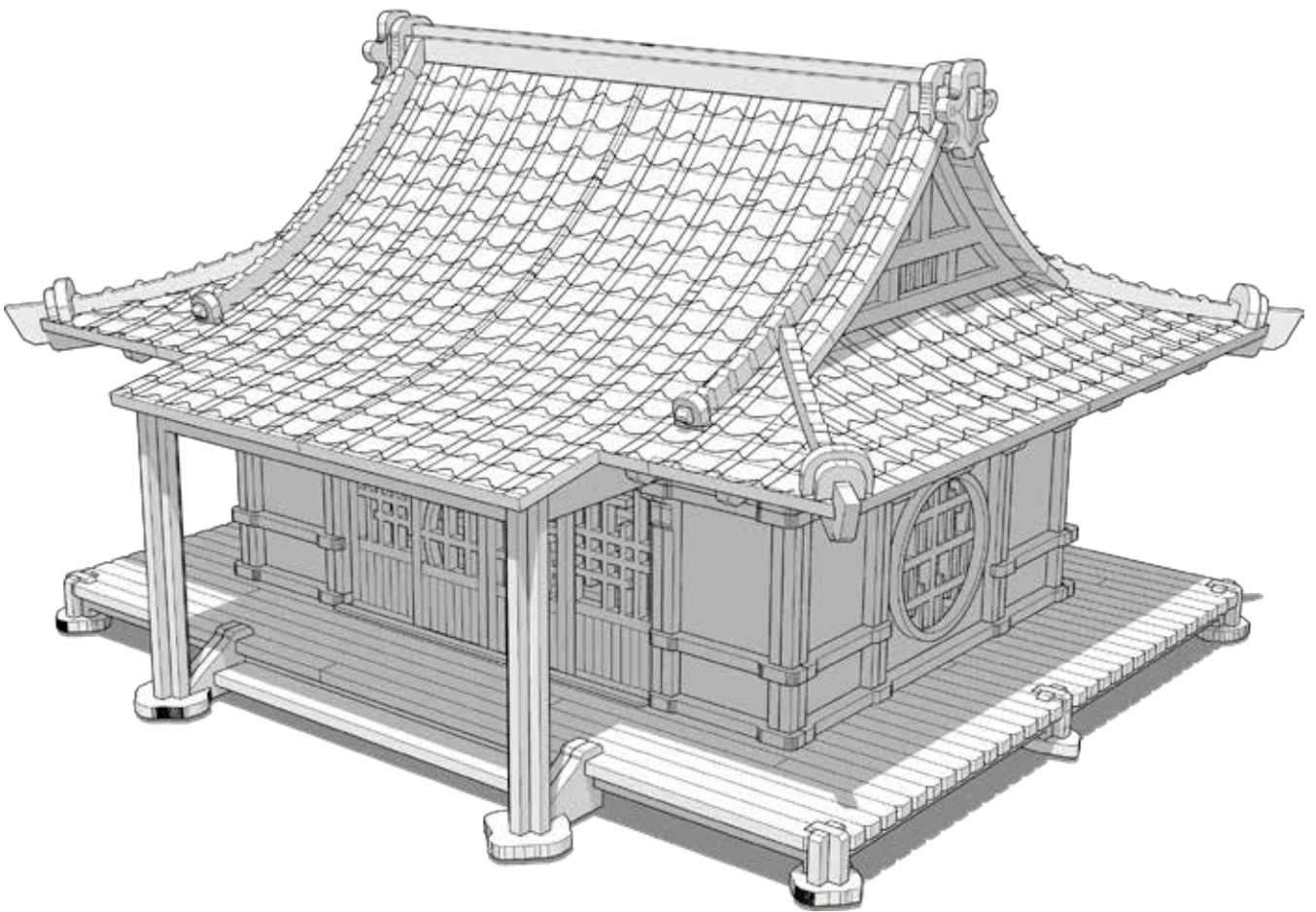



TABLETOP SCENICS

TTSCW-EES-115
Toshi:
Dojo

105