

Liberty Pumps®

RE/REX-Series



3
Year Warranty



Available with
LSG or LSGX-Series
(2-Stage) Grinders



Retro-Fit Systems for E/One® Grinder Packages

**A Completely
Assembled Grinder
Replacement
Package for E/One®
GP200, GP2000 and
Extreme Systems**

Features:

- Liberty's 2 hp Omnivore grinder pump - available in single stage or two stage
- Fully assembled and ready to drop-in-place
- IP68 Waterproof junction box contains motor contactor and terminal strip
 - Includes floats, piping and replacement cover
 - Sealed 6 pin, quick-connector with 10' cable lead plugs into existing E/One connector. Both old style and new hooded connectors available (see models selection)
- Heavy-duty cast iron anti-siphon check valve
- Alarm float works as a redundant "on" float. Will sound alarm and activate pump in the event of a main switch failure
- Stainless steel piping and discharge elbow is easily adjusted for proper engagement to the receiver
- Original equipment manual over-ride switch remains operable.

innovate. evolve.

E/One® is a registered trademark of Environment One Corporation and is not affiliated with Liberty Pumps

Retro-Fit Systems for E/One® Grinder

The RE/REX-Series is engineered as an easy drop-in core replacement for E/One® GP200, GP2000 and Extreme D-Series systems. The newly up-graded design gives you all the power of Liberty's Omnivore® grinder with patented V-Slice® cutter technology. Choose from two performance levels – Liberty's LSG single stage design with a maximum head of 108 feet or the LSGX 2-stage model with heads to 185 feet. Improved features include an easily adjusted goose neck discharge, cam-lock cover system and high-mount junction/control box that elevates it above the potential flood level in the event of a power failure. E/One® original equipment panels remain fully operational (including the manual over-ride switch) when connected to the Liberty unit.

E/One® is a registered trademark of Environment One Corporation and is not affiliated with Liberty Pumps

8' drop rope included with system



Stainless Steel discharge piping and pump support.



10' cable is pre-wired

inno

RE/REX-Series Features

“REX” models



“RE” models



Sealed 6 pin connectors:
Available in two styles. Order “RE” models for older style GP200/GP2000 systems or “REX” models for the newer Extreme D-series hooded connector.

High-mount junction/control box.
Mounts to the existing vent pipe higher in the basin’s access chamber using 2 stainless steel hose clamps and mounting brackets.



NEW! K001630
Adapter harness converts “RE” style connector to “REX” style (sold separately).



Cam-lock cover system.
No more lost bolts or unsecured covers. Simply drop the system in place and turn the three cam-locks to “closed” using a 9/16” socket.

Easily adjusted discharge height.
Simply slide the discharge up or down for the proper height adjustment and then tighten the 3 compression bolts for a secure connection. 3-ring gasket for receiver engagement provides a leak-proof seal.



Heavy-duty cast iron anti-siphon check valve.



Dual-purpose float:
Alarm float works as a redundant “on” float. Will sound the alarm and activate the pump in the event of a main switch failure.



Retro-Fit System for E/One® Grinder Packages

Performance Curves:

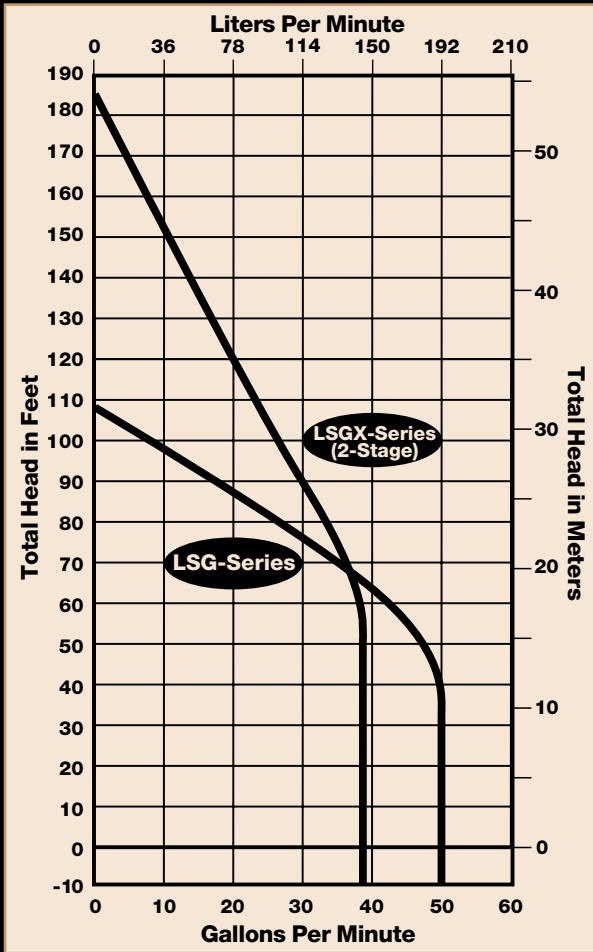

Dimensional Data

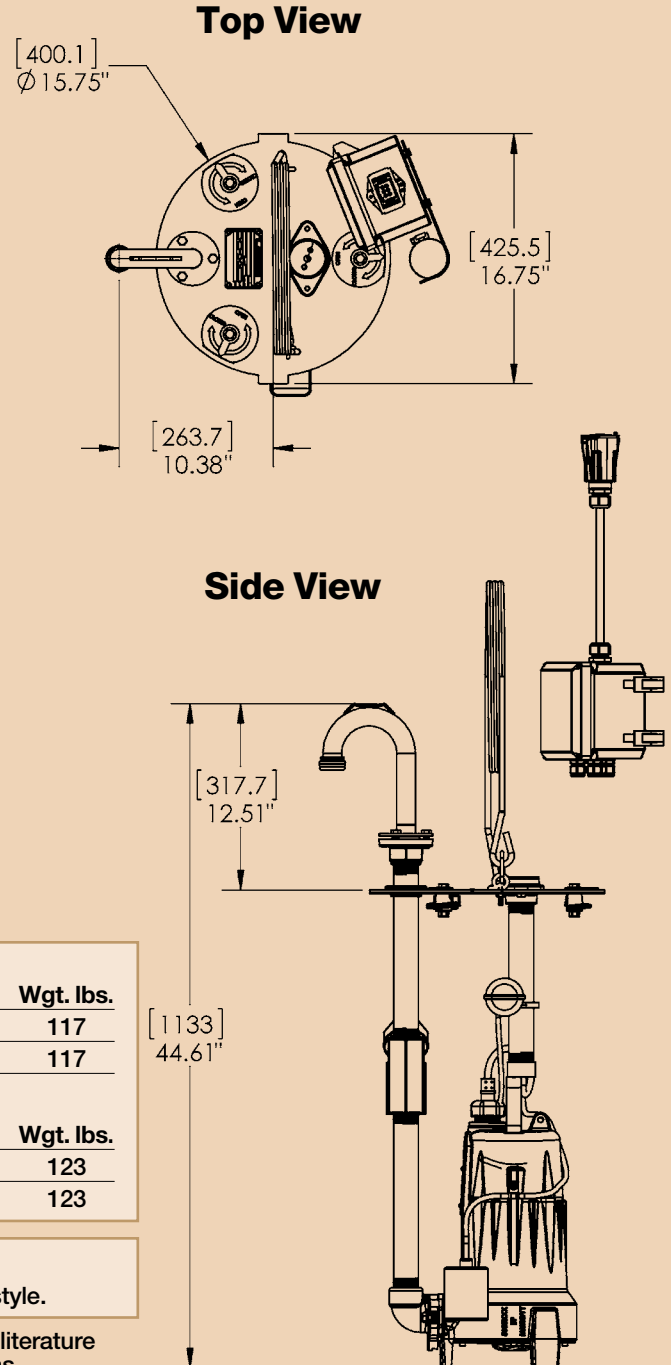

Models

Single Stage LSG-Series

Liberty Model	E/One® Model	Hp.	Volts	Amps	Hz.	Wgt. lbs.
LSG202-RE	Fits GP200 and GP2000	2	208-230	15	60	117
LSG202-REX	Fits Extreme D-Series	2	208-230	15	60	117

2-Stage LSGX-Series

Liberty Model	E/One® Model	Hp.	Volts	Amps	Hz.	Wgt. lbs.
LSGX202-RE	Fits GP200 and GP2000	2	208-230	15	60	123
LSGX202-REX	Fits Extreme D-Series	2	208-230	15	60	123

Accessories

K001630 Adapter harness. Converts 6 pin RE-style connector to REX style.

E/One® is a registered trademark of Environment One Corporation and is not affiliated with Liberty Pumps

See LSG or LSGX series grinder literature for complete pump specifications.

Single stage LSG units may not meet pressure requirements in all applications; use of 2-stage LSGX may be required. Consult factory for proper sizing and technical assistance where forced pressure mains or multiple homes tie into a common waste line.



US Certified Pump

Liberty Pumps • 7000 Apple Tree Avenue • Bergen, New York 14416
Phone 800-543-2550 Fax (585) 494-1839

Specifications are subject to change without notice. Copyright © Liberty Pumps, Inc. 2017 All rights reserved. LLIT4200 R08/17

www.libertypumps.com