



GREASE MANAGEMENT

ENDURA SECTION 22 13 23 GREASE INTERCEPTORS



Engineering grease management solutions for plumbing and food service professionals

About Us



Molding a Better Future

One of North America's leading producers of plastic products for the building and construction industries specializing in injection molded products. We have five decades of expertise and experience in the manufacturing and distribution of plastic plumbing products, processing multiple materials and producing millions of fittings and products on an annual basis.

Endura® grease interceptors have demonstrated effective, efficient and consistent performance with over a decade of field installation and operation. The Endura® products are multi-patented and built to withstand the toughest environments, providing the flexibility of in-floor, on-floor and semi-recessed application. We have been instrumental in changing the traditional practices regarding the installation of grease management solutions, plastic alternatives to metal interceptors being now substantially accepted Nationwide as the new standard for grease management in commercial foodservice applications.

Endura® Earth friendly solutions for Grease Management

We are committed to the continuous improvement of our environmental performance and to meeting or exceeding the requirements of all applicable environmental laws and regulations.

Durability

- Fewer installations and replacements result in lower lifetime costs & less landfill waste.
- Injection molded in engineered thermoplastics, Endura® Grease Interceptors will not corrode, chip, or peel, even under the most severe applications
- Durability provides consistent operation – no compromise of effectiveness due to deterioration of key parts

Green by Design



- Light-weight but durable grease interceptor units enable smaller carbon footprint and low-emissions transport
- Injection and rotationally molded thermoplastic requires less energy to produce than metal grease interceptors
- Endura® interceptors are manufactured using up to 100% recompounded material

Product Overview

Internal Application Grease Interceptors



Endura® Compact 7GPM - 10GPM - 15GPM Models

3907A02 - 7GPM (0.44 LPS) 2" (51 mm) connection
3910A02 - 10GPM (0.63 LPS) 2" (51 mm) connection
3915A02C - 15GPM (0.94 LPS) 2" (51 mm) connection

Compact models use a development of the patented Endura baffle system to enhance separation performance at low flow rates. EZ-Clean tank design – Aids exterior cleaning.



Endura® Lo-PRO Grease Interceptor 25GPM Model

3925A02LO 25GPM (1.6 LPS) 2" (51 mm) connection

Endura® Lo-PRO for tight on-floor applications where space is at a premium. Same dimensional footprint as 35gpm and 50gpm Endura® models. Overall height 11 inches, still meeting requirements of ASME112.14.3. Internal components can be removed in less than 6" of additional clearance.



Endura® 20GPM

3920A02 20GPM (1.26 LPS) 2" (51 mm) connection

Our original tank, 20gpm units are perhaps the most commonly installed product. It suits on-floor and in-floor application respectively.



Endura® 25GPM - 35GPM Models

3925ALT02 25GPM (1.6 LPS) 2" (51 mm) connection
3925ALT03 25GPM (1.6 LPS) 3" (76 mm) connection
3935A03 35GPM (2.2 LPS) 3" (76 mm) connection
3935A04 35GPM (2.2 LPS) 4" (110 mm) connection

35gpm uses structured foam molding technology provides rigidity and durability while reducing unit weight. Diffuser baffle aids separation at increased flow rates.



Endura® 50GPM Models

3950A03 50GPM (3.2 LPS) 3" (76 mm) connection
3950A04 50GPM (3.2 LPS) 4" (110 mm) connection

A tall version of our 35gpm model the 50gpm interceptor uses common parts incorporating all the best features of the Endura® product design in a comparatively light weight solution to that of its metal competitors.



Endura® XL 75GPM Models

4075A04 75 GPM (4.74 L/Sec) 4" (110 mm) Connections
4075A04T 75 GPM (4.74 L/Sec) 4" (110 mm) FPT Connections

Industry leading separation efficiency based on testing to national standards. Comparable operational grease capacity (580 lb) to 750 gallon Gravity GI (Concrete).* Operation based on Dynamic Inlet Baffle (Pat. Pend.) with internal flow control device. Smart tank design offers many features, with external flow control available as an option. Cut-to-length riser system for burial up to 72", pre-plumbed outlet system, traffic rated dual cover format for unrivalled maintenance accessibility & inspection.



Endura® XL 100GPM Models

40100A04 – 100GPM (6.3 L/Sec) 4" (110 mm) Connections
40100A04T – 100GPM (6.3 L/Sec) 4" (110 mm) FPT Connections

Industry leading separation efficiency based on testing to national standards. Comparable operational grease capacity (1058 lb) to 1500 gallon Gravity GI (Concrete).* Operation based on Dynamic Inlet Baffle (Pat. Pend.) with internal flow control device. Smart tank design offers many features, with external flow control available as an option. Cut-to-length riser system for burial up to 72", pre-plumbed outlet system, traffic rated dual cover format for unrivalled maintenance accessibility & inspection.

* based on 25% rule for maintenance

Grease Interceptors – Generic Types

The grease management industry has developed significantly in the past decade with not only more advanced and improved products but also development of performance standards and harmonization of common terms and references.

Traditionally the term “Grease Trap” was commonly applied and is still used in the industry today. This term is progressively disappearing from nomenclature and technical references based on an industry wide recognition that the term “trap” would suggest the presence of a water seal, integrally located within the interceptor. This practice substantially ceased many years ago, modern interceptors being designed to be installed in conjunction with external water seal traps as a standard part of the system.

In addition to this clarification, with publication of the 2006 UPC plumbing code three generic types of Grease Interceptor were introduced and have since become the industry standard for designating the type of interceptor being considered.

Generically the application of a Grease Interceptor regardless of type is defines as follows:

Grease Interceptor: “A plumbing appurtenance or appliance that is installed in a sanitary drainage system to intercept nonpetroleum fats, oil, and grease (FOG) from a wastewater discharge.

Specific characteristics then define the three types of Interceptor:

Hydromechanical Grease Interceptor (HGI)

“An HGI is sized by flow rate (GPM) and qualified separation/retention efficiency, validated against National performance Standards. An HGI incorporates a defined means of flow control, acts to entrain air to influent, includes interior baffling, or barriers in combination or separately, working to promote hydromechanical separation. HGIs are generally installed inside the facility they serve.”

Gravity Grease Interceptor (GGI)











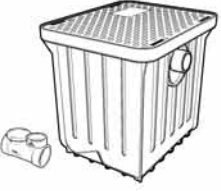

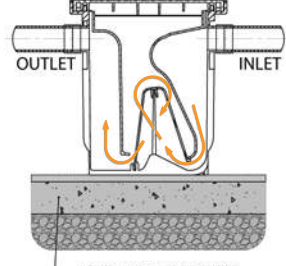
“A GGI is characterized by volume, minimum 30 minute retention time, baffle(s), not less than two compartments, a total volume of not less than 300 gallons (1135 L), and gravity separation. If not recognized by an official body, a GGI will be designed by a registered professional engineer. GGI's are generally installed outside the building they serve and buried below grade.”



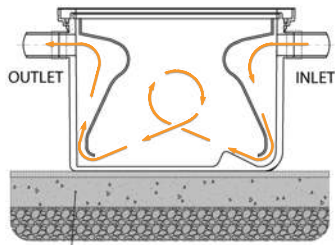
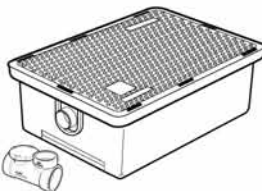

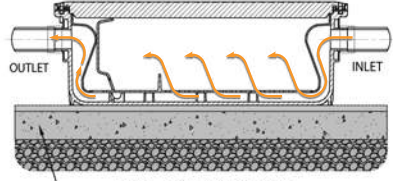
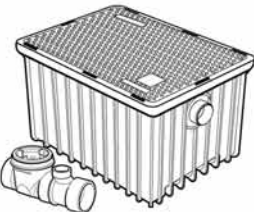

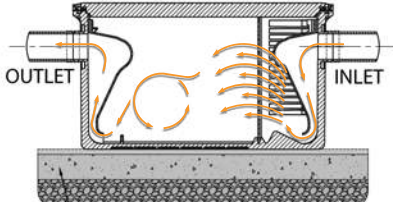
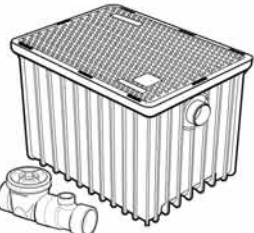

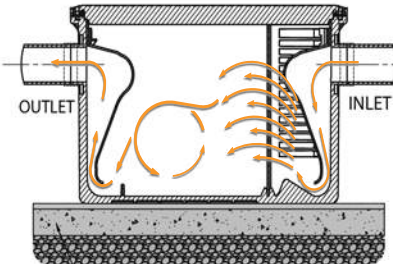

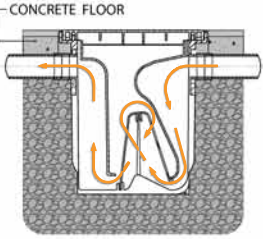
Grease removal Device (GRD)

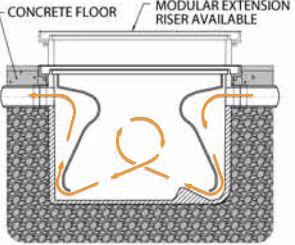
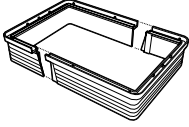
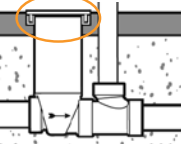
A GRD is a hydromechanical grease interceptor that mechanically removes non-petroleum fats, oils and grease (FOG) from the separation chamber, the control of which is either automatic or manually initiated and involves maintaining liquefied state of intercepted FOG by heating. GRD's are installed inside the facility they serve.”

Hydromechanical Grease Interceptor VS. Other Grease Interceptors

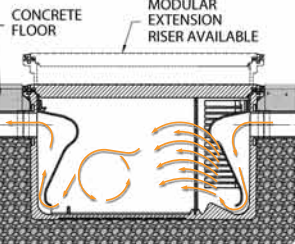
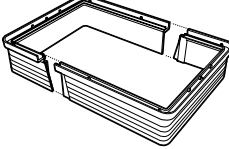
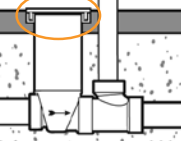
	Endura (HGI)	Endura XL (HGI)	Hydromechanical Grease Interceptors (HGI)	Gravity Grease Interceptors (GGI)	Grease Removal Device (GRD)
	7-50gpm	75-100gpm			
National Performance Standards	- PDI G101 - CSA B481 - ASME A112.14.3	- PDI-G101 - CSA B481 - ASME A112.14.3 (Type A/C)	- PDI-G101 - CSA B481 - ASME A112.14.3	None	- PDI-G101 - CSA B481 - ASME A112.14.4
Plumbing Code Approvals/Listing	- UPC - IPC - NPCC - NSPC	- UPC - IPC - NPCC - NSPC	- UPC - IPC - NPCC - NSPC	- UPC (500 USG+) - IPC (300 USG+) - NPCC - NSPC	- UPC - IPC
Specific AHJ Approval	Typically Not	Typically Not	Typically Not	Yes	Yes
Material	Plastic (PP- Polypropylene)	Plastic (PE/PP)- Polyethylene/ Polypropylene)	- Cast Iron - Epoxy Coated Steel - Plastic (PE)	- GRP/Fiberglass - Concrete - Steel	Stainless Steel
Efficiency	93%-99% - Based on ASME A112.14.3 - Tested to breakdown	=>98% - Based on ASME A112.14.3 - Tested to NSF ES15741	Min 90% (based on Performance Standards)	No Assessment Possible	Min 90% (based on Performance Standards)
Average Lifespan	Min 20 years - Typically life of system	Min 20 years - Typically life of system	- Cast Iron (10-15 yrs) - Epoxy Coated Steel (3-5yrs) - Plastic (PE) (20yrs +)	- GRP/Fiberglass (20yrs+) - Concrete (8-10yrs) - Steel (7-12yrs)	- Tank (10yrs+) - Mechanical (1-3yrs)
Managed Flow	Yes - with Accessible Flow control	Yes – Internal and External Accessible Flow control	Yes (Required for PDI compliance)	No	Yes
Cost Ratio Index - Product	1	0.6 (vs. GGI) 0.9 (vs. HGI – Traditional Materials) 1-1.2 (vs. Plastic HGI)	.9 - 1.5	8-10	6-8
Annual Operation Cost Ratio (Assumes third party service)	1	0.75 (vs. GGI) 0.9 (vs. HGI – Traditional Materials) 0.9 (vs. Plastic HGI)	1	8-10	0.5-1
Footprint Ratio	1	0.3 (vs. GGI) 0.9-1.2 (vs. HGI – Traditional Materials) 1.1 (vs. Plastic HGI)	1	Min 10	1
Sizing Method	Flow Rate	Flow Rate / Pipe Size	Flow Rate / Pipe Size	Capacity (US Gallons)	Flow Rate / Pipe Size
Typical Installation Time	- On-Floor - 2-3hrs - In Floor - 4-6hrs	- On-Floor - 2-3hrs - In Floor – 4-8hrs	- On-Floor - 2-3hrs - In Floor - 4-8hrs	12-15hrs	2-4hrs
Nature of Installation	- Licensed Plumber - Common tools/practices	- Licensed Plumber/ Ground worker - Earthmoving/ Excavation (below grade)	- Licensed Plumber - Common tools/practices	- Licensed Plumber/ Groundworker - Earthmoving/Excavation	- Licensed Installer - Common tools/practices
Installer Profile	- Licensed Plumber	- Licensed Plumber	- Licensed Plumber	- Licensed Plumber (Hook Up) - Ground worker (Install)	- Licensed Plumber - Licensed Electrician
Product Availability	- Stock Item - National/Regional/ Local Plumbing Wholesale - Restaurant Equipment Distributors	- Stock Item - National/ Regional/ Local Plumbing Wholesale	- National/Regional/ Local Plumbing Wholesale - Restaurant Equipment Distributor	- Local/Regional Manufacturer Direct - Special Order -Regional/Local Plumbing Wholesale	- Manufacturer Direct - Local Representation

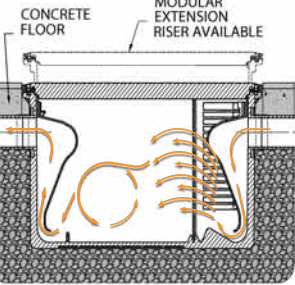
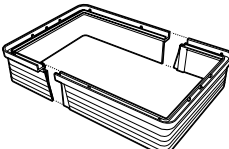
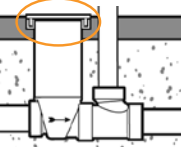
Product	Description	Connection Size	Recycled Content	On-Floor
 <p>Endura® Compact Grease Interceptor - 7 GPM 3907A02 - 10 GPM 3910A02 - 15 GPM 3915A02C (Suffix "T" for threaded inlet/outlet connections)</p>	<ul style="list-style-type: none"> - Compact tank / small footprint - Injection molded in proven engineered thermoplastics for strength and durability - EZ-Open cover latches - Odor lock cover gasket - Load rated cover supports up to 440 lb (220kg) of pedestrian and light duty traffic - EZ-Clean exterior tank profile with a non-ribbed section at the lower two inches of the tank - 10 Year Limited Manufacturers Warranty 	- 7 GPM 3907A02 - 2" - 10 GPM 3910A02 - 2" - 15 GPM 3915A02C - 2"  Connected using mechanical joint couplings allowing for use of various piping materials.	Minimum of 5% 	 LEVEL, NON-ABSORBENT MATERIAL FOR EVEN SUPPORT OF TANK
 <p>Endura® Grease Interceptor - 20 GPM 3920A02 (Suffix "T" for threaded inlet/outlet connections)</p>	<ul style="list-style-type: none"> - Injection molded in proven engineered thermoplastics for strength and durability - EZ-Open cover latches - Odor lock cover gasket - Load rated cover supports up to 440 lb (220kg) of pedestrian and light duty traffic - 10 Year Limited Manufacturers Warranty 	- 20 GPM 3920A02 - 2"  Connected using mechanical joint couplings allowing for use of various piping materials.	Minimum of 5% 	 LEVEL, NON-ABSORBENT MATERIAL FOR EVEN SUPPORT OF TANK
 <p>Endura® Low Profile Grease Interceptor - 25 GPM 3925A02L0 (Suffix "T" for threaded inlet/outlet connections)</p>	<ul style="list-style-type: none"> - 11" in height, ideal for under sink installation - Requires only 6" of clearance for maintenance - Injection molded in proven engineered thermoplastics for strength and durability - EZ-Open cover latches - Odor lock cover gasket - EZ-Clean tank exterior - 10 Year Limited Manufacturers Warranty 	- 25 GPM 3925A02L0 - 2"  Connected using mechanical joint couplings allowing for use of various piping materials.	Minimum of 5% 	 LEVEL, NON-ABSORBENT MATERIAL FOR EVEN SUPPORT OF TANK
 <p>Endura® Grease Interceptor - 25 GPM 3925ALT02 - 35 GPM 3935A03 - 25 GPM 3925ALT03 - 35 GPM 3935A04 (Suffix "T" for threaded inlet/outlet connections - 3925ALT03 / 3935A03 only)</p>	<ul style="list-style-type: none"> - Injection molded in proven engineered thermoplastics for strength and durability - EZ-Open cover latches - Odor lock cover gasket - Load rated cover supports up to 440 lb (220kg) of pedestrian and light duty traffic - 10 Year Limited Manufacturers Warranty - Supplied with 2 piece flow control 	- 25 GPM 3925ALT02 - 2" - 25 GPM 3925ALT03 - 3" - 35 GPM 3935A03 - 3" - 35 GPM 3935A04 - 4"  Connected using mechanical joint couplings allowing for use of various piping materials.	Minimum of 5% 	 LEVEL, NON-ABSORBENT MATERIAL FOR EVEN SUPPORT OF TANK
 <p>Endura® Grease Interceptor - 50 GPM 3950A03 - 50 GPM 3950A04 (Suffix "T" for threaded inlet/outlet connections - 3950A03 only)</p>	<ul style="list-style-type: none"> - Injection molded in proven engineered thermoplastics for strength and durability - EZ-Open cover latches - Odor lock cover gasket - Load rated cover supports up to 440 lb (220kg) of pedestrian and light duty traffic - 10 Year Limited Manufacturers Warranty - Supplied with 2 piece flow control 	- 50 GPM 3950A03 - 3" - 50 GPM 3950A04 - 4"  Connected using mechanical joint couplings allowing for use of various piping materials.	Minimum of 5% 	 LEVEL, NON-ABSORBENT MATERIAL FOR EVEN SUPPORT OF TANK

In-Floor	Extension Riser	Flow Control Extension	Standards Conformance	Listings	Thermal Capability	Remarks
 <p>CONCRETE FLOOR</p> <ul style="list-style-type: none"> • Check local codes for acceptance of in-floor installation • Finish to floor level accommodating requisite materials, E.G. Tile, mortar, etc. 	N/A	N/A	 <p>* Excluding 7 GPM</p>	<p>NYC Commonwealth of Massachusetts</p> 	Continuous discharge at 104°C (220°F)	<p>3-Part Master Format Specifications, CAD drawings & BIM drawings available at ARCAT.com</p> <p>Installation Guide contact tech-support@endurainterceptor.com</p>
 <p>CONCRETE FLOOR MODULAR EXTENSION RISER AVAILABLE</p> <ul style="list-style-type: none"> • Finish to floor level accommodating requisite materials, E.G. Tile, mortar, etc. 	 <p>6" Modular riser</p> <ul style="list-style-type: none"> - Measurement markings - Stackable up to 3 sets (18" Total) - 3920AX6 	 <p>Sleeve kit for 3" model only, allows access to in-floor flow control device</p> <p>Custom length of SDR 35 or SDR 28 sewer pipe to be used for access sleeve</p> <ul style="list-style-type: none"> - 3" 392203W, 6" SDR 35/28 sewer pipe diameter 		<p>NYC Commonwealth of Massachusetts</p> 	Continuous discharge at 104°C (220°F)	<p>3-Part Master Format Specifications, CAD drawings & BIM drawings available at ARCAT.com</p> <p>Installation Guide contact tech-support@endurainterceptor.com</p>
<p>On-Floor Installation Only</p>	N/A	N/A		<p>NYC Commonwealth of Massachusetts</p> 	Continuous discharge at 104°C (220°F)	<p>3-Part Master Format Specifications, CAD drawings & BIM drawings available at ARCAT.com</p> <p>Installation Guide contact tech-support@endurainterceptor.com</p>
 <p>CONCRETE FLOOR MODULAR EXTENSION RISER AVAILABLE</p> <ul style="list-style-type: none"> • Finish to floor level accommodating requisite materials, E.G. Tile, mortar, etc. 	 <p>6" Modular riser</p> <ul style="list-style-type: none"> - Measurement markings - Stackable up to 3 sets (18" Total) - 3935AX6 	 <p>Sleeve kit allows access to in-floor flow control device</p> <p>Custom length of SDR 35 or SDR 28 sewer pipe to be used for access sleeve</p> <ul style="list-style-type: none"> - 3" 392203W, 6" SDR 35/28 sewer pipe diameter - 4" 392204W, 8" SDR 35/28 sewer pipe diameter 		<p>NYC Commonwealth of Massachusetts</p> 	Continuous discharge at 104°C (220°F)	<p>3-Part Master Format Specifications, CAD drawings & BIM drawings available at ARCAT.com</p> <p>Installation Guide contact tech-support@endurainterceptor.com</p>
 <p>CONCRETE FLOOR MODULAR EXTENSION RISER AVAILABLE</p> <ul style="list-style-type: none"> • Finish to floor level accommodating requisite materials, E.G. Tile, mortar, etc. 	 <p>6" Modular riser</p> <ul style="list-style-type: none"> - Measurement markings - Stackable up to 3 sets (18" Total) - 3935AX6 	 <p>Sleeve kit allows access to in-floor flow control device</p> <p>Custom length of SDR 35 or SDR 28 sewer pipe to be used for access sleeve</p> <ul style="list-style-type: none"> - 3" 392203W, 6" SDR 35/28 sewer pipe diameter - 4" 392204W, 8" SDR 35/28 sewer pipe diameter 		<p>NYC Commonwealth of Massachusetts</p> 	Continuous discharge at 104°C (220°F)	<p>3-Part Master Format Specifications, CAD drawings & BIM drawings available at ARCAT.com</p> <p>Installation Guide contact tech-support@endurainterceptor.com</p>

Dimensions

Endura® 7GPM - 10GPM - 15GPM Models

3907A02 7GPM (0.44 LPS)

2" (51mm) connection

3910A02 10GPM (0.63 LPS)

2" (51mm) connection

3915A02C 15GPM (0.94 LPS)

2" (51mm) connection

Notes: ACCESSIBLE FLOW CONTROL DEVICE (FCD) IS SUPPLIED FOR INSTALLATION UPSTREAM OF THE GREASE INTERCEPTOR (GI) - 2" INLET/OUTLET MODELS

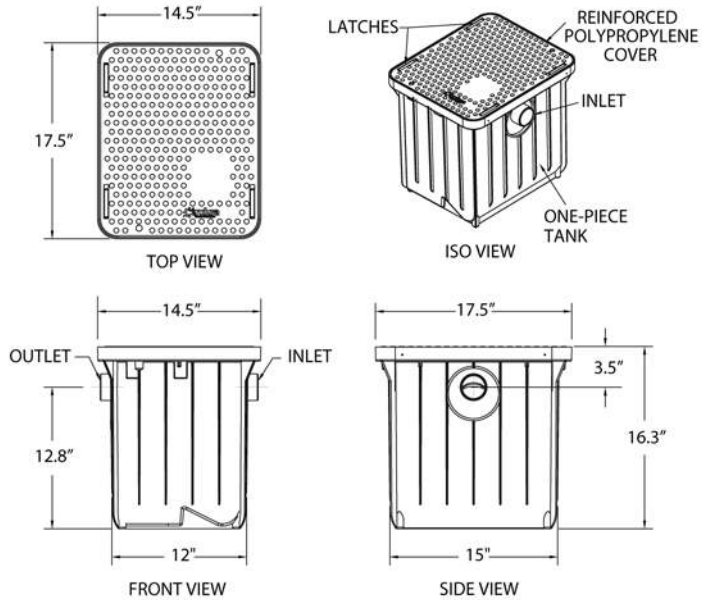
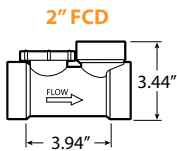

Endura® 20GPM Models

3920A02 20GPM (1.26 LPS)

2" (51mm) connection

Notes: ACCESSIBLE FLOW CONTROL DEVICE (FCD) IS SUPPLIED FOR INSTALLATION UPSTREAM OF THE GREASE INTERCEPTOR (GI) - 2" INLET/OUTLET MODELS

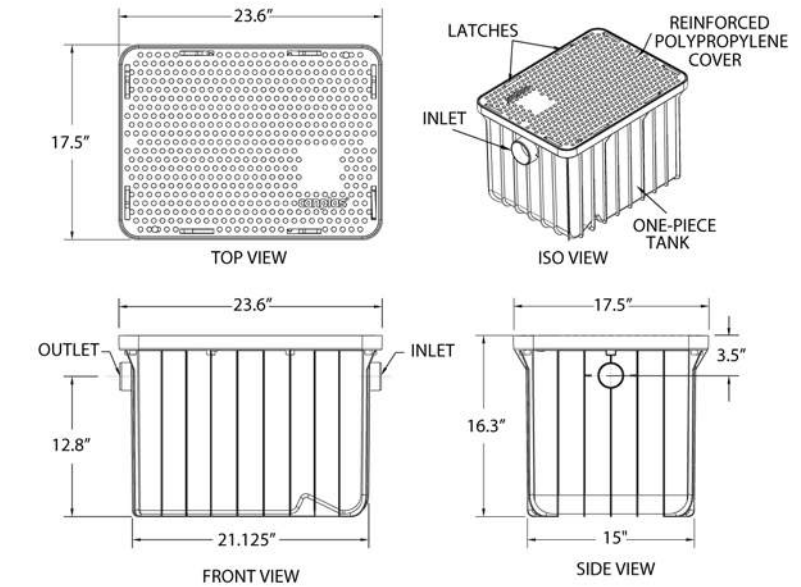
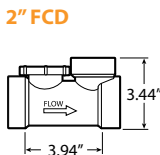

Endura® Lo-PRO Grease Interceptor 25GPM Model

3925A02LO 25GPM (1.6 LPS)

2" (51mm) connection

Notes: ACCESSIBLE FLOW CONTROL DEVICE (FCD) IS SUPPLIED FOR INSTALLATION UPSTREAM OF THE GREASE INTERCEPTOR (GI) - 2" INLET/OUTLET MODEL

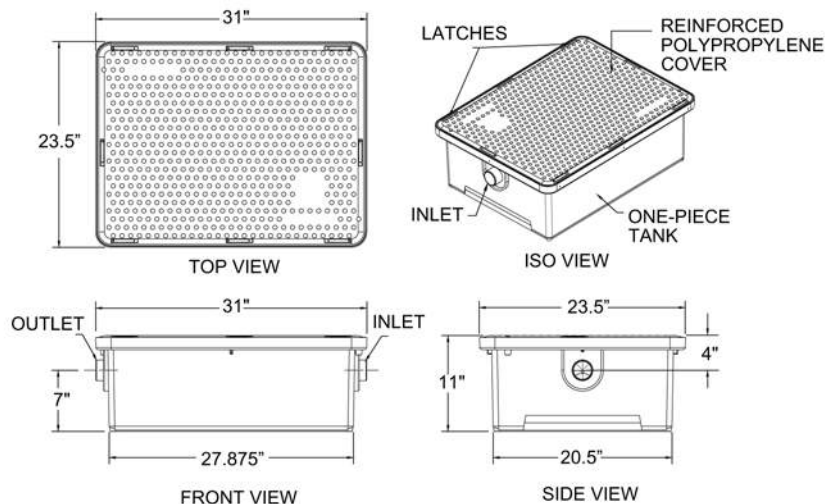
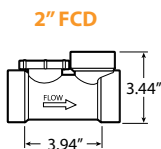

Endura® 25GPM - 35GPM Models

3925ALT02 25GPM (1.6 LPS)
2" (51mm) connection

3925ALT03 25GPM (1.6 LPS)
3" (76mm) connection

3935A03 35GPM (2.2 LPS)
3" (76mm) connection

3935A04 35GPM (2.2 LPS)
4" (110 mm) connection

2" FCD

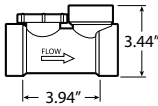

3" FCD

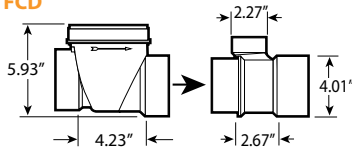

4" FCD

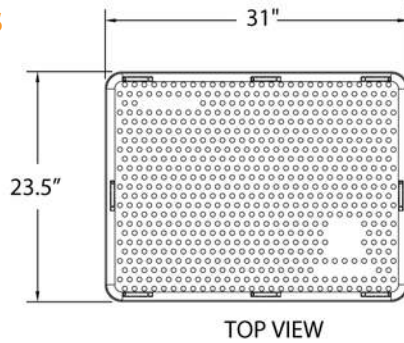
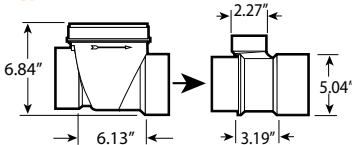

TOP VIEW

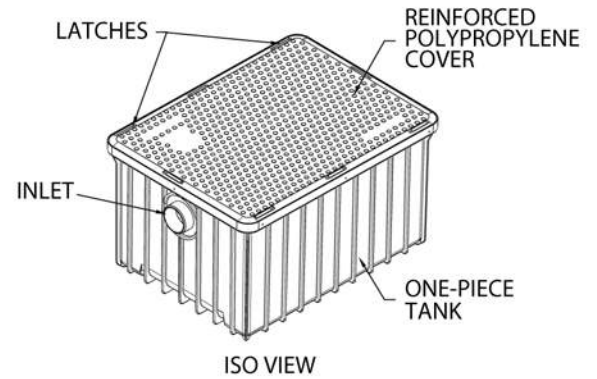

ISO VIEW

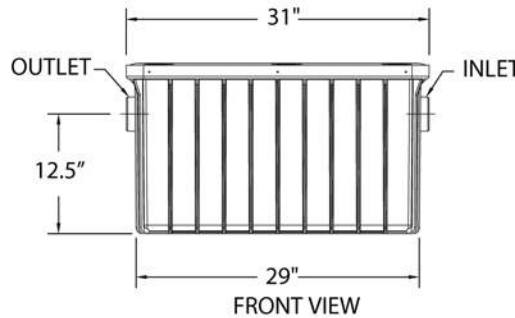

FRONT VIEW

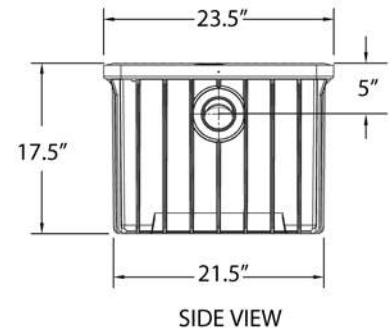

SIDE VIEW

Notes: ACCESSIBLE FLOW CONTROL DEVICE (FCD) IS SUPPLIED FOR INSTALLATION UPSTREAM OF THE GREASE INTERCEPTOR (GI) - 2", 3" or 4" INLET/OUTLET MODELS

Endura® 50GPM Models

3950A03 50GPM (3.2 LPS)
3" (76 mm) connection

3950A04 50GPM (3.2 LPS)
4" (110 mm) connection

Notes: ACCESSIBLE FLOW CONTROL DEVICE (FCD) IS SUPPLIED FOR INSTALLATION UPSTREAM OF THE GREASE INTERCEPTOR (GI) - 3" or 4" INLET/OUTLET MODELS

3" FCD

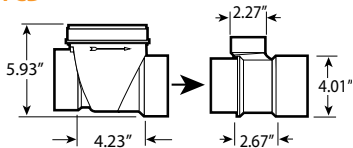

4" FCD

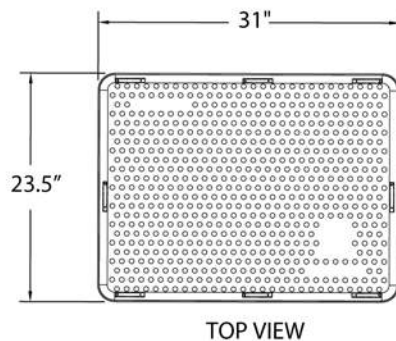
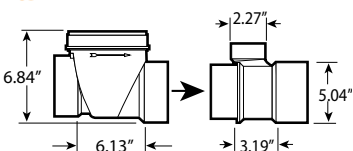

TOP VIEW

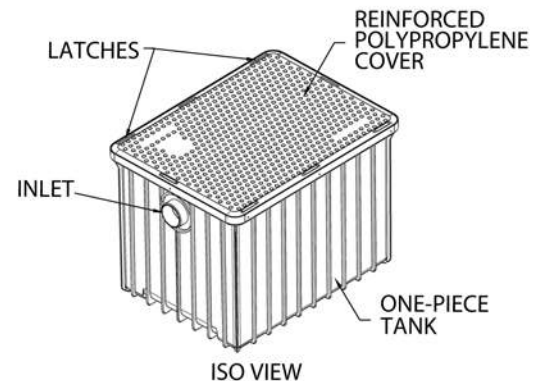

ISO VIEW

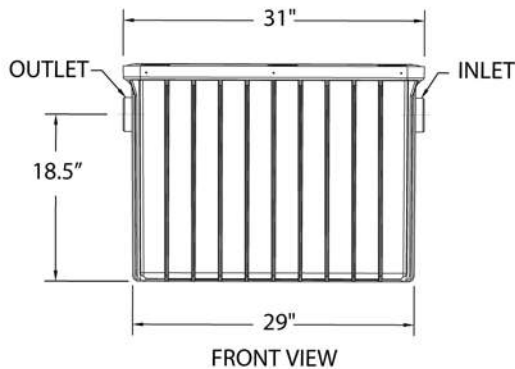

FRONT VIEW

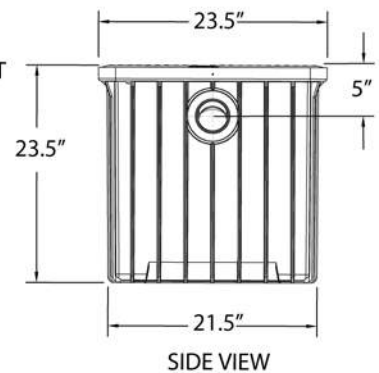

SIDE VIEW

Product	Description	Connection Size	Recycled Content	On-Floor
<p>Endura® XL Grease Interceptor -XL75 – 75GPM 4075A04(T)</p>	<ul style="list-style-type: none"> - 559lb Grease Capacity => 98% Efficiency (NSF ES15741) - Dynamic Inlet Baffle – Internal flow Control (Supplied Standard) - Optional External flow control (PDI G101) - Seamless Tank – Rotationally moulded using up to 100% recompounded material - Dual Access Covers -Traffic Rated (CSA B481.1 Type 'S') Rated in excess of 20,000lb (9072kg) - Airtight/Watertight cover, frame and adjustable riser system - Limited Lifetime Warranty 	Inlet - 4" Sch40 DWV Outlet – 4" Sch40 DWV FTP 4" Optional for Inlet & Outlets Outlet (Side) – 4" SDR35 Sewer	<p>Up to 100%</p>	
<p>Endura® XL Grease Interceptor -XL100 – 100GPM 40100A04(T)</p>	<ul style="list-style-type: none"> - 1058lb Grease Capacity => 98% Efficiency (NSF ES15741) - Dynamic Inlet Baffle – Internal flow Control (Supplied Standard) - Optional external flow control (PDI G101) - Seamless Tank – Rotationally moulded using up to 100% recompounded material - Dual Access Covers -Traffic Rated (CSA B481.1 Type 'S') Rated in excess of 20,000lb (9072kg) - Airtight/Watertight cover, frame and adjustable riser system - Limited Lifetime Warranty 	Inlet - 4" Sch40 DWV Outlet – 4" Sch40 DWV FTP 4" Optional for Inlet & Outlets Outlet (Side) – 4" SDR35 Sewer	<p>Up to 100%</p>	

Dimensions - XL models

Endura® XL 75GPM Models

4075A04
75GPM (4.74 LPS)
4" (110 mm) connection

4075A04T
75GPM (4.74 LPS)
4" (110 mm) threaded connection

Notes: ACCESSIBLE FLOW CONTROL DEVICE (FCD) IS SUPPLIED FOR INSTALLATION UPSTREAM OF THE GREASE INTERCEPTOR (GI)
-4" INLET/OUTLET MODELS

4" External FCD

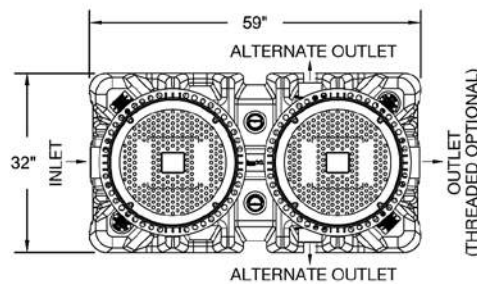
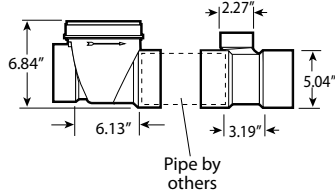

TOP VIEW

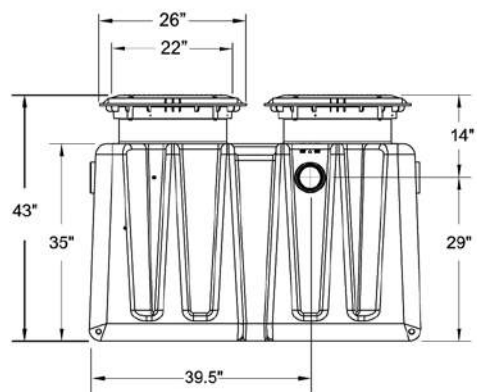



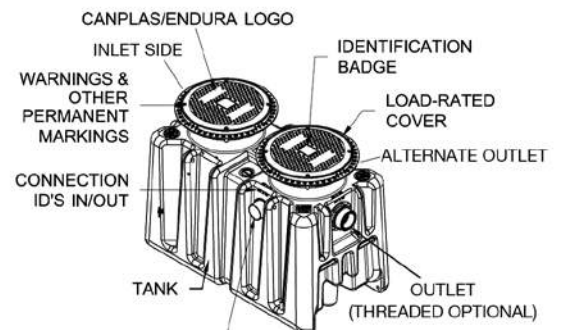



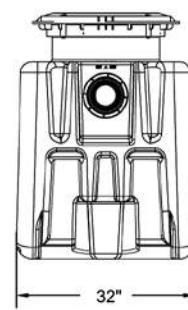

FRONT VIEW

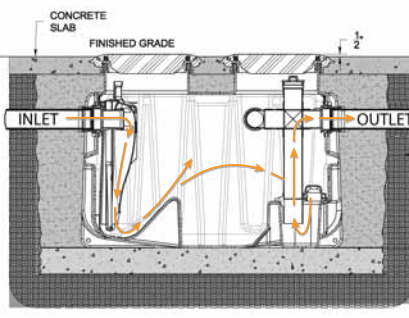

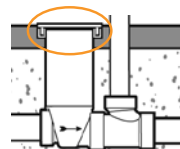
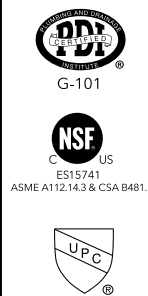
ISO VIEW

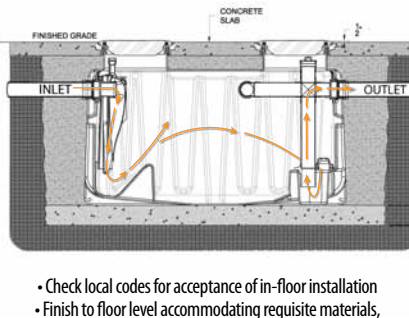

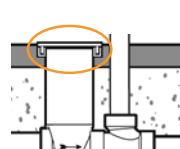
SIDE VIEW

In-Floor	Extension Riser	Flow Control Extension	Standards Conformance	Listings	Thermal Capability	Remarks
 <p>• Check local codes for acceptance of in-floor installation • Finish to floor level accommodating requisite materials, E.G. Tile, mortar, etc.</p>	 <ul style="list-style-type: none"> - 35" 40100AX35 - 18" 40100AX18 - 35" or 18" Cut-to-length Riser Pairs - Max Extension 72" - Full accessories & instructions supplied - Robust, Airtight, Watertight - 100% recompounded riser - Integral guidelines for cutting 	 <p>Sleeve kit for 4" model only, allows access to in-floor flow control device Custom length of 6" Dia. SDR 35 or SDR 28 sewer pipe to be used for access sleeve (Supplied by others) - 4" 392204W</p>	 <p>G-101 NSF C US E515741 ASME A12.14.3 & CSA B481.1 UPC</p>	 <p>Commonwealth of Massachusetts Fox Metro Water Reclamation District</p>	<p>Prolonged intermittent discharge at 71°C (160°F)</p>	<p>3-Part Master Format Specifications, CAD drawings & BIM drawings available at ARCAT.com</p> <p>Installation Guide contact tech-support@endurainterceptor.com</p>
 <p>• Check local codes for acceptance of in-floor installation • Finish to floor level accommodating requisite materials, E.G. Tile, mortar, etc.</p>	 <ul style="list-style-type: none"> - 35" 40100AX35 - 18" 40100AX18 - 35" or 18" Cut-to-length Riser Pairs - Max Extension 72" - Full accessories & instructions supplied - Robust, Airtight, Watertight - 100% recompounded riser - Integral guidelines for cutting 	 <p>Sleeve kit for 4" model only, allows access to in-floor flow control device Custom length of 6" Dia. SDR 35 or SDR 28 sewer pipe to be used for access sleeve (Supplied by others) - 4" 392204W</p>	 <p>G-101 NSF C US E515741 ASME A12.14.3 & CSA B481.1 UPC</p>	 <p>Commonwealth of Massachusetts Fox Metro Water Reclamation District</p>	<p>Prolonged intermittent discharge at 71°C (160°F)</p>	<p>3-Part Master Format Specifications, CAD drawings & BIM drawings available at ARCAT.com</p> <p>Installation Guide contact tech-support@endurainterceptor.com</p>

Endura® XL 100GPM Models

40100A04
100GPM (6.3 LPS)
4" (110 mm) connection

40100A04T
100GPM (6.3 LPS)
4" (110 mm) threaded connection

Notes: ACCESSIBLE FLOW CONTROL DEVICE (FCD) IS SUPPLIED FOR INSTALLATION UPSTREAM OF THE GREASE INTERCEPTOR (GI)
-4" INLET/OUTLET MODELS

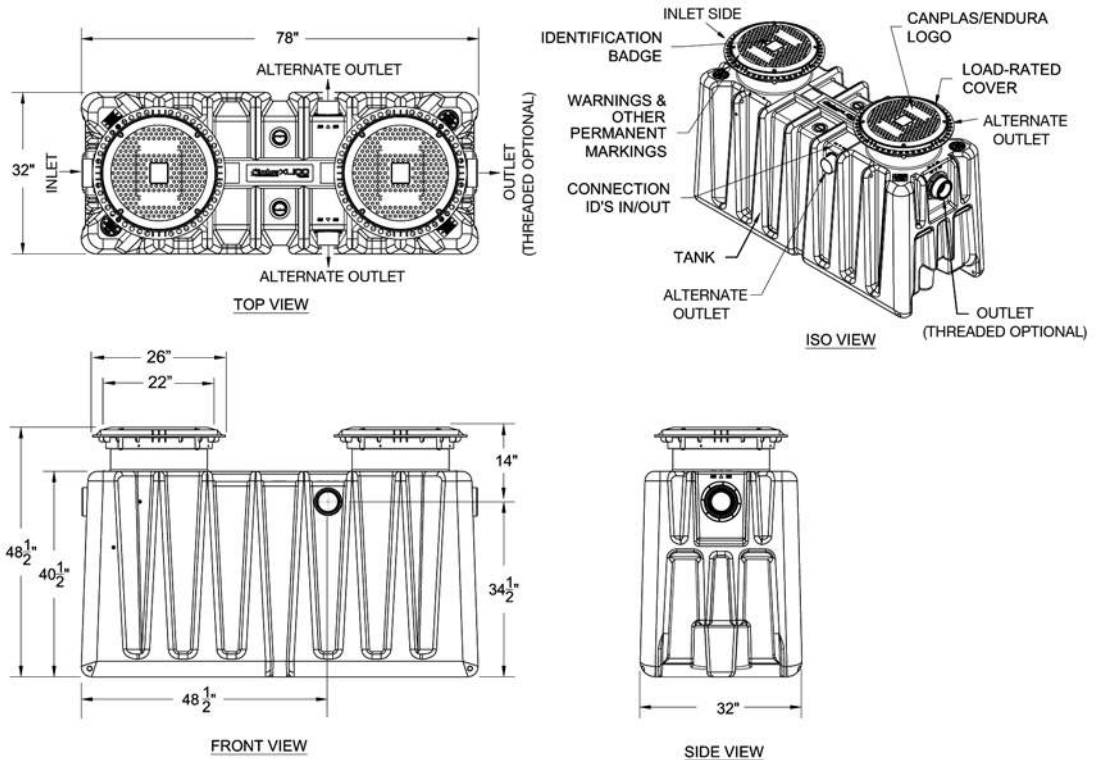
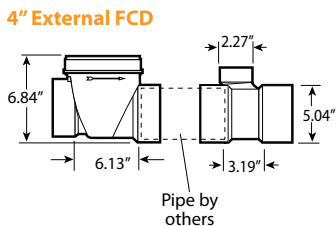

Key Design Considerations

Sizing by Flow Rate

It is recommended that HGI's such as Endura® interceptors are sized by flow rate. The use of a flow control with a Hydromechanical Grease Interceptor is considered **mandatory**. Without a properly sized flow control, the discharge rate through into the interceptor may exceed the design rating of the unit, causing lower efficiencies and increase the risk of grease, passing into the downstream system. Be careful not to confuse liquid capacity and flow rate. Liquid capacity is stated in gallons (or liters) while flow rate is referenced in gallons per minute (GPM) or liters per second (L/Sec).

Fixture Capacity: Most commonly used and recommended method for Hydromechanical Grease Interceptors. This method looks at the maximum capacity of fixtures connected to the interceptor and the time taken to discharge that volume of wastewater through the interceptor. Units are expressed in Gallons Per Minute (gpm).

Calculation takes 75% of maximum capacity of all fixtures and based on a 1 or 2 minute period of time taken to discharge, results in a gallons per minute flow rate. This number is rounded up to the next available size of interceptor, i.e. 16.7gpm become a 20gpm Grease Interceptor.

Table A - Procedure for Sizing Grease Interceptors

STEP	FORMULA	EXAMPLE
1	Determine cubic content of fixture by multiplying length x width x depth	A sink 24" long by 20" wide by 12" deep. Cubic content: 24 x 20 x 12 = 5,760 cu in (61.0 x 50.8 x 30.48 cm ³)
2	Determine capacity in gallons. 1 gallon = 231 cu in	Contents in gallons: 5,760 / 231 = 24.9 gallons (94,451.42 / 1,000 = 94.45 litres)
3	Determine actual drainage load. The fixture is normally filled to approximately 75% of capacity with water as the items being washed displace about 25% of the total fixture content. Actual drainage load = 75% of fixture capacity	Actual drainage load: .75 x 24.9 = 18.7 gallons (0.75 x 94.45 = 70.84 litres)
4	Determine flow rate and drainage period. In general, good practice dictates a one minute drainage period; however, where conditions permit, a two minute drainage period is acceptable. Drainage period is defined as the actual time required to completely drain the fixture. Flow rate = $\frac{\text{Actual Drainage Load}}{\text{Drainage Period}}$	Calculate flow rate for one minute drainage period: 18.7 / 1 = 18.7 g.p.m. flow rate (70.84 / 1 min. = 70.84 l.p.m.) Calculate flow rate for two minute drainage period: 18.7 / 2 = 9.4 g.p.m. flow rate (70.84 / 2 min. = 35.42 l.p.m.)
5	Select Interceptor. From Table B select the interceptor with a flow rating at least equal to the calculated flow rate. When the calculated flow rate falls between two sizes, select the larger of the two interceptors.	For a one minute drainage period: 18.7 g.p.m. (70.84 l.p.m.) flow rate = 20 g.p.m. G.I. For a two minute drainage period: 9.4 g.p.m. (35.42 l.p.m.) flow rate = 10 g.p.m. G.I.

Table B -Metric conversions based on PDI sizes

PDI Size	4	7	10	15	20	25	35	50	75	100
Flow Rate US Gallons per Minute (gpm)	4	7	10	15	20	25	35	50	75	100
Flow Rate Liters per Second (L/Sec)	.25	.44	.63	.95	1.26	1.58	2.20	3.16	4.74	6.3
Grease Capacity Min. (lb)	8	14	20	30	40	50	70	100	150	200
Grease Capacity Min. (kg)	3.63	6.35	9.07	13.61	18.14	22.68	31.75	45.36	68	91

Pipe Size:

Pipe Diameter	Maximum Flow Rate (gpm)	Size of interceptor 1-minute drain period (gpm)	Size of interceptor 2-minute drain period (gpm)
2-inch	20	20	10
3-inch	60	75	35
4-inch	125	150	75



Use our simple online sizing calculator and DFU conversion at...
www.SizeMyGI.net

Sizing by Capacity

Capacity: Based on the volume of wastewater discharge (gallons) into the interceptor expressed as discharge fixture units (DFU's). DFU's are identified in the currently published issue of Uniform Plumbing Code Ch.7 based on occupancy or use.

Fixture	Fixture Units Public	Drainage Fixture Units	Interceptor Volume (min.)		
Floor drain, non-emergency	2	8	500		
Special purpose sink w/1-1/2" trap	3				
Special purpose sink w/2" trap	4				
Special purpose sink w/3" trap	6				
Commercial sink w/food waste w/1-1/2" trap	3				
Bar Sink	2				
Mop Sink	3				
Laundry Sink	2				
				21	750
				35	1000
		90	1250		
		172	1500		
		216	2000		

Example: Commercial sink with food waste with 1-1/2" trap, plus mop sink and special purpose sink 2" trap.

3+3+3=9 (DFU)

Referencing table below 9 DFU will require 750 gallon min. interceptor volume.

Floor Drains & Floor Sinks: Take the volume of water produced by the number of hose bibs (ie 1.5-2.0 gpm per 3/4" faucet)

Note: Capacity sizing is typically applied to gravity grease interceptors (GGI) resulting in a liquid capacity that is substantially greater than an equivalent hydromechanical GI. **An HGI due to its qualified efficiency and grease capacity at breakdown (when efficiency falls below 90%) results in actual grease capacity that is operationally equivalent to a GGI that is 5-6 times that of the HGI.**

How can I convert DFU to GPM?

The conversion of DFU (Discharge Fixture Units) to Flow Rate equivalent is not directly achievable by application of a standard formula. As an experienced manufacturer in the Grease Management market, we have been able to identify and validate a method of conversion that references accepted engineering data and applies the following approach. This method is offered as a **manufacturers recommended method of conversion** to determine Hydromechanical Grease Interceptor equivalency, to a respective Gravity Grease Interceptor volume where initially determined by total calculated DFU discharge.

Step 1: Determine the total DFU discharge by following applicable code-defined methods and using UPC Table 1014.3.6 as a basis. The total DFU is used to identify the respective Gravity Interceptor volume (US Gallons).

Step 2: Multiply the selected volume by 2 (Equivalency Factor) and divide the result by 30 (min). 30 minutes is the typical retention time used as the basis of design for Gravity Grease Interceptor (GGI) volume.

Example: At 50DFU discharge, a 1250 gallon Gravity Grease Interceptor (GGI) is identified by the table. Therefore, 1250 (USG) x2 (Equivalency Factor) = 2500USG. Now divide the 2500gallons by the 30 minute retention time and the output is 83.3GPM. Using established practice, this number is rounded up to the next standard size of interceptor available and so conversion of a 1250USG Gravity Grease Interceptor is considered to be a 100GPM Hydromechanical GI.

Technical Data

• Part Number	3907A02	3910A02	3915A02C	3920A02	3925A02L0	3925ALT02 (2") 3925ALT03 (3")	3935A03 (3") 3935A04 (4")	3950A03 (3") 3950A04 (4")	4075A04	40100A04
US Gallons Per Minute - GPM (L/Sec)	7 (0.44)	10 (0.63)	15 (0.94)	20 (1.26)	25 L0 (1.6)	25 (1.6)	35 (2.2)	50 (3.2)	75 (4.74)	100 (6.3)
Grease Capacity Min - lb (kg)	14 (6.35)	20 (9.07)	30 (13.6)	40 (18.1)	50 (22.68)	50 (22.68)	70 (31.8)	100 (45.4)	150 (68.2)	200 (90.8)
Average Efficiency % (ASME A112.14.3)	95.5%	92.5%	92.0%	95.4%	97.1%	98%	98.6%	93.9%	=>98%	=>98%
Grease Capacity Actual (ASME A112.14.3) - lb (kg) † NSF E515741	31.95 (14.49)	38.07 (17.28)	40.97 (18.58)	76.4 (34.65)	53.4 (24.22)	56.25 (25.51) *	138.5 (62.8)	122.07 (55.3)*	559 (253)†	1058 (480)†
Operating Temperature Capabilities	220°F (104°C)	220°F (104°C)	220°F (104°C)	220°F (104°C)	220°F (104°C)	220°F (104°C)	220°F (104°C)	220°F (104°C)	160°F (71°C)	160°F (71°C)
Surface Load Capacity	440 lb (200 kg)	440 lb (200 kg)	440 lb (200 kg)	440 lb (200 kg)	440 lb (200 kg)	440 lb (200 kg)	440 lb (200 kg)	440 lb (200 kg)	20,000 lb (9072 kg)	20,000 lb (9072 kg)
Unit Weight (Empty)	15.8 lb (7.17 kg)	15.8 lb (7.17 kg)	15.8 lb (7.17 kg)	23 lb (10.4 kg)	23.9 lb (10.85 kg)	45 lb (20.4 kg)	45 lb (20.4 kg)	60 lb (27.2 kg)	233 lb (106 kg)	283 lb (128 kg)
Liquid Capacity	12.96 gal (49.06 L)	12.96 gal (49.06 L)	12.96 gal (49.06 L)	21.6 gal (81.8 L)	18.9 gal (71.54L)	39.4 gal (149.1 L)	39.4 gal (149.1 L)	52.0 gal (197 L)	158 gal (598 L)	257 gal (973 L)
Connection size (mechanical joint only)	2"	2"	2"	2"	2"	2" (3925ALT02) 3" (3925ALT03)	3" (3935A03) 4" (3935A04)	3" (3950A03) 4" (3950A04)	4"	4"

* Not evaluated to breakdown capacity (PDI-G101)

Grease Capacity Min - lb (kg): Industry minimum grease capacity based on GPM flow rate. Requires minimum 2 lb of grease capacity for each GPM of flow.

Grease Capacity Actual - lb (kg): Actual capacity at breakdown when tested to ASME A112.14.3 / NSF E515741 as indicated.

Dimensions - Flow Control Device Assembly



1 Piece Compact Flow Control



2 Piece Flow Controls (3" Version Illustrated)

AIR INTAKE TEE
on XL models 4" h x h

Flow Control & Air Intake Combined	
Connection Iron Pipe Size (Solvent weld)	Compact 2" h x h
A	3.94" (100mm)
B	3.44" (87.4mm)
C	-

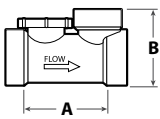

Connection Iron Pipe Size (Solvent weld)	Flow Control Body			Air Intake Tee		
	2" h x h	3" h x h	4" h x h	3" spg x h	4" spg x h	XL Models 4" h x h
A	3" (76.2mm)	4.23" (107.4mm)	6.13" (155.7mm)	2.67" (67.8mm)	3.19" (81mm)	3.19" (81mm)
B	3.84" (97.5mm)	5.93" (151mm)	6.84" (173.7mm)	4.01" (101.9mm)	5.04" (128mm)	5.04" (128mm)
C	-	-	-	2.27" (57.7mm)	2.72" (69.1mm)	2.72" (69.1mm)

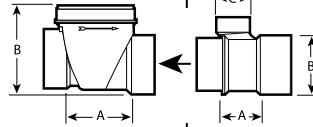

Flow Control

Key to hydromechanical function and performance is flow control. If designing for compliance with PDI-G101 an external flow control(s) SHALL be required as part of the design and installation. Where acceptable to the Authority Having Jurisdiction, internal means of flow control can be employed providing that the interceptor is approved to the currently published version of ASME A112.14.3 -Type C or D. Any method of flow control SHALL be accessible once in operation for cleaning and maintenance purposes. The Endura® external flow control device can be recessed into the floor if required. Extension sleeves available. (See Page 5)

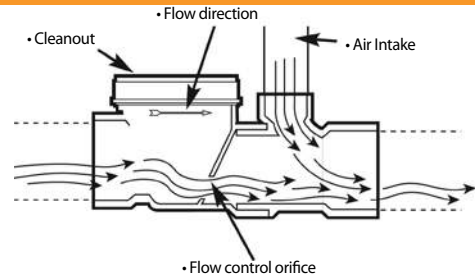

Flow Control Location – Indirect Connection:



Where required to be installed as an indirect plumbing system, the initial means of flow control SHALL be installed upstream of the air gap to prevent overflow during fixture/appliance discharge.

Some local jurisdictions require warewashing installations to be made on an indirect basis incorporating an air gap.

An air gap prevents back up of contaminated water into the sinks/appliances in the event of a system back flow. The flow control device must be incorporated before the indirect connection to prevent overflow during high/maximum waste water discharge. If an air gap is located within 6" of flow control device*, installation of the air intake tee is optimal. (*Verify with Authority Having Jurisdiction)

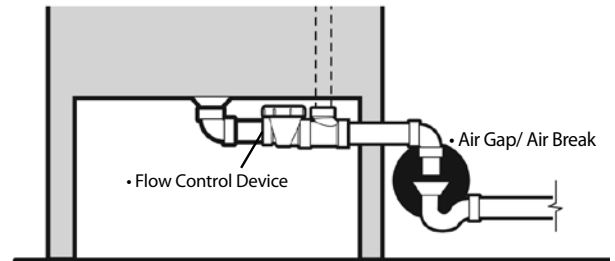

Flow Control Formats

External (Supplied Standard up to 50gpm)

Hub x Hub format – Sch40 DWV. Nominal diameters 2" (Compact), 3" and 4". For solvent weld within ABS or PVC DWV drainage systems, use appropriately approved solvent cement.



NOTE: The Flow Control cannot be solvent welded directly to the interceptor. An appropriately sized pipe stub will be necessary in the event that the FCD is in close proximity to the interceptor, allowing connection only with locally approved Mechanical Joint (MJ) couplings.

Spigot (Suffix 'S')

Supplied with Spigot format connections for installation with locally approved Mechanical Joint (MJ) couplings.

Threaded (Suffix 'T')

Supplied with Female Pipe Thread (FPT) connections. Installed to Male Pipe Thread (MPT) using appropriate (PTFE) thread sealing tape.

Internal (Supplied Standard 75/100gpm)

On models 4075A04(T) and 40100A04(T) the internal flow control is located inside the dynamic inlet baffle, affixed to the downstream part that moves forward when the baffle is opened. This maintains full accessibility when operational. NOTE: Internal flow control plate will only be removed when replaced with an external equivalent of the correct flow rate. Floor below installation can use the internal flow control as the secondary flow control, the primary flow control being installed externally as close as possible to fixtures.



Compact Version
Example: 3922125C
1 piece format

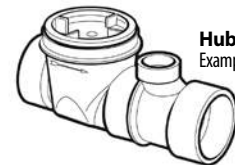

Hub Version
Example: 3933125
2 piece format
- 3" & 4" models
(2" available)



Spigot Version
Example: 3933125AS
2 piece format
- 3" & 4" models
(2" available)

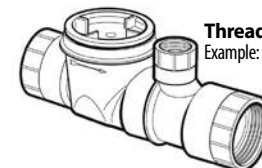

Threaded Version
Example: 3933125AT
2 piece format
- 3" & 4" models
(2" available)

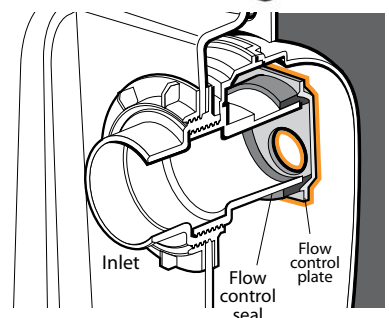

Tank Connections

All Endura® Grease Interceptors are manufactured with standard no hub connections to accept locally approved/accepted MJ (Mechanical Joint) couplings.

This method allows resilience in the connections to prevent stress and a flexible means of integrating metallic or plastic plumbing systems. Should adaption of pipe connection be required, use appropriate mechanical joint reducers but do not allow decrease pipe diameter across the unit. (i.e. 3" inlet, 2" outlet.)

Due to regional and local code variation, models with threaded connections (FPT) are available by adding suffix 'T' to the part number. Both tank and flow control (TFCD) will be supplied with FPT connections in this instance based on the respective nominal pipe size. Likewise Endura® Interceptors can be supplied with spigot format flow controls (SFCD) by adding suffix 'S' to the part number.

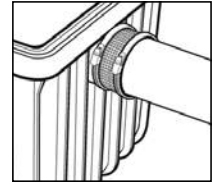
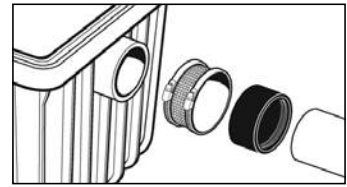

Note: Solvent cement is not an acceptable jointing method from the piping system to the interceptor. This will result in leakage.

Connection of Dishwashing Systems

Dependent on the Authority Having Jurisdiction (AHJ), a dishwashing system may be required or prohibited from discharging to the grease interceptor. Verify with the respective AHJ. Best practice recommends that where a dishwashing system is required to be connected to the interceptor, that it be serviced by a separate and appropriately sized interceptor, the outlet being connected to the building drain downstream of the main interceptor.

Where not specified, the dishwashing system is recommended to bypass the grease interceptor, the outlet being connected downstream of the interceptor outlet. This is based evidentially on the negative impact of commercial detergents and surfactants that are specifically designed to emulsify fats oil and grease making it virtually impossible to separate this material from waste water discharge. If discharged to the interceptor, the same agents will likewise cause even the most efficient interceptor, regardless of generic type to work at a significantly reduced efficiency, passing FOG to the downstream system.

Air-Balanced Operation

A hydromechanical grease interceptor is designed to operate as an air balanced environment. This is vital to the function of the interceptor and as such no modification or removal of any component parts should be made before, during or after installation unless specifically addressed in the respective Installation & Operation document.

Venting

Unlike Gravity Grease Interceptors, a Hydromechanical Grease Interceptor tank is not required to be directly vented. This would be detrimental to the function of the interceptor. All connected appliances shall be individually trapped and vented in accordance with local code requirements. The downstream drain carrying effluent to the municipal wastewater system shall also be vented to atmosphere in compliance with applicable code.

Drain Cleanouts

For installations below grade, most codes require the installation of a two way cleanout immediately before and after the respective inlet and outlet connections. These cleanouts will be extended to grade so as to remain accessible once the interceptor is operational.

Head Effect

An installation above or below grade that sees a fall equal to or in excess of 8 ft, when measured from the outlet of the highest appliance to the invert of the interceptor SHALL require the installation of a secondary flow control device to neutralize the effect of head pressure. The first flow control will be located as close as possible to the last appliance discharging to the interceptor, the second being located externally immediately before the interceptor or by utilizing the manufacturers internal flow control device where available. See page 17/18 for reference.

Accessibility for Maintenance:

All grease interceptors regardless of generic type, require regular maintenance. Any design and subsequent installation shall make due consideration to the provision of access for the same as defined in the respective installation documentation. Installation documents are supplied with every interceptor. Copies are also available by contacting: tech-support@endurainterceptor.com

Typical Installation

• On Floor

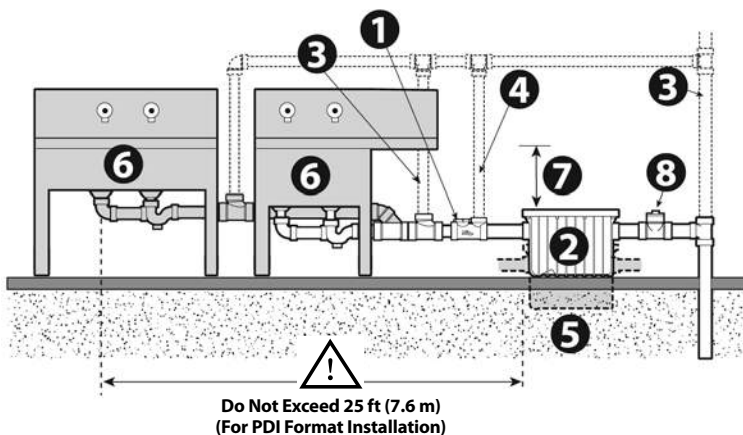

CAUTION: CLEARANCE REQUIRED

15" clearance (21" for 50GPM model) to remove the baffles for cleaning and maintenance.

- 1 • Flow Control Device
- 2 • Grease Interceptor
- 3 • Vented Waste
- 4 • Air Intake
- 5 • Semi Recessed Option
- 6 • Sink
- 7 • ⚠ Minimum Clearance 15" / 21"
- 8 • Cleanout required in most jurisdictions

• In Floor

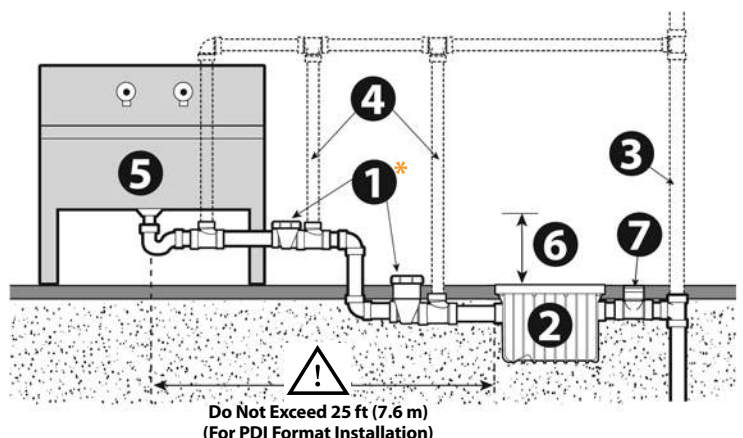

When backfilling in-floor, the interceptor must have both the cover fitted and be filled with water to the inlet/outlet level.

This will ensure the tank itself will not move during backfilling, pouring and/or floor finishing. When backfilling in particular, care should be taken to do so evenly around the unit and with light manual pressure only.



Ensure that the interceptor is clearly identified to flooring contractors to prevent it from being covered with flooring material. Taping cardboard to the cover is generally effective.



CAUTION: CLEARANCE REQUIRED

15" clearance (21" for 50GPM model) above the grease interceptor is required to remove the baffles for cleaning and maintenance.

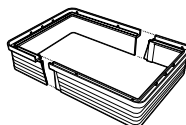

6" Modular risers available where deeper installation is necessary to accommodate existing drainage.

- Stackable up to 3 sets (18" Total)
- 3920AX6 (20/25gpm) and 3935AX6 (35/50gpm)

- 1 • Flow Control Device
- 2 • Grease Interceptor
- 3 • Vented Waste
- 4 • Air Intake
- 5 • Sink
- 6 • ⚠ Minimum Clearance 15" / 21"
- 7 • Cleanout required in most jurisdictions

• In Floor - Extended Capacity

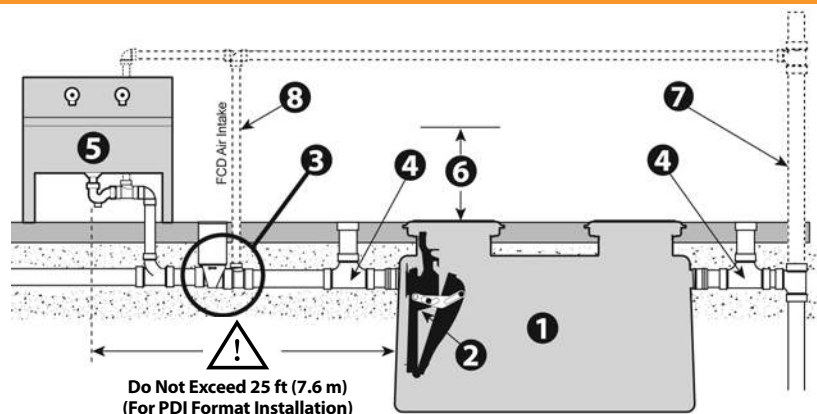

When backfilling in-floor, the interceptor must have both the cover fitted and be filled with water to the inlet/outlet level. This will ensure the tank itself will not move during backfilling, pouring and/or floor finishing. When backfilling in particular, care should be taken to do so evenly around the unit and with light manual pressure only.



Ensure that the interceptor is clearly identified to flooring contractors to prevent it from being covered with flooring material. Taping cardboard to the cover is generally effective.



CAUTION: CLEARANCE REQUIRED

Locate the interceptor so as to allow for accessibility when conducting maintenance and regular cleaning. Set the interceptor on a firm, level surface ensuring tank is equally supported.

Risers available where deeper installation is necessary to accommodate existing drainage.

- 35" or 18" Cut-to-length Riser Pair - Max Extension 72"
- Full accessories & instructions supplied
- Robust, Airtight, Watertight
- 100% recomounded riser, Integral guidelines for cutting
- PN: 35" - 40100AX35 / 18" - 40100AX18



- 1 • XL Grease Interceptor
- 2 • Internal Flow Control and Baffle
- 3 • External Flow Control (Optional) required for PDI installations
- 4 • Cleanout (recommended)
- 5 • Sink
- 6 • ⚠ CAUTION: CLEARANCE REQUIRED
- 7 • Vented Waste
- 8 • Air Intake

Low Profile

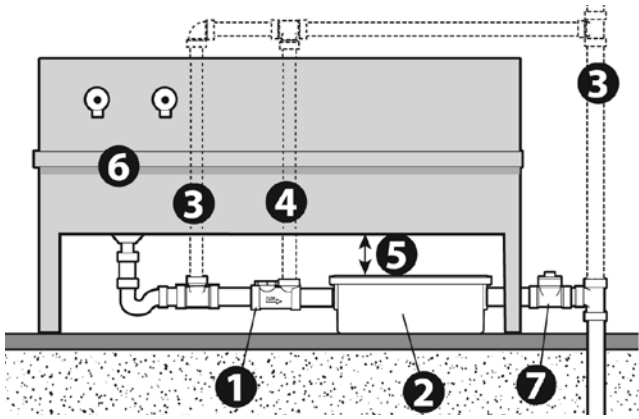

The Endura® Lo-PRO is installed on floor. Ensure you design/locate the grease interceptor so as to allow for maintenance. Placement should allow the cover to be easily removed for cleaning. **A minimum clearance of only 6 inches is required above the top of the Grease Interceptor to allow removal of the internal baffles for a complete cleanout.**



CAUTION: CLEARANCE REQUIRED

6" clearance above the grease interceptor required to remove the baffles for cleaning and maintenance.

- 1 • Flow Control Device
- 2 • Grease Interceptor
- 3 • Vented Waste
- 4 • Air Intake
- 5 • ⚠ Minimum Clearance 6"
- 6 • Sink
- 7 • Cleanout required in most jurisdictions

• Floor Below - Multiple Fixture Installation

Typical Installation

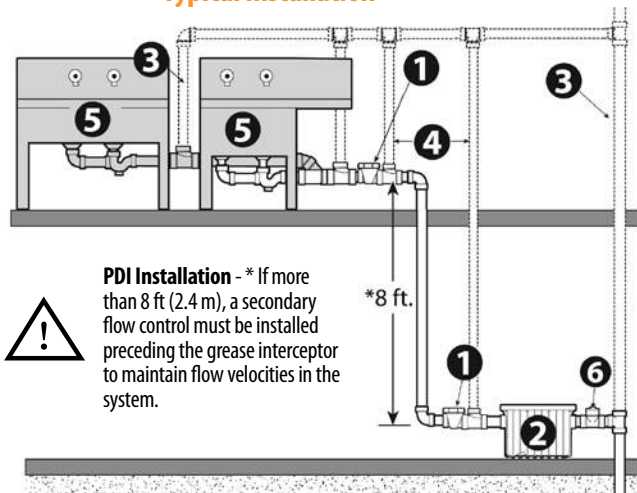

PDI Installation - * If more than 8 ft (2.4 m), a secondary flow control must be installed preceding the grease interceptor to maintain flow velocities in the system.

Ontario Can. Plumbing Code 7.4.4.3 (9) Typical Installation

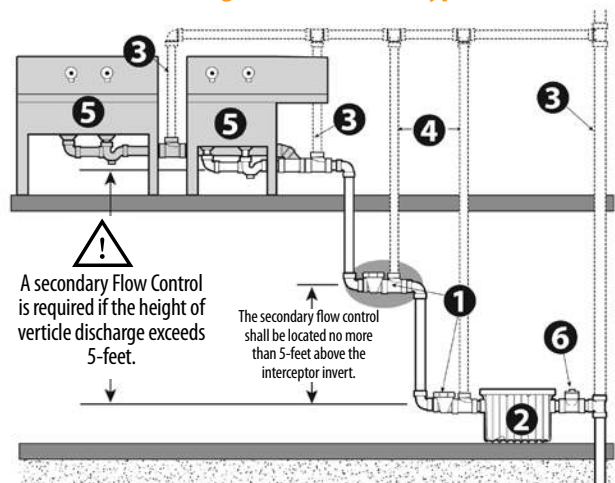

One interceptor serving multiple fixtures is recommended only when the fixtures are located close together (max 25 ft of developed pipe run). In such installations, each fixture should be individually trapped and back-vented.

- 1 • Flow Control Device
- 2 • Grease Interceptor
- 3 • Vented Waste
- 4 • Air Intake
- 5 • Sink
- 6 • Cleanout required in most jurisdictions

• Floor Below - Extended Capacity, Multiple Fixture Installation

Typical Installation

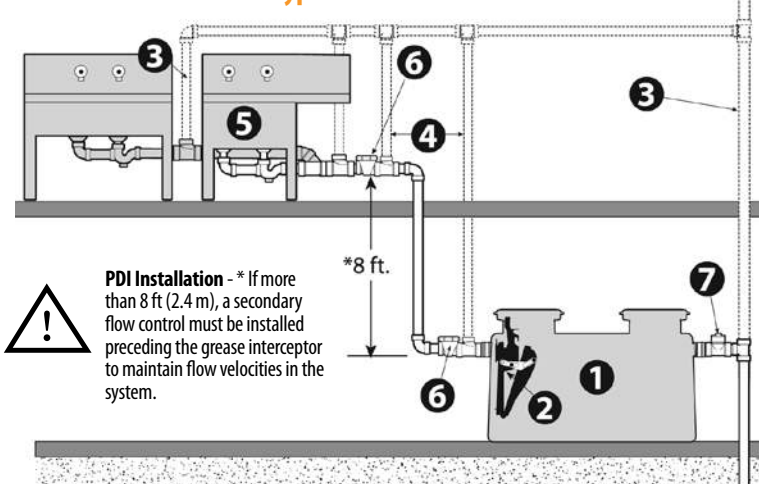

PDI Installation - * If more than 8 ft (2.4 m), a secondary flow control must be installed preceding the grease interceptor to maintain flow velocities in the system.

Ontario Can. Plumbing Code 7.4.4.3 (9) Typical Installation

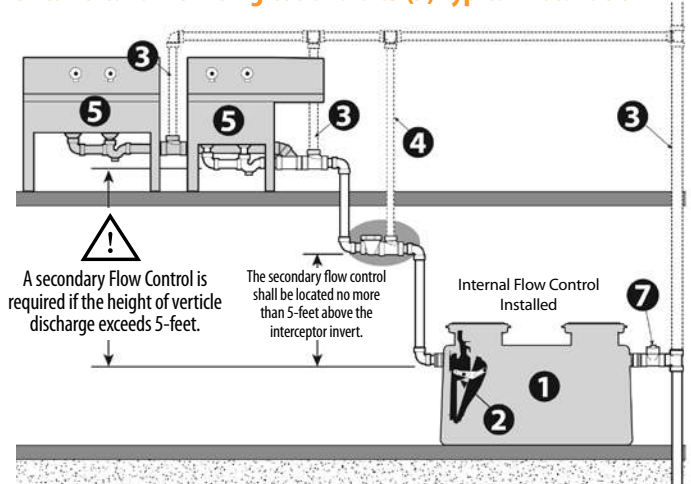

One interceptor serving multiple fixtures is recommended only when the fixtures are located close together (max 25 ft of developed pipe run). In such installations, each fixture should be individually trapped and back-vented.

- 1 • XL Grease Interceptor
- 2 • Internal Flow Control and Baffle
- 3 • Vented Waste
- 4 • Air Intake
- 5 • Sink
- 6 • External Flow Control (Optional) required for PDI installations (No internal flow control installed)
- 7 • Cleanout required in most jurisdictions

• In Floor Alternate

• Fork Lift, Pump Truck Traffic Area

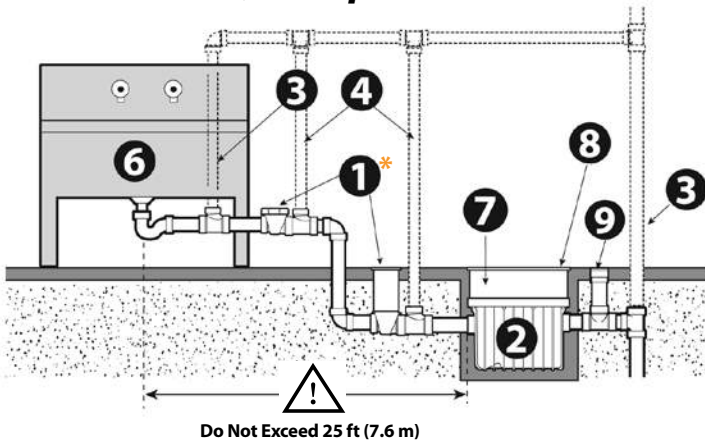

Provision of a concrete pit with a load rated access cover will be required where pump trucks or fork lifts travel.

- 1 • Flow Control Device
* Above grade installation preferred
- 2 • Grease Interceptor
- 3 • Vented Waste
- 4 • Air Intake
- 5 • Hanger (Supplier by installer)
- 6 • Sink
- 7 • Concrete pit
- 8 • Load Rated Access Cover (supplied by others)
- 9 • Cleanout required in most jurisdictions

Note: XL Extended Capacity Models

Endura®XL models are manufactured with Load Rated covers. See page 17 for installation notes.

• Suspended

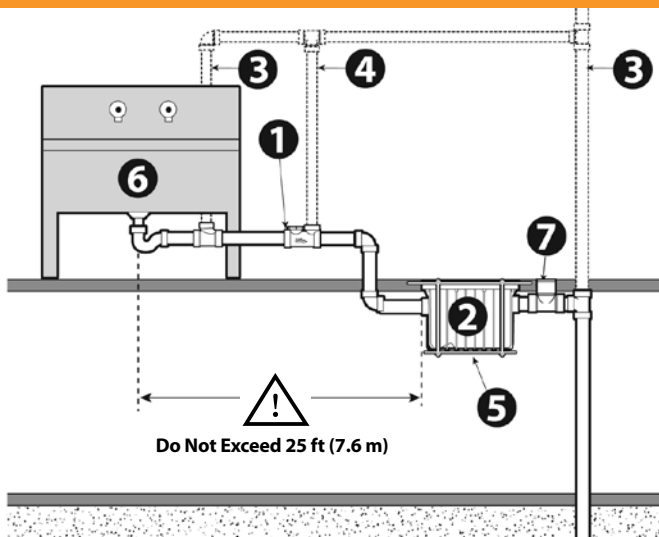

Due to the degree of risk and potential liability for the installer, great care must be taken in designing a hanger system. We recommend consulting an engineer before installing in this manner.

- 1 • Flow Control Device
- 2 • Grease Interceptor
- 3 • Vented Waste
- 4 • Air Intake
- 5 • Hanger (Supplied by installer, designed by licensed engineer)
- 6 • Sink
- 7 • Cleanout required in most jurisdictions



Hanger must accommodate min. 541 lb (246kg) Safety factor of 2.5 is recommended.

• Suspended - Extended Capacity

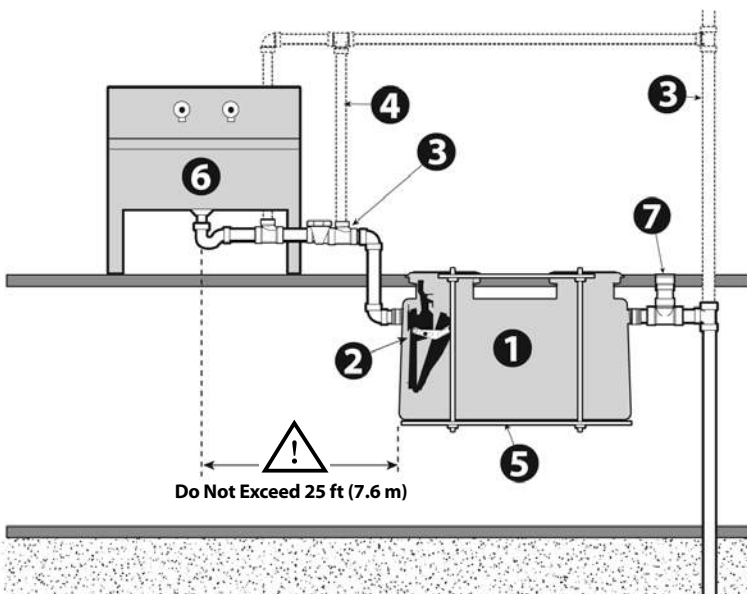

Due to the degree of risk and potential liability for the installer, great care must be taken in designing a hanger system. We recommend consulting an engineer before installing in this manner.

- 1 • XL Grease Interceptor
- 2 • Internal Flow Control and Baffle
- 3 • External Flow Control required for PDI installations
- 4 • Air Intake
- 5 • Hanger (Supplied by installer)
- 6 • Sink
- 7 • Cleanout required in most jurisdictions



When full the weight of the tank is significant XL75 Approx. 1300lb [590kg], XL100 Approx. 2150lb [975kg]

Safety factor of 2.5 is recommended. For suspended application engineering service by a qualified engineer will be necessary.

• Interior or Exterior Below Grade Installations - Extended Capacity

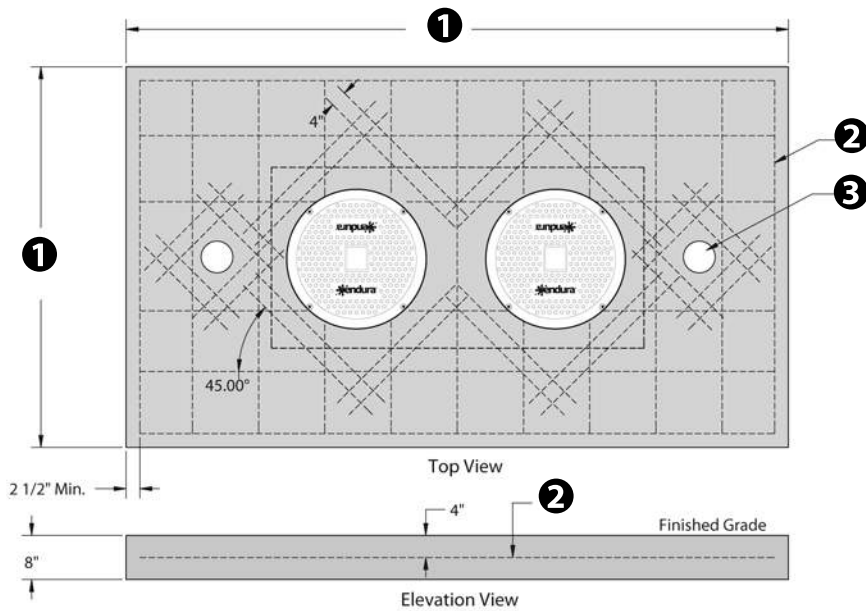

• Concrete Slab Detail For Traffic Loading

Concrete to be 28 day compressive strength to 4000 PSI. Reinforcement with No.4 rebar (1/2") grade 60 steel per ASTM A615; connected with tie wire. Rebar to be 2 1/2" from edge of concrete. Rebar spacing 12" grid. 4" spacing around access openings.

- ① • Concrete Pad must extend min. 18" outside the unit footprint
- ② • No.4 rebar (1/2")
- ③ • 2-Way cleanout tee (414155BC)

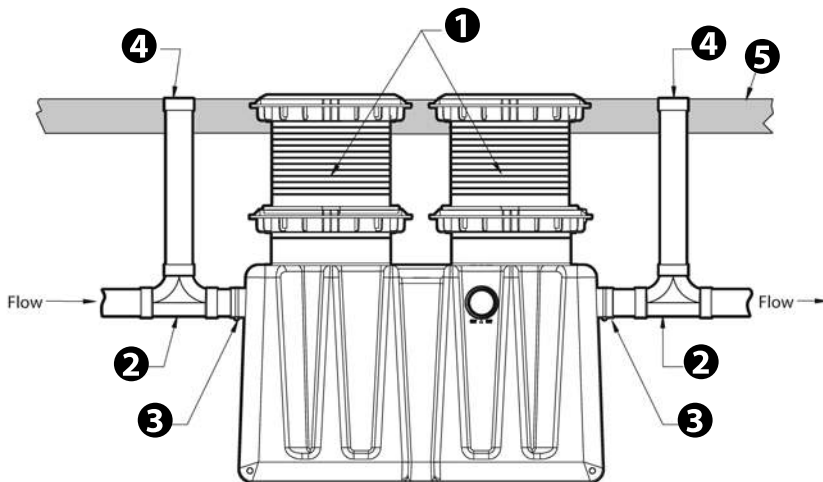

• Side View Detail For unit details see specification sheet for selected unit

- ① • Risers to grade
- ② • 2-Way cleanout tee (414155BC)
- ③ • Standard 4" mechanical joint coupling (by others)
- ④ • Clean out to grade on outlet pipe of each unit (by others)
- ⑤ • Concrete Slab

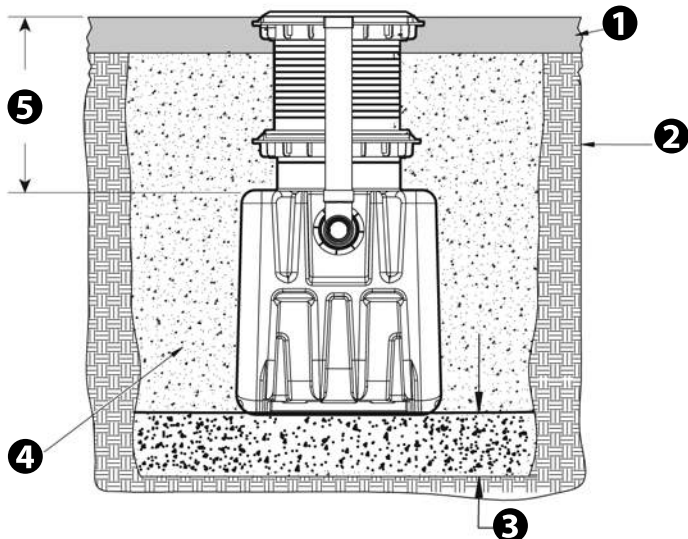

• Excavation and Backfill Detail

- ① • Concrete Slab
- ② • Native soil
- ③ • 6" Min. base crushed aggregate material approx. 3/4" size rock, pea gravel or sand 95 proctor.
- ④ • Crushed aggregate material approximately 3/4" size rock, pea gravel or sand.
- ⑤  • 72" Maximum height

• Multi-Unit Installations - Extended Capacity

2 no. XL75 – PARALLEL
Up to 150GPM, 1118 lbs
Grease Capacity.



2 no. XL100 – PARALLEL
Up to 200GPM, 2116 lbs
Grease Capacity.

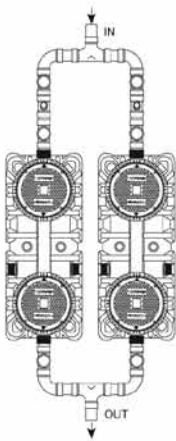

3 no. XL100 – PARALLEL
Up to 300GPM, 3174 lbs
Grease Capacity.

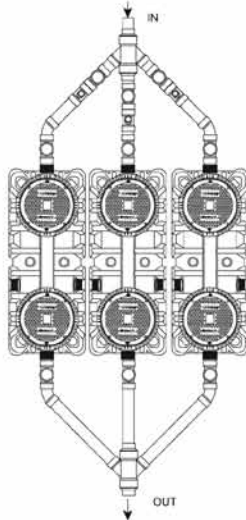

4 no. XL100 – PARALLEL
Up to 400GPM, 4232 lbs
Grease Capacity.

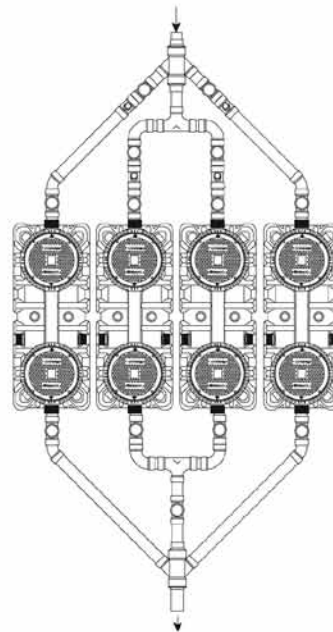

Parallel Installation:

- Parallel configurations shown are considered optimal for application and should be followed.
- Intended for installations with high flow (greater than 60% of rated flow capacity) per unit.

2 no. XL75 – SERIES - 75GPM, 1118 lbs Grease Capacity.

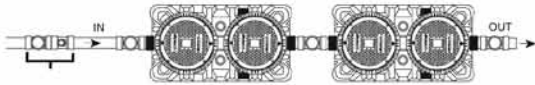

2 no. XL100 – SERIES - 100GPM, 2116 lbs Grease Capacity.



3 no. XL100 – SERIES - 100GPM, 3174 lbs Grease Capacity.

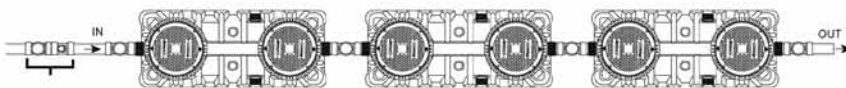

4 no. XL100 – PARALLEL - Up to 400GPM, 4232 lbs Grease Capacity.



4 no. XL100 – PARALLEL - Up to 400GPM, 4232 lbs Grease Capacity.

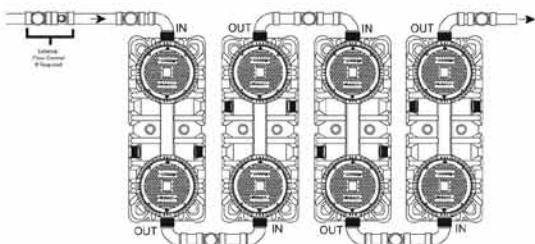

Series Installation:

- Series configurations shown are considered optimal for application and should be followed
- Anticipated as installations with low to medium flow (less than 60% of rated flow capacity)

Specifications

Endura® brand products are manufactured by Canplas Industries Ltd

SECTION 22 13 23 GREASE INTERCEPTORS

Copyright 2014 - 2016 ARCAT, Inc. - All rights reserved

PART 1 GENERAL

1.1 SECTION INCLUDES

- A. Grease interceptors (Hydromechanical).

1.2 RELATED SECTIONS

- A. Section 22 13 00 – Facility Sanitary Sewerage.

1.3 REFERENCES

- A. CAN/CSA-B481.1: Testing and Rating of Grease Interceptors using Lard.
- B. PDI G101: Testing and Rating Procedure for Hydromechanical Grease Interceptors.
- C. ASME A112.14.3: Grease Interceptors.

1.4 SUBMITTALS

- A. Submit under provisions of Section 01 30 00 - Administrative Requirements.
- B. Product Data: Manufacturer's data sheets on each product to be used, including:
 - 1. Preparation instructions and recommendations.
 - 2. Storage and handling requirements and recommendations.
 - 3. Installation methods.

1.5 QUALITY ASSURANCE

- A. Manufacturer Qualifications: Minimum five (5) years of experience manufacturing similar products.
- B. Installer Qualifications: Minimum two (2) years of experience installing similar products.

1.6 PRE-INSTALLATION MEETINGS

- A. Convene minimum two weeks prior to starting Work of this section.

1.7 DELIVERY, STORAGE, AND HANDLING

- A. Deliver and store products in manufacturer's unopened packaging bearing the brand name and manufacturer's identification until ready for installation.
- B. Handling: Handle materials to avoid damage.

1.8 PROJECT CONDITIONS

- A. Maintain environmental conditions (temperature, humidity, and ventilation) within limits recommended by manufacturer for optimum results. Do not install products under environmental conditions outside manufacturer's recommended limits.

1.9 SEQUENCING

- A. Ensure that products of this section are supplied to affected trades in time to prevent interruption of construction progress.

1.10 WARRANTY

- A. Endura® Grease Interceptors (7-50 GPM) and Solids Interceptor products as manufactured by Canplas Industries Ltd shall be supported by a 10 year manufacturer's extended warranty.
- B. Endura®XL Grease Interceptors as manufactured by Canplas Industries Ltd shall be supported by a manufacturer's limited lifetime warranty.

PART 2 PRODUCTS

2.1 MANUFACTURERS

- A. Acceptable Manufacturer: Canplas Industries Ltd., which is located at: ; Canada; 500 Veterans Dr. P.O. Box 1800; Barrie, ON, Canada L4M 4V3; Toll Free Tel: 800-461-1771; Tel: 705-726-3361; Fax: 705-726-2186; Email: tech-support@endurainterceptor.com;
- B. Substitutions: Not permitted.
- C. Requests for substitutions will be considered in accordance with provisions of Section 01 60 00 - Product Requirements.

2.2 GREASE MANAGEMENT

- A. Endura® Grease Interceptors and Solids Interceptor products shall be from a single source of manufacture, Canplas Industries Ltd. These products may be offered nationally, regionally or locally by wholesale or retail distributors.

2.3 GREASE INTERCEPTORS

A. Product: Endura® Compact Grease Interceptor 7-15 GPM as manufactured by Canplas Industries Ltd.

- 1. The unit shall be comprised of engineered thermoplastics to withstand operational temperatures up to 220 degree F (104 degree C) comprising a pedestrian rated cover capable of supporting 440 lb (200 kg) and incorporating an operationally air tight seal. The cover shall also utilize a quick access latching system to functionally retain and secure the cover to the tank, but allow consistent removal and replacement of the cover without operational compromise. Functional elements such as baffles will be made of material that prevents corrosion or deterioration and shall be easily removable for the purposes of maintenance, providing unrestricted upstream and downstream drain access. The grease interceptor shall be certified to the current version of the PDI-G101, ASME A112.14.3 or CSA B481.1 and where locally applicable have UPC listing.
 - a. A flow control device with integrated air intake and tool-less access to the orifice in service shall be provided with the interceptor.

2. Model 3907A02 - Endura® 7GPM/14LB (No-Hub connection – Mechanical Joint coupling). Model 3907A02T - Endura® 7GPM/14LB (Threaded connection). Model 3907A02S - Endura® 7GPM/14LB (Spigot connection).

- a. Flow Rate: 7 US Gallons per Minute (0.44 L per second).
- b. Average Efficiency % (ASME 112.14.3): 95.5%.
- c. Minimum Grease Capacity: 14 lb (6.35 kg).
- d. Grease Capacity Actual: 31.95 lb (14.49 kg).
- e. Unit Weight (Empty): 13.8 lb (6.26 kg).
- f. Liquid Capacity: 12.96 gal (49.06 L).
- g. Connection size: 2 inches (51 mm)

3. Model 3910A02 - Endura® 10GPM/20LB (No-Hub connection – Mechanical Joint coupling) Model 3910A02T - Endura® 10GPM/20LB (Threaded connection). Model 3910A02S - Endura® 10GPM/20LB (Spigot connection).

- a. Flow Rate: 10 US Gallons per Minute (0.63 L per second).
- b. Average Efficiency % (ASME 112.14.3): 92.5%.
- c. Minimum Grease Capacity: 20 lb (9.07 kg).
- d. Grease Capacity Actual: 38.1 lb (17.28 kg).
- e. Unit Weight (Empty): 13.8 lb (6.26 kg).
- f. Liquid Capacity: 12.96 gal (49.06 L).
- g. Connection size (mechanical): 2 inches (51 mm).

4. Model 3915A02C - Endura® 15GPM/30LB (No-Hub connection – Mechanical Joint coupling) Model 3915A02CT - Endura® 15GPM/30LB (Threaded connection). Model 3915A02CS - Endura® 15GPM/30LB (Spigot connection).

- a. Flow Rate: 15 US Gallons per Minute (0.94 L per second).
- b. Average Efficiency % (ASME 112.14.3): 92%.
- c. Minimum Grease Capacity: 30 lb (13.6 kg).
- d. Grease Capacity Actual: 40.97 lb (18.58 kg).
- e. Unit Weight (Empty): 13.8 lb (6.26 kg).
- f. Liquid Capacity: 12.96 gal (49.06 L).
- g. Connection size: 2 inches (51 mm).

B. Product: Endura® Grease Interceptor 20 GPM as manufactured by Canplas Industries Ltd.

1. The unit shall be comprised of engineered thermoplastics to withstand operational temperatures up to 220 degree F (104 degree C) comprising a pedestrian rated cover capable of supporting 440 lb (200 kg) and incorporating an operationally air tight seal. The cover shall also utilize a quick access latching system to functionally secure and retain the cover to the tank, but allow consistent removal and replacement of the cover without operational compromise. Functional elements such as baffles will be made of material that prevents corrosion or deterioration and shall be easily removable for the purposes of maintenance, providing unrestricted upstream and downstream drain access. The grease interceptor shall be certified to the current version of the PDI-G101, ASME A112.14.3 or CSA B481.1 and where locally applicable have UPC listing.
 - a. A flow control device with integrated air intake and tool-less access to the orifice in service shall be provided with the interceptor.
2. **Model 3920A02 - Endura® 20GPM/40LB (No-Hub connection – Mechanical Joint coupling)**
Model 3920A02T - Endura® 20GPM/40LB (Threaded connection).
Model 3920A02S - Endura® 20GPM/40LB (Spigot connection).
 - a. Flow Rate: 20 US Gallons per Minute (1.26 L per second).
 - b. Minimum Grease Capacity: 40 lb (18.1 kg).
 - c. Grease Capacity Actual: 76.4 lb (34.65 kg).
 - d. Average Efficiency % (ASME 112.14.3): 95.4%.
 - e. Unit Weight (Empty): 23 lb (10.4 kg).
 - f. Liquid Capacity: 21.6 gal (81.8 L).
 - g. Connection size: 2 inches (51 mm).
 - h. Optional solids basket accessory Model 3911A-1.
 - i. Modular Riser Extensions: For use with in-floor installations; sized during installation to project requirements. Use up to three (3) full risers per installation (18" maximum height adjustment) Provide with 1 inch markers/ribs on riser to aid height adjustment. All installation components to be supplied by the manufacturer.
 - 1) Model 3920AX6 (Riser extension)

C. Product: Endura® Lo-Pro 25 GPM as manufactured by Canplas Industries Ltd.

1. The interceptor shall be serviced with a minimum of 5 inches (127 mm) of overhead clearance. The unit shall be comprised of engineered thermoplastics to withstand operational temperatures up to 220 degree F (104 degree C) comprising a pedestrian rated cover capable of supporting 440 lb (200 kg) and incorporating an operationally air tight seal. The cover shall also utilize a quick access latching system to functionally secure and retain the cover to the tank, but allow consistent removal and replacement of the cover without operational compromise. Functional elements such as baffles will be made of material that prevents corrosion or deterioration and shall be easily removable for the purposes of maintenance, providing unrestricted upstream and downstream drain access. The grease interceptor shall be certified to the current version of the PDI-G101, ASME A112.14.3 or CSA B481.1 and where locally applicable have UPC listing.
 - a. A flow control device with integrated air intake and tool-less access to the orifice in service shall be provided with the interceptor.

2. Model 3925A02LO - Endura® 25GPM/50LB (No-Hub connection – Mechanical Joint coupling)
Model 3925A02LOT - Endura® 25GPM/50LB (Threaded connection)

- Model 3925A02LOS - Endura® 25GPM/50LB (Spigot connection)**
- a. Flow Rate: 25 US Gallons per Minute (1.6 L per second)
 - b. Minimum Grease Capacity: 50 lb (22.68 kg).
 - c. Grease Capacity Actual: 53.4 lb (24.22 kg).
 - d. Average Efficiency % (ASME 112.14.3): 97.1%.
 - e. Unit Weight (Empty): 23.9 lb (10.85 kg).
 - f. Liquid Capacity: 18.9 gal (71.54 L).
 - g. Connection size: 2 inches (51 mm)

D. Product: Endura® Grease Interceptor 25-35 GPM as manufactured by Canplas Industries Ltd.

1. The unit shall be comprised of engineered thermoplastics to withstand operational temperatures up to 220 degree F (104 degree C) comprising a pedestrian rated cover capable of supporting 440 lb (200 kg) and incorporating an operationally air tight seal. The cover shall also utilize a quick access latching system to functionally secure and retain the cover to the tank, but allow consistent removal and replacement of the cover without operational compromise. Functional elements such as baffles will be made of material that prevents corrosion or deterioration and shall be easily removable for the purposes of maintenance, providing unrestricted upstream and downstream drain access. The grease interceptor shall be certified to the current version of the PDI-G101, ASME A112.14.3 or CSA B481.1 and where locally applicable have UPC listing.
 - a. A flow control device with integrated air intake and tool-less access to the orifice in service shall be provided with the interceptor.
2. **Model 3925ALT02 - Endura® 25GPM/50LB (No-Hub connection – Mechanical Joint coupling)**
Model 3925ALT02T - Endura® 25GPM/50LB (Threaded connection)
Model 3925ALT02S - Endura® 25GPM/50LB (Spigot connection)
 - a. Flow Rate: 25 US Gallons per Minute (1.6 L per second)
 - b. Minimum Grease Capacity: 50 lb (22.68 kg).
 - c. Grease Capacity Actual: 56.25 lb (25.51 kg).
 - d. Average Efficiency % (ASME 112.14.3): 98%.
 - e. Unit Weight (Empty): 45 lb (10.85 kg).
 - f. Liquid Capacity: 39.4 gal (149.1 L).
 - g. Connection size: 2 inches (51 mm)
 - h. Optional solids basket accessory Model 3911A-1.
 - i. Modular Riser Extensions: For use with in-floor installations; sized during installation to project requirements. Use up to three (3) full risers per installation (18" maximum height adjustment) Provide with 1 inch markers/ribs on riser to aid height adjustment. All installation components to be supplied by the manufacturer.
 - 1) Model 3935AX6 (Riser extension)
3. **Model 3925ALT03 - Endura® 25GPM/50LB (No-Hub connection – Mechanical Joint coupling)**
Model 3925ALT03T - Endura® 25GPM/50LB (Threaded Connection)
Model 3925ALT03S - Endura® 25GPM/50LB (Spigot Connection)
 - a. Flow Rate: 25 US Gallons per Minute (1.6 L per second)
 - b. Minimum Grease Capacity: 50 lb (22.68 kg).
 - c. Grease Capacity Actual: 56.25 lb (25.51 kg).
 - d. Average Efficiency % (ASME 112.14.3): 98%.
 - e. Unit Weight (Empty): 45 lb (10.85 kg).
 - f. Liquid Capacity: 39.4 gal (149.1 L).
 - g. Connection size: 3 inches (76 mm)
 - h. Optional solids basket accessory Model 3911A-1.
 - i. Modular Riser Extensions: For use with in-floor installations; sized during installation to project requirements. Use up to

three (3) full risers per installation (18" maximum height adjustment) Provide with 1 inch markers/ribs on riser to aid height adjustment. All installation components to be supplied by the manufacturer.

1) Model 3935AX6 (Riser extension)

a) 1"-6" per riser

4. Model 3935A03 - Endura® 35GPM/70LB (No-Hub connection – Mechanical Joint coupling)
Model 3935A03T - Endura® 35GPM/70LB (Threaded Connection)
Model 3935A03S - Endura® 35GPM/70LB (Spigot Connection)

a. Flow Rate: 35 US Gallons per Minute (2.2 L per second).

b. Minimum Grease Capacity: 70 lb (31.8 kg).

c. Grease Capacity Actual: 138.5 lb (62.8 kg).

d. Average Efficiency % (ASME 112.14.3): 98.6%.

e. Unit Weight (Empty): 45 lb (20.4 kg).

f. Liquid Capacity: 39.4 gal (149.1 L).

g. Connection size: 3 inches (76 mm)

h. Optional solids basket accessory Model 3911A-1.

i. Modular Riser Extensions: For use with in-floor installations; sized during installation to project requirements. Use up to three (3) full risers per installation (18" maximum height adjustment) Provide with 1 inch markers/ribs on riser to aid height adjustment. All installation components to be supplied by the manufacturer.

1) Model 3935AX6 (Riser extension)

5. Model 3935A04 - Endura® 35GPM/70LB (No-Hub connection – Mechanical Joint coupling)
Model 3935A04T - Endura® 35GPM/70LB (Threaded Connection)
Model 3935A04S - Endura® 35GPM/70LB (Spigot Connection)

a. Flow Rate: 35 US Gallons per Minute (2.2 L per second).

b. Minimum Grease Capacity: 70 lb (31.8 kg).

c. Grease Capacity Actual: 138.5 lb (62.8 kg).

d. Average Efficiency % (ASME 112.14.3): 98.6%.

e. Unit Weight (Empty): 45 lb (20.4 kg).

f. Liquid Capacity: 39.4 gal (149.1 L).

g. Connection size: 4 inches (102 mm).

h. Optional solids basket accessory Model 3911A-1.

i. Modular Riser Extensions: For use with in-floor installations; sized during installation to project requirements. Use up to three (3) full risers per installation (18" maximum height adjustment) Provide with 1 inch markers/ribs on riser to aid height adjustment. All installation components to be supplied by the manufacturer.

1) Model 3935AX6 (Riser extension)

E. Product: Endura® Grease Interceptor 50 GPM as manufactured by Canplas Industries Ltd.

1. The unit shall be comprised of engineered thermoplastics to withstand operational temperatures up to 220 degree F (104 degree C) comprising a pedestrian rated cover capable of supporting 440 lb (200 kg) and incorporating an operationally air tight seal. The cover shall also utilize a quick access latching system to functionally secure and retain the cover to the tank, but allow consistent removal and replacement of the cover without operational compromise. Functional elements such as baffles will be made of material that prevents corrosion or deterioration and shall be easily removable for the purposes of maintenance, providing unrestricted upstream and downstream drain access. The grease interceptor shall be certified to the current version of the PDI-G101, ASME A112.14.3 or CSA B481.1 and where locally applicable have UPC listing.

a. A flow control device with integrated air intake and tool-less access to the orifice in service shall be provided with the interceptor.

2. Model 3950A03 - Endura® 50GPM/100LB (No-Hub connection – Mechanical Joint coupling)
Model 3950A03T - Endura® 50GPM/100LB (Threaded Connection)
Model 3950A03S - Endura® 50GPM/100LB (Spigot Connection)

a. Flow Rate: 50 US Gallons per Minute (3.15 L per second).

b. Minimum Grease Capacity: 100 lb (45.5 kg).

c. Grease Capacity Actual: 122.07 lb (55.3 kg).

d. Average Efficiency % (ASME 112.14.3): 93.9%.

e. Unit Weight (Empty): 60 lb (27.2 kg).

f. Liquid Capacity: 52 gal (197 L).

g. Connection size: 3 inches (76 mm)

h. Optional solids basket accessory Model 3911A-1.

i. Modular Riser Extensions: For use with in-floor installations; sized during installation to project requirements. Use up to three (3) full risers per installation (18" maximum height adjustment) Provide with 1 inch markers/ribs on riser to aid height adjustment. All installation components to be supplied by the manufacturer.

1) Model 3935AX6 (Riser extension)

3. Model 3950A04 - Endura® 50GPM/100LB (No-Hub connection – Mechanical Joint coupling)
Model 3950A04T - Endura® 50GPM/100LB (Threaded Connection)
Model 3950A04S - Endura® 50GPM/100LB (Spigot Connection)

a. Flow Rate: 50 US Gallons per Minute (3.15 L per second).

b. Minimum Grease Capacity: 100 lb (45.5 kg).

c. Grease Capacity Actual: 122.07 lb (55.3 kg).

d. Average Efficiency % (ASME 112.14.3): 93.9%.

e. Unit Weight (Empty): 60 lb (27.2 kg).

f. Liquid Capacity: 52 gal (197 L).

g. Connection size: 4 inches (102 mm).

h. Optional solids basket accessory Model 3911A-1.

i. Modular Riser Extensions: For use with in-floor installations; sized during installation to project requirements. Use up to three (3) full risers per installation (18" maximum height adjustment) Provide with 1 inch markers/ribs on riser to aid height adjustment. All installation components to be supplied by the manufacturer.

1) Model 3935AX6 (Riser extension)

F. Product: Endura®XL Grease Interceptor 75 GPM Grease Interceptor as manufactured by Canplas Industries Ltd.

1. The unit shall be comprised of engineered thermoplastics to withstand withstanding prolonged intermittent influent discharge temperatures of 160 degree F (71 degree C) comprising of two load rated covers capable of exceeding loads of 20,000 lb (9072 kg) and incorporating an operationally air tight seal. The covers shall also utilize four (4) mechanical fasteners to functionally secure and retain the covers to the tank, but allow consistent removal and replacement of the cover without operational compromise. Functional elements such as baffles will be made of material that prevents corrosion or deterioration and shall be easily removable for the purposes of maintenance, providing unrestricted upstream and downstream drain access. The grease interceptor shall be certified to the current version of the PDI-G101, ASME A112.14.3, CSA B481.1 and NSF ES15741 and where locally applicable have UPC listing.

a. An integrated flow control device (Internal) with access to the orifice in service shall be provided with the interceptor.

b. An alternate flow control device (External) shall be supplied where required by authority having jurisdiction. External flow control device shall be accessible in operation; and when installed, the internal flow control orifice supplied as standard shall be removed.

2. Model 4075A04 - Endura®XL 75GPM/150LB (No-Hub connection – Mechanical Joint coupling)
Model 4075A04T - Endura®XL 75GPM/150LB (Threaded connection)

a. Flow Control (Internal)

b. Flow Control (External):

1) Model 4044275A (Hub connection)

2) Model 4044275AT (Threaded connection)

c. Flow Rate: 75 US Gallons per Minute (4.7 L per second)

d. Minimum Grease Capacity: 150 lb (68 kg)

e. Grease Capacity Actual: 559 lb (254 kg)

- f. Average Efficiency %: (ASME 112.14.3 / NSF ES15741) => 98%
- g. Unit Weight (Empty): 233 lb (106 kg)
- h. Liquid Capacity: 158 gallons (598 L)
- i. Connection size: 4 inches (102mm)
- j. Traffic Rated Cover: Designed to comply with AASHTO 304 minimum design load - 16,000 lb (7257 kg).
- k. Cover Load Capability: Tested and third party approved based on CSA Class 'S' "Special Duty" requirements. Proof load minimum 20,000 lb (9072 kg). To validate performance in external applications testing shall include evaluation for elevated and sub-zero temperatures.
- l. Extension Risers: For use below grade; sized to project requirements. Provide with 1 inch markers/ribs on riser and flanged bottom to interlock to frame. All installation components to be supplied by the manufacturer (outlet extension adaptors, seals and mechanical fasteners). Pipe for handle extension by others.
 - 1) Model 40100AX35 (Riser extension pair – long format)
 - a) 4"–35" per riser
 - 2) Model 40100AX18 (Riser extension pair – short format)
 - a) 4" – 18" per riser

G. Product: Endura®XL Grease Interceptor 100 GPM Grease Interceptor as manufactured by Canplas Industries Ltd.

1. The unit shall be comprised of engineered thermoplastics to withstand prolonged intermittent influent discharge temperatures up to 160 degree F (71 degree C) comprising of two load rated covers capable of exceeding loads of 20,000 lb (9072 kg) and incorporating an operationally air tight seal. The covers shall also utilize four (4) mechanical fasteners to functionally secure and retain the covers to the tank, but allow consistent removal and replacement of the cover without operational compromise. Functional elements such as baffles will be made of material that prevents corrosion or deterioration and shall be easily removable for the purposes of maintenance, providing unrestricted upstream and downstream drain access. The grease interceptor shall be certified to the current version of the PDI-G101, A112.14.3, CSA B481.1 and NSF ES15741 and where locally applicable have UPC listing.
 - a. An integrated flow control device (Internal) with access to the orifice in service shall be provided with the interceptor.
 - b. An alternate flow control device (External) shall be supplied where required by authority having jurisdiction. External flow control device shall be accessible in operation; and when installed, the internal flow control orifice supplied as standard shall be removed.
2. **Model 40100A04 - Endura®XL 100GPM/200LB (No-hub connection - Mechanical Joint coupling)**
Model 40100A04T - Endura®XL 100GPM/200LB (Threaded connection)
 - a. Flow Control (Internal)
 - b. Flow Control (External):
 - 1) Model 40442100A (Hub Connection)
 - 2) Model 40442100AT (Threaded connection)
 - c. Flow Rate: 100 US Gallons per Minute (6.3 L per second)
 - d. Minimum Grease Capacity: 200 lb (90.8 kg)
 - e. Grease Capacity Actual: 1058 lb (479.9 kg)
 - f. Average Efficiency %: (ASME 112.14.3 / NSF ES15741) => 98%
 - g. Unit Weight (Empty): 283 lb (128.3 kg)
 - h. Liquid Capacity: 257 gallons (972 L)
 - i. Connection size: 4 inches (102mm)
 - j. Traffic Rated Cover: Designed to comply with AASHTO 304 minimum design load - 16,000 lb (7257 kg).
 - k. Cover Load Capability: Tested and third party approved based on CSA Class 'S' "Special Duty" requirements. Proof load minimum 20,000 lb (9072 kg). To validate performance in external applications testing shall include evaluation for elevated and sub-zero temperatures.
 - l. Extension Risers: For use below grade; sized to project requirements. Provide with 1 inch markers/ribs on riser and flanged bottom to interlock to frame. All installation components to be supplied by the manufacturer (outlet

extension adaptors, seals and mechanical fasteners). Pipe for handle extension by others.

- 1) Model 40100AX35 (Riser extension pair – long format)
 - a) 4"–35" per riser
- 2) Model 40100AX18 (Riser extension pair – short format)
 - a) 4" – 18" per riser

2.4 SOLIDS INTERCEPTOR

H. Product: Endura® Solids Interceptor as manufactured by Canplas Industries Ltd.

1. Parts in direct contact with flow shall be constructed of engineered thermoplastic capable of withstanding operational temperatures up to 220 degree F (104 degree C). Baffles shall be perforated with slots as opposed circular perforations for enhanced straining of elongated debris e.g. mop strings, spaghetti etc. The solids interceptor basket component shall be removable for cleaning and in operation have a minimum flow rate greater than 50 GPM (3.2 liter per second) when loaded to 50% of its solids-holding capacity. Any baffles/straining method used shall also be removable for maintenance and operation shall use a dual means of filtration on solid material within the flow. When installed in a stand-alone configuration the tank will meet the same specification as above and have both a lid which is airtight and capable of supporting 440 lb (200 kg).
2. Model 3911A02: Solids Interceptor. Complete with Solids Basket Accessory (SBA):
 - a. Flow Rate: <50 GPM.
 - b. Average Efficiency % (Internal Testing Only): 98%.
 - c. Unit Weight (Empty): 19.4 lb (8.18 kg)
 - d. Liquid Capacity: 12.96 gal (49.06 L).
 - e. Connection size: 2 inches (51 mm) - (No-hub connection - Mechanical Joint coupling)

PART 3 EXECUTION

3.1 EXAMINATION

- A. Do not begin installation until substrates have been properly prepared.
- B. If substrate preparation is the responsibility of another installer, notify Architect of unsatisfactory preparation before proceeding.

3.2 PREPARATION

- A Clean surfaces thoroughly prior to installation.
- B. Prepare surfaces using the methods recommended by the manufacturer for achieving the best result for the substrate under the project conditions.

3.3 INSTALLATION

- A. Install in accordance with manufacturer's instructions.
- B. Do not pressurize any interceptor as there is a serious risk of injury and death. The interceptor as an appurtenance shall be isolated for the purposes of leak testing the upstream and downstream drainage system when commissioning and verifying the system operation.
- C. Interceptor tank will be installed to the associated drainage system using mechanical joint couplings approved by the Authority Having Jurisdiction (AHJ). Supplied by others.
- D. When installing in-floor tanks will be filled to static water level with water to prevent movement and resist pressure of backfilling process.
- E. Cover will be secured in place during backfilling process to maintain structural rigidity and form and to prevent ingress of foreign bodies into both the interceptor and drainage system.

3.4 FIELD QUALITY CONTROL

- A. Provide inspection certificates of Authority Having Jurisdiction (AHJ).

3.5 PROTECTION

- A. Protect installed products until completion of project.
- B. Touch-up, repair or replace damaged products before Substantial Completion.

END OF SECTION

Notes:

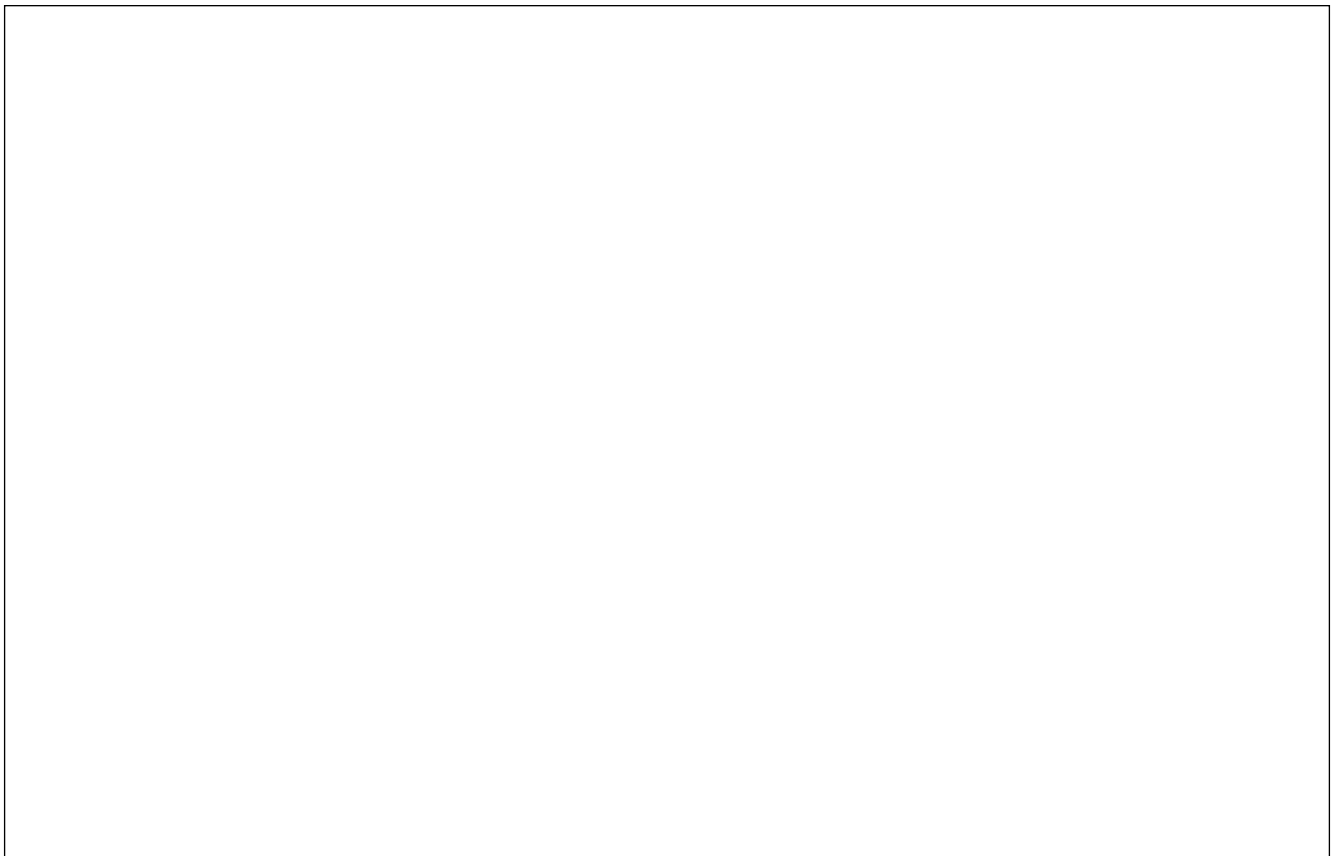

endura®



Endura® Grease Interceptors are manufactured in a ISO 9001 and 14001 registered facility. Our quality management system has been registered for the design, manufacture and distribution of high quality injection molded products used in plumbing, industrial, ventilation and central vacuum applications.



www.arcat.com



www.csc-dcc.ca



www.csinet.org

Canada
Tel: (705) 726-3361
1-800-461-1771
Fax: (705) 726-2186

U.S.A.
Tel: (303) 373-1918
1-888-461-5307
Fax: (303) 373-1923



Technical Support
tech-support@endurainterceptor.com