

# Liberty Pumps®

## CSP-Series

### Crawl Space Sump Pump Kit

For dewatering under homes, basements, crawl space areas or where water may accumulate

#### Features:

- Heavy-duty submersible sump pump in 1/3 or 1/2 hp
- 6.5" x 15" perforated polyethylene sump pit with cover
- 24' x 1-1/4" flexible hose kit, polyethylene
- System is unassembled
- Check valve

Controls problems with mold, fungus, moisture and structural damage. Reduces problems with rodents, insects and pests attracted to wet environments.

**Energy Saving! Model**

Efficient motor design reduces electrical usage by up to **40%**



#### Models:

CSP-237 1/3 hp Poly/Aluminum sump pump

CSP-457 1/2 hp Poly/Aluminum sump pump

CSP-257 1/3 hp Cast Iron sump pump

innovate. evolve.

# CSP-SERIES

## CRAWL SPACE SUMP PUMP KIT

### MODELS

CSP-237 - 1/3 hp, 115 volt, poly/aluminum sump pump (model 237)

CSP-457 - 1/2 hp, 115 volt, poly/aluminum sump pump (model 457)

CSP-257 - 1/3 hp, 115 volt, cast iron sump pump (model 257)

See specific 230-Series, 250-Series or 450-Series literature for complete pump specifications.

**Weight:** CSP-237 23 lbs  
CSP-457 25 lbs  
CSP-257 30 lbs

### Kit Contains:

- 16.5" x 15" poly sump pit (perforated) and poly cover
- Automatic sump pump, 115 V, with 10' power cord
- 24' flexible hose kit, polyethylene 1-1/4" (Model DHK-24)
- Check valve threads directly into pump discharge
- System is unassembled

### PERFORMANCE CURVE

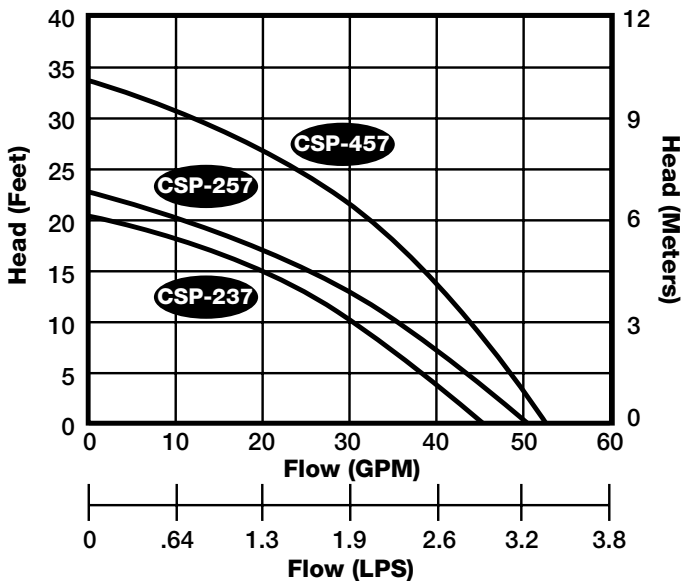

Maximum Fluid Temperature 140° F

### DIMENSIONAL DATA

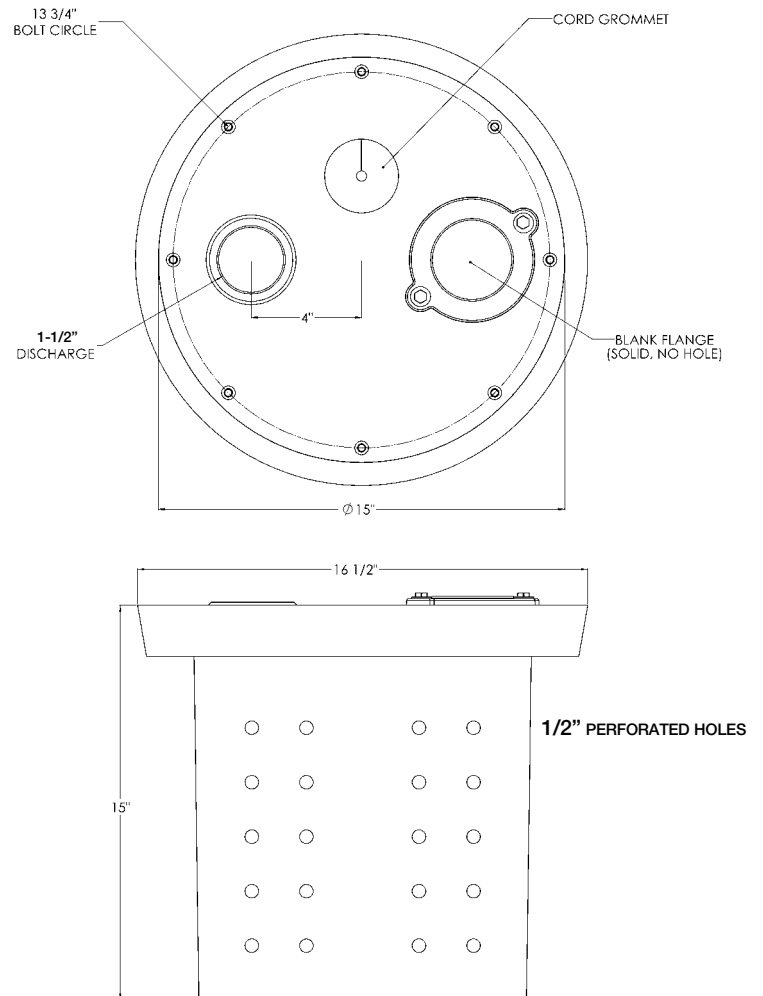

us Certified Pumps

Specifications subject to change without notice.