



BISHOP: 12V & 24V Brass Up Light

| | |
|-----------------|--|
| PROJECT: | |
| TYPE: | |
| CATALOG NUMBER: | |
| LAMP(S): | |
| NOTES: | |

FIXTURE ORDERING INFORMATION

Example: BISH-12-L1030 (Bishop, 12 Volt, 10 Watt, 3000K LED PAR 36, 25' Wire Lead, Weathered Brass)

| MODEL NAME | VOLTAGE | WATTAGE | WIRE LENGTH | FINISH | OPTIONS |
|------------|--------------------------|---|---|--|----------------|
| BISH | 12=12 Volt 24=24 Volt | L627= LED, 6W, 2700K, Flood L630= LED, 6W, 3000K, Flood L1027= LED, 10W, 2700K, Flood L1030= LED, 10W, 3000K, Flood L1827= Led, 18W, 2700K, FLOOD L1830= Led, 18W, 3000K, FLOOD 35= 35W PAR36 NL=No Lamp | Leave blank for standard 25' length * 0= 3' wire lead * 50= 50' wire lead | Leave blank for standard WB finish P= Powder coat finish. Specify color from chart below and mark in order comments area. | * 6P= Six Pack |

NOTE: Pre-lamped LED fixtures are NOT available with 24V lamps. LED fixtures and six pack options are available ONLY with a 25' wire lead. For additional painted finishes or six pack options contact our factory.

Powder Coated Finishes

| | |
|-----------------|----|
| Tucson Tan | TT |
| White | WH |
| Black | BK |
| Verde Green | VG |
| Titanium Knight | TK |

Standard Finish

| | |
|-----------------|----|
| Weathered Brass | WB |
|-----------------|----|

Stock powder coated colors displayed are subject to varying lead-times and will incur an additional cost. A Limited Warranty applies to all powder coated products. Custom colors are available upon request. Please inquire about cost and lead times. Contact factory for custom colors and matching paint options.

DIMENSIONS:

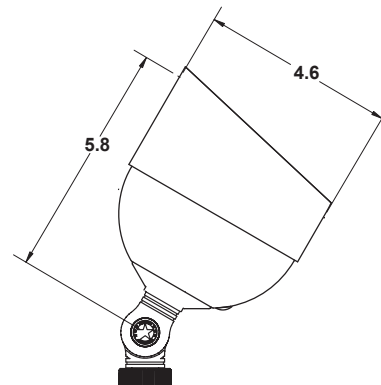

FLEX™ Unique Lighting Systems® fixtures are available with LED lamps. Please specify the lamp code when ordering.

* Only available with the NL wattage option. Unique Lighting Systems® reserves the right to modify the design and/or construction of the fixture shown without further notification.

SPECIFICATIONS

Our Commitment

Unique Lighting Systems' highest commitment is to set the standard for manufacturing innovative and quality products. This commitment is evident through our detailed inspection processes and extensive field testing. From the initial design process of each product, to the final assembly of each custom-made individual part, our manufacturing process accomplishes the highest level of performance and durability carried through to final delivery to the end user. Durable construction and beautiful styling make Unique™ fixtures the ideal solution for any residential and/or commercial application. Unique Lighting™ already holds numerous product patents and we are constantly developing innovative ideas to help expand the lighting industry.

Body

Precision extruded from brass. Features an integral knuckle for maximum mechanical strength.

Gasket

High temperature silicone o-ring for water-tight seal.

Knuckle

Machined brass knuckle with a solid brass adjustable thumb screw. Vertical tilt of 270° and horizontal rotation of 360° for easy aiming. The Orbital Lock Nut™ allows for locking the horizontal rotation without adjusting the stake.

Shroud

Precision extruded from brass.

Lamp

For use with a halogen lamp up to 35W PAR36 lamp. **FLEX™** Series LED lamps are available in 6W, 10W and 18W PAR36 lamps. LED lamps are available in 2700K and 3000K color temperatures.

Electrical Requirements

A remote 12V or 24V transformer required, may be ordered separately from Unique Lighting Systems®. Voltage range for 12V halogen lamps is 10.8V to 12V. Voltage range for 24V halogen lamps is 21.6V to 24V. Voltage range for **FLEX™** Series LED PAR36 lamps is 10V-15V.

Lamp Connection

PAR 36: Screw terminal.

Wiring

Exclusive UF Intelli-Flex wire with anti-moisture migration connections.

Mounting Stake

Standard mounting stake is injection molded PVC with a ½" NPS threaded female fitting.

Finish

Exclusive Weathered Brass finish is standard. Unique™ Lightings' Weathered Brass finish is a "living finish" and will naturally patina and change over time. Polyester powder coat finishes are also available (see chart above).

Warranty

The Brass Knights™ Family of products from Unique Lighting Systems® carries a limited 15 year warranty against manufacturer's defects.

Manufacturing

Manufactured to ISO 9001-2008 Quality Systems Standard.



UL 2108:2004 R12.07
CSA C22.2.9.0-96 (R2006)