



FORD PERFORMANCE

M-16612-C20

2020 GT500 Carbon Fiber Hood Vent with Rain Tray
Installation

Carbon Fiber Hood Vent with Rain Tray

PLEASE READ ALL OF THE FOLLOWING INSTRUCTIONS CAREFULLY PRIOR TO INSTALLATION. AT ANY TIME YOU DO NOT UNDERSTAND THE INSTRUCTIONS, PLEASE CALL THE ANDERSON COMPOSITES CUSTOMER SERVICE LINE AT 1- 877-624-2662 (9:00 AM – 5:30 PM CALIFORNIA TIME, MON-FRI)

OEM HOOD VENT/RAIN TRAY ASSEMBLY REMOVAL

1. Open the hood
2. Remove the thirteen (13) bolts, save for installation
3. Pull out the front edge of hood scoop and remove the two (2) pin-type retainers, be careful not to damage upon removal and save for installation
4. Slide assembly up and remove the hood scoop/rain tray assembly
5. Place assembly on a soft cloth (hood vent side down)
6. Remove the eight (8) T25 Torx fasteners and (2) rubber bumpers from rain tray, save for reassembly
7. Wrap assembly in a soft cloth to prevent scratches, store in safe location to prevent damage

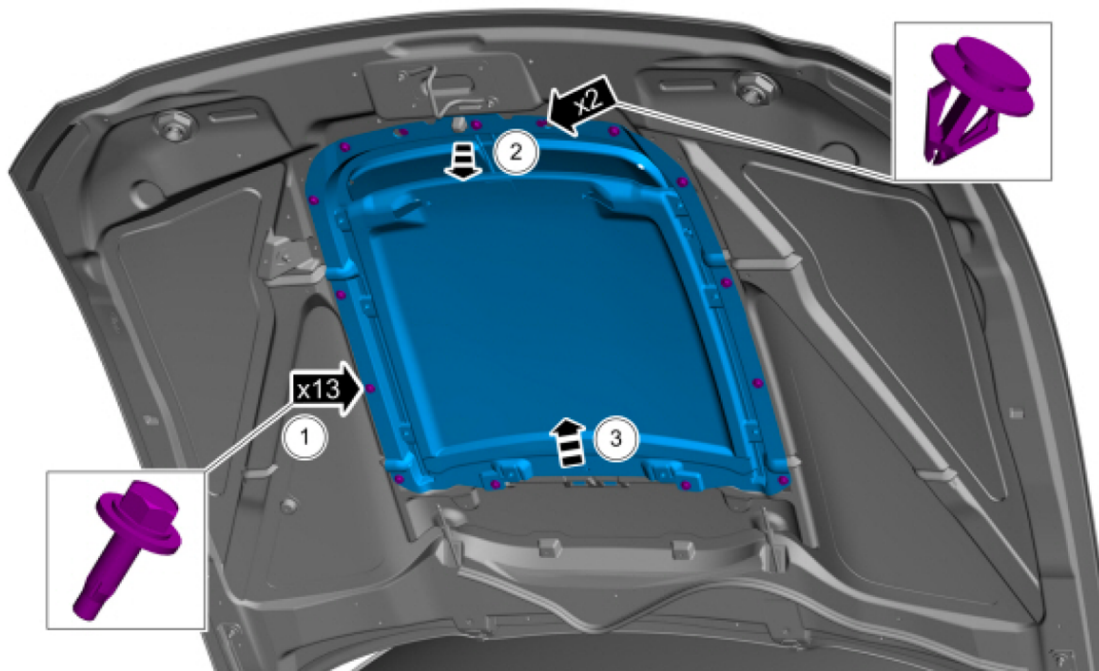



FORD PERFORMANCE

M-16612-C20

2020 GT500 Carbon Fiber Hood Vent with Rain Tray
Installation

Carbon Fiber Hood Vent with Rain Tray

CARBON FIBER RAIN TRAY ASSEMBLY

1. Position carbon fiber hood vent face down on soft cloth
2. Test fit carbon fiber rain tray on carbon fiber hood vent, replicate OEM assembly, remove carbon fiber rain tray
3. Insert the eight (8) provided fasteners in square holes in the carbon fiber hood vent (B), do not force, may require minor sanding to fit properly
4. Install (2) rubber bumpers on carbon rain tray
5. Align the carbon fiber rain tray with the alignment posts (A) on the carbon fiber hood vent, insert eight (8) T25 Torx fasteners (B), hand tighten.

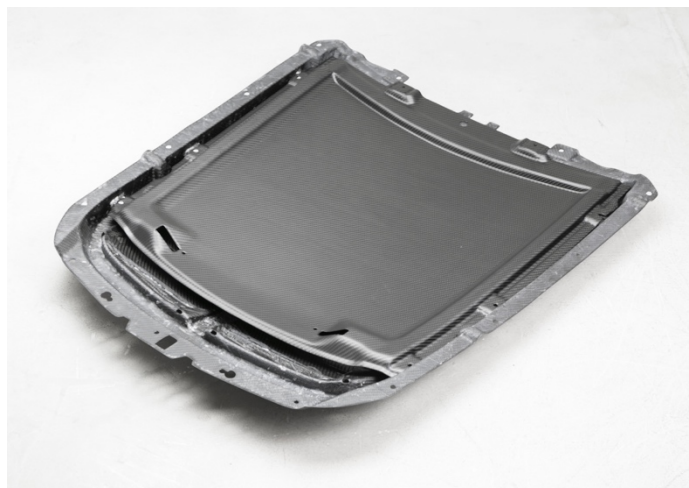
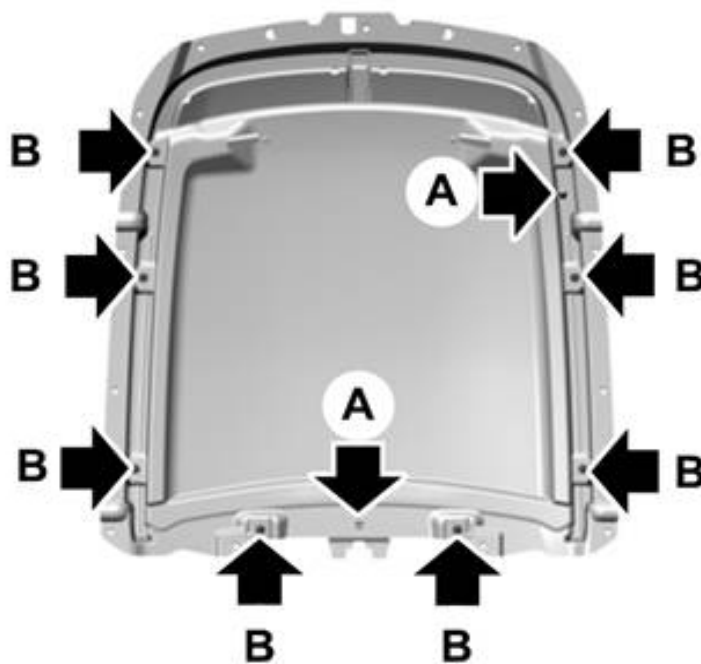



FORD PERFORMANCE

M-16612-C20

2020 GT500 Carbon Fiber Hood Vent with Rain Tray
Installation

Carbon Fiber Hood Vent with Rain Tray

CARBON FIBER HOOD VENT/RAIN TRAY ASSEMBLY INSTALLATION

1. To install, reverse the removal process
2. Carbon fiber mounting surfaces may require modifications for correct fitment; minor adjustments may be necessary as part of the normal installation process
3. Carbon fiber hood vent and rain tray will not sustain heavy force or weight, use minimal pressure during installation

29 lb. in
(3Nm)

