

Date: \_\_\_\_\_ Location: \_\_\_\_\_  
 Product: \_\_\_\_\_ Project: \_\_\_\_\_  
 Quantity: \_\_\_\_\_ Catalog #: \_\_\_\_\_

## LED LOC-EMDR Emergency Driver Series

### FEATURES

- Listed to UL924
- Test to CSA C22.2 NO. 141 Field or factory installation
- High output voltage
- Low energy consumption CEC Title 20 compliant
- Constant output power
- Self-testing
- Battery: Li-ion
- Battery: over temperature protection
- Ambient Temp: Li-ion: 0°-50°C (32°F-122°F)
- 5-year warranty



### SELF-TESTING

- The emergency LED driver contains a control/monitor circuit which will perform a 30-second discharge test once a month and a full discharge test once a year. At this time, the unit will simulate an AC power failure and automatically switch to emergency mode. During routine testing, the unit will monitor the operation of the LED load, battery voltage and emergency duration. If the unit detects any problems, the indicator will flash quickly.

### CAUTION

- During AC operation, remember not to touch or remove and wires in case of electrical shock.
- During emergency operation, before touching and disconnecting the wires, remember to press the test button again to make the LED lamp and indicator light turn off to avoid electric shock.
- The voltage input to the dimmable wires (DIM+, DIM-) of emergency LED driver must be less than 20Vdc.
- Maximum suggested LED fixture wattage is

### FUNCTION

- AC operation, indicator light will keep on.
- Emergency operation, indicator light will flash slowly (light on for 2 seconds, light off for 2 seconds).
- In a failure, indicator light will flash quickly (light on for 0.2 seconds, light off for 0.2 seconds).

### TEST SWITCH

- In AC operation, press the test switch once to run the emergency power for 30 seconds.
- In AC operation, press the test twice within 3 seconds to make the battery full discharge.
- In emergency operation, press the test switch once. This will turn off both the emergency as well as the lamp and indicator light at the same time.

MODEL NUMBER	INPUT VOLTAGE	INPUT CURRENT	INPUT POWER RATING	OUTPUT VOLTAGE	EMERGENCY POWER	RECHARGE TIME	DISCHARGE TIME
LOC-EMDR-25WHV	100-347Vac, 50/60Hz	200mA max.	12W max.	170Vdc	25W max.	24Hrs.	90 mins.
LOC-EMDR-40WHV	100-347Vac, 50/60Hz	200mA max.	12W max.	170Vdc	40W max.	24Hrs.	90 mins.

<b>Series</b>	<b>Type</b>	<b>Wattage</b>
LOC-EMDR	Emergency Driver	25W 40W

**MEASUREMENTS**

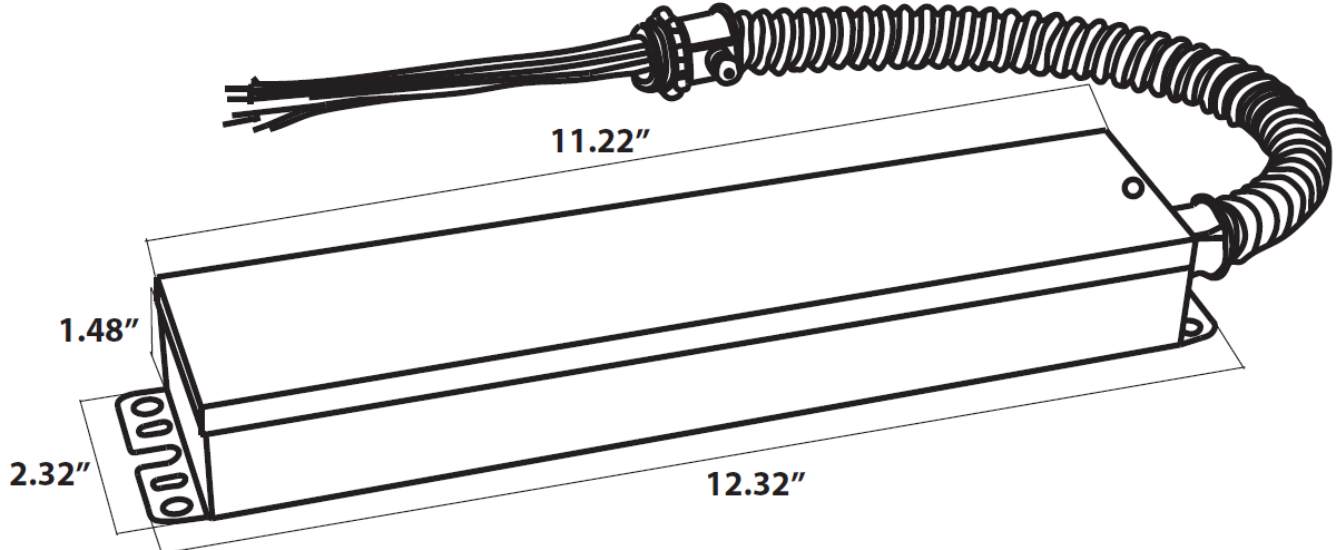

MODEL	QUANTITY	WEIGHT	UPC CODE
LOC-EMDR-25WHV	1	2.65lbs	00815586029891
LOC-EMDR-40WHV	1	2.65lbs	00810050941488