



GOLDEN
ELECTRIC
CYCLES

FALKEN

ConJet

1. WELCOME.....	2
2. GENERAL WARNING.....	3
3. A NOTE TO PARENTS.....	3
4. UNBOXING.....	4
5. OBJECTS INCLUDED.....	5
6. GETTING STARTED.....	6-7
7. SAFETY INSTRUCTIONS.....	8
8. POWERING ON AND SAFETY TIPS.....	9
9. REMOVING THE BATTERY.....	10
10. CHARGING TIPS.....	11
11. WARRANTY.....	12-13
12. RELEASE OF LIABILITY.....	14
13. ENGRAVE CODES.....	15

welcome

Congratulations! *You have in your possession one of the finest bicycle products in the world. The following pages will provide you with the information you need to properly use, adjust, maintain, and service your new bike, so you can get the most out of every ride!*



It is essential that you read this owner's manual thoroughly before riding your bicycle. *We know you're anxious to ride, but trust us, it will only take a few minutes, and then you can unleash the full potential of your bicycle.*

In order to prevent serious injury, please pay close attention to the safety and caution information located in this manual. If you encounter any issues with your bicycle that aren't covered in this guide, please contact your nearest authorized dealer. Consider Golden Cycles as your number one dealer to answer questions, perform required maintenance, and recommend the best equipment and gear to compliment your ride.

*Please contact us to see which available
Authorized Dealer is in your area (pg.3)*

*Thank You for buying Golden Cycles! We are
proud to be your brand of choice*

SERIAL # _____

Now Go Ride!

General warning

*Like any sport, **bicycling involves risk of injury and damage.** By choosing to ride a bicycle you assume the responsibility for that risk; so you need to know and **practice the rules of safe and responsible riding** and proper use and maintenance, as this can reduce risk of injury.*

*This guide contains many **warnings** and **cautions**, failure to follow these guidelines can lead to serious injury. Our inability to anticipate every situation or condition which can occur while riding makes this guide no representation about the safe use of the bicycle under all conditions. There are risks associated with the use of any bicycle which cannot be predicted or avoided and which are the sole **responsibility of the rider.***

a note to parents

*We recommend this bicycle for adults, if you choose to have your child ride it please be aware it is at **your sole responsibility, and personal liability.** IF you allow your child to ride make sure they wear an **approved DOT bicycle helmet** at all times. A bicycling helmet is intended for bicycling only, failure to follow this warning may result in serious injury or death.*

*As a parent/guardian you are responsible for the activities and safety of your child. This includes making sure the **bicycle is properly fitted** to the child, that is it in **good repair and safe operating condition**; that your child has learned and understands the safe operation of a bicycle, that your child has learned, understands, and obeys local motor vehicle laws, bicycle and traffic laws, and the common sense rules of safe and responsible cycling. You should read this manual carefully before allowing your child to ride the bicycle.*

Unboxing

1. *You have your new bike! Don't be shy, open it, and make sure to be careful when using sharp knives to open it. Ensure that your order has arrived in perfect condition by opening the top of the box and examining the bike.*
2. *Now take it out.*
*When taking out the bike from the box keep in mind that eBikes are usually a lot heavier than standard bikes. **Ask for help** if needed. (Pro Tip: Cut the box open from the side. Use knives in a safe manner!)*
3. *Remove the packaging. Be careful not to cut yourself with staples in the box or when cutting off ties on the packaging. Make sure to remove the protector on the left side of the front wheel. Here are the tools you will need to assemble the bicycle and what you will find inside the package...*

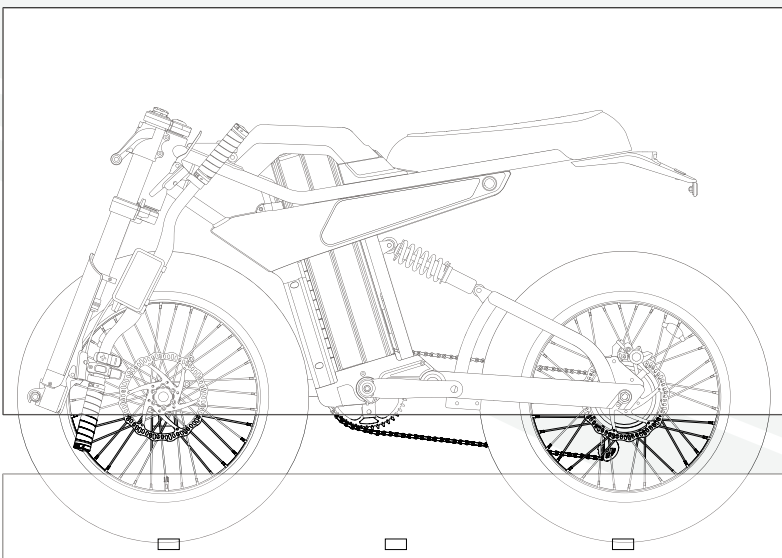

objects included



Key*3



Gasket*2



Headlight*1



M8*25
Screw*2

13-15#
wrench * 1

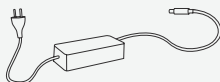

Charger*1

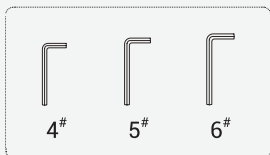

Hexagon wrench * 3

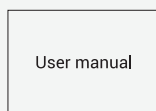

User manual * 1



Pedal*2



Front fender*1



Press block assembly*1

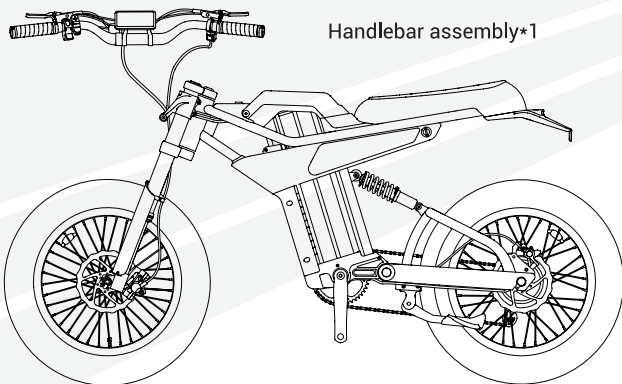

Handlebar assembly*1

Bike body*1

getting started

Unscrew the bolts out of the clamp as shown below

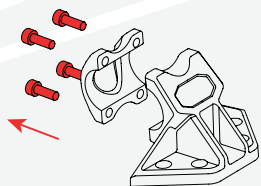

Place the screen and handle bar in position, then align the bolts as shown below and tighten with 5# Allen wrench

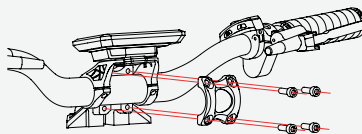

Use allen wrench #5 to unscrew any of the bolts.

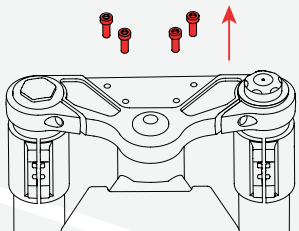

Align the handlebar with the upper plate as shown below.

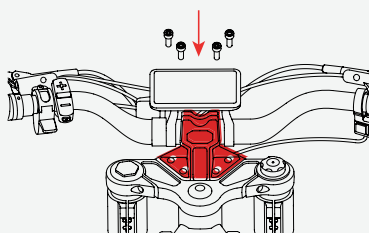

Once you have placed the handle bar and plate in position make sure to screw the bolts back in.

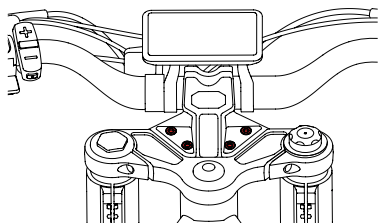

Align the front fender as shown below

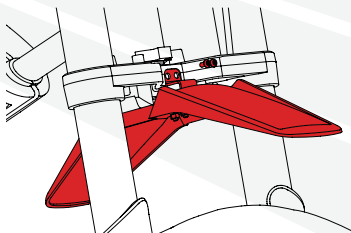

getting started

Once the fender is align correctly, screw the bolts with a 4# Allen wrench.

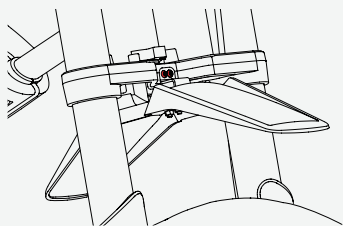

Place the gasket inside the bracket.

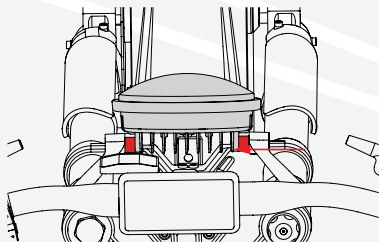

Place the M8*25 screws in the holes on both sides of the headlight.

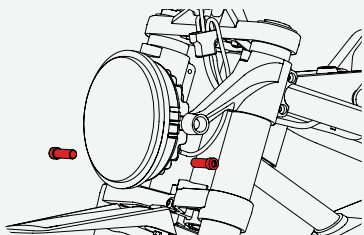

Once screws are place in, use the #6 allen wrench to tighten the bolts.

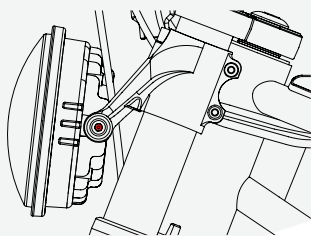

Screw the left pedal counter-clockwise and the right pedal clockwise.

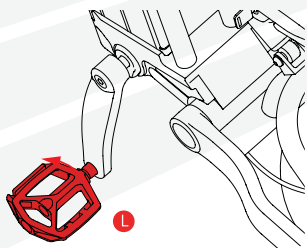



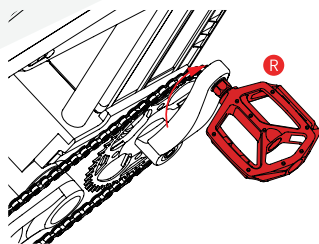

Tighten the pedals as tight as you can with a 15mm pedal wrench.

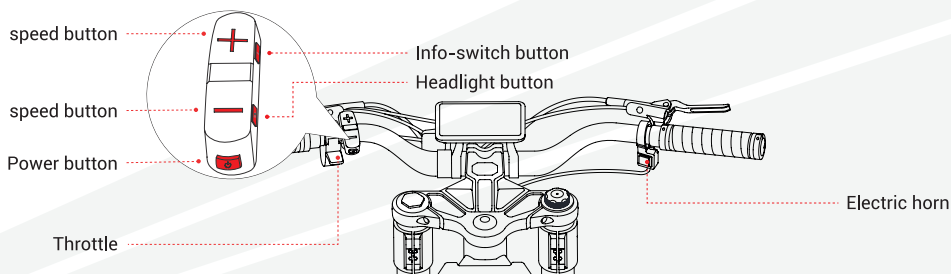

powering on and tips



	Power button	Press and hold the button down to turn on/ off.
	Plus button	Press the key to increase speed. Press and hold for three seconds tu turn on high beam light.
	Minus button	Press the key to decrease speed.
	Info-switch button	Press the key to display information such as: Total mileage, Single Mileage, Maximum Speed and Average Speed.
	Headlight button	Press the button to turn on low beam lights.

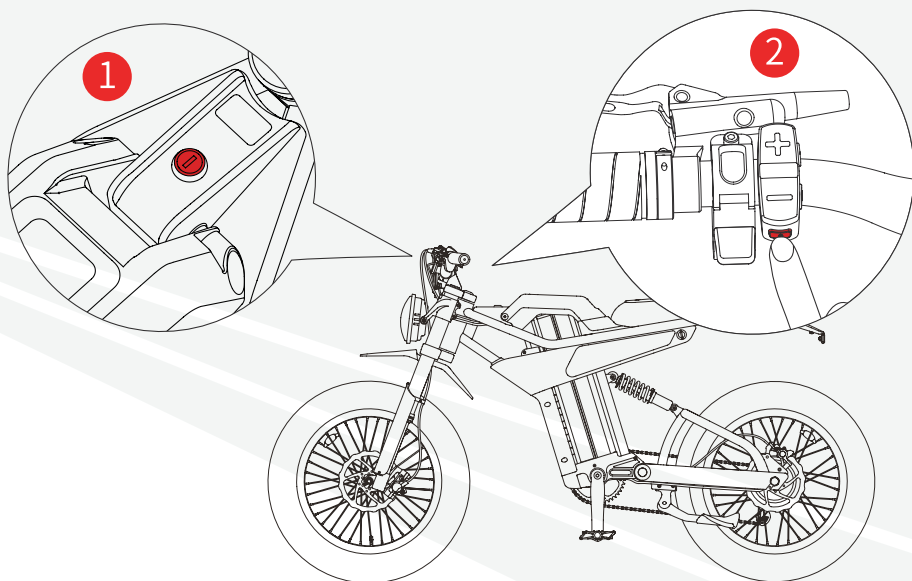

- ① Insert key to turn on the battery lock.
- ② Press power button to turn the engine on and check battery status.
if the charge is too low, please charge it immediately.

lcd screen

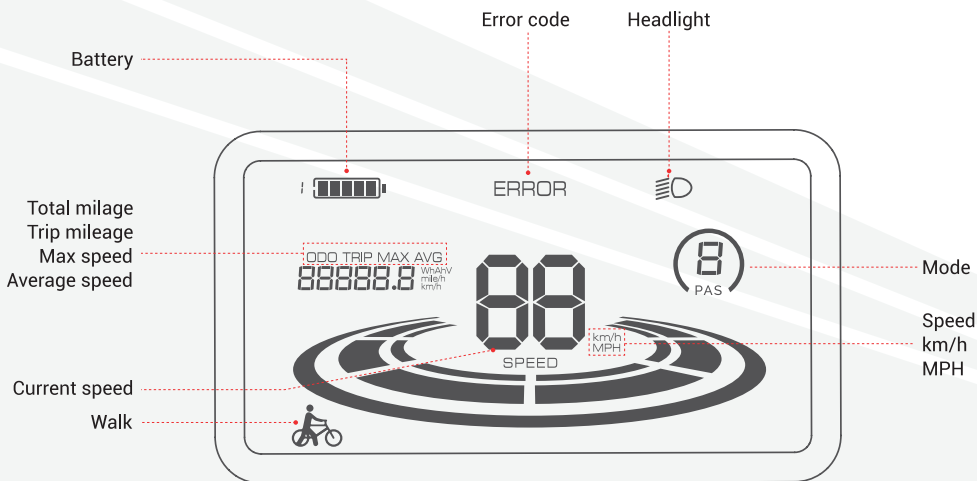

Error number	Failure type
E001	Controller error
E002	Communication error
E003	Motor hall error
E004	Throttle error
E005	Brake lever error
E006	Motor error

Removing the battery

Unlock the battery lock by inserting the key and twisting to the right.

Lift up the battery cover as shown in the picture below.

To remove the battery, all you have to do is grab the battery handle and pull it up.

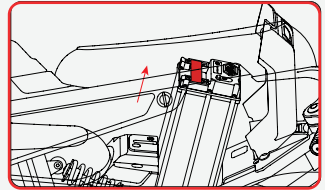
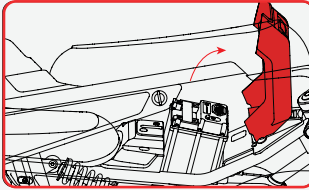
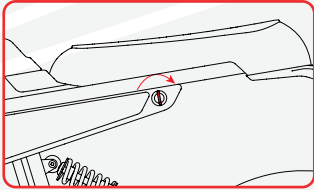

charging tips

Due to battery consumption during transportation and storage, it is normal for the battery to be low when used for the first time.

So here's two ways to charge your new E-bike:

2. 1-EXTERNAL CHARGE

On the right side of your bike, you will find a charging port, open it up and plug to any power outlet as shown below.

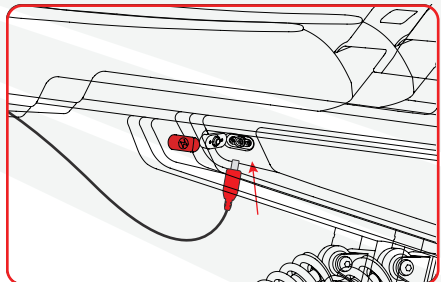
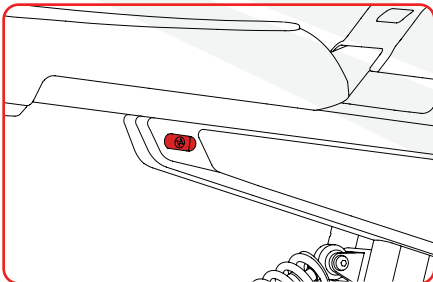

charging tips

2.- INTERNAL CHARGE

Remove the battery (as shown in page E 10.) and find the charging port placed on top of the battery.

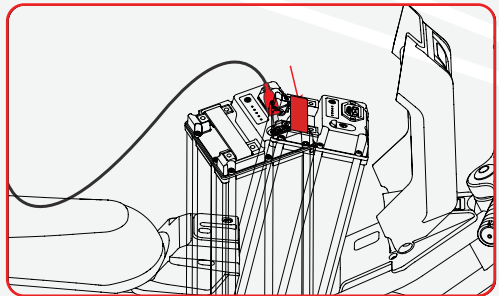
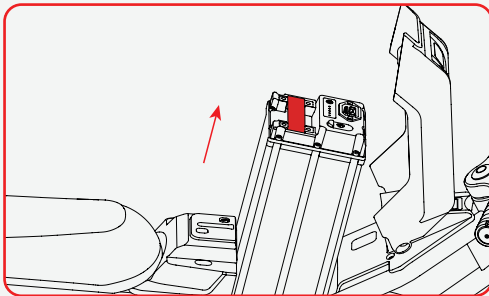

warning

- 1.- Please turn off the bike before you charge it.*
- 2.-Only use charger designated for this bike, any after market battery can cause damage to the battery.*
- 3.-If the indicator light is abnormal or there is an abnormal smell, please stop charging immediately.*
- 4.-Keep charger in a safe place away from children.*
- 5.- Unplug from power outlet right after the battery has been charged.*
- 6.If the charger is damaged in some type of way, please stop using it.*

Warranty

	Part	Warranty Period	
Electronic control unit	Motor	12 Months	
	Battery		
	Controller	6Months	
	Charger	3Months	
	Sensor		
	Display/Dashboard		
Mechanical parts	Frame	24 Months	
	Fork	12 Months	
	Tires	3Months	
	Saddle		
	Other Parts		
	Front/Middle axle		

NOTE:

If the motor breaks down after it has been replaced, cost even if it's within the warranty period.

Warranty

Warranty Scope
Malfunction/ break down / performance failure
Malfunction/power capacity being lower than 50%.
Performance failure
Performance failure
Performance failure
Performance failure
Desoldering/material fracture
Performance failure
Crack/leaking
Crack/damaged
Damaged/performance
Performance failure

you'll be charged for the replacement and shipping

release of liability

please read carefully.

Bicycle riding is a hazardous sport and/or activity.

This bicycle bought from Innovative Sports Distribution and Zyclefix Bicycles Inc. or any of its authorized bicycle dealers and/or distributors is understood to be the consumer's sole responsibility and legal liability.

I, the consumer and purchaser of this Golden Cycles branded bicycle and/or product understand and acknowledge that bicycle riding may cause injury or death due to normal use, abuse, poorly maintained equipment, stunt riding, road terrain and/or accidents. I hereby release Innovative Sports Distribution and Zyclefix Bicycles Inc., its owners, affiliates and employees from any and all legal liability from injury, property damage, and death to myself, or my minor children and anyone that rides this bicycle. The rider assumes full responsibility and liability resulting from assembly, maintenance, or use (as stated above) of any such equipment. I agree to defend, indemnify and hold harmless Innovative Sports Distribution and Zyclefix Bicycles Inc. for and from any injury to other person(s) or property which I may cause as a result of engaging in the activity of riding a bicycle from this distributor.

Codes

This number is engraved on the motor as shown below:

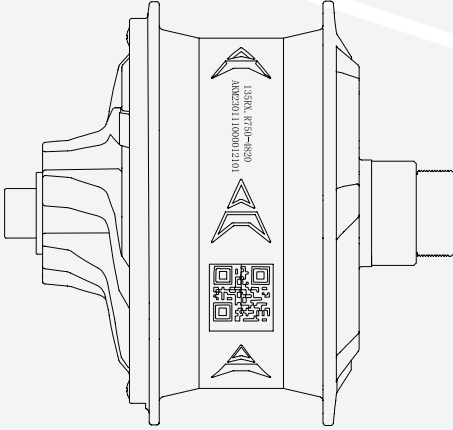

Details of serial number:

135RX.R750-4820
AKM 230404 00001 0001

AKM: Company initials;
230404: Order year, month, day;
00001: Fixed code unchanged;
0001: Production serial number;

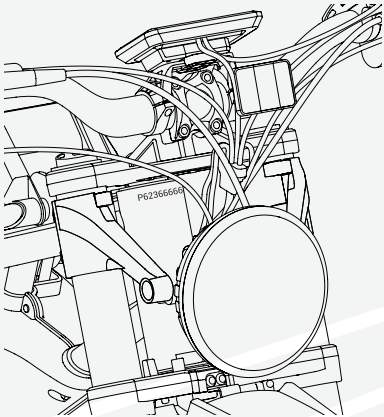

Details of serial number:

P62366666

P6: Product model;
23: Production year, indicating 2023;
66666: Production serial number,
from 00001 to 99999; 66666

Safe riders



ALWAYS
WEAR A HELMET



USE SAFETY LIGHTS
DILIGENTLY



DON'T RIDE AT
NIGHT



MAKE SURE YOU
CAN RIDE AT
HIGH SPEED