



### ***The Next Generation of Portable Balances for your Classroom***

Designed for education applications, the OHAUS Scout with large backlit LCD backed by education software is the ideal balance for your classroom. It is built to endure demanding classroom applications with superior overload protection. Features including faster stabilization time, increased capacity, multiple connectivity options and stackable design make Scout the best weighing experience for the next generation classroom.

#### ***Standard Features Include:***

- **Superior Overload Protection & Practical Stackable Design for Convenient Storage**  
Integrated superior overload protection system rated at 10 times the capacity protects the balance in demanding classroom environments. Space-saving design allows for stackable storage (excluding 1mg model).
- **Improved Functionality with Bright Backlit LCD and 4 Button Operation**  
Combined with a simplified 4 button operation, the Scout's large backlit display increases readability in dim lighting conditions, and makes it easier to view results from across a desk or lab bench.
- **Multiple Connectivity Options Available for Data Logging and Communication**  
With expanded connectivity options including RS232, USB Host, USB Device, Ethernet and Bluetooth<sup>®</sup>, the Scout provides added versatility to your data collection and transfer needs.
- **Fast Weighing Speed and High Resolution Deliver Repeatable and Reliable Results**  
Stabilization time as fast as 1 second means increased efficiency in your classroom. Equipped with advanced weighing technology, the Scout also ensures repeatable and reliable weighing results.

# Scout® Portable Precision Balances

## Scout can Handle Demanding Classroom Environments

The superior mechanical overload protection system of the Scout is comprised of a high-strength stainless steel pan and an impact-resistant plastic pan support. This enables the balance to safely withstand loads up to 10 times its rated capacity, and survive in demanding classroom environments where capacity may be frequently exceeded. Scout's unique stacking and storage cover allows the balance to be safely stored away when not in use. The integrated transportation lock protects the load cell from damage during stacking storage and transportation.



## User-Friendly Experience Guaranteed with Backlit Display and 4-Button Operation

4 clearly marked buttons remove complexity, and guide you quickly and easily through balance setup, unit of measure changes, calibration and more. Poor lighting in the lab or classroom is not an issue with the new Scout. The large, bright backlit LCD display improves readability in conditions where lighting is poor, and makes it easy to see the weighing results from a distance.



## Expanded Connectivity Options Allow for a More Modern Weighing Experience

Scout has multiple connectivity options – RS232, USB Host, USB Device, Ethernet and Bluetooth®. With expanded connectivity options, the OHAUS Scout offers more versatility for convenient data logging, communication and remote functionality. Utilize the Bluetooth accessory to remotely control the balance from your mobile device or tablet for Android™\*. Perform functions such as Zero, Tare, Print, Power Off and more. With the USB Host option, you can simply save and transfer data from the balance to a USB drive.



## Increased Efficiency and Productivity in your Facility

It's all about accuracy and efficiency with the OHAUS Scout balance. Stabilization time as fast as 1 second combined with high resolution deliver extremely precise and repeatable weighing results that you can count on time and time again. This makes the Scout ideal for routine experiments and other weighing applications in your classroom.



Scout shown with optional Density Determination Kit

## Draftshield Model Available

Scout's ingenious draftshield (1mg model only) was designed with an easy to remove top cover piece. This serves as a wind protection ring which keeps the weighing surface stable in rough environments, while maintaining weighing speed.



\*Android is a trademark of Google Inc.



**Stackable Design**  
Space-saving design allows for stackable storage (excludes mg models)



**Connectivity**  
Expanded connectivity options including RS232, USB Host, USB Device, Ethernet and Bluetooth®



**Security Slot**  
Integrated security slot prevents theft



**Weigh Below Hook**  
The integral weigh below hook on the bottom of the Scout allows for density determination or specific gravity calculations



**Lockswitch**  
The Scout can be locked into a specific configuration using the lockswitch

**Large Backlit LCD Display**  
High contrast LCD Display shows weight and application data clearly, even in poor lighting conditions

## Built-in Application Modes

- **Weighing**—Determines the weight of items on the pan in the selected unit of measure.
- **Density Determination**—Determines density of solids or liquid. With the integrated weigh below hook, it is possible to perform specific gravity tests for objects that cannot be easily placed on the weighing pan.
- **Mole Weighing**—Measures the weight of a sample and calculate it into Moles automatically.

## Outline Dimensions

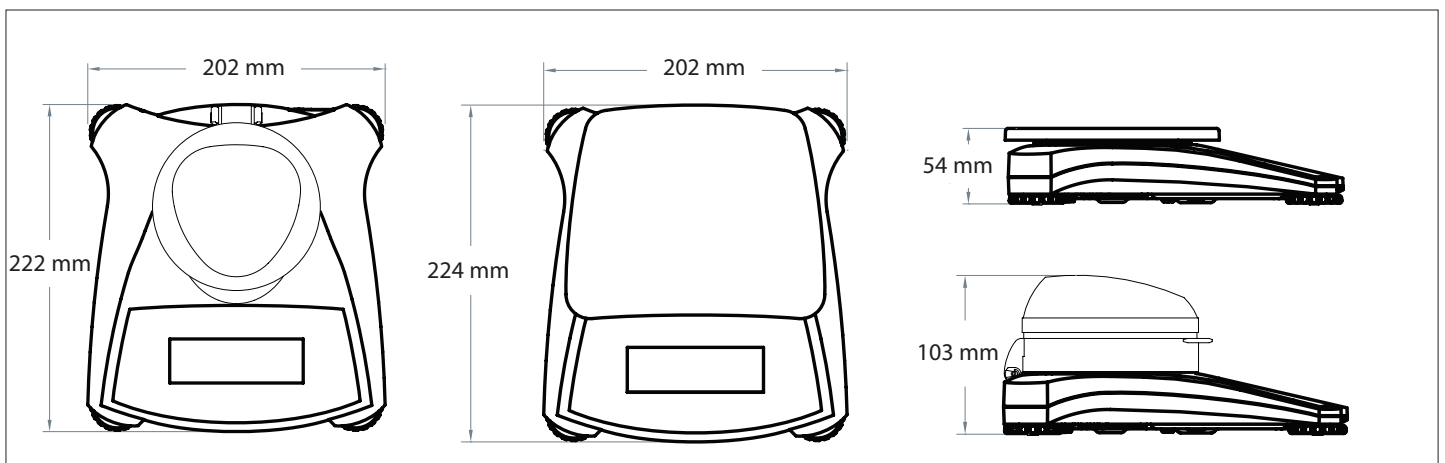

# Scout® Portable Precision Balances

Model	SKX123	SKX222	SKX422	SKX622	SKX1202	SKX2202	SKX421	SKX621	SKX2201	SKX6201	SKX8200	
Capacity (g)	120	220	420	620	1200	2200	420	620	2200	6200	8200	
Readability (g)	0.001	0.01					0.1					1
Repeatability (Std. Dev.) (g)	0.002	0.01			0.02		0.1					1
Linearity (g)	0.003	0.01		0.02	0.03		0.1			0.2	1	
Span Calibration Mass*	100 g	200 g		300 g	1 kg	2 kg	200 g	300 g	2 kg	5 kg	8 kg	
Linearity Calibration Mass*	50, 100 g	100, 200 g	200, 400 g	300, 600 g	500 g, 1 kg	1 kg, 2 kg	200, 400 g	300, 600 g	1 kg, 2 kg	3 kg, 5 kg	4 kg, 8 kg	
Stabilization Time (s)	1.5	1			1.5		1					
Construction	ABS housing & stainless steel pan											
Draftshield	Yes	No										
Calibration	User-selectable external span or linearity calibration/Digital with external weight											
Tare Range	Full capacity by subtraction											
Weighing Units	g, kg, N, oz, lb, lb:oz											
Application Modes	Weighing, Density Determination, Mole Weighing											
Power Requirement	AC adapter (included) or 4 AA batteries (not included)											
Typical Battery Life	80 hours	120 hours	80 hours			120 hours			80 hours	120 hours		
Communication	RS232, USB Host, USB Device, Ethernet or Bluetooth® (available as an accessory)											
Display Type	Liquid crystal display (LCD) with backlight											
Display Size	20 mm digits											
Overload Capacity	10 times rated capacity											
Operating Temperature Range	10°C to 40°C at 10% to 85% relative humidity, non-condensing											
Storage Conditions	-20°C to 55°C at 10% to 90% relative humidity, non-condensing											
Pan Size (W × D)	Ø93 mm	Ø120 mm			170 × 140 mm	Ø120 mm	170 × 140 mm					
Balance Dimensions (W × D × H)	202 × 222 × 103 mm	202 × 224 × 54 mm										
Shipping Dimensions (W × D × H)	300 × 250 × 129 mm											
Net Weight	1 kg											
Shipping Weight	1.6 kg											

\* Calibration weights are included with models up to 620g capacity.

## Other Standard Features and Equipment

Transportation lock, stainless steel pan, menu & calibration lockout switch, mechanical and software overload/underload protection, stability indicator, auto tare, low battery indicator, auto shut-off, user-selectable printing options, user-selectable communication settings

## Compliance

- **Product Safety:** IEC/EN 61010-1; CAN/CSA C22.2 No. 61010-1; UL Std. No. 61010-1
- **Electromagnetic Compatibility:** IEC/EN 61326-1 Class B; FCC Part 15 Class B; Industry Canada ICES-003 Class B

## Accessories

RS232 Interface Kit . . . . .	30268982
USB Host Interface Kit . . . . .	30268983
USB Device Interface Kit . . . . .	30268984
Bluetooth Interface Kit . . . . .	30268985
Ethernet Interface Kit . . . . .	30268986
Stacking & Storage Cover (6 pcs) . . . . .	30268987
Stacking & Storage Cover (1 pc) . . . . .	30268988
Printer, Impact, SF40A, EU . . . . .	30064202
Auxiliary Display Kit . . . . .	30269019
Security Device . . . . .	80850043
Top Loading Kit for Density Determination . . . . .	30269020
Carrying Case . . . . .	30269021
In-use Cover . . . . .	30269022

**OHAUS Europe GmbH**  
 Im Langacher 44  
 8606 Greifensee  
 Switzerland

e-mail: [ssc@ohaus.com](mailto:ssc@ohaus.com)  
 Tel: 0041 22 567 53 19  
 e-mail: [tsc@ohaus.com](mailto:tsc@ohaus.com)  
 Tel: 0041 22 567 53 20

[www.ohaus.com](http://www.ohaus.com)

OHAUS Corporation is an ISO 9001:2008 manufacturer

ISO 9001:2008  
 Registered Quality  
 Management System

Europe Literature #

