

3-DOOR SLIM LOCKER

Assembly Instructions

3-Casier étroit à 3 portes

Instructions de montage

Armario delgado de 3 Puertas

Instrucciones de montaje



THIS MANUAL CONTAINS IMPORTANT INFORMATION REGARDING SAFETY, OPERATION, MAINTENANCE AND STORAGE OF THIS PRODUCT. BEFORE USE, READ CAREFULLY AND UNDERSTAND ALL CAUTIONS, WARNINGS, INSTRUCTIONS AND PRODUCT LABELS. FAILURE TO DO SO COULD RESULT IN SERIOUS PERSONAL INJURY AND/OR PROPERTY DAMAGE.

CE MANUEL CONTIENT DES INFORMATIONS IMPORTANTES CONCERNANT LA SÉCURITÉ, LE FONCTIONNEMENT, L'ENTRETIEN ET LE REMISAGE DE CE PRODUIT. LIRE, ÉTUDIER BIEN COMPRENDRE TOUTES LES MISES EN GARDE ET INSTRUCTIONS ET AUTOCOLLANTS APOSÉS SUR LE PRODUIT AVANT DE L'UTILISER. NE PAS RESPECTER CES INSTRUCTIONS POURRAIT ENTRAÎNER DES BLESSURES ET/OU DES DOMMAGES MATÉRIELS.

ESTE MANUAL CONTIENE INFORMACIÓN IMPORTANTE SOBRE LA SEGURIDAD, OPERACIÓN, MANTENIMIENTO Y ALMACENAMIENTO DE ESTE PRODUCTO. ANTES DE USARLO, LEA CUIDADOSAMENTE Y COMPRENDA TODAS LAS PRECAUCIONES, ADVERTENCIAS, INSTRUCCIONES Y ETIQUETAS DEL PRODUCTO. DE LO CONTRARIO PODRÍA SUFRIR LESIONES GRAVES O CAUSAR DAÑOS MATERIALES.

⚠ WARNING

- READ ALL INSTRUCTIONS BEFORE ASSEMBLY. Follow all warnings and safety precautions. If the installation is not performed correctly, the unit could fall off the wall and cause serious injury or death.
- Always use appropriate safety equipment when using power and hand tools. Failure to do so may cause personal injury or product damage.
- Use adequate manpower when assembling this unit. Failure to do so may cause personal injury or product damage.
- DO NOT alter this product in any manner.
- Secure to the wall with supplied hanging bracket.
- Make sure that the wood screws are screwed at least 38 mm / 1-1/2 inches deep into solid wood or framing material or into at least 12.7 mm / 1/2 inch thick wallboard using wall anchors. Failure to do so could result in the wall unit falling off the wall.
- Know the location of all utility lines before drilling. Serious injury or even death may occur if you accidentally drill into a utility connection (gas, water, electric). Make sure you shut off the power to all electrical lines and outlets that you may come into contact with during installation by shutting off the circuit breaker/fuse at the electrical panel. Use a circuit tester to make sure the power is off.
- DO NOT overload top lockers to reduce risk of tipping.
- Place heavier items on bottom lockers.

⚠ AVERTISSEMENT

- LIRE TOUTES LES INSTRUCTIONS AVANT LE MONTAGE. Respecter toutes les mises en garde et consignes de sécurité. Si l'installation est mal réalisée, l'unité peut se décrocher du mur et provoquer de graves blessures corporelles ou la mort.
- Toujours utiliser un équipement de sécurité adapté avec des outils électriques et manuels. Le non-respect de ces consignes peut entraîner des blessures corporelles ou endommager le produit.
- Ne pas hésiter à se faire aider, si nécessaire, pour assembler cette unité. Le non-respect de ces consignes peut entraîner des blessures corporelles ou endommager le produit.
- NE PAS altérer ce produit d'une quelconque façon.
- Fixer sur le mur à l'aide du crochet de suspension.
- S'assurer que les vis à bois sont vissées sur au moins 38 mm / 1,5 pouce de profondeur dans du bois plein ou un matériau d'encadrement, ou d'au moins 12,7 mm / 1/2 pouce dans un panneau mural épais si l'on utilise des ancrages au mur. Dans le cas contraire, l'unité murale pourrait se décrocher du mur.
- Repérer la position de tous les câbles de service public ou canalisations avant de percer. De graves blessures, parfois mortelles, peuvent survenir si l'on perce accidentellement un raccord de service public (gaz, eau, électricité). S'assurer que toutes les lignes et prises électriques ne sont plus sous tension pour éviter tout contact accidentel avec le courant pendant l'installation en coupant le disjoncteur/fusible au tableau électrique. Utiliser un multimètre pour vérifier que le courant est bien coupé.
- NE PAS surcharger les casiers supérieurs pour éviter de faire basculer l'armoire.
- Placez les objets les plus lourds dans les casiers inférieurs.

⚠ ADVERTENCIA

- LEA TODAS LAS INSTRUCCIONES ANTES DEL MONTAJE. Acate todas las advertencias y precauciones de seguridad. Si la instalación no se realiza correctamente, la unidad podría caer de la pared y causar lesiones graves o letales.
- Siempre use equipo de seguridad apropiado cuando emplee herramientas manuales y eléctricas, de lo contrario podría causar lesiones o daños materiales.
- Use mano de obra adecuada durante el montaje de esta unidad, de lo contrario podría causar lesiones o daños materiales.
- NO altere este producto en modo alguno.
- Afíncelo a la pared con el soporte para colgar que se proporciona.
- Cerciórese de introducir los tornillos para madera por lo menos a 38 mm / 1-1/2 pulgadas de profundidad en madera maciza o material de enmarcado, o en paneles de yeso de al menos 12,7 mm / 1/2 de pulgada de grosor si va a usar anclajes de pared. De lo contrario la unidad podría caer de la pared.
- Conozca la ubicación de todas las líneas de servicios públicos antes de perforar. Puede sufrir lesiones graves o incluso letales si perfora accidentalmente una conexión de servicio público (gas, agua, electricidad). Cerciórese de apagar el suministro de todas las líneas y tomacorrientes eléctricos con los cuales pueda hacer contacto durante la instalación apagando el cortacircuito/fusible en el panel eléctrico. Use un probador de circuito para asegurarse de que el suministro esté apagado.
- NO sobrecargue los armarios superiores para reducir el riesgo de vuelco.
- Coloque los elementos más pesados en los armarios inferiores.

Tools Needed / Outils requis / Herramientas necesarias



40 Min



#2

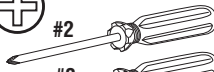

#3

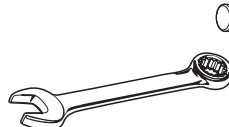

10 mm / 0.39 in./po./pulg.



2.7 mm / 7/64 in./po./pulg.



9.5 mm / 3/8 in./po./pulg.

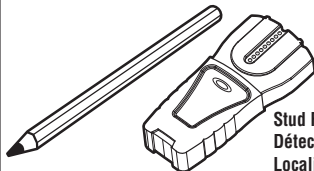

Stud Finder
Détecteur de montant
Localizador de vigas



Parts / Pièces / Partes

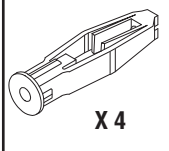
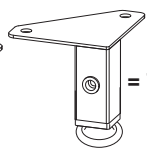
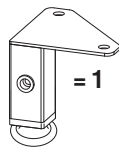
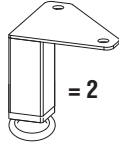
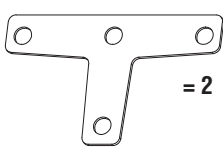
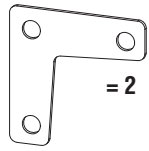
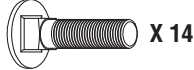
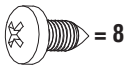
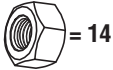
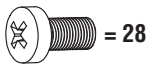

Optional for Stacking / En option pour empiler les unités /
Optativos para apilar

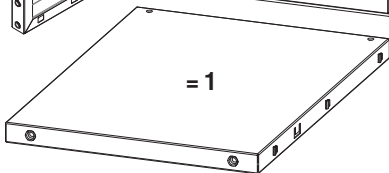
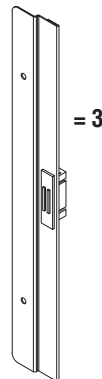
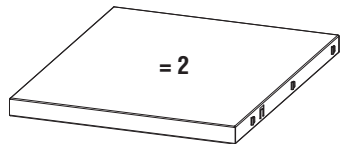
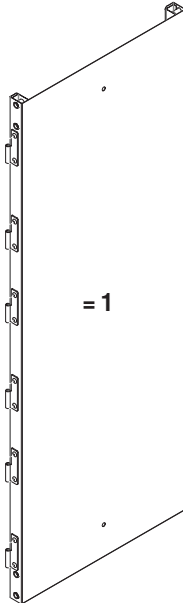
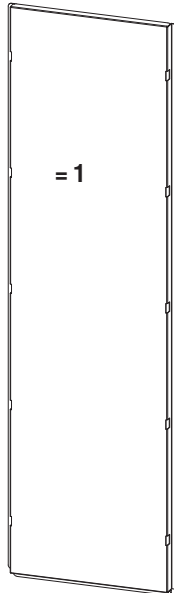
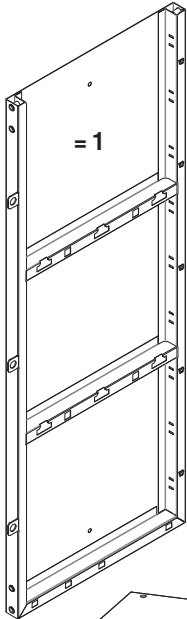
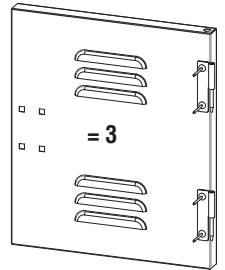
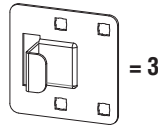
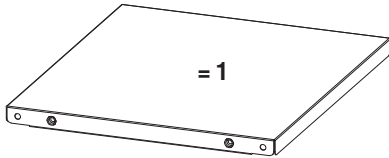
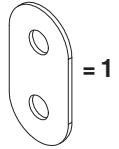
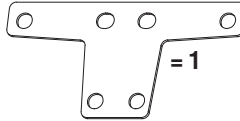
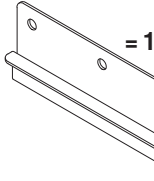
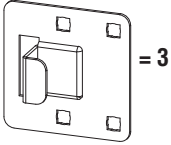

Please Note:

When assembling unit, please be aware of interlocking channels and grooves on parts. These grooves slide into channels as shown.

À noter :

Lors de l'assemblage de l'unité, faire attention à l'emboîtement des coulisses et des rainures sur les pièces. Ces rainures se glissent dans les coulisses comme illustré.

Nota:

Al montar la unidad, tenga en cuenta las salientes y surcos de interbloqueo en las partes. Estos surcos se deslizan en las salientes tal como se muestra.

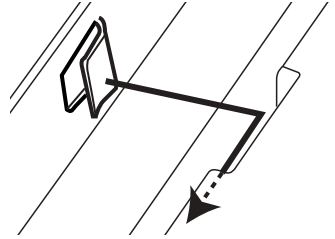

1

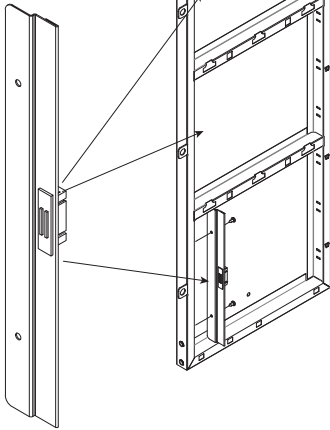
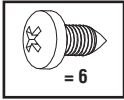

2

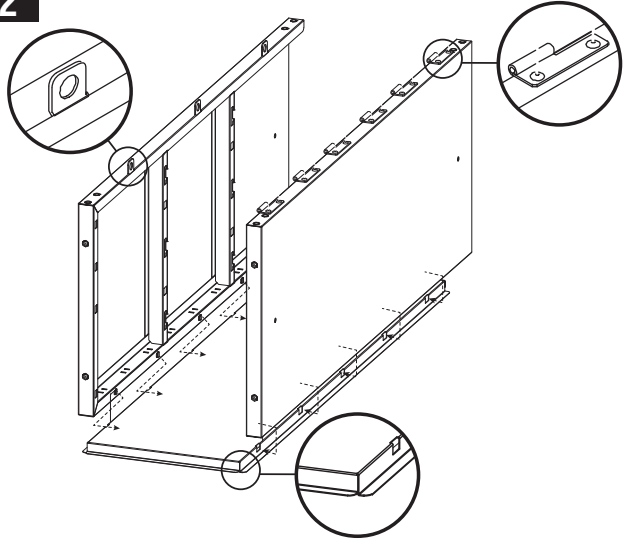

3

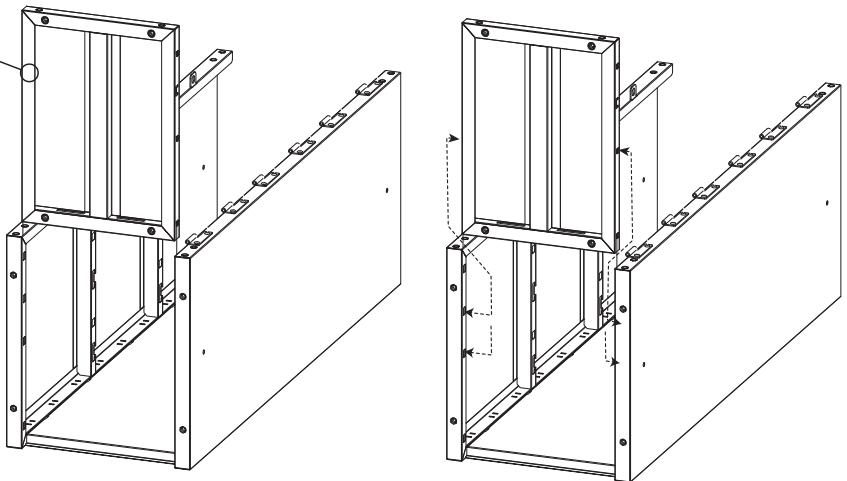

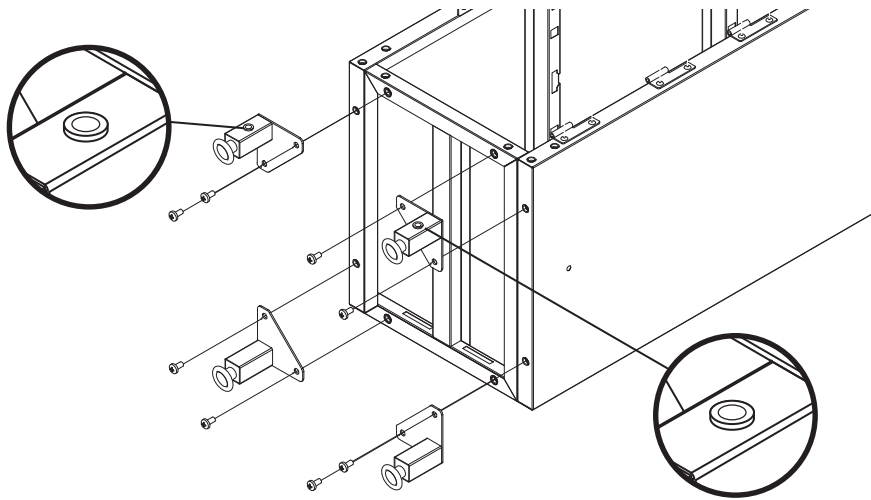
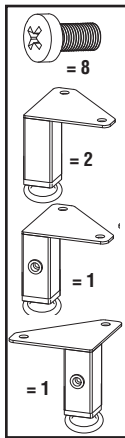
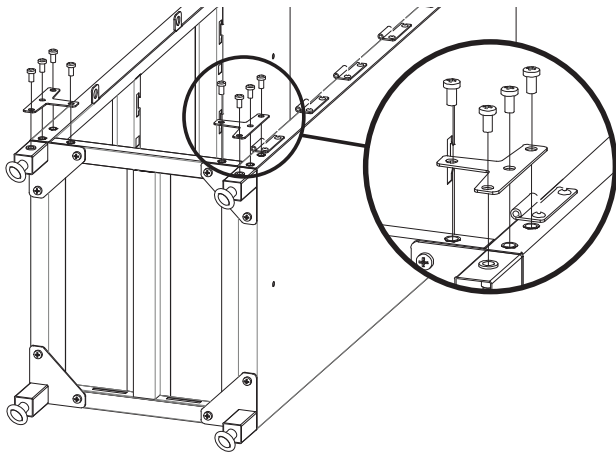
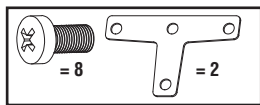
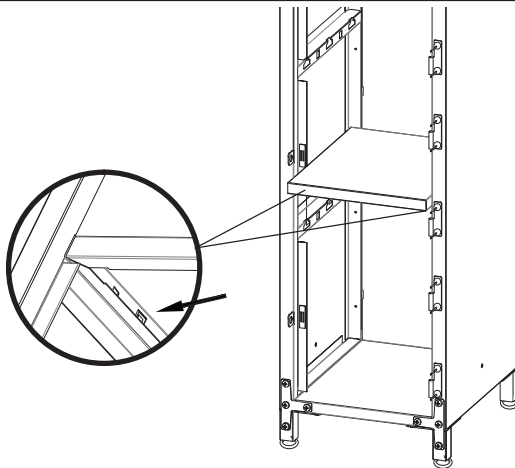
4**5****6**

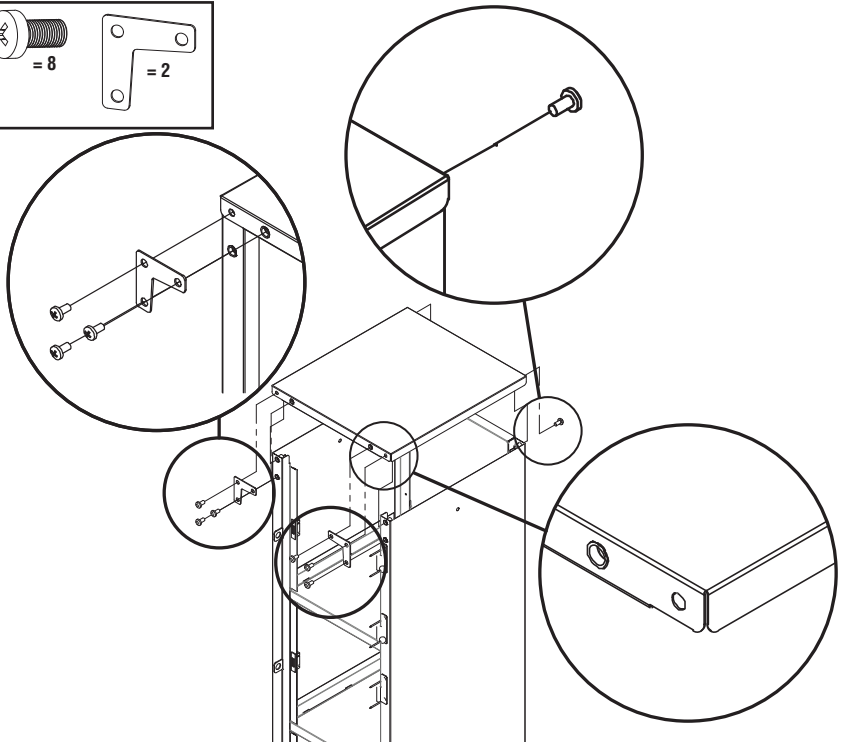
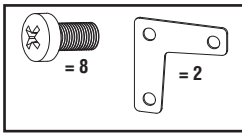
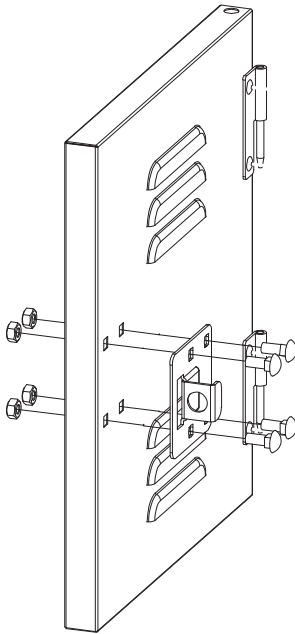
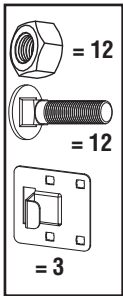
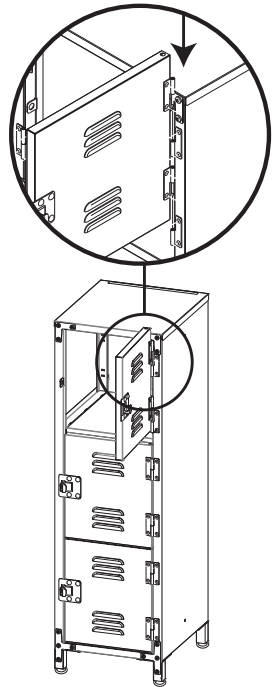
7**8****9**

Securing Locker / Fixation du casier / Fijación de Armario

IMPORTANT!

Locker must be secured to a wall to prevent from tipping over. Failure to do so may cause serious injury.

Locker is not meant to hang on wall.

Make sure that the wood screws are screwed at least 38 mm / 1-1/2 inches deep into solid wood or framing material or into at least 12.7 mm / 1/2 inch thick wallboard using wall anchors. Failure to do so could result in the wall unit falling off the wall.

IMPORTANT!

Le casier doit être solidement fixé à un mur pour l'empêcher de basculer. Le non-respect de cette consigne peut provoquer de graves blessures. Le casier n'est pas conçu pour être suspendu à un mur.

S'assurer que les vis à bois sont vissées sur au moins 38 mm / 1,5 pouce de profondeur dans du bois plein ou un matériau d'encadrement, ou d'au moins 12,7 mm / 1/2 pouce dans un panneau mural épais si l'on utilise des ancrages au mur. Dans le cas contraire, l'unité murale pourrait se décrocher du mur.

¡IMPORTANTE!

El armario debe fijarse a una pared para impedir que se vuelque, de lo contrario puede causar lesiones graves.

El armario no está diseñado para colgarlo en la pared.

Cerciórese de introducir los tornillos para madera por lo menos a 38 mm / 1-1/2 pulgadas de profundidad en madera maciza o material de enmarcado, o en paneles de yeso de al menos 12.7 mm / 1/2 pulgada de grosor si va a usar anclajes de pared. De lo contrario la unidad podría caer de la pared.

Stud Mount: (Drywall mount on next page) / Installation sur un montant : (Installation sur cloison sèche page suivante)

Montaje en viga: (Montaje en pared seca en la página siguiente)

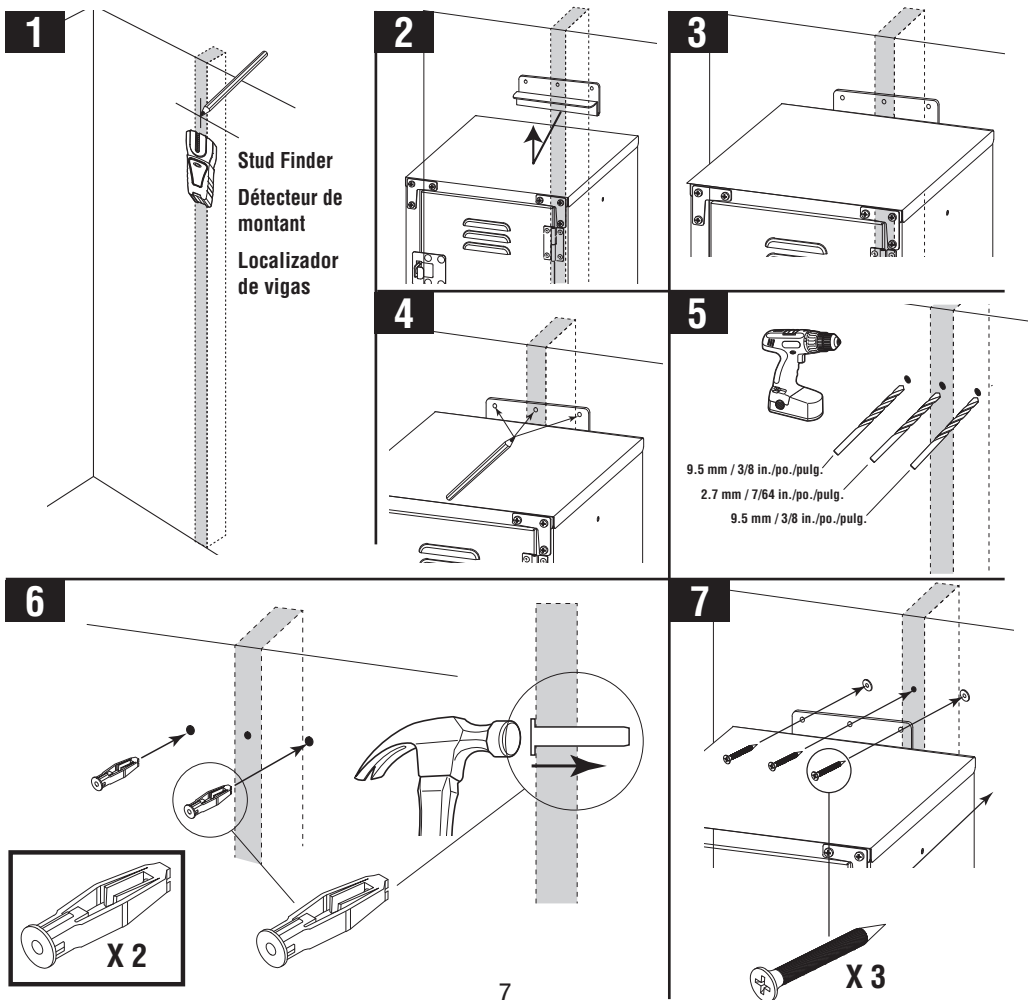

Drywall Mount / Installation sur cloison sèche / Montaje en pared seca:

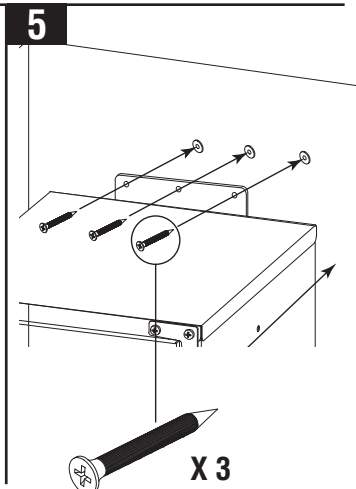
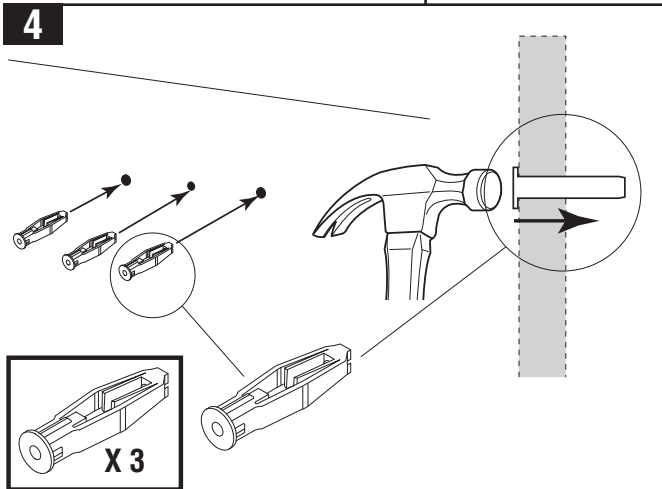
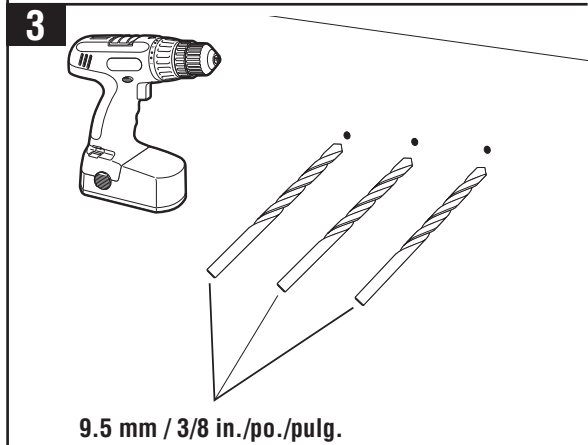
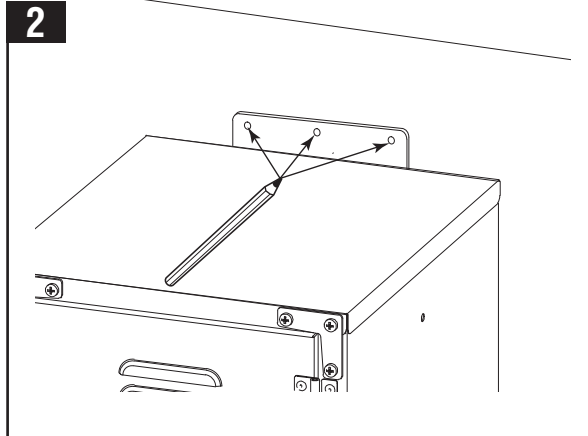
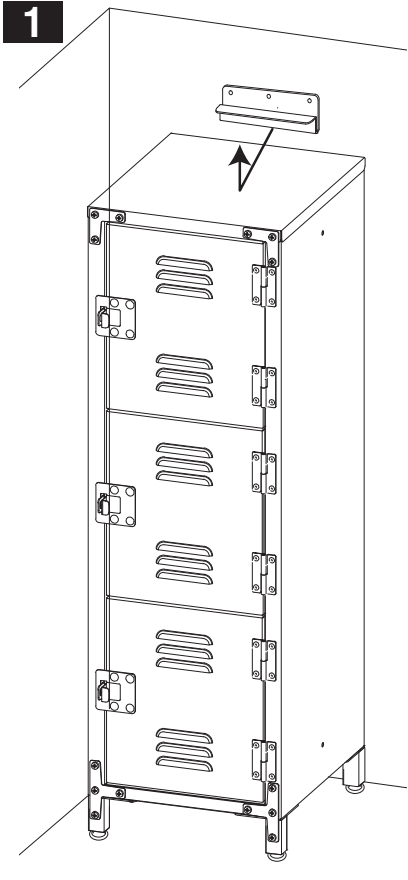

Stacking 2 Units (Optional) / 2 unités empilées (en option) / Apilado de 2 unidades (optativo)

1

Top Unit / Unité supérieure / Unidad Superior

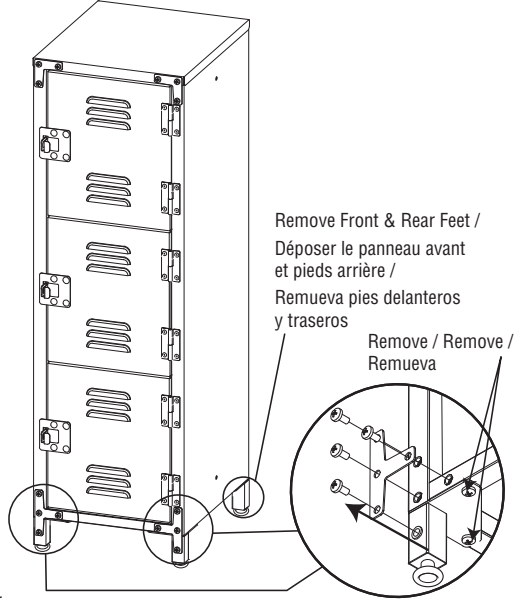
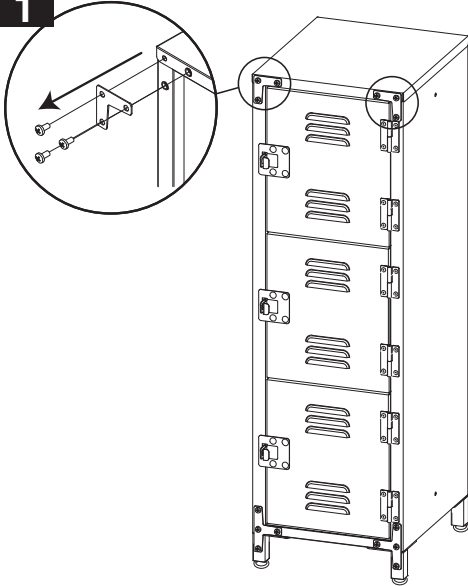

Remove Front & Rear Feet /
Déposer le panneau avant
et pieds arrière /
Remueva pies delanteros
y traseros

Remove / Remove /
Remueva

Bottom Unit / Unité inférieure / Unidad Inferior

2

Front / Devant /
Adelante

Back / Dos /
Atrás

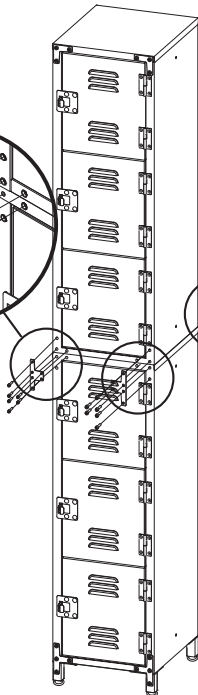
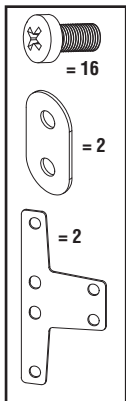

3

**See Securing Locker section.
Voir section Fixation du casier.
Consulte la sección de fijación
del armario.**

Securing Side by Side (Optional) / Fixation en côte à côte (en option) / Lado a lado (optativo)

1

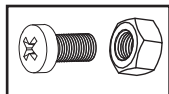

Holes on sides of locker for securing side by side.

Trous sur les côtés du casier pour sécuriser l'installation en côte à côte.

Orificios en los lados del armario para fijación lado a lado.

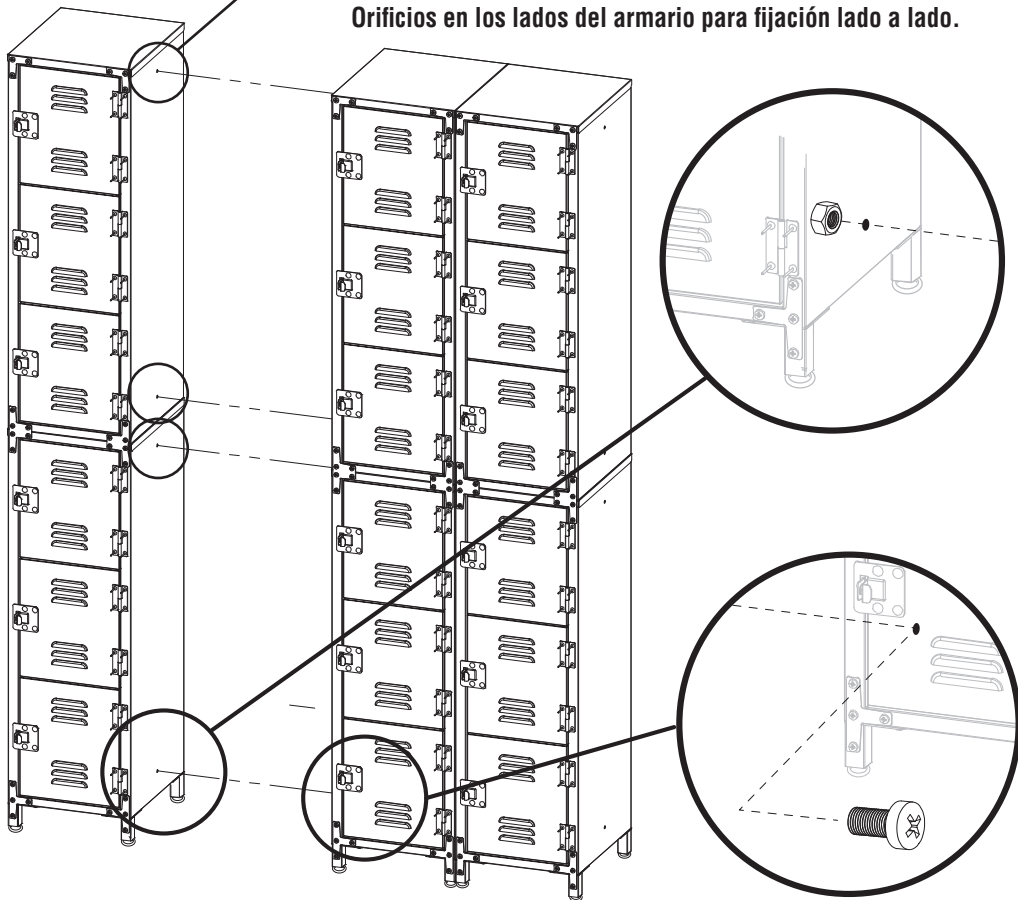

2

See Securing Locker section.

Voir section Fixation du casier.

Consulte la sección de fijación del armario.



Alltrade Tools LLC • 1431 Via Plata, Long Beach, CA 90810-1462 USA • www.alltradetools.com
Made in China / Fabriqué en Chine / Hecho en China • © Copyright 2016 Alltrade Tools LLC.