



K-LINE® Irrigation Farm Packs

3 Pod, 4 Pod and 5 Pod Farm Packs

with 32mm K.PIPE® and Naan 5022 Sprinklers

Installation and user manual



STEP 1: View the K-LINE® Installation Video

Please review the K-LINE® Installation video on the USB drive to become familiar with the K-LINE® System.



STEP 2: Identify System Components

<p>32mm Tapping Saddle (1) KLTPS32</p> <p>Sprinkler w/Red Nozzle (1) NAAN5022SD-RED</p> <p>Sprinkler Adaptor (1) NAAN-ADAPTOR</p> <p>K-LINE® Pod (1) KLSTD.POD</p> <p>Brass Nuts (2) KLSP-BRASS NUT</p> <p>Black & Orange Nozzles* (1 each) NOZZ5022-BLK NOZZ5022-ORG</p> <p><small>*Alternative nozzles for sprinkler</small></p>	<p>3 Pod Pack 32mm K.PIPE® x 66m K.PIPE32.066</p> <p>or</p> <p>4 Pod Pack 32mm K.PIPE® x 76m K.PIPE32.4PP.076</p> <p>or</p> <p>5 Pod Pack 32mm K.PIPE® x 115m K.PIPE32.5PP.116</p> <p>or</p> <p>Farm Pack 32mm K.PIPE® x 100m K.PIPE32FP.100</p>	<p>Female Threaded Adaptor (1) CAM32A</p> <p>Female Threaded Coupling (1) CAM32D</p> <p>32mm Hex Nipple (1) RXHN32</p> <p>Tow Cap (1) RXTC32</p> <p>PTFE Thread tape (1) CT</p> <p>Male Coupling (3) KLMC32</p> <p>Straight Coupling (1) KLSC32</p> <p>Rope (2 m.) KL-ROPE</p> <p>Installation USB (1) USB.KLFPACK</p> <p>13mm metric deep socket x 3/8" (1) KLTL.3.8.13SOCKET</p> <p>14mm Spade bit w/limiter x 13mm Hex (1) KLTL14.DRILL</p> <p>Drill head Adaptor 3/8" drive x drill head (1) KLTL.DRILL.ADAP</p>
--	---	--

(3 Pod pack = 3 x value shown)
(4 Pod pack = 4 x value shown)
(5 Pod or Farm Pack = 5 x value shown)

(select pipe from your pack)

(standard components in each pack)

STEP 3: Tools That May Assist With Installation

Adjustable pipe wrench	Large channel lock pliers	Rubber mallet	3/8" Ratchet wrench	Socket extension 3/8" x 150mm KLTL3.8.150EXTN	Tie-down hook & rope (optional)
Cordless drill	1 1/4" to 2" poly pipe cutters (or hacksaw)	Water	Measuring wheel or 50m tape(s)	Marker flags or tent pegs	20mm wrench (optional)
					30mm wrench (optional)

STEP 4: K-LINE® System Overview

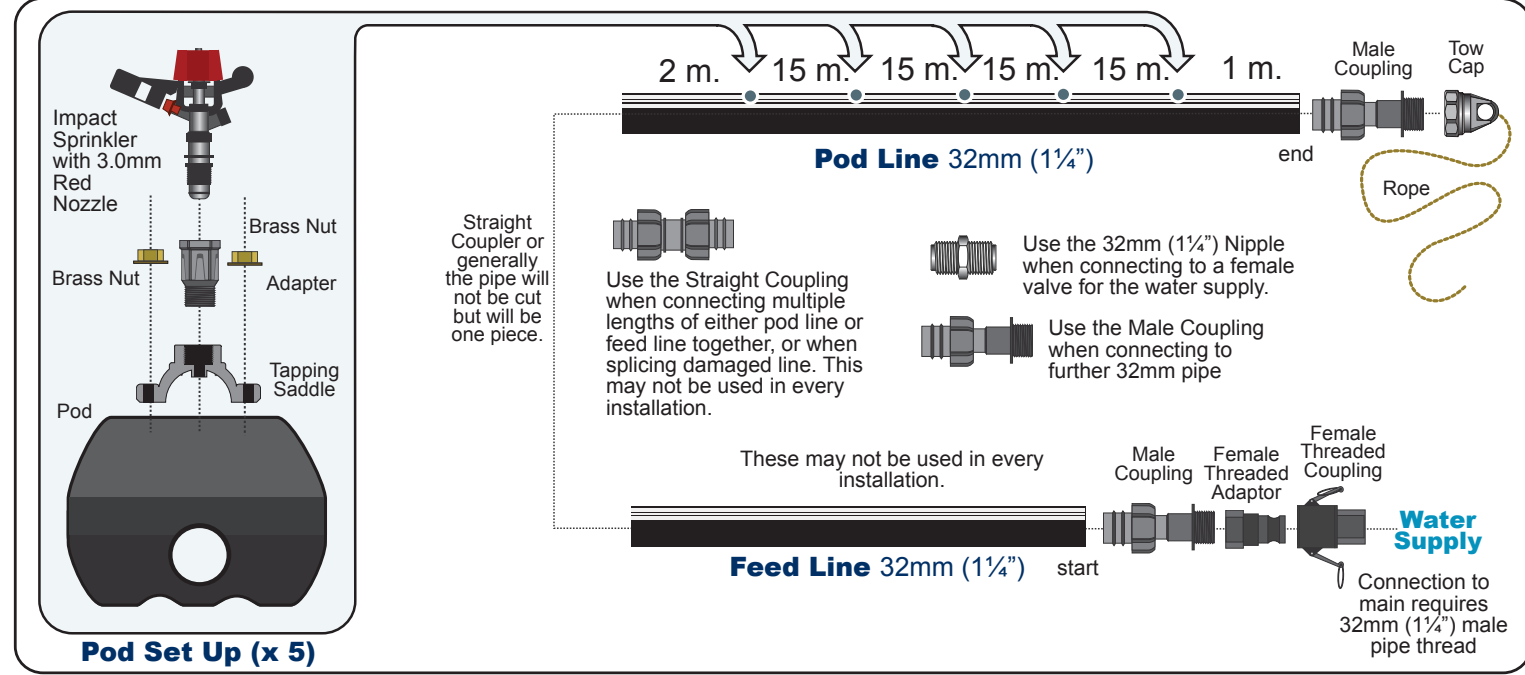

STEP 5: Plan your Irrigation System Layout *

Field shapes and dimensions may not match this ideal layout. K-LINE's signature flexibility allows for adaptation to other field dimensions. See the additional "Sample Designs" at the end of this manual.

A

Determine the area of the field to be irrigated. Up to approx. 1.0 hectares.

B

Determine the center of the field. This is the location of the riser.

C

Determine the supply line route from the water supply to the center of the field. The water supply line should be 32mm (1¼") or larger from the water source, beginning at a point where sufficient flow rate and pressure are available.

Water Supply
2,500-5,250 litres per hour
@ 250kPa - 350kPa
Varies depending on nozzle size

D

Consider your supply line. Supply line options include:

1. Buried (underground) PVC or polyethylene plastic pipe.
2. Lay-flat tubing (above ground), similar to fire hose, available from your irrigation dealer.
3. K.PIPE® Irrigation tubing (above ground). K.PIPE® is highly durable and specifically formulated to remain flexible, is freeze resistant, and has excellent UV resistance.

E

K-LINE's great flexibility of design allows for numerous options in laying out a field. K-LINE® is adaptable in its ability to have more than one riser location. Sprinkler/pod lines can be curved to adjust to field shapes, obstacles, or terrain. Sprinkler nozzles are easily changed for adjusting application rates. Shifting more than once per day allows a larger area to be covered quickly. Extended irrigation sets can apply that long, slow rain that fills the soil profile and encourages a stronger, deeper and more efficient, and resilient, root system.

We have included many examples in our "Sample Designs" that are included in this kit to help identify irrigation opportunities for your situation. Call your K-LINE® supplier for any questions.

Determine Shift/Set Widths.
Shift/Set widths are recommended to be between 12 m. and 15 m.

The material included in a 5 pod kit allows for a field length of up to 150 m.

F

Once a field design has been decided and the riser location(s) have been located, another consideration is the placement of markers at the ends of the area to be irrigated to aid in shifting the K-LINE®.

Placement of markers at the end of the field (in the center of each Set width – see the Diagram to the right) gives the operator a target to aim for when shifting the K-LINE® (especially beneficial when becoming accustomed to shifting the K-LINE® or in irregularly shaped fields).

Markers are often brightly colored (fluorescent yellow, orange, or red) markers that can be attached to a fence; that offer excellent visibility.

STEP 6: K-LINE® Irrigation Layout of the Pod Line

A Rolling out the Pod Line

Roll out the 32mm tubing 3-4 m. past the final marker to keep the end from rolling back during pod installation.



DO NOT ALLOW IT TO TWIST! The triple white line should face up for the entire length of the tubing.

***Hint:** It helps to put a heavy object on the ends of the K-LINE® Tubing when rolling it out to keep the tubing in place and prevent it from rolling up behind you. The tubing will relax once rolled out and allowed to sit in the sun.

B Measuring pod placement

Using the measuring wheel or tape, mark out the pod positions with flags or tent pegs and confirm the pod positions.



Note: Sprinkler/pod spacing is determined by field length and may differ if your area to be irrigated is less than 130m, (5 pod pack). For your K-LINE® Pod Irrigation Kit, recommended spacing up to, but not more than 15m. Dealer engineered K-LINE® layouts are usually between 12m and 15m.

If you need assistance, call your supplier or contact RX Plastics sales@rxplastics.co.nz.

STEP 7: Placing the pods

A Slide the pods onto the K.PIPE® tubing.

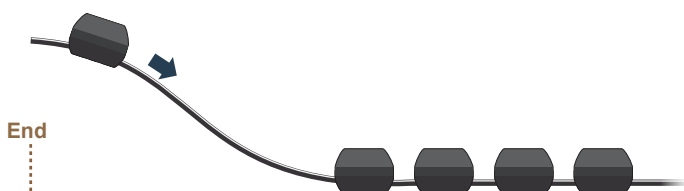

B Use the Tow Rope and Hook to pull all of the pods to the first marker. Unhook a pod, leaving it at the marker.

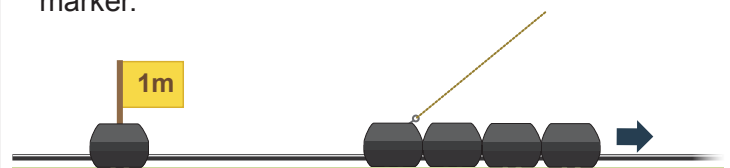

C Continue on to the remaining markers, leaving a pod at each.

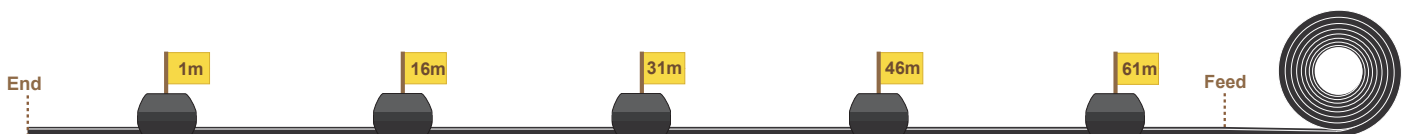

STEP 8: Tapping Saddle Installation

A Install the included K-LINE® spade drill bit w/limiter into a 13mm deep socket, extension and drill adaptor into a cordless drill.

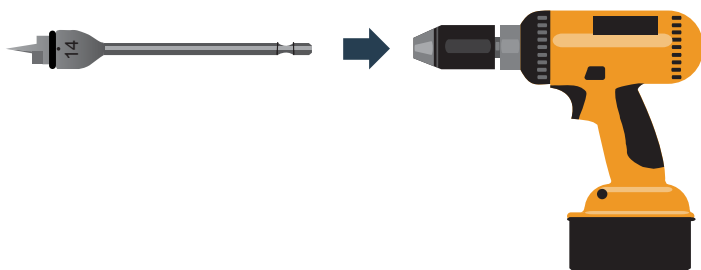

B The hole to be drilled should be on the centre white line in the tubing.

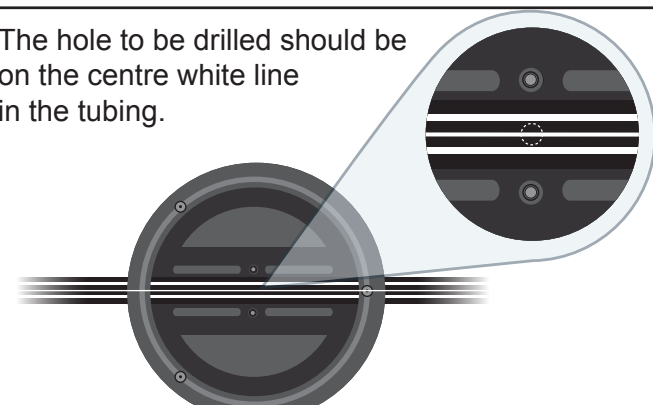

C Drill a 14mm hole in the tubing at the desired spacing.

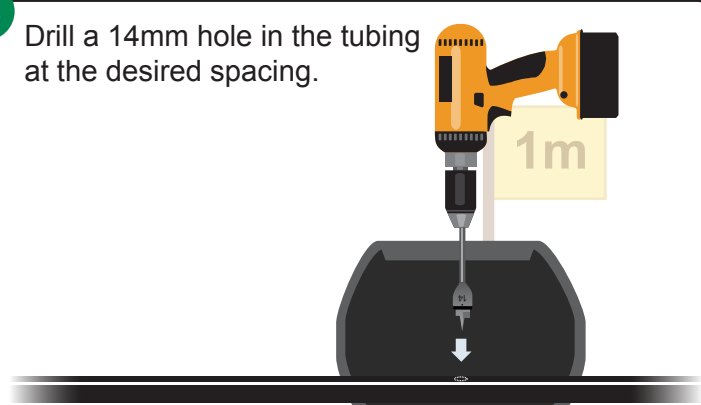

D **Caution: Do not use a 3rd party drill bit.** The K-LINE® Bit has a limiter attached to it to prevent the bit from being inserted too deeply and puncturing the opposite tubing wall.

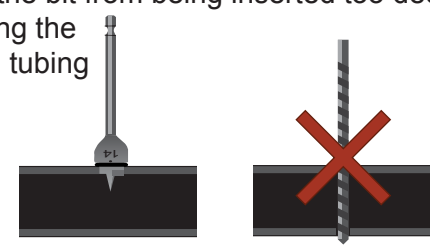

E Center the pod and the two stainless steel threaded posts with the 14mm hole.

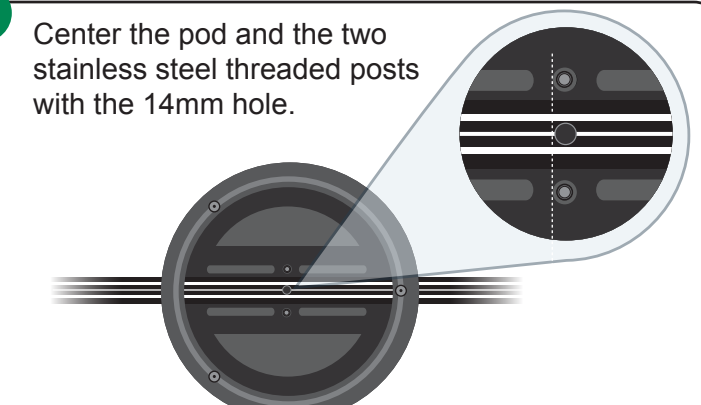

F Make sure that the rubber O-ring is in the groove on the underside of the K-LINE® Tapping Saddle.

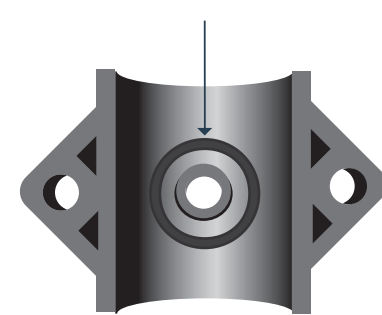

G Push the K-LINE® tapping saddle down over the threaded posts and be certain that the nipple on the underside of the tapping saddle is inserted into the 14mm hole.

The K-LINE® tapping saddle should sit snugly over the tubing without a gap.

A gap might indicate that you are pinching the tubing on either side of the hole causing water to spray out into the pod during operation.

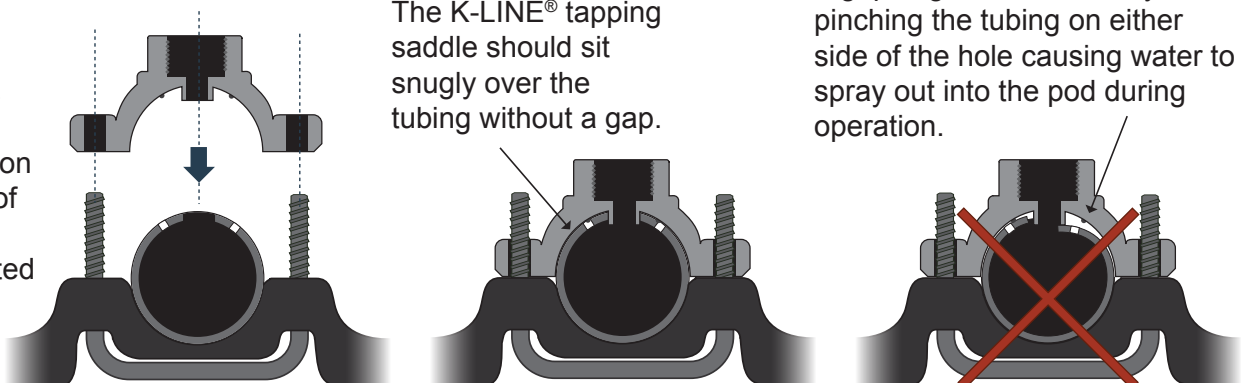

STEP 8: Tapping Saddle Installation (continued)

H

Hand tighten a 8mm brass flange nut onto each post.

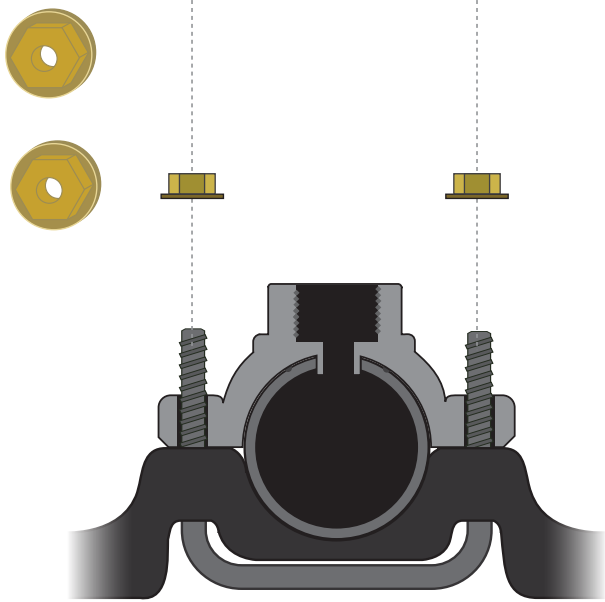

I

With a 13mm socket (with 150mm or longer extension) and ratchet or speed brace alternate tightening the 8mm nuts by switching back and forth several times to make sure that the Tapping Saddle is set level and square.

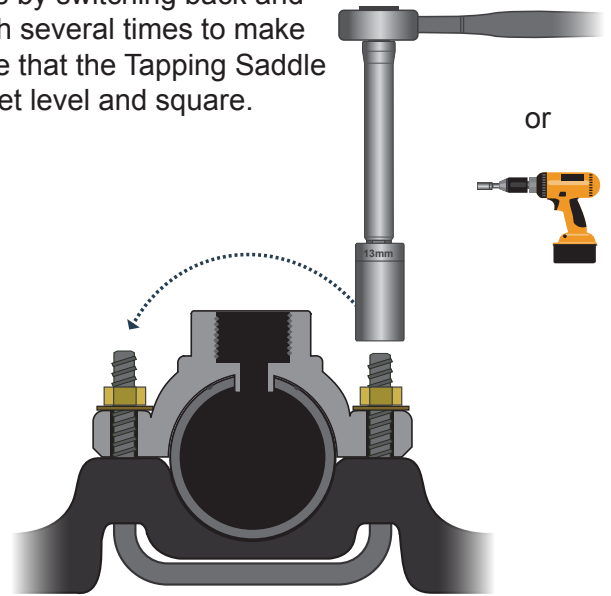

STEP 9: Impact Sprinkler Installation

A

Hand start the adaptor into the K-LINE® tapping saddle (careful not to cross thread), then finish tightening with an adjustable wrench or channel lock pliers.

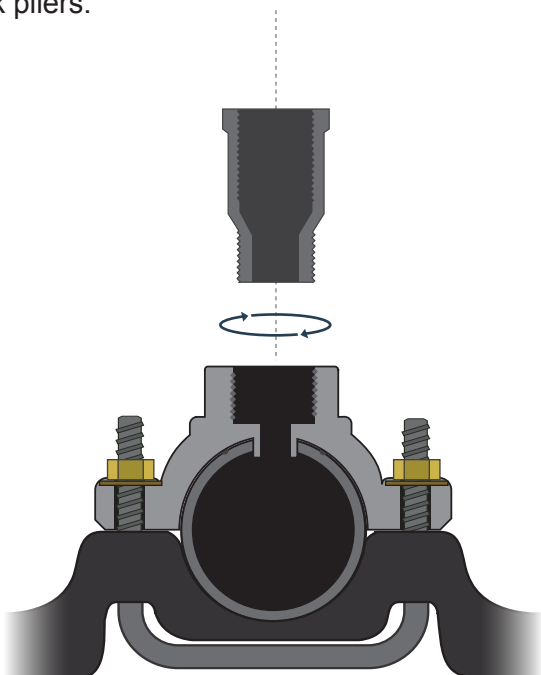

B

Hand start the impact sprinkler (careful not to cross thread), then finish tightening with a 20mm open ended wrench or channel lock pliers.

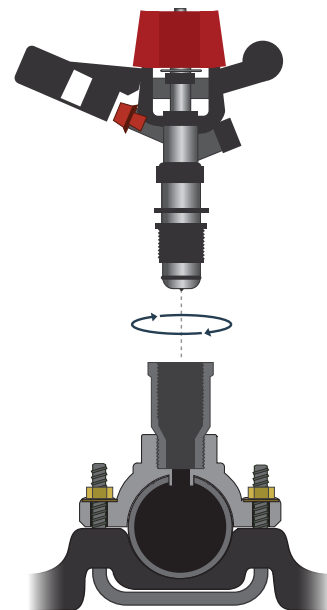

Repeat Steps 8 and 9 for each pod in the line.

STEP 10: K-LINE® Fittings Installation onto the Lines

A

Attach the Male Coupling and Tow cap to the end of the Pod Line, as follows:

① Assemble the Male Coupling and Tow cap together, and tighten with a pipe wrench and channel locks.*

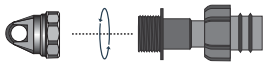

② Moisten the barbed end of the Male Coupling with water. Drive the Male Coupling and Tow cap into the K.PIPE® Tubing with a rubber mallet ensuring that the collar is back against the neck of the Male Coupling.

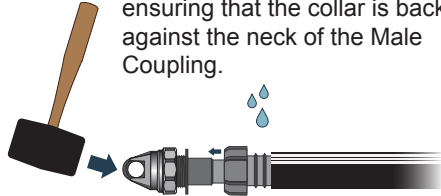

③ Hand tighten the collar of the Male Coupling onto the tubing, then finish by using a combination of pipe wrenches and channel locks to securely tighten the collar. This causes the barbs to bite into the interior and exterior of the K.PIPE® tubing for a strong connection.

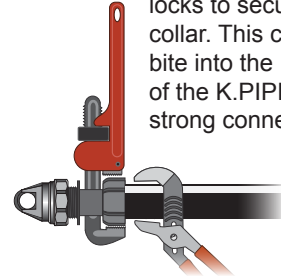

B

Roll out the remainder of the 32mm tubing, this will be the **Feed Line**. In a 5 pod system it should be approximately 35m if your area to be irrigated is 60m wide. If your area to be irrigated is less than 60m, then the **Feed Line** should be at least long enough to run from the riser in the center of the field to the edge of the field.

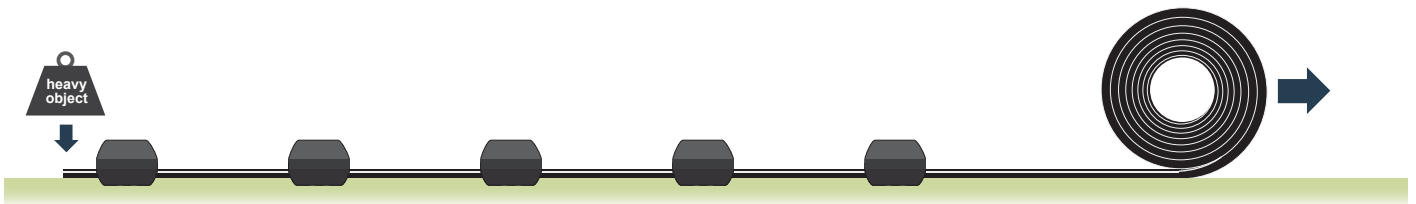

C

Attach the Male Coupling and Female Threaded Adaptor to the Start of the **Feed Line**, as follows:

① Assemble the Male Coupling and Tow cap together, using thread tape on the threads to seal the connection, and tighten with a pipe wrench and channel locks.

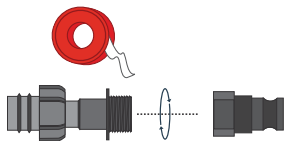

② Moisten the barbed end of the Male Coupling with water. Drive the Male Coupling and Tow cap into the K.PIPE® Tubing with a rubber mallet ensuring that the collar is back against the neck of the Male Coupling.

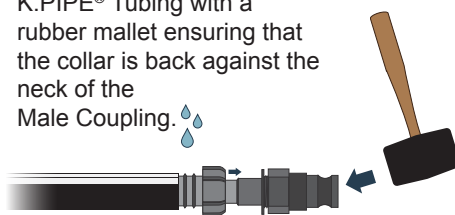

③ Hand tighten the collar of the Male Coupler onto the tubing, then finish by using a combination of pipe wrenches and channel locks to securely tighten the collar. This causes the barbs to bite into the interior and exterior of the K.PIPE® tubing for a strong connection.

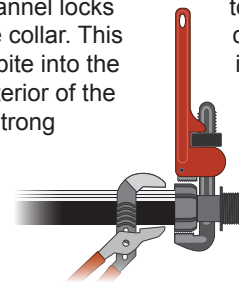

D

Attach the Camlock Female Threaded Adaptor to the Water Supply Line using the supplied Camlock Female Threaded Coupling.

This completes the K-LINE® installation.

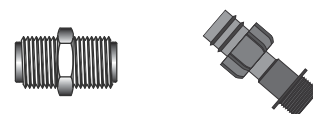
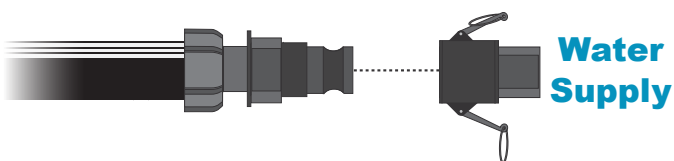

Also supplied is a 32mm nipple and 32 male coupling to assist with connection to your water supply.

Shifting from Set 1 to Set 2

You can shift K-LINE® Irrigation with an ATV, heavy duty lawn tractor, golf cart, Gator, or similar tow vehicle. The preferred method of movement is while the sprinklers are in operation. This saves shifting time and the water pressure in the K.PIPE® tubing helps prevent kinking.

The two most important practices to follow when shifting:

1. **ALWAYS Shift on the "dry" side.** Always begin the shifting procedure on the dry (unirrigated) side of the K-LINE®. The "dry" (unirrigated) side of a K-LINE® is the side next to the section(s) of the field that have not been irrigated. This is opposed to the "wet" (irrigated) sections or "Sets" which have been irrigated previously. This will prevent "double loops" in the Feed Line and reduce chances that the tubing will get kinked. Please refer to the illustrations below and note that the "wet" (irrigated) and "dry" (unirrigated) Sets have been labeled.

2. **When connecting to the K-LINE®** always face towards mid-field and position the tow vehicle 2 - 2.5m from, and parallel to, the K-LINE®.

Step 1 (Set 1)	Step 2	Step 3	Step 4	Step 5	Step 6 (Set 2)
Facing the far end of the field, position your vehicle along side and 2 - 2.5m away from the sprinkler/pod line.	Attach the hook and rope at the end of the sprinkler/pod line to the tow vehicle.	Drive along (parallel to) your sprinkler/pod line, staying within 2 - 2.5m of the line.	As you approach the midpoint of your field (running over the feed line), line up with your marker at the end of the field.	Continue to the end of the field and stop when the first pod is approximately 8m from the end of the field.	Unhook the sprinkler/pod line from your tow vehicle.

Shifting from Set 2 to Set 3

The following steps show how to move the K-LINE® 15m over to the right for the next set.

Step 1 (Set 2)	Step 2	Step 3	Step 4	Step 5	Step 6 (Set 3)
Position your vehicle as described above and hook the sprinkler/pod line to the tow vehicle.	Pull straight forward until you reach the third pod.	Veer right about 15m and straighten to align the vehicle with the end of the field.	Before reaching the center line, veer back slightly to the left and line up with the marker at the end of the field.	Pass over the feed line and continue to the end of the field.	Unhook the vehicle from the sprinkler/pod line.

Follow the steps above to shift the line to irrigate all the sections of the field.

Example of a Complete Shifting Schedule

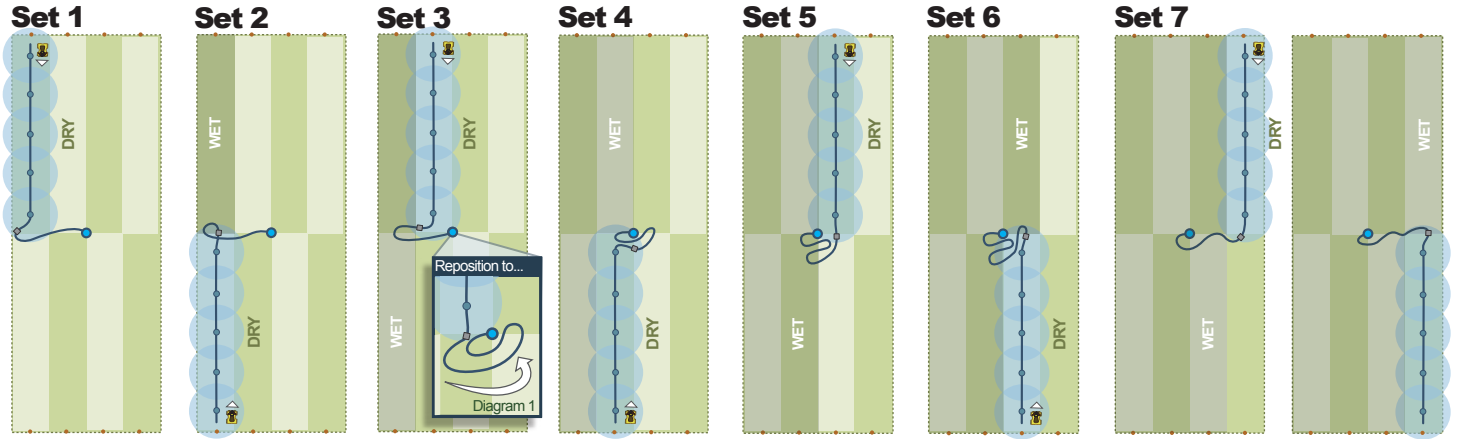

This is an example of the Sets and order of shifts to completely irrigate a field. For other field shapes and sizes please consult your K-LINE® dealer.

Repositioning the Feed Line

You will need to reposition the Feed Line at least once (sometimes more often) as you shift from Set to Set. In this Shifting Schedule, after the 2nd shift, where the K-LINE® is positioned to irrigate Set 3, the operator must manually take hold of the Feed Line at the point of the loop furthest from the riser. Then, as shown in **Diagram 1**, the operator must pull the Feed Line loop to a point about 3-5m to the right of the riser at mid-field.

The operator may also need to reposition the Feed Line if they see that the first sprinkler/pod (the sprinkler/pod closest to the riser or mid-field) is out of alignment with the other pods.

In this Shifting Schedule, this is most likely to occur after shifting the K-LINE® to the Set 7 position. In this situation, just pull the Feed Line (near the Pod line) to reposition the sprinkler/pod and Feed Line. Once the operator becomes familiar with the shifting procedure, the need to reposition (as in Set 7) will be less often.

K-LINE® Shifting Hints

To keep the final sprinkler (pod closest to the tow vehicle during shifting) from spraying the operator during shifting, use a clothes pin to prevent sprinkler movement, or a coffee can (or similar) over the sprinkler to redirect the spray. Remove after the K-LINE® has been shifted.

Always position the tow vehicle 2 - 2.5m from the K-LINE® to be shifted on the

dry (unirrigated) side of the K-LINE® - SEE page 8-9. This will prevent "double loops" in the Feed Line and reduce chances that the tubing will get kinked. Mark the ends of the field with large different colored markers or flags to help position your lines properly

The first sprinkler/pod may be out of line with the rest of the sprinklers/pods if you have not positioned the last pod (the sprinkler/pod furthest from mid-field) approximately 8m from the edge of the field; OR if the Feed Line needs to be repositioned (as after moving the K-LINE® to the Set 3 or Set 7 positions – see above, Repositioning the Feed Line, for more details).

Shifting K-LINE® in hot weather without water running through the tubing increases the chance of kinking. EITHER shift the line while irrigating, OR shift (without water running) in the early morning or early evening when the tubing is cool.

End of Season

Unhook the Feed Line and K-LINE® from the riser and shift it to the side of the field for storage or during harvest. Setting the K-LINE® on an incline, and the action of shifting the K-LINE® itself, will remove most of the water from the K-LINE®. K.PIPE® tubing will also stretch slightly to withstand some freezing. Open all riser and drain valves to drain the system and cover any open risers or tubing ends (cam dust caps and plugs are available) to prevent small animals from nesting inside.

If a significant amount of grass is allowed to grow up and entangle the K-LINE® (i.e., from autumn through to late spring when you begin irrigating again) then be sure to manually loosen the pods from the grip of the weeds before shifting the K-LINE®.

Resetting the System from Set 8 to Set 1

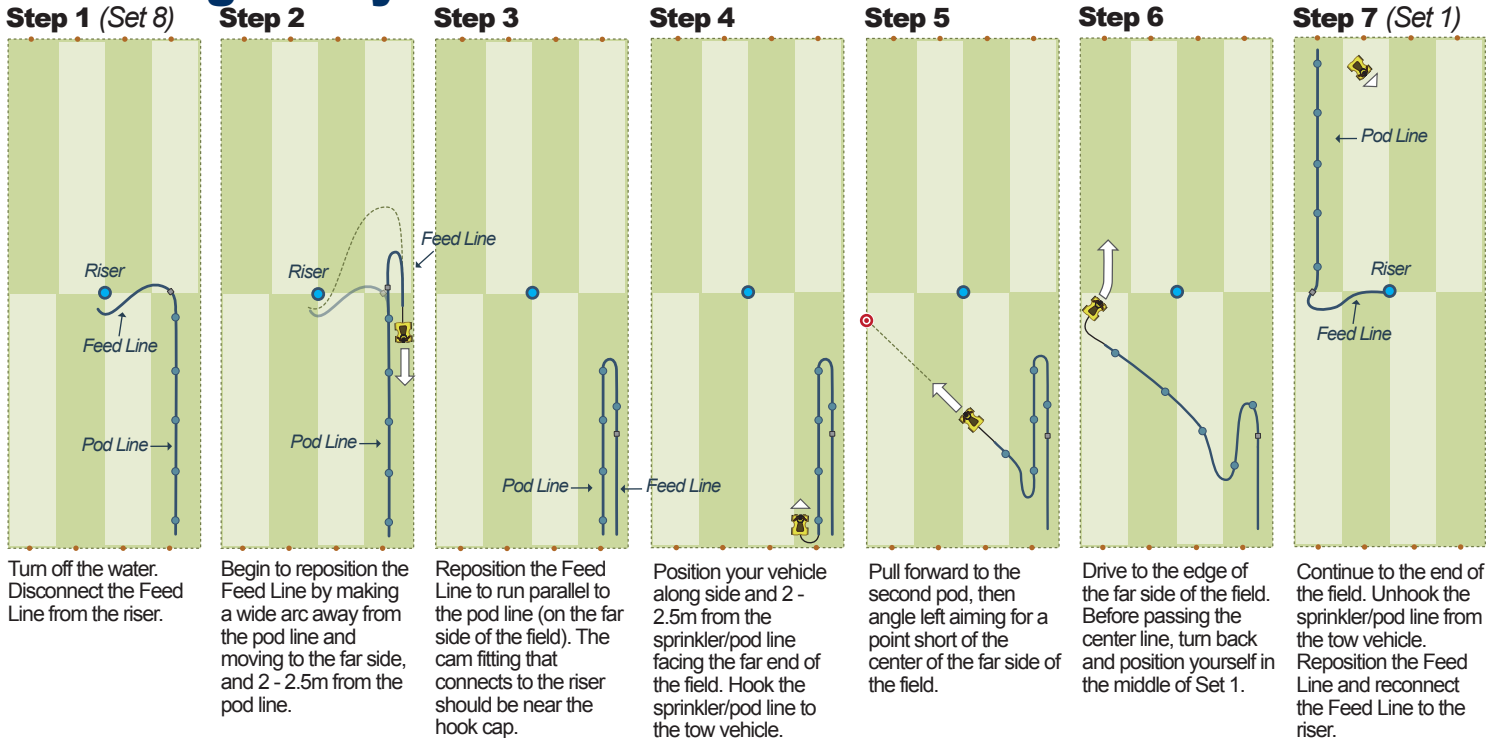

Turn off the water. Disconnect the Feed Line from the riser.

Begin to reposition the Feed Line by making a wide arc away from the pod line and moving to the far side, and 2 - 2.5m from the pod line.

Reposition the Feed Line to run parallel to the pod line (on the far side of the field). The cam fitting that connects to the riser should be near the hook cap.

Position your vehicle along side and 2 - 2.5m from the sprinkler/pod line facing the far end of the field. Hook the sprinkler/pod line to the tow vehicle.

Pull forward to the second pod, then angle left aiming for a point short of the center of the far side of the field.

Drive to the edge of the far side of the field. Before passing the center line, turn back and position yourself in the middle of Set 1.





Continue to the end of the field. Unhook the sprinkler/pod line from the tow vehicle. Reposition the Feed Line and reconnect the Feed Line to the riser.

K-LINE® Trouble Shooting Guide

Symptom	Possible Cause / Solution
Partial or poor distribution from sprinkler	<ul style="list-style-type: none"> plugged nozzle - remove nozzle, check for obstruction. obstruction in tubing - remove hook cap and flush line improper pump pressure - check pump damaged tubing leaking water - make square cuts to remove the damage, install Straight Coupling. saddle improperly mounted on tubing - remove and mount according to pages 5 and 6, STEP 8
Pods rolling over during shifting	<ul style="list-style-type: none"> towing vehicle is too far from K-LINE® - keep 1 - 1.5m from the pod line while shifting
Connectors coming loose	<ul style="list-style-type: none"> improper tightening of the K-LINE® connectors - cut off and discard 80mm of old scarred tubing when repairing (make sure that you have a square cut), then use pipe wrenches to more firmly tighten the connectors - see page 7, STEP 10A. If this fails, replace fitting with new fitting with sharp edges.
Water Stream hits the inside of the pod	<ul style="list-style-type: none"> tapping saddle is improperly tightened down - reposition tapping saddle and tighten down evenly, see pages 5 and 6, STEP 8
Feed Line loop gets too tight	<ul style="list-style-type: none"> Feed Line needs to be repositioned - see page 8, "Repositioning the Feed Line" Feed Line is too short - add more tubing or narrow the width of the irrigated area
K.PIPE® tubing gets kinked	<ul style="list-style-type: none"> failure to reposition Feed Line – see page 9, "Repositioning the Feed Line" - shifting the K-LINE® without water running when temperatures are hot - -straighten the kinked K.PIPE® tubing and use a rubber mallet to lightly pound the tubing back into shape

Performance Chart

1 Hectare K-LINE® Irrigation Kit # Impact sprinkler options with 15m between sprinklers and a 15m shift width

Nozzle Color & Size	Operating Pressure	Output per Sprinkler (litres per hour)	Total Water Required for 5 Sprinklers	Water Application Rate mm/Hour	Total Applied Water in 24 hr. Set	Average Application Rate Per Week <small>Based on 8 Shifts with Continuous Running</small>
 Orange - 2.8mm	250 kPa.	0.504 m³/hr	2.52 m³/hr	1.9 mm	54 mm	47 mm
	270 kPa.	0.524 m³/hr	2.62 m³/hr	2.0 mm	56 mm	48 mm
	300 kPa.	0.550 m³/hr	2.75 m³/hr	2.1 mm	59 mm	51 mm
 Red - 3.0mm	250 kPa.	0.576 m³/hr	2.88 m³/hr	2.2 mm	61 mm	53 mm
	270 kPa.	0.598 m³/hr	2.99 m³/hr	2.3 mm	64 mm	55 mm
	300 kPa.	0.630 m³/hr	3.15 m³/hr	2.4 mm	67 mm	58 mm
 Black - 4.0mm	250 kPa.	0.962 m³/hr	4.81 m³/hr	3.7 mm	103 mm	89 mm
	270 kPa.	0.998 m³/hr	4.99 m³/hr	3.8 mm	106 mm	93 mm
	300 kPa.	1.048 m³/hr	5.24 m³/hr	4.0 mm	112 mm	97 mm
The green and blue nozzles below are optional sprinkler nozzles available from a K-LINE® Dealer						
 Green - 3.2mm	250 kPa.	0.642 m³/hr	3.21 m³/hr	2.5 mm	69 mm	60 mm
	270 kPa.	0.668 m³/hr	3.34 m³/hr	2.6 mm	71 mm	62 mm
	300 kPa.	0.706 m³/hr	3.53 m³/hr	2.7 mm	75 mm	65 mm
 Blue - 3.5mm	250 kPa.	0.742 m³/hr	3.71 m³/hr	2.8 mm	79 mm	69 mm
	270 kPa.	0.770 m³/hr	3.85 m³/hr	3.0 mm	82 mm	71 mm
	300 kPa.	0.812 m³/hr	4.06 m³/hr	3.1 mm	87 mm	75 mm

Sample Design 1: One K-LINE® 5 Pod / 1 Hectare Kit

2 Shifts a day, uses 4 sprinkler pods

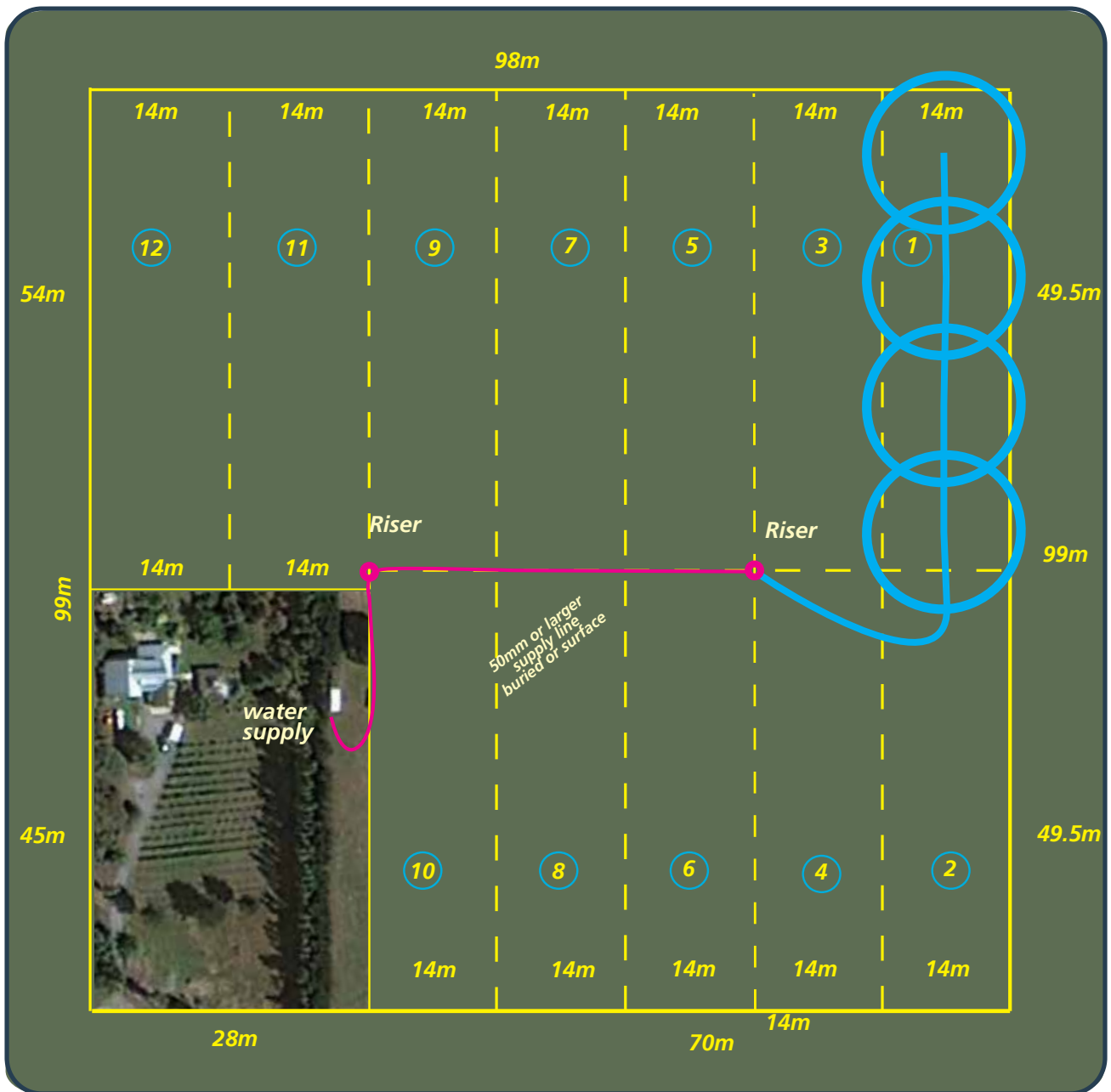

Design Specifications

Size of total area to be irrigated	0.85 Hectares
Number of sets or watering days required	12 Sets in 6 days
Distance between sprinkler pods	12.4 m.
Set widths	14 m.
Sprinkler nozzle color and size	Orange 2.8mm
Operating pressure available	330 kPa
Sprinkler application rate in mm per hour	3.2 mm/hr
Length of watering time per set	10 hours
Total amount of irrigation water applied during each set period	31.4 millimetres
System capability in mm per week applied	44
Number of sprinkler pods per K-LINE®	4
Output per sprinkler	550 litres/hr
Total cubic metres per hour (1000's litres) needed for this area	2.2 m³/hr

Notes

This layout uses only 4 pods of the kit, but there are two 10 hour shifts per day. By using the smaller orange 2.8mm sprinkler nozzle, this entire area can be covered in 6 days and still apply over 30mm of water per set.

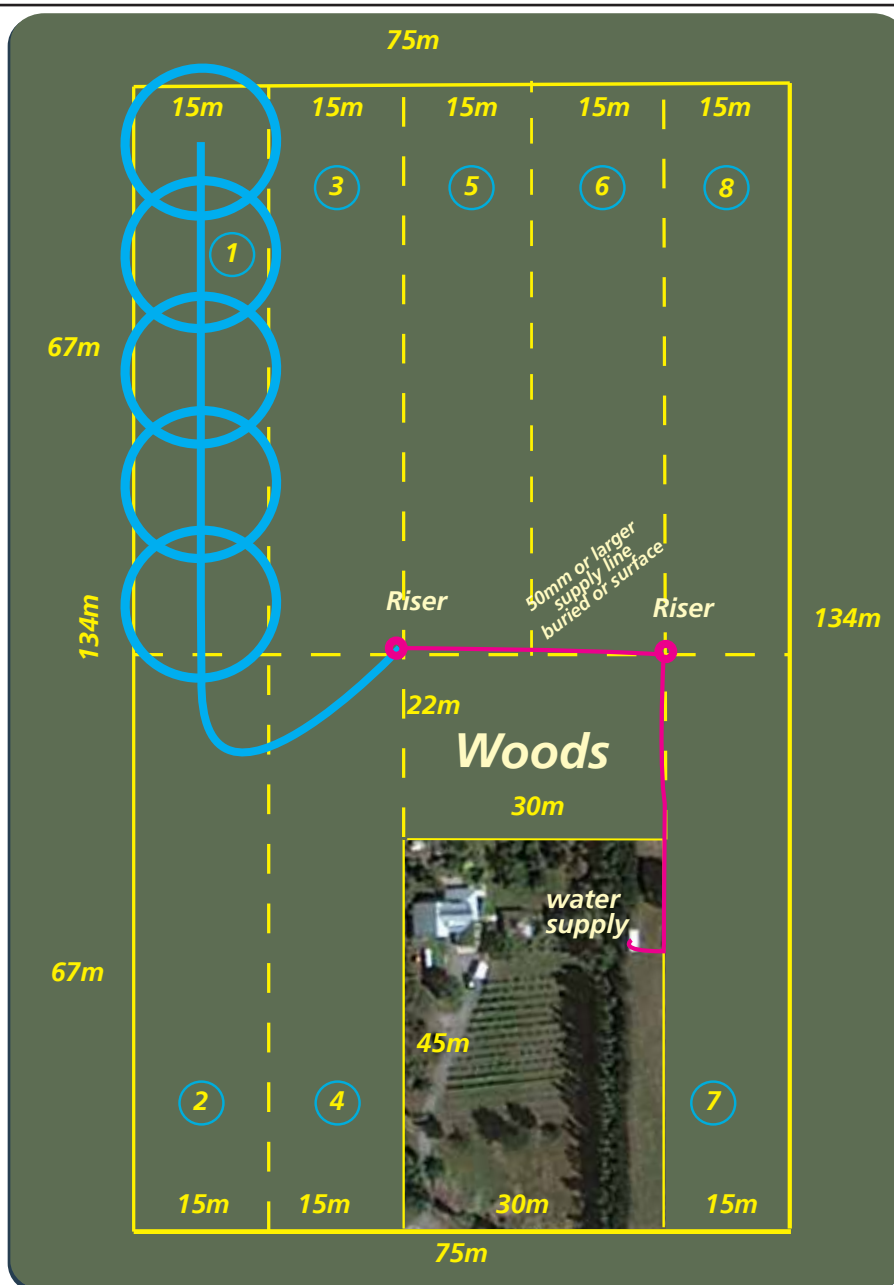

Design Specifications

Size of total area to be irrigated	0.8 Hectares
Number of sets or watering days required	8 days
Distance between sprinkler pods	13.4 m.
Set widths	15 m.
Sprinkler nozzle color and size	Orange 2.8mm
Operating pressure available	320 kPa
Sprinkler application rate in mm per hour	2.8 mm/hr
Length of watering time per set	12 hours
Total amount of irrigation water applied during each set period	32.9 mm
System capability in mm per week applied	57.6 mm
Number of sprinkler pods per K-LINE®	5
Output per sprinkler	560 litres/hour
Total cubic metres per hour (1000's litres) needed for this area	2.8 m³/hr

Notes

To move the K-LINE® from Set 5 to Set 6: Shut off the water, then disconnect the Feed Line from the Pod Line at the Cam Fitting. Next, shift the K-LINE® from Set 5 first into the Set 7 area and then immediately return to Set 6 with the Pod Line. Move the Feed Line to Riser 2. Reconnect to the Pod Line and restart the water.

To move the K-Line from Shift 1 to Shift 8: Use a similar procedure as described above by temporarily using the Set 2 area to line up the K-LINE® Pod Line.

In this layout, either the orange or red nozzle could be used to match the available water.

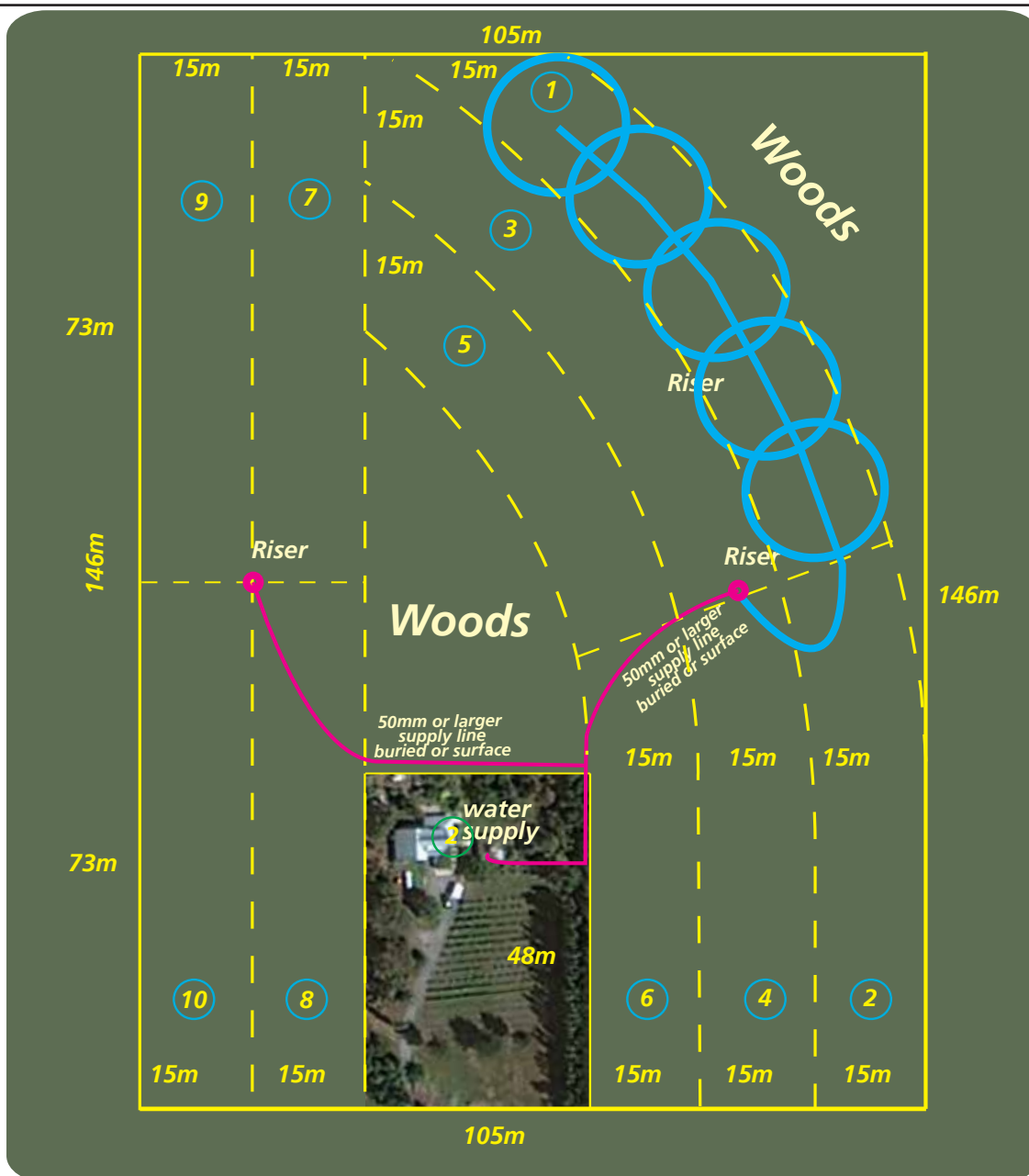

Design Specifications

Size of total area to be irrigated	1.1 Hectares
Number of sets or watering days required	10 days
Distance between sprinkler pods	14.6 m.
Set widths	15 m.
Sprinkler nozzle color and size	Orange 2.8mm
Operating pressure available	320 kPa
Sprinkler application rate in millimetres per hour	2.6 mm/hr
Length of watering time per set	12 hours
Total amount of irrigation water applied during each set period	30 mm
System capability in millimetres per week applied	42mm
Number of sprinkler pods per K-LINE®	5
Output per sprinkler	560 litres/hour
Total cubic metres per hour (1000's litres) needed for this area	2.8m³/hr

Notes

K-LINE® works easily around curves or other obstacles. On soil with good water holding capacity, the shift rotations can be increased by using additional riser locations. In the plan, the area irrigated would be completed in 10 day rotations.

Sample Design 4: Two K-LINE® 5 Pod / 1 Hectare (Ex) Kits Combined Shifting once per day

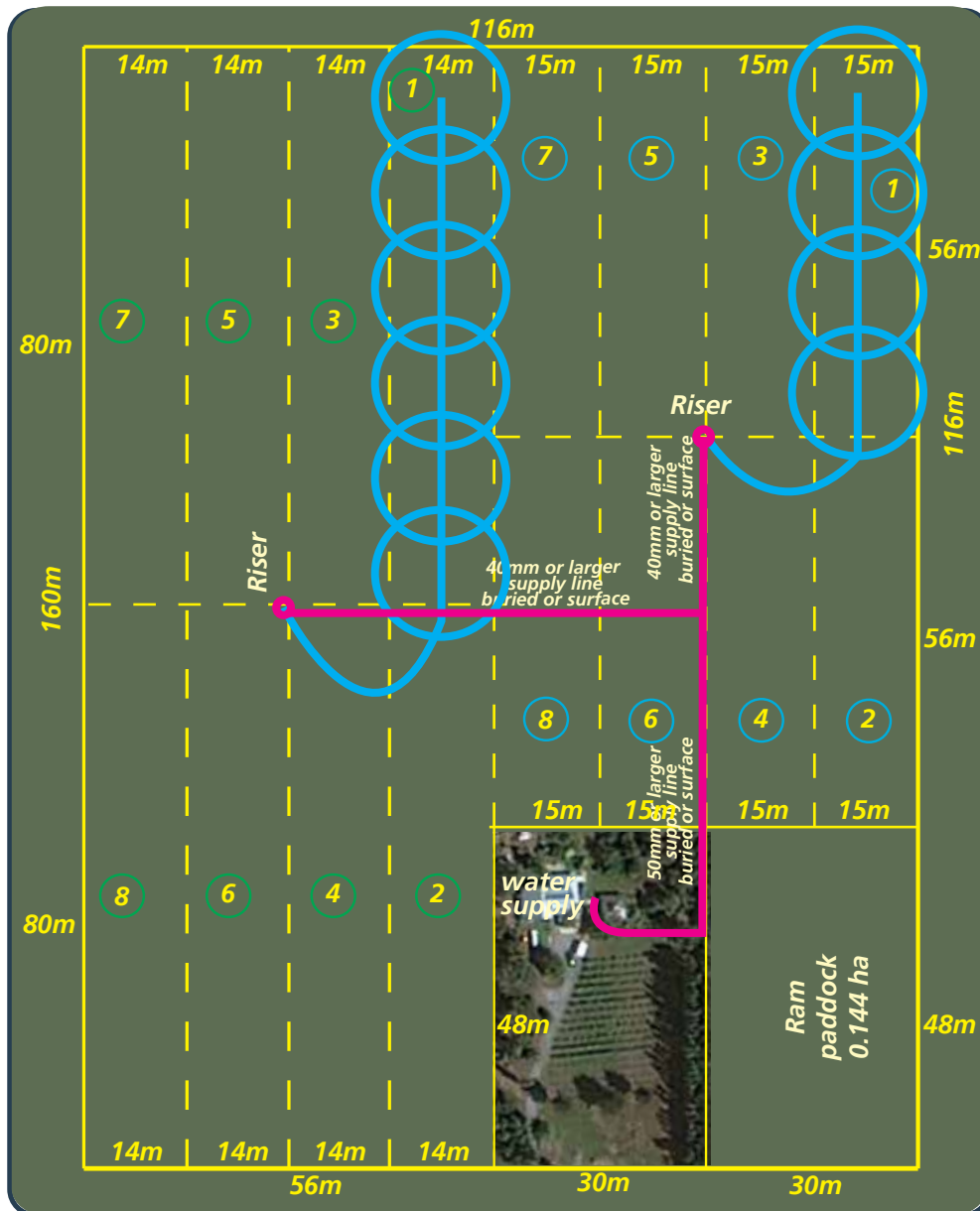

Design Specifications

	1-8	1-8	Totals
Size of total area to be irrigated	0.69 Ha	0.94 Ha	1.63 Ha's
Number of sets or watering days required	8 days	8 days	8 days
Distance between sprinkler pods	14 m.	13.33m	
Set widths	15 m.	14 m.	
Sprinkler nozzle color and size	Red 3.0mm	Orange 2.8mm	
Operating pressure available	330 kPa	330 kPa	330kPa
Sprinkler application rate in mm per hour	3 mm/hr	3 mm/hr	3mm/hr
Length of watering time per set	12 hours	12 hours	12 hours
Total amount of irrigation water applied during each set period	36mm	36mm	36mm
System capability in millimetres per week applied			63mm
Number of sprinkler pods per K-LINE®	4	6	10
Output per sprinkler	620 litres/hour	560 litres/hour	
Total cubic metres per hour (1000's litres) needed for this area	2.2m³/hr	3.8m³/hr	6.0m³/hr

Notes

Both K-LINE® sprinkler pod lines are operating at the same time.

By dividing the total parts from 2 K-Line 5 Pod Kits into a 6 sprinkler pod line and a 4 sprinkler pod line and then operating both K-LINES at the same time, a little over 1.5 hectares can be irrigated, applying about 36mm of water per set. This is designed for an 8 day rotation.

Sample Design 5: Two K-LINE® 5 Pod / 1 Hectare (Ex) Kits Combined Shifting once per day

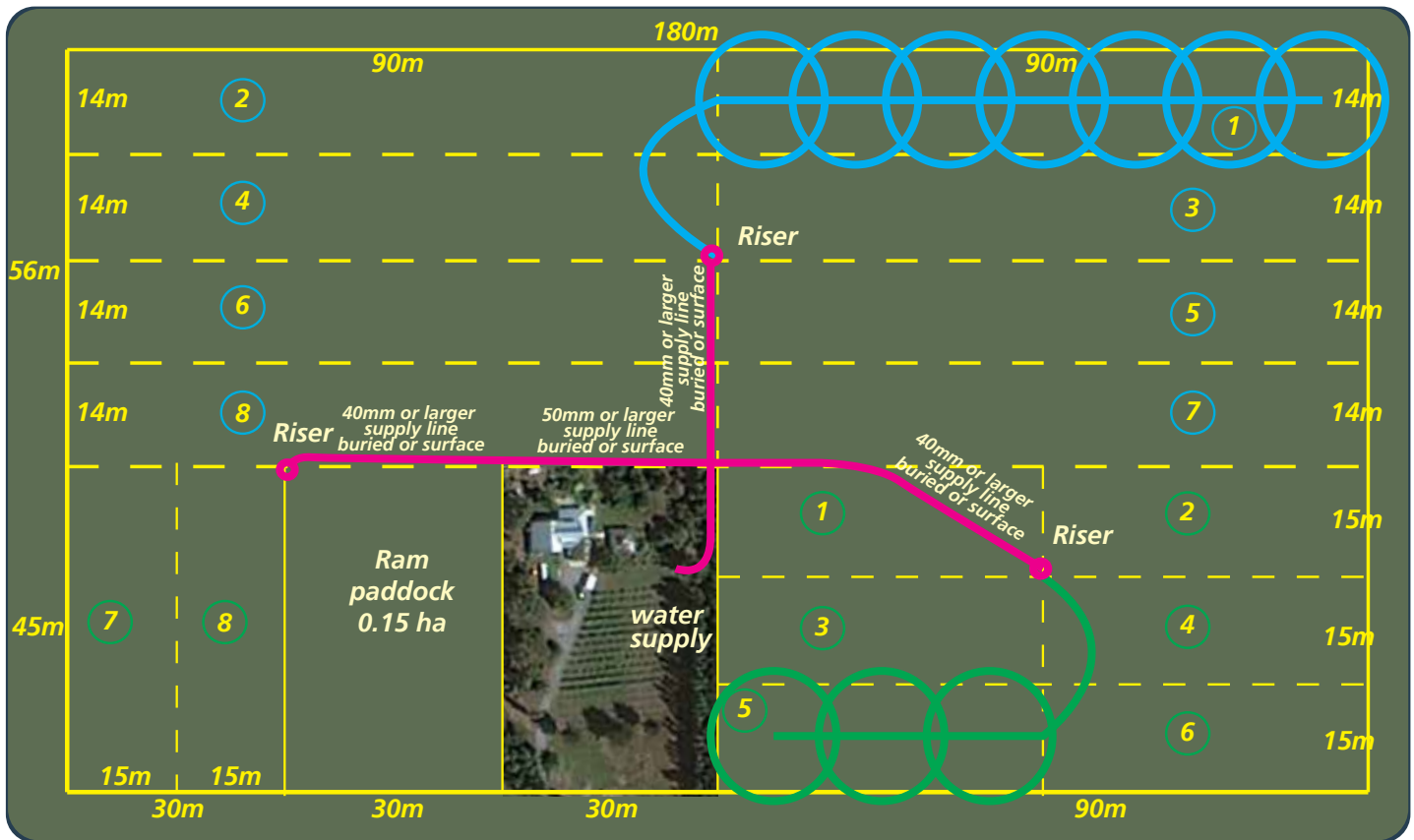

Design Specifications

	1-8	1-8	Totals
Size of total area to be irrigated	1.1 Ha	0.56 Ha	1.66 Ha's
Number of sets or watering days required	8 days	8 days	8 days
Distance between sprinkler pods	12.86 m.	15 m.	
Set widths	14 m.	15 m.	
Sprinkler nozzle color and size	Orange 2.8mm	Red 3.0mm	Red/Orange
Operating pressure available	320 kPa	320kPa	320 kPa
Sprinkler application rate in mm per hour	2.9 mm/hr	3 mm/hr	3 mm/hr
Length of watering time per set	12 hours	12 hours	12 hours
Total amount of irrigation water applied during each set period	34 mm	35mm	35mm
System capability in millimetres per week applied			60
Number of sprinkler pods per K-LINE®	7	3	10
Output per sprinkler	533 l/hour	628 l/hour	
Total cubic metres per hour (1000's litres) needed for this area	4.4 m³/hr.	1.6 m³/hr	6.0 m³/hr

Notes

This layout can be best irrigated with 2 separate K-LINE® sprinkler pod lines. One line has 7 pods and the other has 3 pods. Because the shift width and pod spacing is different for each K-LINE®, using a red nozzle in one and an orange nozzle in the other will equalize the water application rate.

Sample Design 6: K-LINE® Irrigation for your Rugby Field

This design can be used for football or soccer fields and consists of a 5 pod system with 8 sets or shifts.

The pods are spaced at 13m intervals, but spacing can be increased up to approximately 15m to accommodate your field. The Set or Shift widths are 16m wide but should not be increased any further, but could be moved closer to allow another full set to be added.

When water is applied at 320 kPa with a impact sprinkler with a black 4.0mm nozzle, the application rate is

approximately 4.8mm per hour. In this design, your total water requirement is 4.98m³/hr per hour.

Another shifting alternative is that the operator can either move the line every hour through the course of an 8 hour day, or every 2 hours over the course of 2 days.

Application amounts can be altered using different nozzle sizes and/or by adjusting watering time.

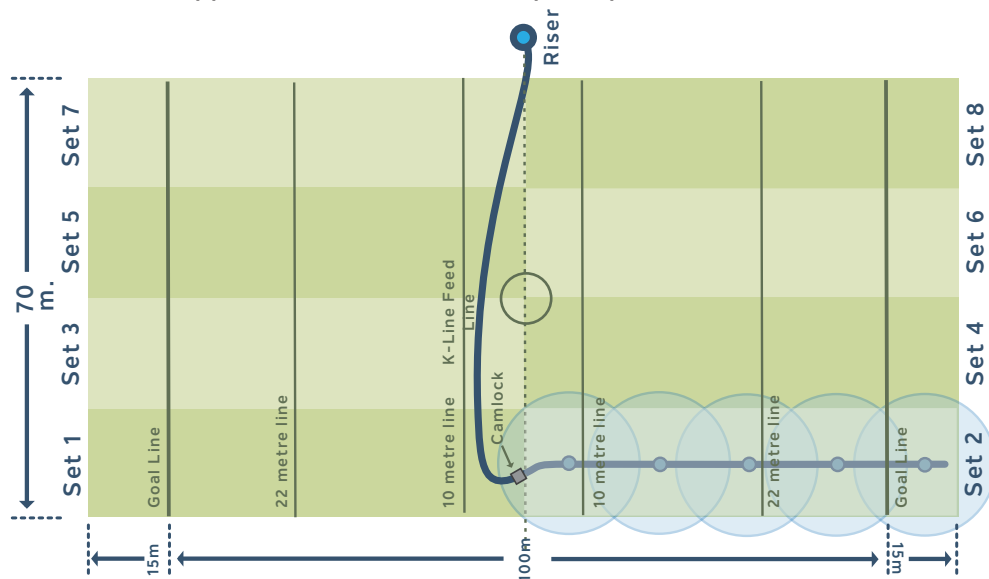

How to select an additional pack for your K-LINE® system

Number of Pods in your K-LINE® System @ 15m x 15m spacings								
Nozzle Colour mm/hr @ 3Bar	3 (90m)	4 (120m)	5 (150m)	6 (180m)	7 (210m)	8 (240m)	9 (270m)	10 (300m)
Orange 2.5mm	3 32mm 32mm Feed Line	4 32mm 32mm Feed Line	5 32mm 32mm Feed Line	3 & 3 32mm 32mm Feed Line	3 & 4 32mm 32mm Feed Line	3 & 5 32mm 32mm Feed Line	4 & 5 32mm 32mm Feed Line	5 & 5 EXTN 32-40mm 40mm Feed Line
Red 2.9mm	3 32mm 32mm Feed Line	4 32mm 32mm Feed Line	5 32mm 32mm Feed Line	3 & 3 32mm 32mm Feed Line	3 & 4 32mm 32mm Feed Line	3 & 5 32mm 32mm Feed Line	4 & 5 EXTN 32-40mm 40mm Feed Line	5 & 5 EXTN 32-40mm 40mm Feed Line
Green 3.2mm	3 32mm 32mm Feed Line	4 32mm 32mm Feed Line	5 32mm 32mm Feed Line	3 & 3 32mm 32mm Feed Line	3 & 4 32mm 32mm Feed Line	3 & 5 EXTN 32mm 40mm Feed Line	4 & 5 EXTN 32-40mm 40mm Feed Line	5 EXTN & 5 EXTN 40mm 40mm Feed Line
Blue 3.7mm	3 32mm 32mm Feed Line	4 32mm 32mm Feed Line	5 32mm 32mm Feed Line	3 & 5 EXTN 2 spare pods 32mm 40mm Feed Line	3 & 5 EXTN 1 spare pod 32mm 40mm Feed Line	3 & 5 EXTN 32-40mm 40mm Feed Line	4 & 5 EXTN 32-40mm 40mm Feed Line	5 EXTN & 5 EXTN 40mm 40mm Feed Line
Black 4.8mm	3 32mm 32mm Feed Line	4 32mm 32mm Feed Line	5 32mm 40mm Feed Line	3 & 5 EXTN 2 spare pods 32mm 40mm Feed Line	3 & 5 EXTN 1 spare pod 32-40mm 40mm Feed Line	3 & 5 EXTN 32-40mm 40mm Feed Line		

* Green and Blue nozzles can be bought separately, not supplied as part of the Farm Pack kit

Key to reading the chart

4 - Numbers of pods required in the line. (120m) - Field length. K-LINE® will cover half the field length.

Selection of K-LINE® Packs

Minimum pipe selection in the K-LINES on flat ground. Larger font size means more of that size pipe in the line.

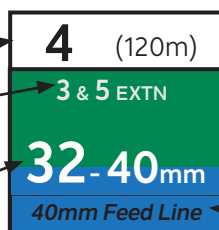

Approximate percentage of pipe selection required as a minimum. Green = 32mm, Blue = 40mm. nb: Actual selection may have more 40mm than shown.

Selection of K-LINE® Feed-Line from the Riser to the first pod minimum.