



Outdoor Network PTZ Dome Cameras

Quick Guide

V1.06

BOM:3101C0F5

Safety and Compliance Information

Installation and removal of the unit and its accessories must be carried out by qualified personnel. You must read all of the Safety Instructions supplied with your equipment before installation and operation.

Installation

- This device is a class A product and may cause radio interference. Take measures if necessary.
- Make sure the camera operates in an environment where the temperature and humidity meet requirements. Keep the camera from excessive pressure, vibration, moisture, dust, and intensive electromagnetic radiation.
- Use a power adapter or a PoE device that meets requirements. Otherwise, the device may be damaged.
- Make sure the length of the power cable between the power adapter and the camera is not too long, otherwise the voltage of the camera is lowered, causing the camera to work abnormally. If it is required to lengthen the power cable, lengthen the cable between the power adapter and the mains.
- Do not hold the tail cable by hand for weight bearing. Otherwise, the cable connector of the camera could be loosened.
- When connecting to an external interface, use an existing connection terminal, and ensure that the cable terminal (latch or clamp) is in good condition and properly fastened. Ensure that the cable is not tense during mounting, with a proper margin reserved to avoid poor port contact or loosening caused by shock or shake.
- The connectors of the tail cable must not be exposed. The bar cavity, waterproof box, corrugated pipe and PVC pipe must be fully sealed to protect the connectors from water. The waterproof components for the RJ45 plug must be used properly to protect the network cable from water.
- During the process of transportation, special attention is required for the protection of the transparent dome cover to prevent friction, scratch and

contamination, etc. In order to keep the cover clean, do not remove the protective film on the cover during mounting. After mounting is finished, remove the film before the device is powered on.

- Contact professionals for maintenance information. Do not attempt to dismantle the device by yourself. We shall not assume any responsibility for problems caused by unauthorized repair or maintenance.

Maintenance

- Caution: There will be risk of explosion if battery is replaced by an incorrect type. Dispose of used batteries according to the instructions.
- If there is dust on the front glass surface or the transparent dome cover, remove the dust gently using an oil-free brush or a rubber dust blowing ball.
- If there is grease or a dust stain on the front glass surface or the transparent dome cover, clean the cover gently from the center outward using lens cleaning cloth. If the problem persists, use lens cleaning cloth dipped with detergent and clean the dome cover or the glass surface gently until it is removed.
- Do not use organic solvents, such as benzene or ethanol when cleaning the transparent dome cover.
- Make sure the lens cleaning cloth is clean itself.

Laser Safety (if applicable)

- Installation and maintenance must be carried out by trained and qualified personnel.
- The camera must be mounted at least 6 meters above the ground.
- To avoid the risk of fire, the laser illuminator must be clear of obstacles within a minimum range of 30 centimeters.
- Make sure laser is disconnected from power before examination.
- Never stare into beam or view through any optical instruments. Avoid exposure to direct or scattered radiation. Be especially cautious during installation and maintenance.
- Never view lasers without protective eyewear. Some lasers emit infrared or ultraviolet, which are invisible to human eyes.
- Keep flammable or explosive objects away from laser beam. Some lasers may ignite combustible materials and thus cause fire.

- Never direct laser at a person. Do not direct laser at glass. The reflection may still cause harm to human eyes.



- Never look at the transmit laser while the power is on. Never look directly at the fiber ports and the fiber cable ends when they are powered on.
- Use of controls or adjustments to the performance or procedures other than those specified herein may result in hazardous laser emissions.

Regulatory Compliance

FCC statements

This device complies with Part 15 of the FCC Rules. Operation is subject to the following two conditions: (1) this device may not cause harmful interference, and (2) this device must accept any interference received, including interference that may cause undesired operation.

Caution: The user is cautioned that changes or modifications not expressly approved by the party responsible for compliance could void the user's authority to operate the equipment.

Note: This equipment has been tested and found to comply with the limits for a Class A digital device, pursuant to part 15 of the FCC Rules. These limits are designed to provide reasonable protection against harmful interference when the equipment is operated in a commercial environment. This

equipment generates, uses, and can radiate radio frequency energy and, if not installed and used in accordance with the instruction manual, may cause harmful interference to radio communications. Operation of this equipment in a residential area is likely to cause harmful interference in which case the user will be required to correct the interference at his own expense.

LVD/EMC Directive



This product complies with the European Low Voltage Directive 2014/35/EU and EMC Directive 2014/30/EU.

WEEE Directive–2012/19/EU



The product this manual refers to is covered by the Waste Electrical & Electronic Equipment (WEEE) Directive and must be disposed of in a responsible manner.

Battery Directive-2013/56/EC



Battery in the product complies with the European Battery Directive 2013/56/EC. For proper recycling, return the battery to your supplier or to a designated collection point.

Appearance

Dimensions

The figures in the manual are for your reference only. The actual appearance may vary with the product model.

Front View of an Infrared PTZ Dome	Front View of a Laser PTZ Dome
---------------------------------------	-----------------------------------

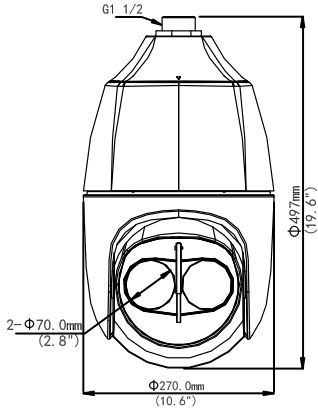
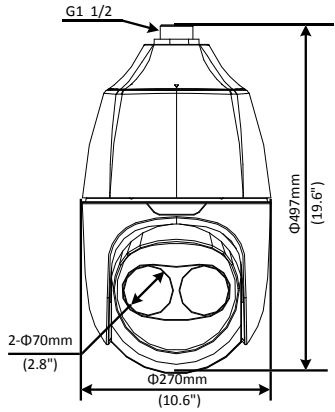
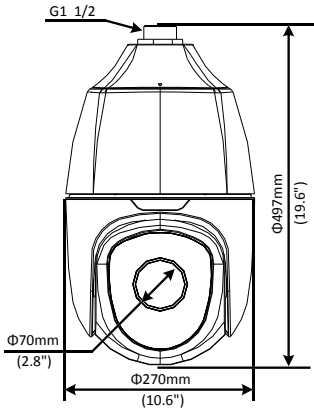

Cable Connection

All cables are tagged to indicate their functions separately. You can connect cables by referring to the following figure. The appearance and tail cable may vary with device model.

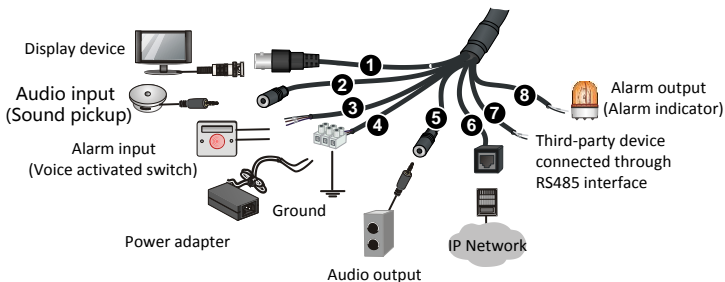

For specifications, see the latest product datasheets.

Mount Your Camera

The mounting steps for other dome camera models are similar. Here takes IR PTZ dome as an example. The figures in the manual are for your reference only. For the actual appearance, see the camera.

Check Before Mount

Figure 1 Camera components

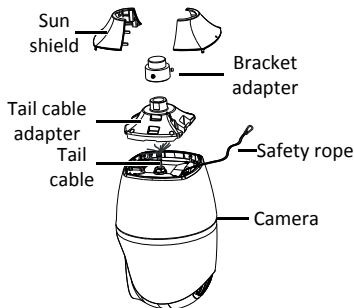

- Verify the bearing capacity of the mounting position.

Verify that the mounting position meets the bearing requirements. Otherwise, it is recommended to reinforce the mounted position for the camera weight. For more information, see the product datasheet.

- Verify the lightning protection and grounding requirements.

Select proper lightning protection devices for the power supply, audio and video interfaces, and RS485 interfaces.

Cable Requirements

- Network cable

10M/100M Ethernet CAT5 UTP cables are applicable to the ANSI/EIA/TIA-568A/B and ISO/D.

Eight wires in the network cable need to be inserted in parallel into the top of the cable connector. The cable connector needs to be crimped in position. When the cable connector is in position, ensure that the metal pieces of the cable connector are parallel to each other and the clamp of the cable connector is intact.

- Power cable



- Data listed in the table below is applicable to copper cables that use 24 VAC/24 VDC power supply. The item Core Diameter indicates the conductor diameter.
- Please calculate the camera's power consumption (power voltage \times electric current) based on the power voltage and electric current displayed on the nameplate of the actual device.
- For PoE devices, please use Category 5e or higher level network cables.

Table 1 Maximum Length and Power of the Power Cables

Diameter(mm) Distance(m) Power VA	0.80 (AWG20)	1.00 (AWG18)	1.25 (AWG16)	1.63 (AWG14)	2.00 (AWG12)
10	143	223	349	593	892
20	72	112	175	297	446
30	48	74	116	198	298
40	36	56	87	148	223
50	29	45	70	119	179
60	24	37	58	99	149
70	–	32	50	85	128
80	–	28	44	74	112
90	–	–	39	66	99
100	–	–	35	59	89
110	–	–	32	54	81
120	–	–	–	49	74

Table 2 Phoenix Terminal for the Power Cable

Power Supply	Cable Color
24 VAC 3A/24 VDC 2.5A	+/-: The anode and the cathode are not distinguished for the red and black cables.
	GND : yellow-green, used to ground the camera. Note: Ensure that the terminal is connected to a reliable grounding point.

Take out Camera

Please take out the dome camera from the packing box using a lifting handle.



Please remove the lifting handle before installing the sun shield.

Process Map

Make sure the camera is disconnected from the power during installation.



- Accessories such as the wall mount bracket may be necessary during mounting. For supported models, refer to the recommended list provided by your dealer.
- The wall bearing capacity and the bracket length must satisfy mounting requirements. Select a proper mount mode according to the actual situations.

Figure 2 Mounting Process

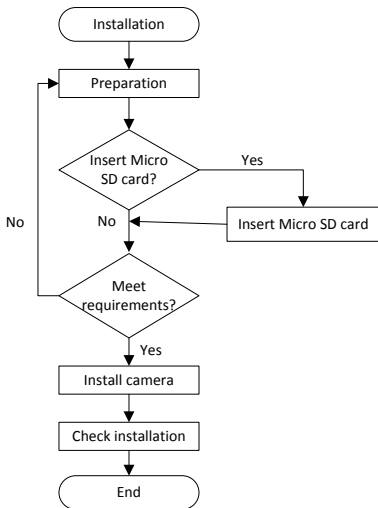

Insert Micro SD Card & Reset Camera to Default Settings

Please install the Micro SD card first, then format the Micro SD card in the software interface before use. Disconnect the camera from power before installation, otherwise the camera or the Micro SD card might be damaged.



- For details about recommended SD card specifications, contact your dealer.
- The following figures are only for your reference. For actual Micro SD card slot position, see the delivered camera.

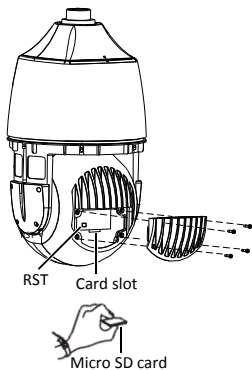

1. Insert Micro SD Card (Optional)

Remove the rear cover by loosening the screws. Then insert the SD card and replace the cover. Make sure the waterproof ring is installed into position in the cover.

2. Reset Camera to Default Settings

Remove the rear cover from the camera. Press and hold the RST button for about 15 seconds. The RST button only works within ten minutes after the camera is powered on. Then the camera is restored to the default settings after the restart.

Wall Mount



- When mounting the camera, please install the bracket adapter to the bracket first and then mount the camera to the bracket.
- Pay attention to the stainless screws that connect the tail cable unit and the camera. Verify that they are tightened so that the camera is entirely sealed. Ensure that the sun shield on the tail cable unit is mounted in position.
- Fasten the screws of various joints connecting to the dome camera, such as the bracket and the adapter ring, and ensure that no screws are missing.
- Take measures to waterproof and seal connections between dome and bracket, wall veneer slits and cable out holes on the wall.
- The following section describes concealed installation. To implement open installation, directly lead the cable out of the leading-out hole on the flank of the bracket.

1. Locate the positions of the holes, drill holes on the wall and then knock the expansion bolts, and verify that they are tightened up.

Mark the positions of the holes by referring to the mount points of the bracket. Lead the cables to be connected out of wall holes. Select a drill bit matching the outer diameter of the expansion bolt. For the hole depth, refer to the bolt length.

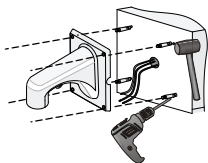

2. Screw in the bracket adapter (G1 ½ male thread) to the mount bracket. Then tighten the screws (M4) at the bracket.

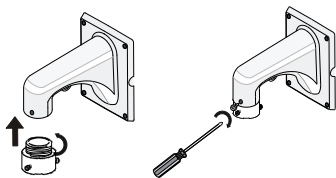

3. Align the top screws on the tail cable adapter to the inner track on the bracket adapter, push up and then turn the tail cable adapter till it is blocked by the bracket adapter screw.

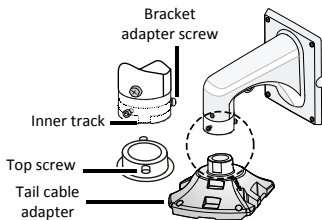

4. Fasten the bracket on the four expansion bolts by using flat washers, spring washers, and nuts.

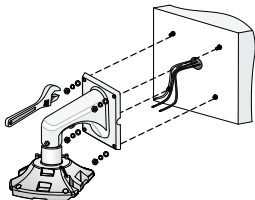

5. Hang the other end of the safety rope to the bracket and connect all the tail cables. Then hold the camera and secure the screws on the tail cable adapter.

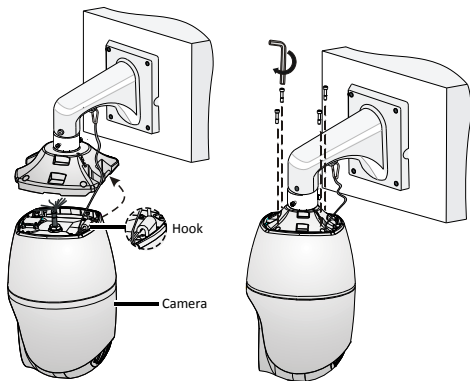

6. Mount the top sun shield.

Combine the left and right halves of the top sun shield by aligning them concurrently with the triangle icon of the dome. Then attach them downwards on the dome.

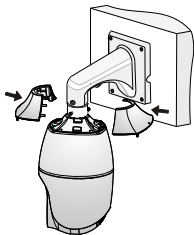

Waterproof Components for an RJ45 Plug

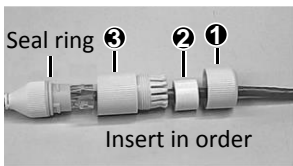

Attach the seal ring to the Ethernet interface. Mount the waterproof components in order. Then insert the cable into the Ethernet interface and screw the waterproof bolt in.



You can crimp the inner wires of the cable with the RJ45 plug first and then cover the waterproof components. You may also cover the waterproof components first.

Access Your Camera

Before you begin, check that:

- Your camera is operating properly and connected to the network.

- The PC you are using is installed with Internet Explorer 7.0 or later. IE 8.0 is recommended.

Follow these steps to access your camera through the Web interface:

1. Open your browser, input the IP address of your camera (default IP is **192.168.1.13**) in the address bar and then press **Enter** to open the login page.
2. Enter the username (default is **admin**) and password (default is **123456**) and then click **Login**.



- The default password is used for your first login. To ensure account security, please change the password after your first login. You are recommended to set a strong password (no less than eight characters).
- Install the ActiveX at your first login. When the installation of the ActiveX is completed, open your IE to log in.
- For your first login with Windows 7, if the system does not prompt you to install ActiveX, follow these steps to turn off UAC: click the Start button, and then click Control Panel. In the search box, type uac, and then click Change User Account Control Settings. Move the slider to the Never Notify position, and then click OK. After UAC is turned off, log in again.
- If the installation failed, open Internet Option in IE before login. Click the Security tab, click Trusted sites, and then click Sites to add the website. If you use Windows 7, you need to save the setup.exe to your PC first, and then right-click the file, select Run as administrator, and then install it according to instructions.