

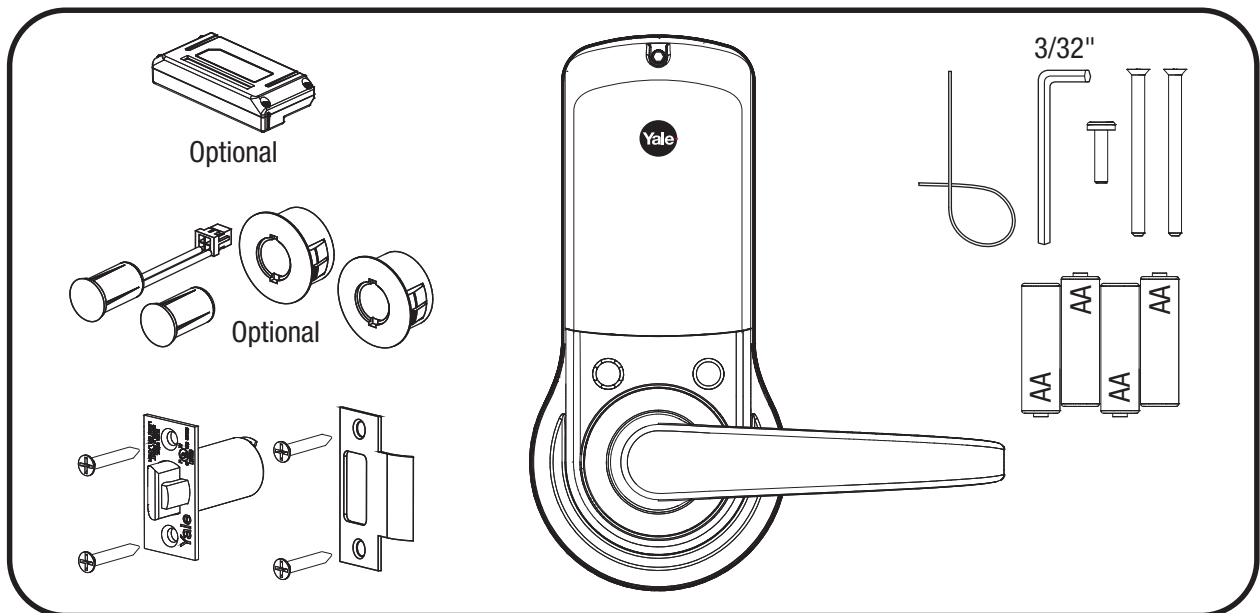

nexTouch™
Touchscreen and Push Button Access Cylindrical Lock
Installation and Programming Instructions

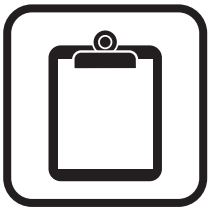

Retrofitting or modifying this product may impact fire rating, safety features and warranty.
Consult with code specifications to ensure compliance with all codes and ratings.



Determining Handing



The hand of a door is determined from the secure side of the door. The term "secure" means the side from which you initially unlock and enter.

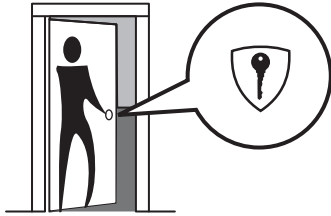

Left Hand "LH", Hinges Left.
Open Inward.

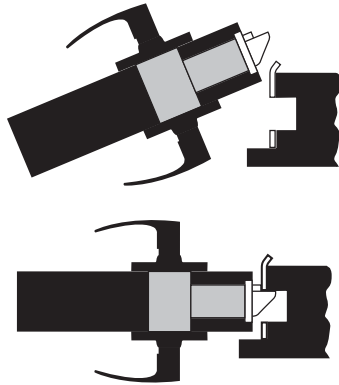

Left Hand Reverse "LHR", Hinges Left.
Open Outward.

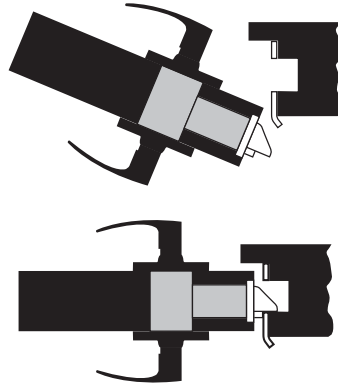

Right Hand "RH", Hinges Right.
Open Inward.

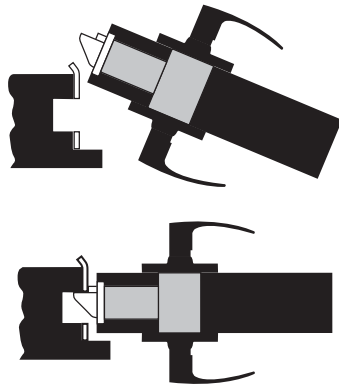

Right Hand Reverse "RHR", Hinges Right.
Open Outward.

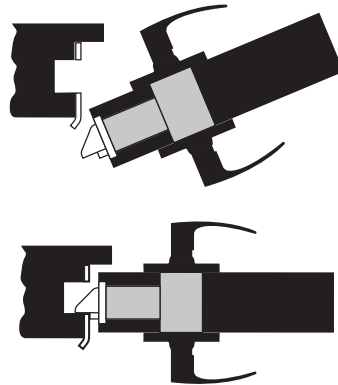

1

Preparing Door

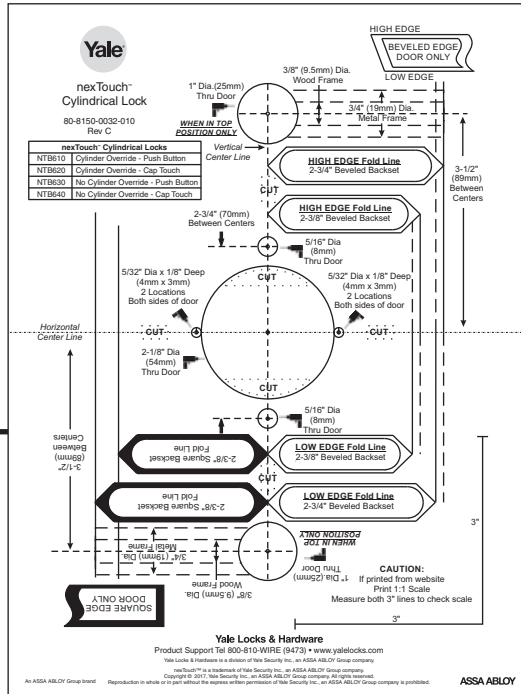

DPS Option
Wood Door:
3/8" Dia. x Thru to
Hole in Door Face

***Metal Door:**
3/4" Dia. Thru to
Hole in Door Face

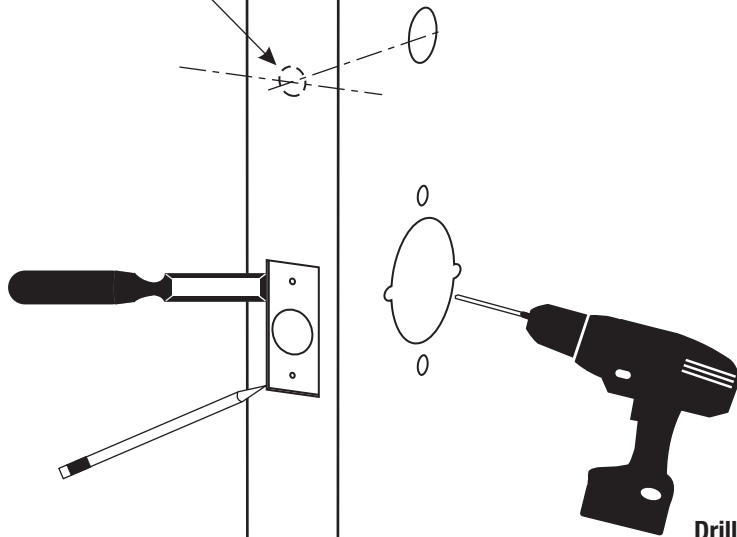

Drill holes 1/2 way thru door then complete from other side to prevent splitting.



***Metal Door Installations**
Supplied plastic collar **MUST** be installed for DPS to function properly.

2

Preparing Frame



7-16 / 8-32 x 1" UNCWS



x2

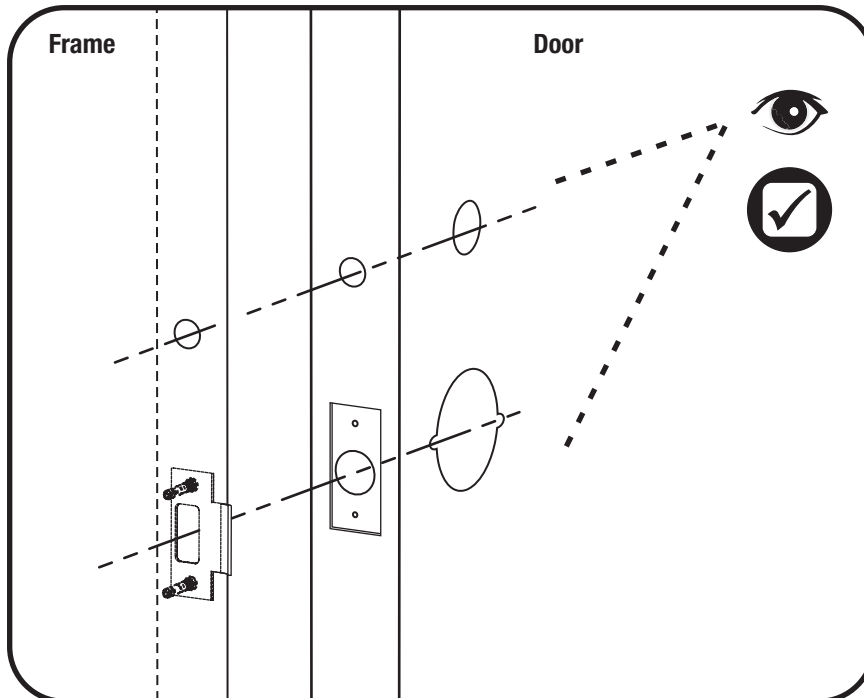
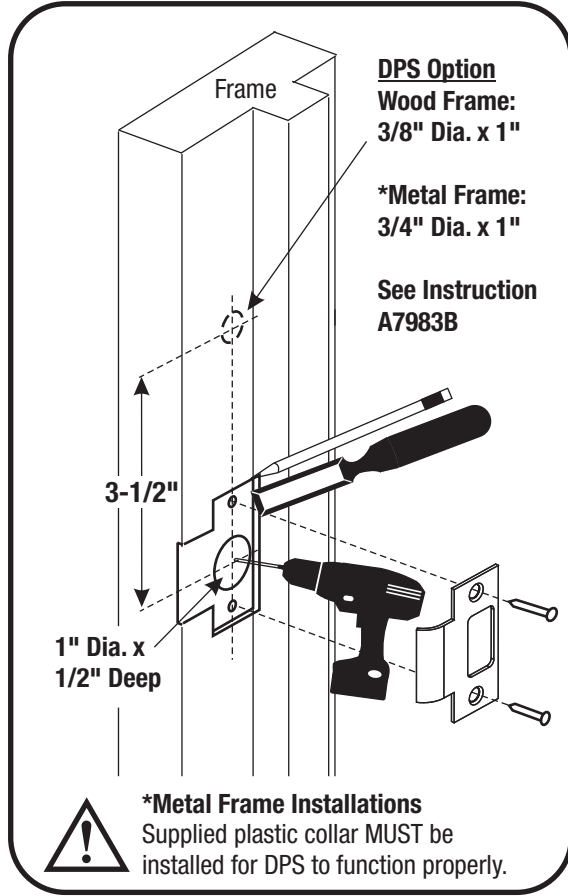
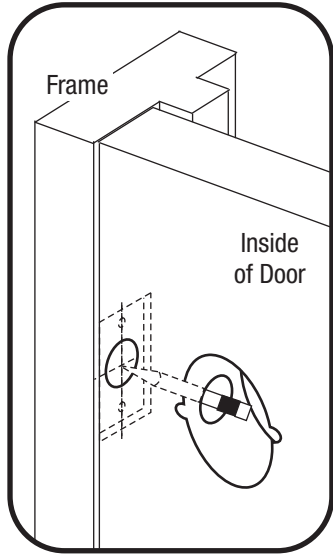

3

Preparing Inside Escutcheon

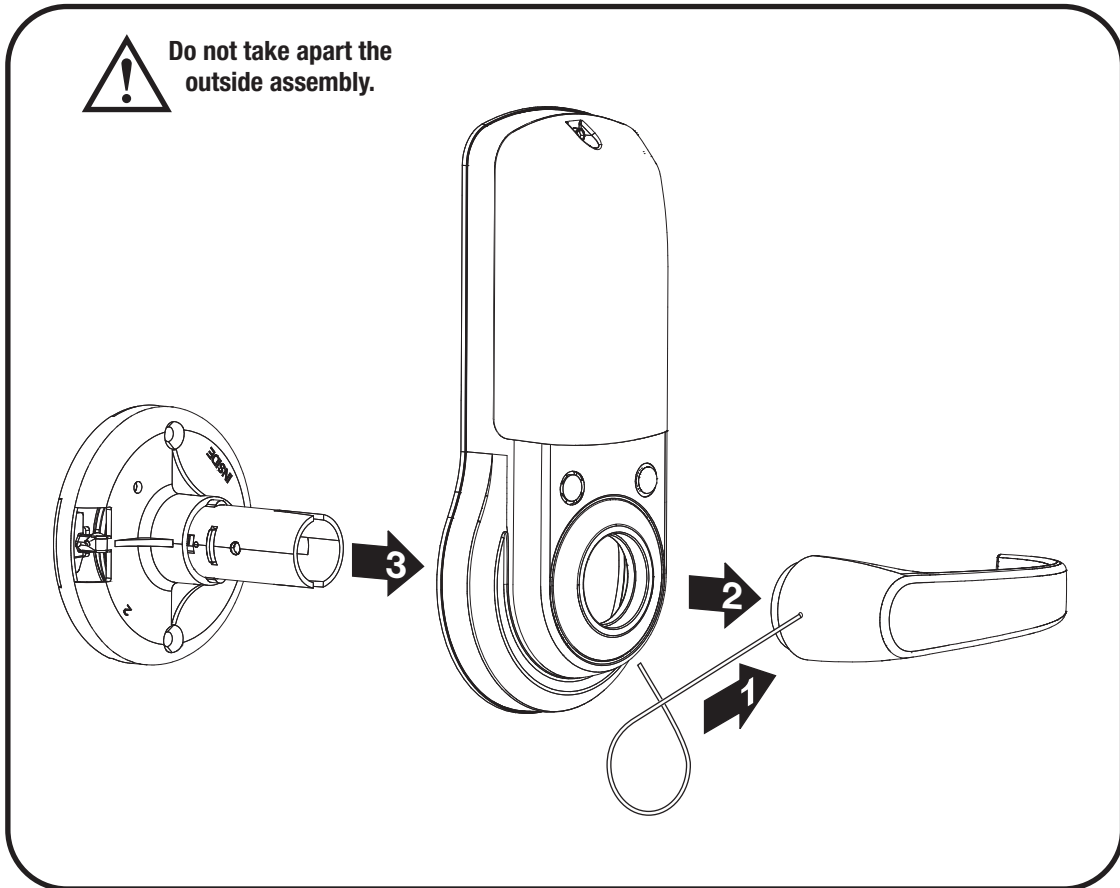

4

Installing Latchbolt

2-3/8" Latchbolt for thin doors sold separately.
See Installation Options.



7-16 / 8-32 x 1" UNCWS



x2

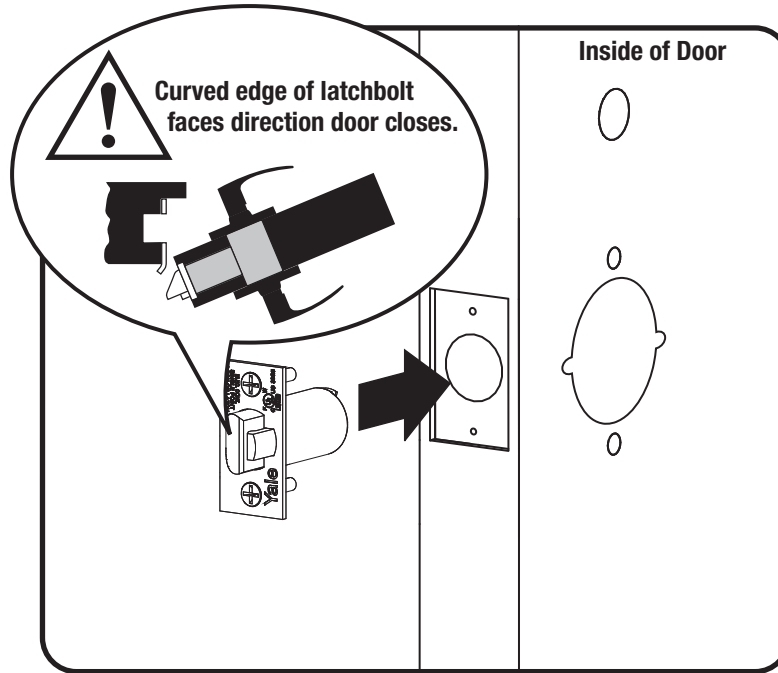

5

Removing Battery Cover

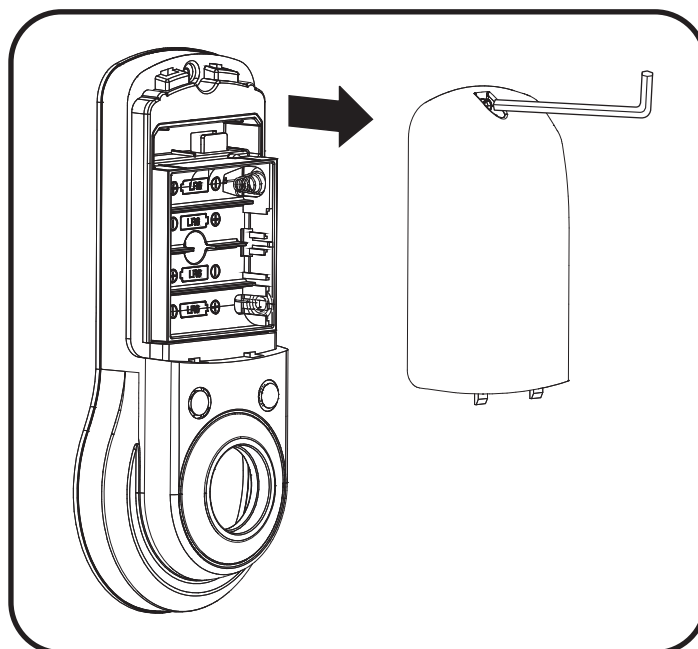

6

Installing Outside Assembly

Thin door gaskets sold separately.
See Installation Options.

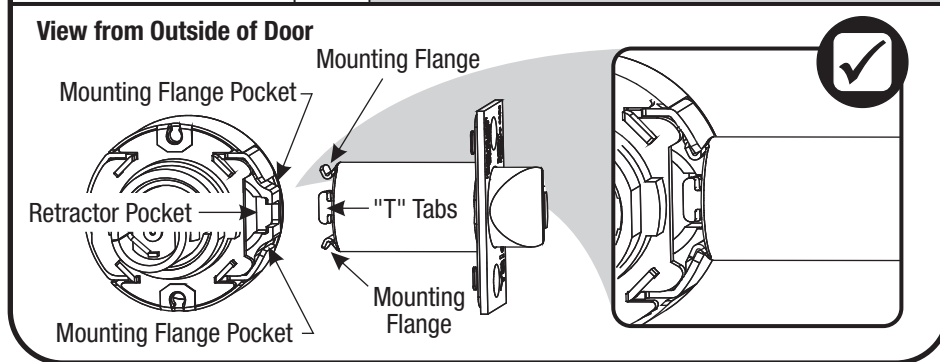
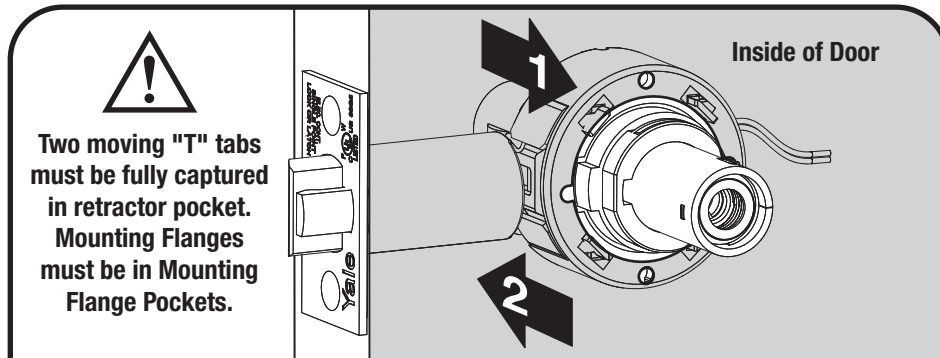
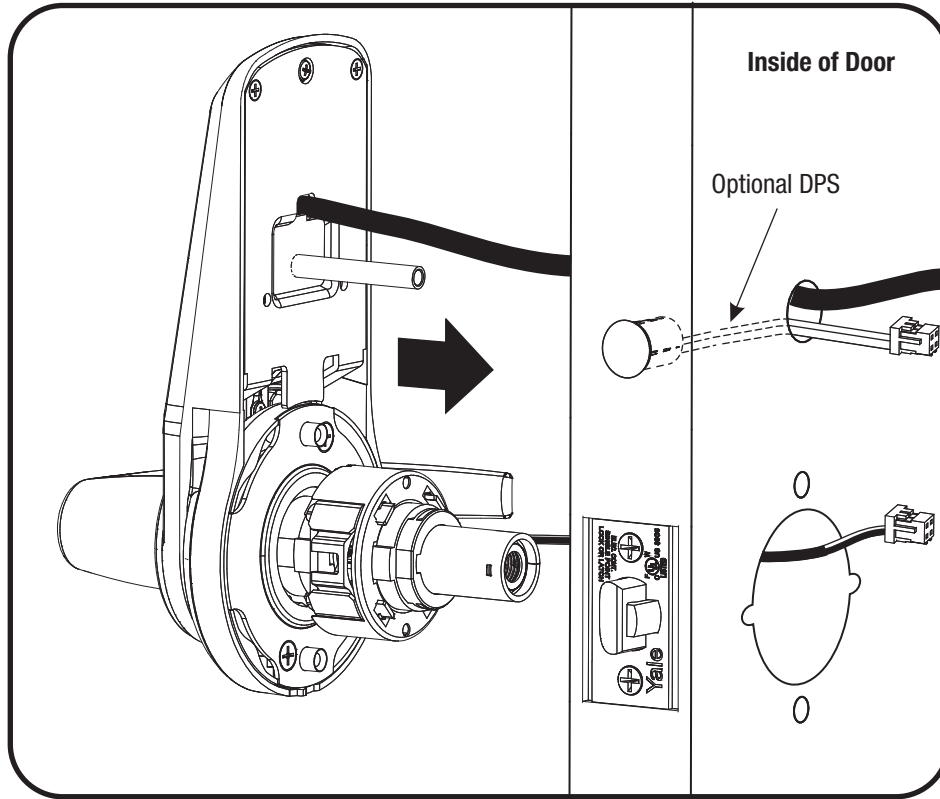

7

Installing Inside Support Assembly



10-32 x 2-1/2" PFHMS



x2

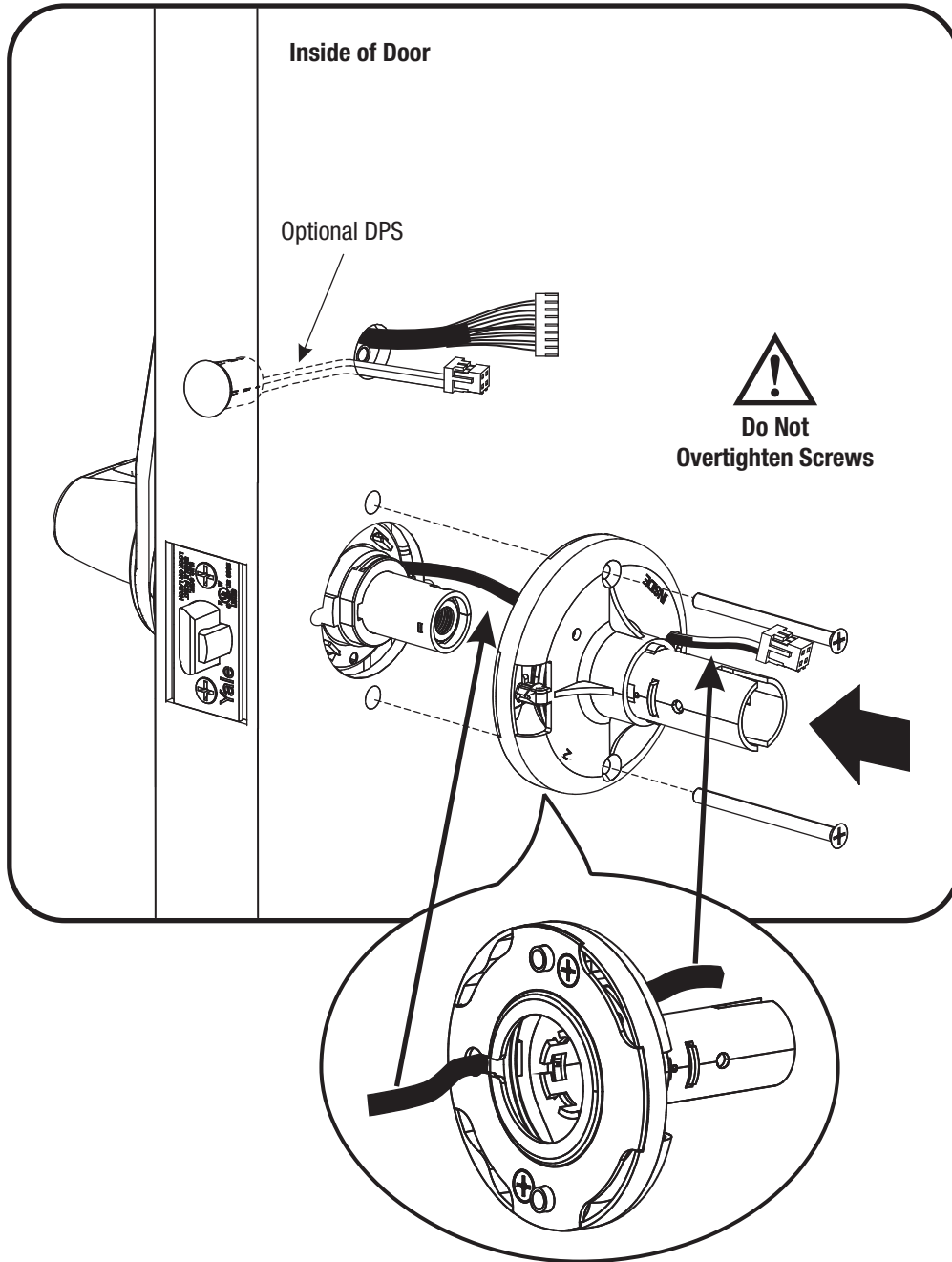

8

Attaching Cables

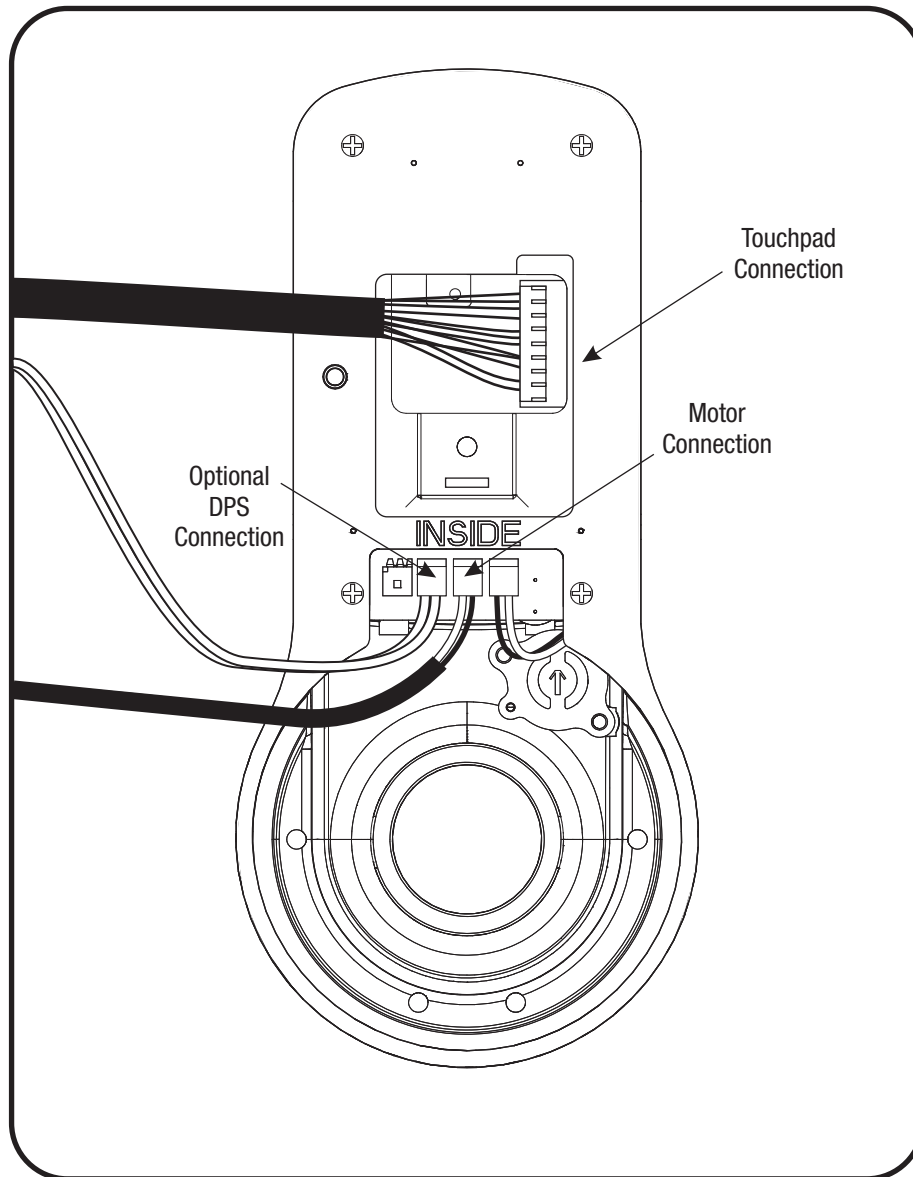

9

Installing Inside Escutcheon

Thin door gaskets sold separately.
See Installation Options.

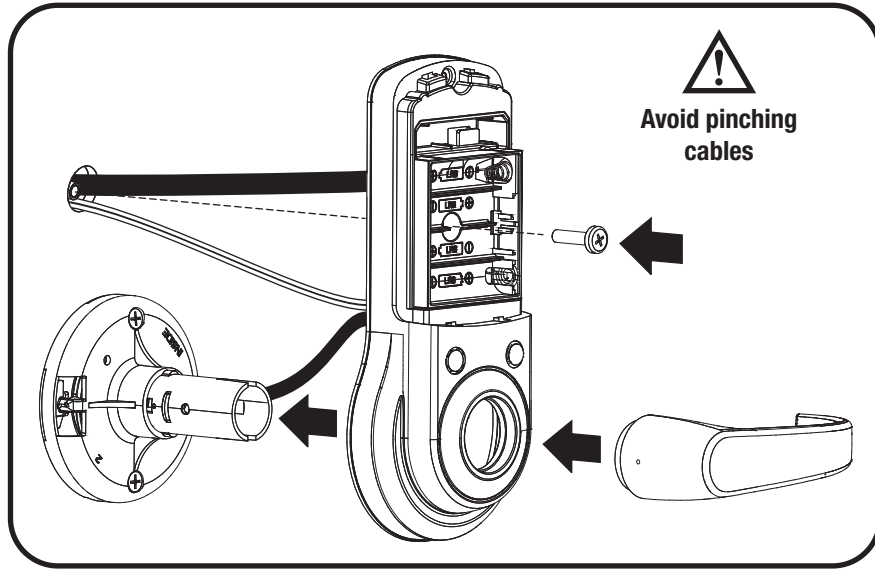

Testing Inside Lever Operation

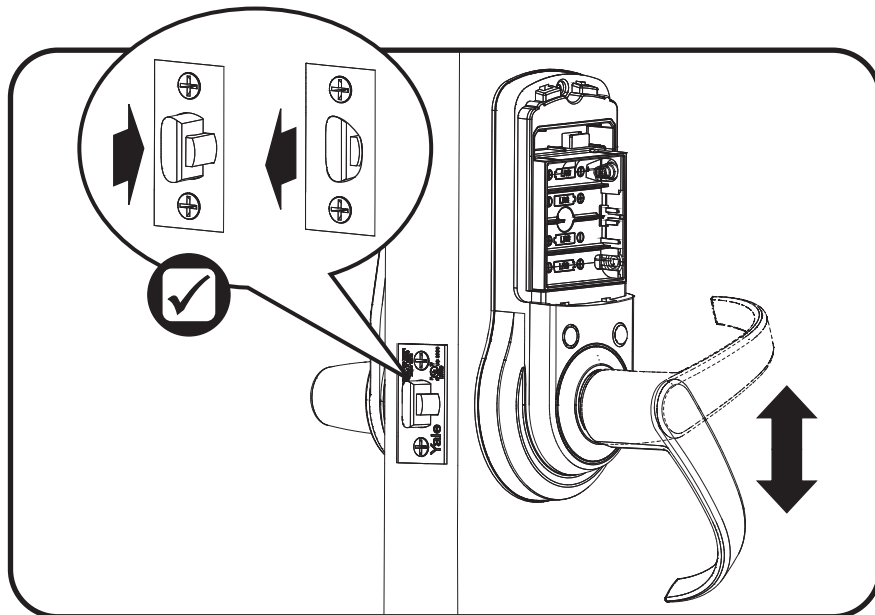

10

Installing Batteries & Cover

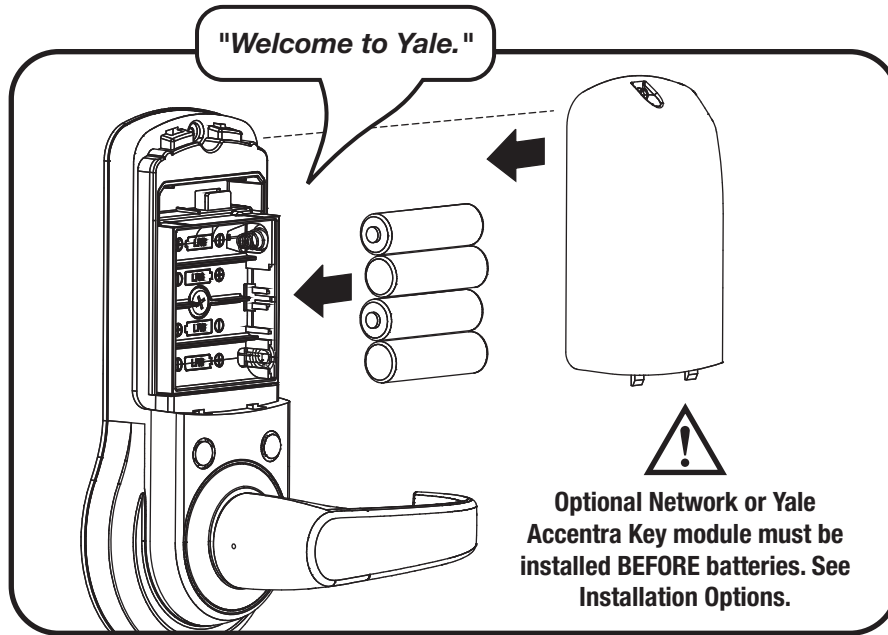

Congratulations, you've installed the Yale nexTouch™ Lock!
Continue on next page to customize your product.



Installation Options

Adjusting for 1-3/8" Door (if necessary)



Order 1-3/8" Thin Door Kit: 14-4761-0106

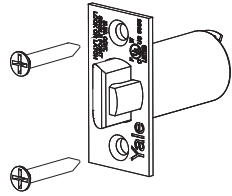

2-3/8" Latchbolt

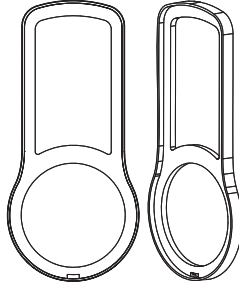

Outside Gasket

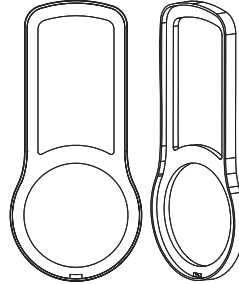

Inside Gasket

Privacy DPS Switch

Door Position Switch Option enables Privacy feature

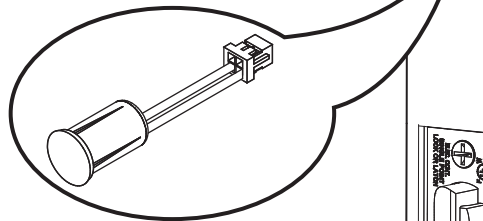

Metal Frame/Door Installations

Supplied plastic collars MUST be installed for DPS to function properly.

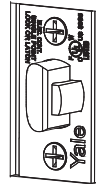

Inside of Door

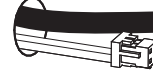

Network or Yale Accentra Key Module

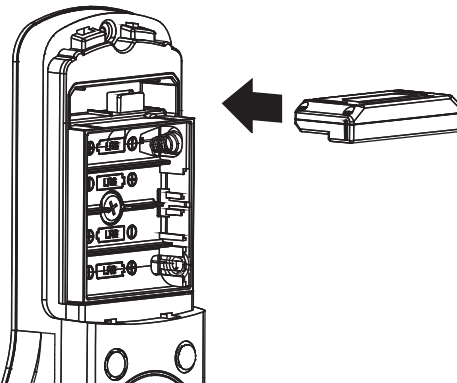

Programming Instructions

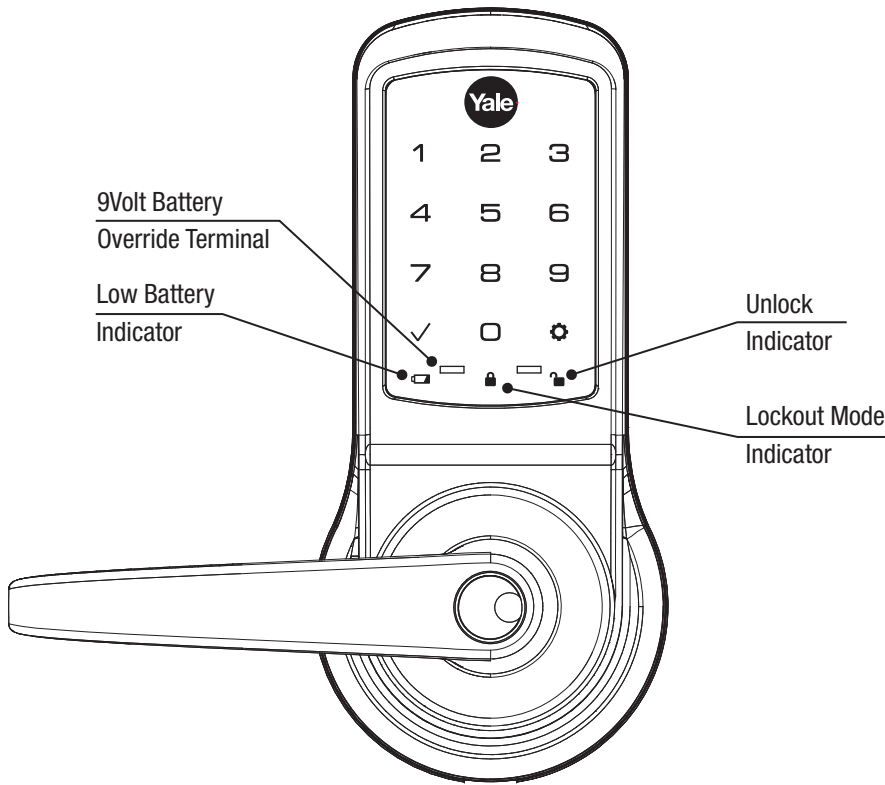

Exterior Escutcheon

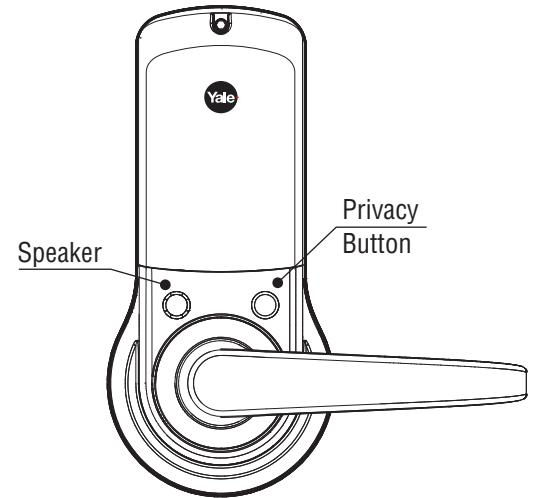

Interior Escutcheon

Lock Activation

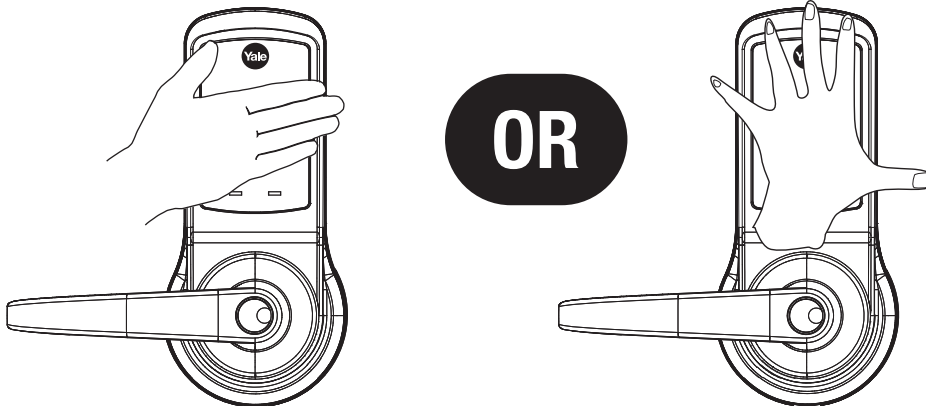

Master PIN Code must be created before any further programming.
Max User Codes = 500

1

Creating Master PIN Code

Creating a Master PIN Code must be performed upon installation or after resetting the lock to factory default. Programming and use of lock is not possible until this step has been successfully completed.

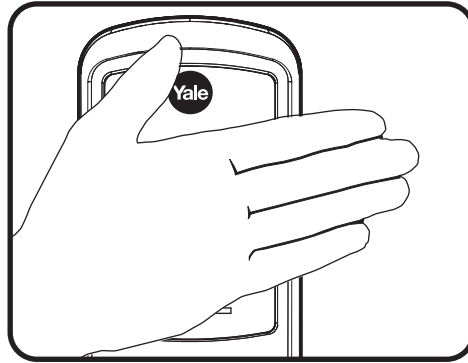

Press ⚙

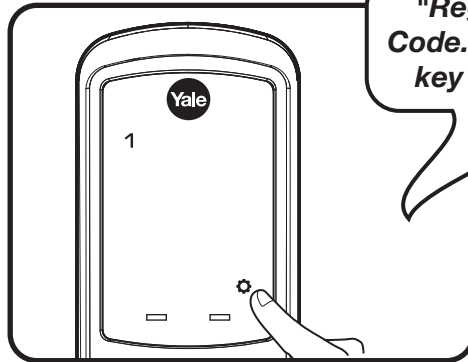

"Register Master Code. Press the gear key to continue."

Enter 4-8 digit Master PIN Code.

Press ⚙

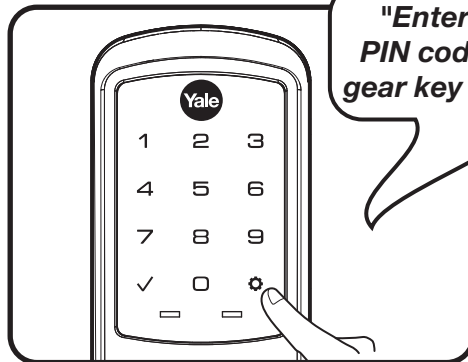

"Enter a 4-8 digit PIN code. Press the gear key to continue."

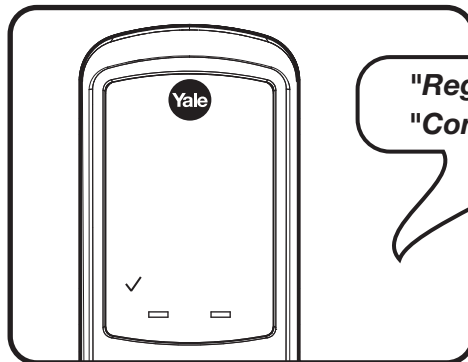

*"Registered."
"Completed."*

2

Creating User PIN Codes

Master PIN code must be created first.

*Max User Codes = 500

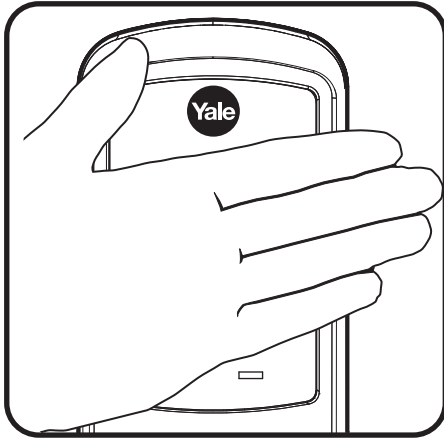

Enter Master PIN code

Press ⚙

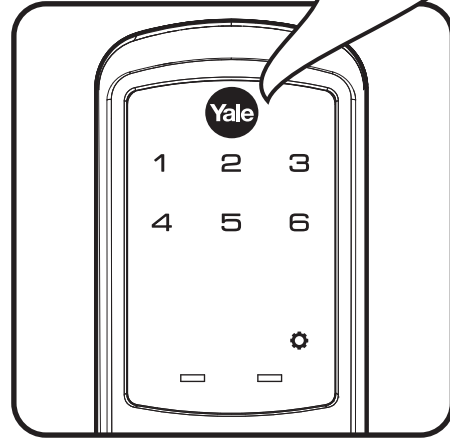
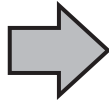

"Menu Mode, enter number."

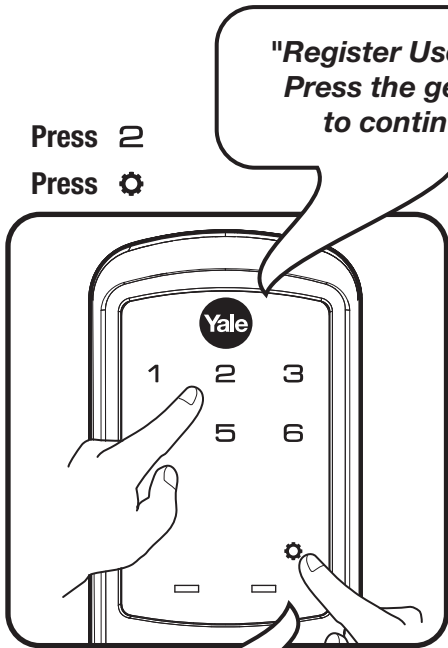

Press 2
Press ⚙

"Register User code. Press the gear key to continue."

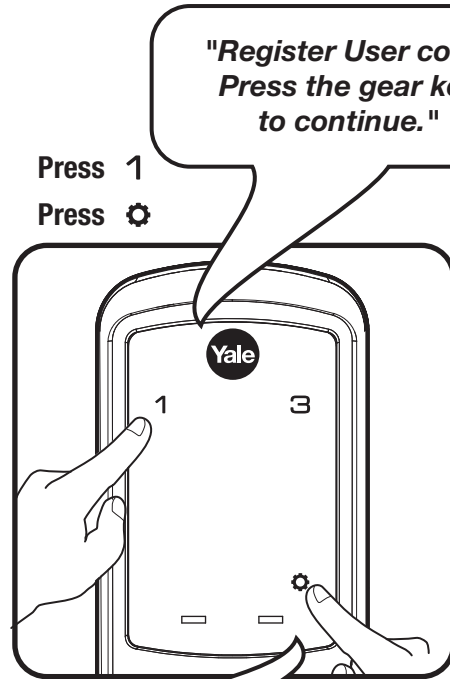

Press 1
Press ⚙

"Register User code. Press the gear key to continue."

"Press 1 to register a code."

"PIN code registration. Enter a 4-8 digit PIN code. Press the gear key to continue."

2

Creating User PIN Codes con't

Enter 4-8 digit PIN code
followed by ⚙

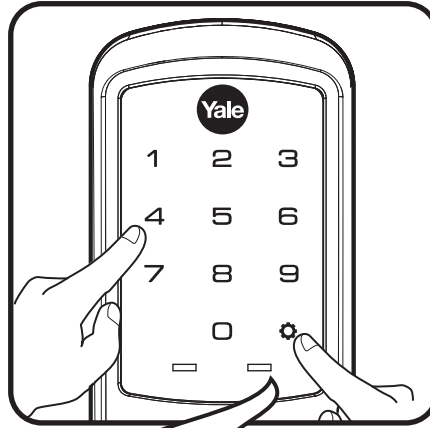

**"Registered.
Press the check key to
complete. Press the gear
key to continue."**



Adding more User Codes:

Press ⚙
Enter 4-8 digit PIN code
Press ⚙

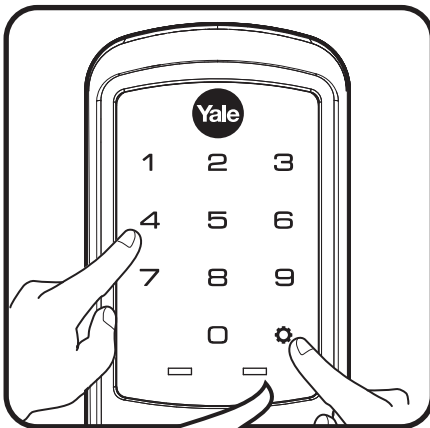

**"Registered.
Press the check key to
complete. Press the gear
key to continue."**

To end programming:

Press ✓

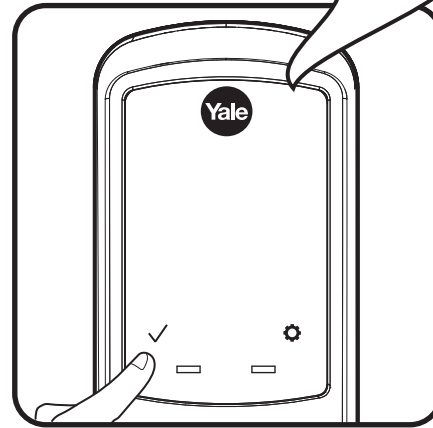

"Completed."

3

Locking & Unlocking Door with Registered Master or User PIN Code

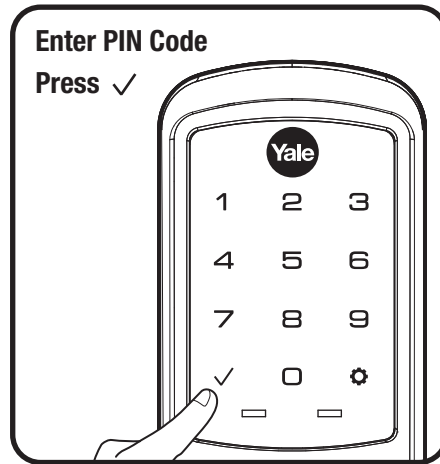



Testing Outside Lever Operation

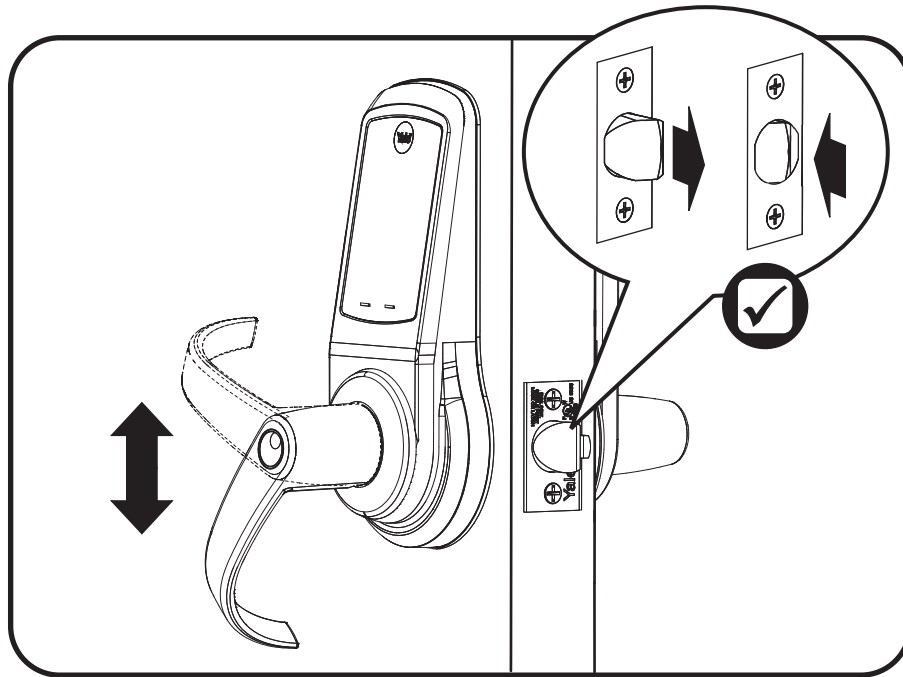

4

Locking Door with Privacy Button

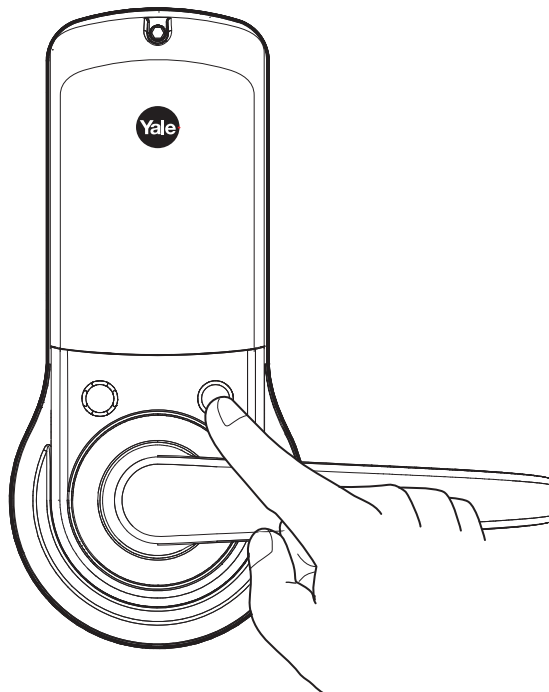

Resetting Lock to Factory Default

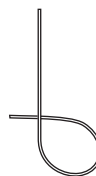
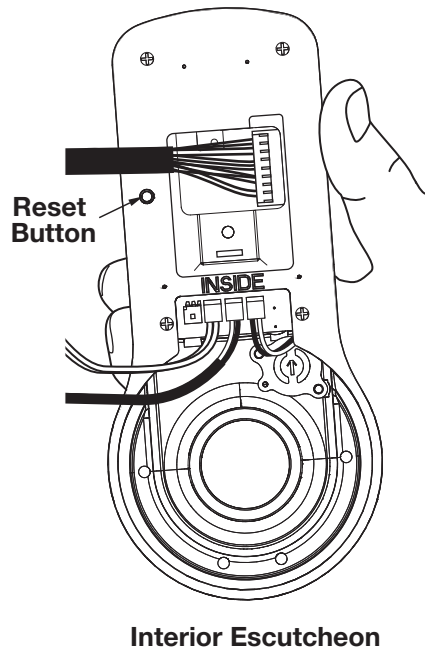

Lever Removal Tool

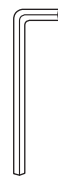

Hex Wrench

When lock is reset to factory defaults all user codes (including the Master PIN code*) are deleted and all programming features are reset to original default settings (see Factory Settings).

IMPORTANT: The outside assembly remains assembled.

1. Remove inside lever with the supplied lever removal tool.
2. Remove the battery cover with supplied hex wrench and then remove batteries.
3. Remove the 10-32 x 3/4" pan head screw from the center of the battery housing.
4. Remove the interior escutcheon from the door to access the reset button on back of escutcheon. Cables may stay connected. (See illustration at above for location of the reset button.)
5. Reinstall four (4) AA batteries.
6. Press the reset button for 3 seconds.
7. While continuing to press the reset button, temporarily remove one (1) AA battery.
8. Reinstall the battery.
9. Release reset button and wait approximately 15 seconds. Speaker will announce "Welcome to Yale."
10. Reassemble escutcheon by reversing steps 1-4.

Upon reset, Master PIN Code creation is the only option available and must be performed prior to any other programming of the lock.

Definitions

All Code Lockout Mode: This feature is enabled by the Master code. When enabled, it restricts all user (except Master) PIN code access. When attempting to enter a code while the unit is in Lockout, the RED locked padlock will appear on the screen. (Main Menu selection #6.)

Automatic Re-lock Time: After a successful unlock, the unit will re-lock automatically after 5 seconds or for a duration selected in the **Advanced Lock Settings** (Main Menu selection #3 then #1).

Language Setting Mode: Choose English (1), Spanish (2) or French (3) for the lock's voice prompts. (Main Menu selection #5.)

Low Battery: When battery power is low, the Low Battery Warning indicator flashes RED. If battery power is completely lost, use the 9Volt battery override. To use the 9V battery override apply 9V battery, in either direction, to terminals on the touchscreen for backup power option. Activate the touchscreen and enter your pin code to unlock the door.

Master PIN Code: The Master PIN code is used for programming and for feature settings. **It must be created prior to programming the lock.** The Master code will also operate (unlock/lock) the lock.

Network Module Setting: With the optional Network Module installed, this setting becomes available (Main Menu selection #7) and allows the lock to connect with a network controller.

One Touch Locking: When the unit is unlocked, activating the touchscreen will lock the unit (during Automatic Re-lock duration or when Automatic Re-lock is disabled). When One-Touch Re-lock is **not** in use (**disabled**), any valid PIN code will re-lock the lock. (Main Menu selection #3 then #3.)

Privacy Button to Lock Door: If Automatic Re-lock is disabled, a short 1 second press of this button will lock the door.

Privacy Mode: With optional Door Position Switch installed, Privacy Mode enabled thru Menu Mode and door closed, all keypad functions can be disabled with a 3 second press of the Privacy Button. Privacy Mode is disabled by default. Enable Privacy Mode thru Main Menu selection #3 then #4. With door closed, press and hold the privacy button until voice prompt indicates Privacy Mode is enabled. Privacy Mode duration ends when door is opened and voice prompt indicates Privacy Mode is disabled.

Shut Down Time: The unit will shut down for sixty (60) seconds and not allow operation after the wrong code entry limit (5 attempts) has been met. When the unit is in Shut down, the keypad will be flashing.

Tamper Alert: Audible alarm sounds if attempting to forcibly remove outside lock from door.

User PIN Code: The User code operates the lock. Maximum number of user codes is 500.

Volume Setting Mode: The volume setting for PIN code verification is set to **HIGH (1)** by default; otherwise it can be set to **Low (2)** or **Silent (3)** for quiet areas. (Main Menu selection #4.)

Wrong Code Entry Limit: After five (5) unsuccessful attempts at entering a valid PIN code, the unit will shut down and not allow operation. When the unit is in Shut Down, the keypad will be flashing.

Feature Programming Through Menu Mode Using Master PIN code*

1. Touch screen with back of hand or palm to activate.
2. Enter 4-8 digit master PIN code* followed by key.
Lock Response: "Menu mode, enter number (Enter digit corresponding to the function to be performed), press the key to continue."
3. Follow the voice commands.
4. Press key to complete the process and conclude the programming session.

*The Master PIN code must be registered prior to any other programming of the lock.

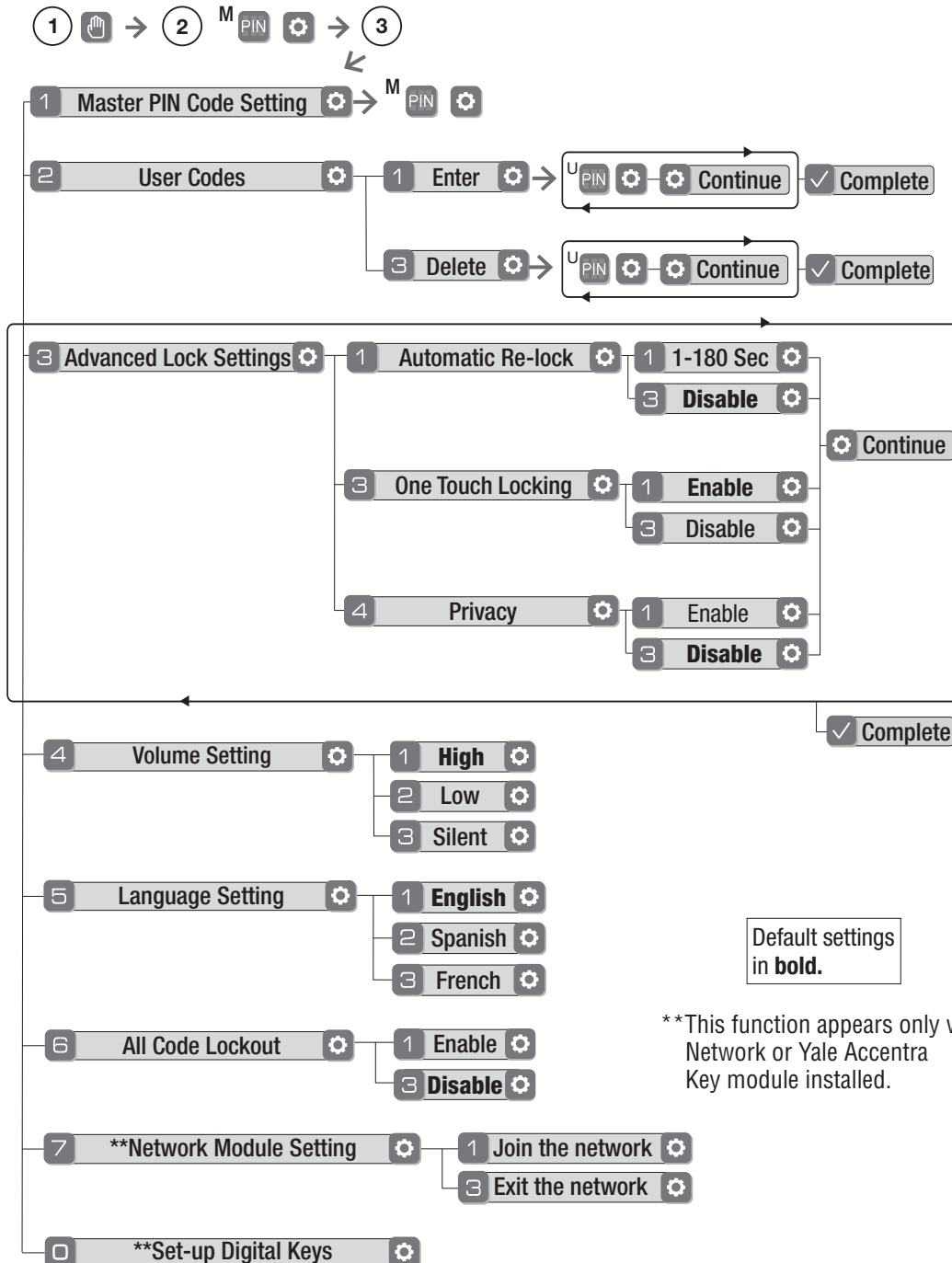

Programming Troubleshooting

Symptom	Suggested Action
Lock does not respond – door is open and accessible.	<ul style="list-style-type: none"> • Touchscreen becomes active when pressed w/whole hand. Use a larger area of the hand or fingers and verify contact with at least 3 areas. • If touchscreen numbers are visible, check to see if they respond when pressed. • Check batteries are installed and oriented correctly (polarity) in the battery case. • Check batteries are in good condition; replace batteries if discharged. • Check to see if touchscreen cable is fully connected and not pinched.
Lock does not respond – door is locked and inaccessible.	<ul style="list-style-type: none"> • Batteries may be completely discharged. • Apply 9V battery to terminals on the touchscreen for emergency power jump option.
Unit is on for a while then shows no reaction. Lights dim.	<ul style="list-style-type: none"> • Batteries do not have enough power. Replace batteries.
Unit chimes to indicate code acceptance, but the door will not open.	<ul style="list-style-type: none"> • Check for another locking device on the door (i.e. deadbolt). • Check the door gaps for any foreign objects between door and frame. • Check that the motor cable is firmly connected into the PC board marked "MOTOR".
Unit operates to allow access, but will not automatically re-lock.	<ul style="list-style-type: none"> • Check to see if Auto Re-lock Mode is enabled. • If low battery indicator is lit (see below), change batteries.
PIN codes will not register.	<ul style="list-style-type: none"> • PIN codes must consist of 4 to 8 digits to register. • The same PIN code cannot be used for multiple users. • Registration/management of PIN codes is set by the authority of the Master Code, which is set first. • Contact the Master user. • User codes must be entered within 20 seconds (while touchscreen is active) or process will have to be restarted. • Check ✓ or gear ⚙ cannot be used as part of the PIN code.
Upon entering a PIN code and pressing ✓ key, the unit displays "invalid code" error or lock times out without responding.	<ul style="list-style-type: none"> • Check to see if All Code Lockout Mode is enabled. • Only the Master can enable/disable Lockout Mode. Contact the Master user.
Upon entering a PIN code and pressing the ✓ key, the red padlock icon appears and there are different tones.	<ul style="list-style-type: none"> • Check to see if All Code Lockout Mode is enabled. • Only the Master can enable/disable Lockout Mode. Contact the Master user.
The unit operates, but it makes no sound.	<ul style="list-style-type: none"> • Check to see if Volume is set to Silent.
The unit responds "Low Battery"	<ul style="list-style-type: none"> • This is the alert to replace the batteries. Replace all four (4) batteries with new AA Alkaline batteries.
Upon entering a PIN code and pressing the ✓ key, the unit responds "Wrong number of digits".	<ul style="list-style-type: none"> • The digits entered were incorrect or incomplete. Re-enter 4-8 digits followed by the check ✓ key.

NOTE: When batteries are replaced, Network Module locks have a real time clock that will be set through the User Interface (UI); it is recommended to verify correct date and time particularly those locks operating under Daylight Saving Time (DST).

Hardware Troubleshooting

Cycle lock in both the locked and unlocked positions. If problems are found:

<p>Door is binding.</p> <ol style="list-style-type: none"> Check that door and frame are properly aligned and door is free swinging. Check hinges: They should not be loose or have excessive wear on knuckles.
<p>Latchbolt will not deadlock.</p> <ol style="list-style-type: none"> Either strike is out of alignment or the gap between door and jamb is too great. Realign strike or shim strike out towards flat area of latchbolt.
<p>Latchbolt does not retract or extend properly.</p> <p>Latchbolt tail and retractor are not properly positioned:</p> <ol style="list-style-type: none"> Remove lockset. Look through 2-1/8" hole and verify latchbolt tail is centered between top and bottom of hole. Remove latchbolt and insert lockset. Look through latchbolt hole and verify retractor mouth is centered in hole. If not, adjust outside rose plate. If necessary, rebore holes to line up retractor and tail.

Factory Settings

Settings	Factory Setting
Master PIN Code	Registration <i>required*</i>
Automatic Relock	5 Seconds
One Touch Locking	Enabled
Privacy Setting	Disabled
Volume Setting	High
Language	English
All Code Lockout Mode	Disabled
Wrong Code Entry Limit	5 Times
Shutdown Time	60 Seconds

*The Master PIN code must be registered prior to any other programming of the lock.

FCC:

NOTE: This equipment has been tested and found to comply with the limits for a Class B digital device, pursuant to part 15 of the FCC Rules. These limits are designed to provide reasonable protection against harmful interference in a residential installation. This equipment generates, uses and can radiate radio frequency energy and, if not installed and used in accordance with the instructions, may cause harmful interference to radio communications. However, there is no guarantee that interference will not occur in a particular installation. If this equipment does cause harmful interference to radio or television reception, which can be determined by turning the equipment off and on, the user is encouraged to try to correct the interference by one or more of the following measures:

- Reorient or relocate the receiving antenna.
- Increase the separation between the equipment and receiver.
- Connect the equipment into an outlet on a circuit different from that to which the receiver is connected.
- Consult the dealer or an experienced radio/ TV technician for help.

Warning: Changes or modifications to this device, not expressly approved by **Yale Security Inc.** could void the user's authority to operate the equipment.

Industry Canada:

This device complies with Industry Canada licence-exempt RSS standard(s). Operation is subject to the following two conditions: (1) this device may not cause interference, and (2) this device must accept any interference, including interference that may cause undesired operation of the device.

Le présent appareil est conforme aux CNR d'Industrie Canada applicables aux appareils radio exempts de licence. L'exploitation est autorisée aux deux conditions suivantes: (1) l'appareil ne doit pas produire de brouillage, et (2) l'utilisateur de l'appareil doit accepter tout brouillage radioélectrique subi, même si le brouillage est susceptible d'en compromettre le fonctionnement.

IMPORTANT! Tous les changements ou modifications pas expressément approuvés par la partie responsable de la conformité ont pu vider l'autorité de l'utilisateur pour actionner cet équipement.

Yale Locks & Hardware

Product Support Tel 800.810.WIRE (9473) • www.yalelocks.com

Yale Locks & Hardware is a division of Yale Security Inc., an ASSA ABLOY Group company.

nexTouch™ and Accentra™ are trademarks of Yale Security Inc., an ASSA ABLOY Group company.

Copyright © 2017, Yale Security Inc., an ASSA ABLOY Group company.

All rights reserved. Reproduction in whole or in part without the express written permission of Yale Security Inc. is prohibited.

YALE, with its unique global reach and range of products, is the world's favorite lock
–the preferred solution for securing your home, family and personal belongings.

ASSA ABLOY is the global leader in door opening solutions,
dedicated to satisfying end-user needs for security, safety and convenience.