

**REFRIGERATOR MANUFACTURER**  
**Turbo air**  
 more durable, efficient, beautiful

4184 E. Conant St.  
 Long Beach, CA 90808  
 Tel. 310-900-1000  
 Fax. 310-900-1077  
[www.turboairinc.com](http://www.turboairinc.com)

Project :	
Model # :	
Item # :	Qty :
Available W/H :	
Approval :	

## Solid Door Freezer

Reach-In Bottom Mount  
 Super Deluxe Series

**Model : TSF-49SD-N**

### FEATURES & BENEFITS

#### Self-Cleaning Condenser

The accumulation of dust in the condenser can cause the failure or breakdown of refrigerators. Refrigerators run normally until they reach a certain level of accumulation. At some point, when they are over the limit, their performance drops quickly resulting in damage to, or disposal of the stored products inside. The Self-Cleaning Condenser device keeps the condenser clean and prevents system failure by automatically brushing daily.

#### Digital temperature control & monitor system

- Keep food products safe by maintaining constant temperatures.
- Alarms that sound when doors are not sealed shut; protect against food spoilage that originates from cold air leaks.
- Early warning alarm program detects issues before malfunction occurs.
- Digital display allows for easy monitoring.
- Programs interpret the condition of refrigeration systems by self-diagnosis.
- Rapid cool-down function (Turbo Freeze).
- Smart defrost system will defrost as needed.
- Automatic evaporator fan motor delays.

#### Hydrocarbon refrigerants (R-290)

With innovative and eco-friendly technology, Turbo Air brings you hydrocarbon refrigerators designed to meet the new standards of the EPA and DOE in 2017. Hydrocarbon refrigerants do not deplete the ozone layer and have very low contribution to global warming (ODP-0, GWP-3).

#### Stainless steel cabinet construction

The Turbo Air Super Deluxe model boasts a stainless steel interior and exterior (galvanized steel top, bottom and back). It guarantees the utmost in cleanliness and long product life. Sharp corners and edges have been rounded to reduce the risk of injury. The Super Deluxe adds a touch of style to the most refined setting.

#### Sturdy, clean stainless steel shelving

Shelves are the most important part of cleanliness as they come in direct contact with food. After a while, PVC coated wire shelves may peel, rust and lead to unsanitary conditions. Only the Turbo Air Super Deluxe series uniquely provides stainless steel shelving.

#### Door pressure release device

Pressure relief doors are designed to eliminate vacuum pressure and allow easy, instant door opening.

#### High-density polyurethane insulation

The entire cabinet structure and solid doors are foamed-in-place using high density, CFC free polyurethane insulation.

#### LED interior lighting

#### Bottom mount compressor

#### Freezer holds -10°F ~ 0°F for the best in frozen food preservation



#### Patented Self-Cleaning Condenser



This product is equipped with a fine mesh filter to the front of the condenser to catch dust, and a rotating brush that moves up and down daily to remove excess buildup outward and away.

NATURAL Refrigerant

ISO 9001:2008

Intertek

Intertek

5 YEAR WARRANTY

Compressor 5 YEAR WARRANTY (U.S.A. only)

ENERGY STAR® Qualified

Model	Swing Door	CU./FT.	#of Shelves	HP	AMPS	Crated Weight (lbs.)	L x D x H* (inches)
TSF-49SD-N	2	39.9	6	2/3	5.5	457	54 <sup>3</sup> / <sub>8</sub> x 30 <sup>3</sup> / <sub>8</sub> x 78 <sup>1</sup> / <sub>4</sub>

# Solid Door Freezer

Reach-In Bottom Mount  
Super Deluxe Series

## Model : TSF-49SD-N

ELECTRICAL DATA	
Voltage	115/60/1
Plug Type	Ⓢ NEMA 5-15P
Full Load Amperes	5.5
Compressor HP	2/3
Feed Wires with Ground	3
Cord Length (ft.)	9
Refrigerant	R-290
DIMENSIONAL DATA	
# of Doors	2
# of Racks Accepted	2
Net Capacity (cu. ft.)	39.9
Ext. Length Overall (in.)	54 <sup>3</sup> / <sub>8</sub> (1382mm)
Ext. Depth Overall (in.)	30 <sup>3</sup> / <sub>8</sub> (770mm)
Ext. Height Overall (in.)*	78 <sup>1</sup> / <sub>4</sub> (1987mm)
Int. Length Overall (in.)	50 <sup>1</sup> / <sub>2</sub> (1283mm)
Int. Depth Overall (in.)	26 <sup>1</sup> / <sub>4</sub> (666mm)
Int. Height Overall (in.)	60 (1524mm)
Gross Weight (lbs.)	457
# of Shelves	6
Shelf Size (L x D) (in.)	24 <sup>1</sup> / <sub>2</sub> x 23 <sup>1</sup> / <sub>2</sub>

Design and specifications subject to change without notice.  
Actual shipping weight may differ due to extra packing materials for product protection.  
\* Height does not include 5" caster height or 6" optional legs.

### ■ WARRANTY : 3 Year Parts and Labor Warranty Additional 2 Year Warranty on Compressor

- Anti-corrosion coated evaporator
- Door locks standard
- Positive seal self-closing doors
- Easy replaceable one piece magnetic door gaskets
- Self-contained system
- Solid and sturdy grille design
- Standard 4" dia. swivel casters with locks on the front set
- Legs available (optional)
- Full and half pan racks available (optional)

### ■ OPTIONAL ACCESSORIES :

- 5" caster, 1/2" diameter & 13 TPI: M726500100 (non-brake), M726500200 (w/ brake)
- 6" stainless steel leg: 30221M0600
- Additional stainless steel shelf: 30278Q0200
- Half door bun tray rack: TSP-2224 (each holds up to six 18"L x 26"D sheet pans)
- Full door bun tray rack: TSP-2250 (each holds up to fifteen 18"L x 26"D sheet pans)

Ver.20171006

## PLAN VIEW

(unit : inch)

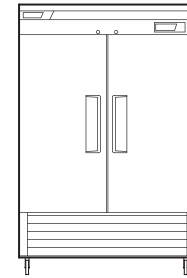

FRONT VIEW

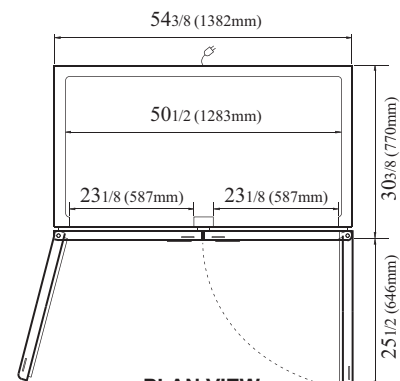

PLAN VIEW

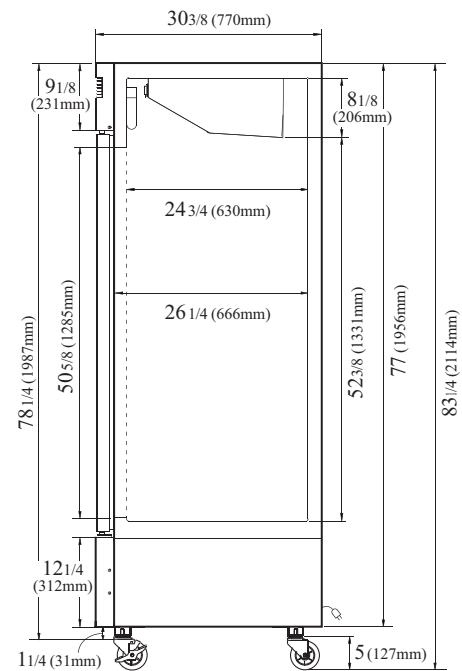

SIDE VIEW



- Turbo Air : 800-627-0032
- GK : 800-500-3519
- Warranty : 800-381-7770
- AC : 888-900-1002

