

**REFRIGERATOR MANUFACTURER**  
**Turbo air**  
 more durable, efficient, beautiful

4184 E. Conant St.  
 Long Beach, CA 90808  
 Tel. 310-900-1000  
 Fax. 310-900-1077  
[www.turboairinc.com](http://www.turboairinc.com)

|                 |       |
|-----------------|-------|
| Project :       |       |
| Model # :       |       |
| Item # :        | Qty : |
| Available W/H : |       |
| Approval :      |       |

## Sandwich / Salad Unit

Food Prep Tables  
**M3 Series**

### Patented Self-Cleaning Condenser



This product is equipped with a fine mesh filter to the front of the condenser to catch dust, and a rotating brush that moves up and down daily to remove excess buildup outward and away.

**Model : MST-48-N**



### ≡ FEATURES & BENEFITS ≡

- Self-Cleaning Condenser**  
 The accumulation of dust in the condenser can cause the failure or breakdown of refrigerators. Refrigerators run normally until they reach a certain level of accumulation. At some point, when they are over the limit, their performance drops quickly resulting in damage to, or disposal of the stored products inside. The Self-Cleaning Condenser device keeps the condenser clean and prevents system failure by automatically brushing daily.
- Digital temperature control & monitor system**  
 Keep food products safe by maintaining constant temperatures. External digital display allows for easy monitoring.
- Hydrocarbon refrigerants (R-290)**  
 With innovative and eco-friendly technology, Turbo Air brings you hydrocarbon refrigerators designed to meet the new standards of the EPA and DOE in 2017. Hydrocarbon refrigerants do not deplete the ozone layer and have very low contribution to global warming (ODP-0, GWP-3).
- Cold Bunker system**  
 Our innovative forced air system allows cold air to flow all around the food pan area, covering not only underneath the pan, but also the front, top and the rear. This unique air flow creates a cold air-shield around the pan, which maintains the food temperature at under 41°F (NSF requirement) even when the lids are opened. In addition, the compartment isolates pans from the reach-in area to prevent food spillage.
- Stainless steel cabinet construction**  
 The Turbo Air M3 model boasts a stainless steel exterior (galvanized steel back and bottom). Interior is AL interior with stainless steel floor and ABS door liner. It guarantees the utmost in cleanliness and long product life. The M3 model adds a touch of style to the most refined setting.
- High-density polyurethane insulation**  
 The entire cabinet structure and solid doors are foamed-in-place using high density, CFC free polyurethane insulation.
- Insulated pan cover**
- 9-1/2" deep, 1/2" thick high-density Polyethylene cutting board included with convenient side rail**
- Adjustable, heavy duty, PE (polyethylene) coated wire shelves**
- LED interior lighting**
- Refrigerator holds 33°F ~ 39°F for the best in food preservation**



| Model    | Swing Door | CU./FT. | #of Shelves | #of Pans | #of Hood | HP  | AMPS | Crated Weight (lbs.) | L x D* x H† (inches) |
|----------|------------|---------|-------------|----------|----------|-----|------|----------------------|----------------------|
| MST-48-N | 2          | 12      | 2           | 12       | 1        | 1/5 | 4.4  | 242                  | 48 1/4 x 30 x 37     |

## Model : MST-48-N

| ELECTRICAL DATA             |                 |
|-----------------------------|-----------------|
| Voltage                     | 115/60/1        |
| Plug Type                   | ⓘ NEMA 5-15P    |
| Full Load Amperes           | 4.4             |
| Compressor HP               | 1/5             |
| Cord Length (ft.)           | 9               |
| Refrigerant                 | R-290           |
| DIMENSIONAL DATA            |                 |
| Ext. Length Overall (in.)   | 48 1/4 (1226mm) |
| Ext. Depth Overall (in.) *  | 30 (762mm)      |
| Ext. Height Overall (in.) † | 37 (940mm)      |
| # of Doors                  | 2               |
| # of Shelves                | 2               |
| # of Pans                   | 12              |
| Net Capacity (cu. ft.)      | 12              |
| Net Weight (lbs.)           | 225             |
| Gross Weight (lbs.)         | 242             |
| Shelf Size (in.)            | 21 x 17         |

Design and specifications subject to change without notice.  
Actual shipping weight may differ due to extra packing materials for product protection.  
\* Depth does not include 1" for rear spacers.  
† Height does not include 5" for caster height.

■ **WARRANTY : 3 Year Parts and Labor Warranty**  
Additional 2 Year Warranty on Compressor

- **Anti-corrosion coated evaporator**
- **Self-contained system**
- **Standard 4" dia. swivel casters with locks on the front set**
- **Standard 1/6 size, 4" deep condiment pans included**
- **2.5" dia. casters available (optional) & Legs available (optional)**
- **Removable food covers available (optional)**
- **Stainless steel double overshelf available (optional)**

■ **OPTIONAL ACCESSORIES :**

- 2.5" caster, 1/2" diameter & 13 TPI: 30265H0100 (non-brake), 30265H0200 (w/ brake)
- 5" caster, 1/2" diameter & 13 TPI: M726500100 (non-brake), M726500200 (w/ brake)
- 6" ABS plastic leg: 30221M0200
- 6" stainless steel leg: 30221M0600
- Additional PE coated wire shelf: WM77800100
- Removable food cover: RCT-48
- Stainless steel double overshelf: TSOS-4R
- Door lock: extra lead time will apply, please call factory for more details to order**

Ver.20171010

## PLAN VIEW

(unit : inch)

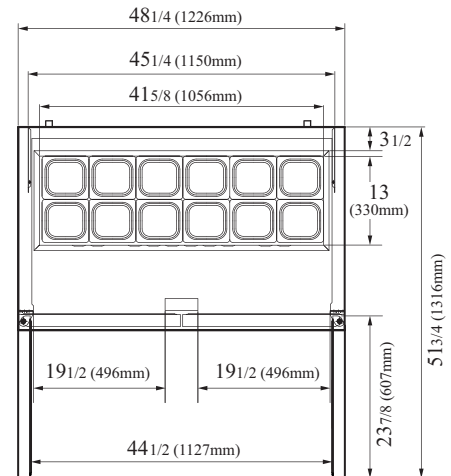

PLAN VIEW

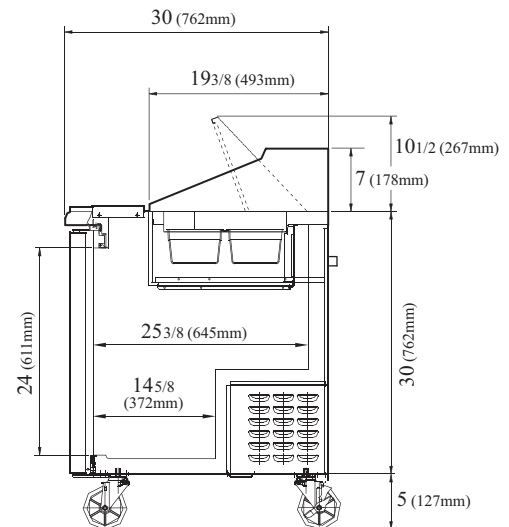

SIDE VIEW



- Turbo Air : 800-627-0032
- GK : 800-500-3519
- Warranty : 800-381-7770
- AC : 888-900-1002