

REFRIGERATOR MANUFACTURER
Turbo air
 more durable, efficient, beautiful

4184 E. Conant St.
 Long Beach, CA 90808
 Tel. 310-900-1000
 Fax. 310-900-1077
www.turboairinc.com

Project :	
Model # :	
Item # :	Qty :
Available W/H :	
Approval :	

Swing Door Freezers

Glass Door Merchandisers
 Super Deluxe Series

Model : TGF-5SD-N

≡ FEATURES & BENEFITS ≡

■ **Digital temperature control & monitor system**

- Keep food products safe by maintaining constant temperatures.
- Alarms that sound when doors are not sealed shut; protect against food spoilage that originate from cold air leaks.
- Early Warning Alarm program detect issues before malfunction occurs.
- Digital display allows for easy monitoring.
- Programs interpret the condition of refrigeration systems by self-diagnosis.
- Rapid cool-down function (Turbo freeze).
- Smart defrost system will defrost as needed.
- Automatic evaporator fan motor delays.

■ **Hydrocarbon refrigerants (R-290)**

With innovative and eco-friendly technology, Turbo Air brings you hydro-carbon refrigerators designed to meet the new standards of the EPA and DOE in 2017. Hydrocarbon refrigerants do not deplete the ozone layer and have very low contribution to global warming (ODP-0, GWP-3).

■ **No electrical cabinet heater is needed**

Turbo Air is the first in the industry to replace a frame heater with a method of using compressor-produced heat. This eliminates any unnecessary energy consumption while providing efficient freezing performance.

■ **High-density polyurethane insulation**

The entire cabinet structure is foamed-in-place using high density, CFC free polyurethane insulation.

■ **Triple pane heated glass doors**

Equipped with unique triple-pane heated glass doors which enhance energy efficiency by preventing heat transfers and minimizing condensation. Lightweight door construction reduces door maintenance, bushing wear, and facilitates smooth door opening.

■ **LED lighting interior**

■ **Freezer holds -10°F ~ 5°F for the best in frozen food preservation**



TGF-5SDB-N



TGF-5SDW-N



Model	Swing Door	CU./FT.	#of Shelves	HP	AMPS	Crated Weight (lbs.)	L x D* x H† (inches)
TGF-5SD-N	1	4.45	2	1/3	2.3	195	25 x 23 1/4 x 30 1/2

Swing Door Freezers

Glass Door Merchandisers
Super Deluxe Series

Model : TGF-5SD-N

ELECTRICAL DATA	
Voltage	115/60/1
Plug Type	ⓘ NEMA 5-15P
Full Load Amperes	2.3
Compressor HP	1/3
Cord Length (ft.)	7
Refrigerant	R-290
DIMENSIONAL DATA	
# of Doors	1
Net Capacity (cu. ft.)	4.45
Ext. Length Overall (in.)	25 (635mm)
Ext. Depth Overall (in.) *	23 1/4 (590mm)
Ext. Height Overall (in.) †	30 1/2 (775mm)
Int. Length Overall (in.)	20 5/8 (525mm)
Int. Depth Overall (in.)	18 3/4 (475mm)
Int. Height Overall (in.)	26 1/4 (665mm)
Net Weight (lbs.)	164
Gross Weight (lbs.)	195
# of Shelves	2
Shelf Size (L x D) (in.)	19 3/8 x 16 5/8

Design and specifications subject to change without notice.
Actual shipping weight may differ due to extra packing materials for product protection.

* Depth does not include 2-1/4" (57mm) for door handle.

Depth does not include 2-3/8" for rear mechanical component and additional 1-5/8" for a power cord bushing & radius of curvature.

† Height does not include 2-1/4" (56mm) for leg height.

- **WARRANTY : 3 Year Parts and Labor Warranty**
Additional 2 Year Warranty on Compressor

- **Anti-corrosion coated evaporator**

- **Door locks standard**

- **Two color options available (standard):** Super Deluxe series comes in white cabinet (W), black cabinet with black color trim (B).

OPTIONAL ACCESSORIES :

- Additional PE coated wire shelf: P0178A0300
- Price tag channel: P0122K5700 (18-1/2"L)

PLAN VIEW

(unit : inch)

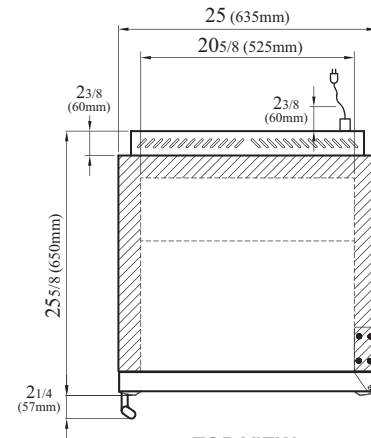

TOP VIEW

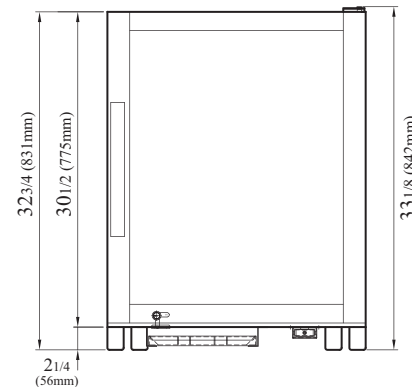

FRONT VIEW

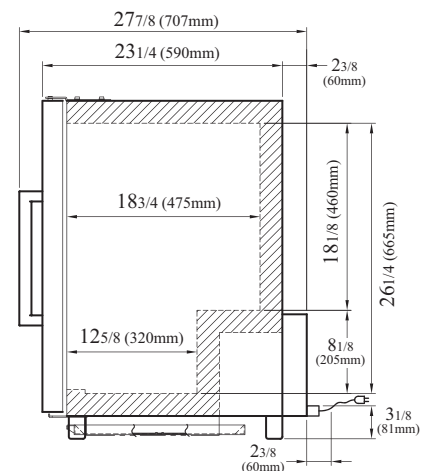

SIDE VIEW

Ver.20171127



- Turbo Air : 800-627-0032
- GK : 800-500-3519
- Warranty : 800-381-7770
- AC : 888-900-1002

