

REFRIGERATOR MANUFACTURER
Turbo air
 more durable, efficient, beautiful

4184 E. Conant St.
 Long Beach, CA 90808
 Tel. 310-900-1000
 Fax. 310-900-1077
www.turboairinc.com

Project :	
Model # :	
Item # :	Qty :
Available W/H :	
Approval :	

Swing Door Merchandisers

Glass Door Merchandisers
 Refrigerators

**Model : TGM-72RS
 TGM-72RSB**

FEATURES & BENEFITS

- **Energy conserving fan control**
 Utilizing algorithmic air circulation for optimal temperature levels, our innovative fan control system conserves energy by at least 15% and increases compressor life by up to 30%.
- **Hot gas condensate system** *Only Turbo Air models*
 Through Turbo Air's creative innovation, the condensate system surfaces have been specially treated to resist corrosion. This not only increases efficiency without the risk of refrigerant leakage from corrosion, but also prevents the overflow of condensate water.
- **LED advertising panel**
 LED lighting offers 5 times longer lasting life than fluorescents and conserves energy as well.
- **LED lighting interior**
 Brighter and longer lasting LED lights provide attractive, enhanced illumination compared to fluorescents. It saves energy by producing less heat, while maximizing the visibility in the display area.
- **Double pane glass doors with Low-E glass**
 Energy saving double pane glass doors are equipped with Low-emissivity glass, which reduce outer heat gain and decrease energy consumption. It enhances energy efficiency and minimizes condensation. Lightweight door construction also reduce door maintenance and bushing wear, which in turn facilitates smoother door openings.
- **Efficient refrigeration system**
 Turbo Air's glass door refrigerators are designed with oversized and balanced (CFC Free R-134A) refrigeration systems. These include efficient evaporators and condensers for faster cooling and greater efficiency.
- **Adjustable, heavy duty, PE (polyethylene) coated wire shelves**
- **Bottom mount compressor unit**
- **Ergonomically designed doors with easy grip handles**
- **Magnetic door gasket**
- **High-density polyurethane insulation**
 The entire cabinet structure is foamed-in-place using high density, CFC free polyurethane insulation.



Refrigerator holds 33°F ~ 38°F for the best in beverage preservation



Model	Swing Door	CU./FT.	#of Shelves	HP	AMPS	Crated Weight (lbs.)	L x D x H (inches)
TGM-72RS(B)	3	72	12	3/4	12	733	78 x 32 x 79 1/4

Model : TGM-72RS(B)

ELECTRICAL DATA	
Voltage	115/60/1
Plug Type	Ⓜ NEMA 5-15P
Full Load Amperes	12
Compressor HP	3/4
Cord Length (ft.)	7
Refrigerant	R-134A
DIMENSIONAL DATA	
# of Doors	3
Net Capacity (cu. ft.)	72
Ext. Length Overall (in.)	78 (1981mm)
Ext. Depth Overall (in.)*	32 (813mm)
Ext. Height Overall (in.)	79 1/4 (2013mm)
Int. Length Overall (in.)	74 3/8 (1895mm)
Int. Depth Overall (in.)	23 1/4 (590mm)
Int. Height Overall (in.)	61 5/8 (1539mm)
Net Weight (lbs.)	705
Gross Weight (lbs.)	733
# of Shelves	12
Shelf Size (L x D) (in.)	23 1/2 x 23
Bottle Capacity (Full/Load Line)	840 / 672

Design and specifications subject to change without notice.
Actual shipping weight may differ due to extra packing materials for product protection.
* Depth does not include 1-3/8" for door handle.

■ **WARRANTY : 2 Year Parts and Labor Warranty**
■ **Additional 3 Year Warranty on Compressor**

- **White and black color come standard**
- **4" dia. casters are available (optional)**
- **Price tag channel available (optional)**

■ **OPTIONAL ACCESSORIES :**

- 4" caster, 1/2" diameter & 13 TPI: G8F6500101 (non-brake), G8F6500201 (w/ brake)
- Additional PE coated wire shelf: 30278K0101
- Price tag channel: P0122K6000 (18 1/4"L)

PLAN VIEW

(unit : inch)

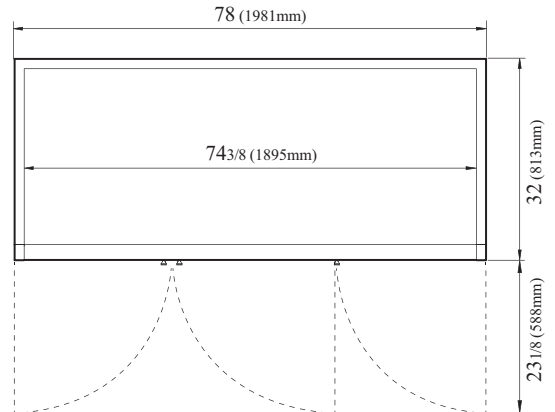

PLAN VIEW

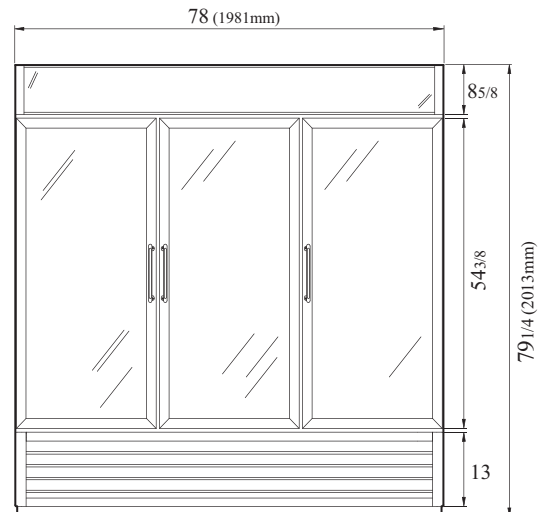

FRONT VIEW

Ver.201602

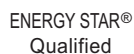

- Turbo Air : 800-627-0032
- GK : 800-500-3519
- Warranty : 800-381-7770
- AC : 888-900-1002

