

Project Name: _____ AIA#: _____

Model #: _____ Location: _____

SIS#: _____ Item #: _____ Quantity: _____



G-Series Medium Duty Automatic Slicer

Model G12A - 12" Diameter Knife



Enhanced features — improved slicing performance! Chute and endweight now accommodate 10.5" tall product. Pyramid-shaped end weight teeth and improved gripping teeth on underside of end weight for better hold when slicing longer product.



Standard Features

- Automatic or manual slicer operation
- 12" hard chromed special alloy, hollow ground knife, longer lasting and easier to sharpen
- Extended rod, end weight and chute can accommodate product up to 10.5" in length (1)
- Gripping teeth on underside of end weight for stability when slicing taller product (*inset* 2)
- Pyramid-shaped end weight teeth provide maximum product hold during slicing (3)
- 0 to 1/2" slice thickness
- Powerful 1/2 HP knife motor
- Motor overload protection with manual reset
- Oversized positive traction grooved belt drive
- Knife cover interlock
- Knob makes installation and removal of knife cover easier (*inset* 4)
- Top mounted all metal knife sharpener
- Removable easy-to-clean chute, slice deflector, and knife sharpener
- Anodized aluminum construction with seamless edges and radius corners
- Metal bottom base enclosure
- Permanently attached knife ring guard
- Moisture proof, easy-to-clean ON/OFF switch and knife hub
- Sealed splash zones for added sanitation and protection of electronics
- Ergonomically designed, dual purpose handle
- Easy movement with smooth stainless steel ball bearing chute slide
- 35° angled food chute
- No voltage release relay system
- Power indicator light
- Non-slip rubber feet

Warranty

- **One-year parts and labor**

Optional items

- Large slicer cover
- Cleaning brush

- Vegetable hopper
- Extended warranty

To select options, see complete list on back

Approved by: _____ Date: _____

2153 Dryden Rd., Dayton, OH 45439 | 937-299-5493 | 800-347-5423 | Fax: 937-299-4147 | www.globefoodequip.com



Front View

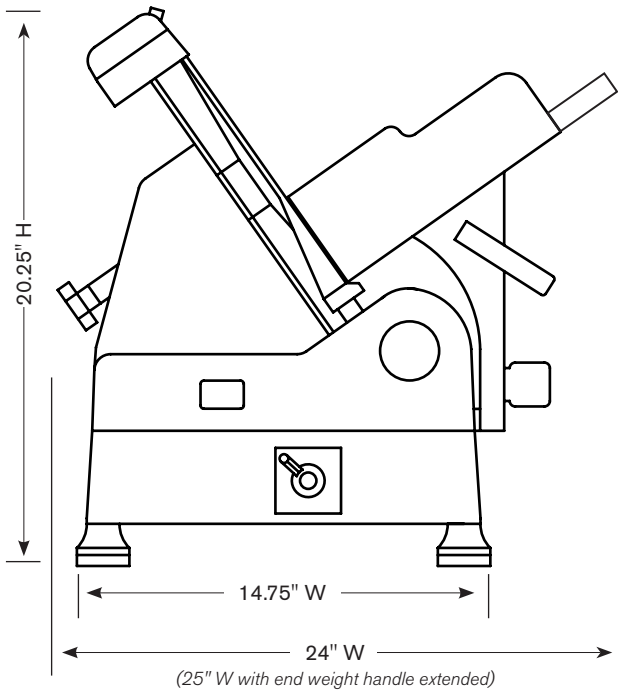

Side View

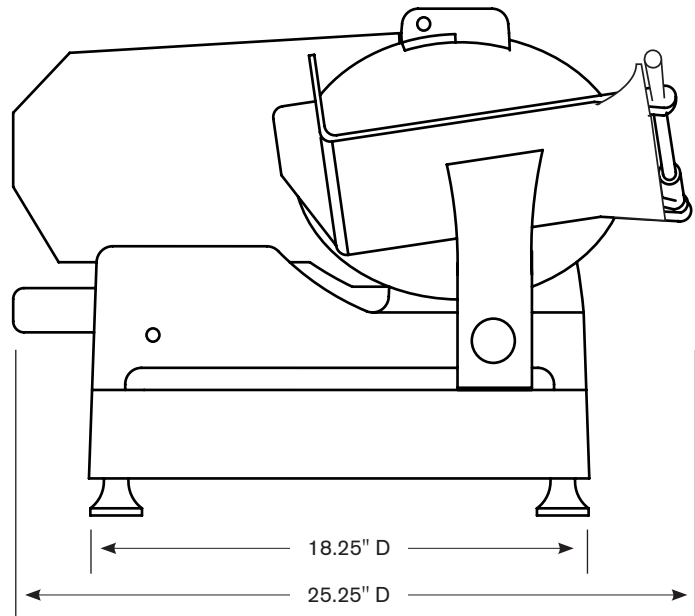

SPECIFICATIONS

Model	Auto or Manual	Motor	Volts	Amps	Drive Type	Slicing Volume per Day	Cheese Slicing	Blade Diameter	Max Slice	Product Cutting Capacity		
										W (Width)	D (Diameter)	H (Length)
G12A	Both	1/2 HP	115-60-1	3	Belt	2.5 Hours		12" (30.48 cm)	1/2" (1.3 cm)	10" (25.4 cm)	8.75" (22.2 cm)	8.25" (21 cm)

Cord & Plug: Attached 6 foot flexible 3-wire cord with molded plug fits a grounded receptacle. NEMA 5-15

DIMENSIONS | SHIPPING INFORMATION

Reinforced carton for shipping. The weight and dimensions of this reinforced carton are included below and may vary from shipment to shipment. **This product ships on a pallet. Freight class 85.**

Model	Base Foot Print	Overall Dimensions	Net Wt	Shipping Dimensions	Ship Wt
G12A	14.75" w x 18.25" d (37.5 cm x 49 cm)	25" w x 25.25" d x 20.25" h (64 cm x 64 cm x 51.4 cm)	81 lbs (37 kg)	25" w x 28" d x 32" h (64 cm x 71 cm x 81 cm)	88 lbs (40 kg)

Slicer is automatic or manual with 12" diameter hard chromed special alloy, hollow ground knife with stain resistant heavy-gauge anodized aluminum finish. Unit has 1/2 HP fan cooled motor with overload protection, manual reset, permanently lubricated ball bearings and positive traction grooved drive belt. Slicer has top mounted, removable, dual action knife sharpener with two stones, and removable food chute, slice deflector and knife cover. On/Off switch and electric wiring are moisture proof with sealed splash zones. Slicer is NSF and ETL listed. One-year parts and labor warranty.

OPTIONAL ITEMS:

- SC-LARGE** Large slicer cover
- CB** Cleaning brush
- A420VH** Vegetable hopper
- G-XDSLA** Extended warranty, extends factory warranty to 2 years on parts and labor in the continental U.S. **Available only at time of purchase.**