



BACK MOUNT SANDWICH PREP. TABLES

Back Mounted Condensing Unit

EPBN – Series

• EPBNR1 • EPBNSR2 • EPBNR2 • EPBNWR2 • EPBNR3

Cabinet Construction

Heavy duty stainless steel interior and exterior, galvanized steel finished bottom and back wall of exterior. High quality 16 gauge stainless steel worktop, top lid and hood. 2.5" thick high density foamed-in-place polyurethane insulation. Four 4" diameter casters (front casters with brakes). Door heater installation around inside cabinet frame to prevent moisture build-up.

Refrigeration System

- Back mounted condensing unit
- Oversized condenser and evaporator coil cools to set and maintain temperature in minimum time period
- Forced-air cooling with oversized evaporator fan motors providing balanced airflow throughout cabinet to ensure faster temperature drop
- Slide-out condensing unit for convenient repair and maintenance
- Front air breathing for built-in applications
- Environmentally friendly CFC free R-134A refrigerant
- Air defrost controlled by electrical timer
- Copper tube and aluminum fin evaporator with anti-corrosive coating
- Energy efficient condensate drain pan assembly heated by high side copper tube
- Pressure relief port located at exterior back wall for rapid re-entry
- Pre-wired and ready to plug, 115V/60Hz/1Ph, NEMA 5-15P

Doors

- Heavy duty stainless steel interior and exterior
- 2.5" thick high density foamed-in-place polyurethane insulation
- Rounded corners for a sleek and modern appearance
- Heavy duty adjustable torsion spring self-closing system
- One piece snap-in magnetic door gasket for easy replacement
- Heavy duty recessed door handles for a flat surface

Preparation Area

- 1/2" thick foam insulated lids to prevent moisture build-up and heat exchange
- Removable and adjustable sanitary 12 1/4" deep cutting board
- Sanitary PVC pans

Shelving

- Two epoxy coated wire shelves per section
- 304 stainless steel pilasters and shelf clips

Temperature Control

- Factory preset temperature, 35°F
- Temperature setting range from 33°F to 41°F
- Easy to read digital temperature display
- Easy to program push button temperature control
- Microchip digital monitoring system with a variety of functions to monitor and maintain optimum temperature
(Note: digital controls applied to models manufactured from April 2013)



EPBNR1



EPBNSR2



EPBNR2



EPBNWR2



EPBNR3

• Project / Customer _____

• Item No. _____

• Model No. _____

Warranty

2 Year — Parts & Labor
5 Year — Compressor



Please visit our website for updated Energy Efficiency information

201 W. Artesia Blvd, Compton, CA 90220
T. (310) 323-6586, (800) 444-6285 F. (310) 323-7524

www.EVERESTref.com

BACK MOUNT SANDWICH PREP TABLES

Back Mounted Condensing Unit



EVEREST
REFRIGERATION

EPBN – Series

• EPBNR1 • EPBNSR2 • EPBNR2 • EPBNWR2 • EPBNR3

Dimensions

SIDE VIEW

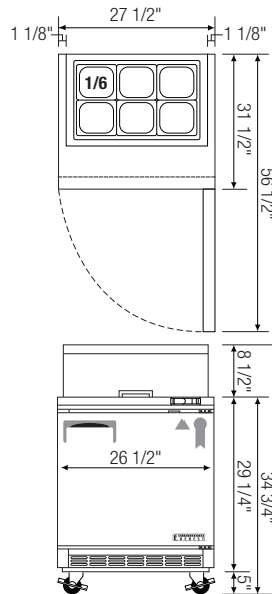
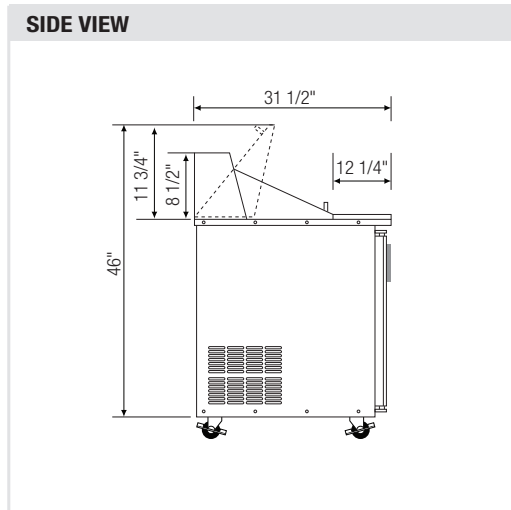

▲ EPBNR1

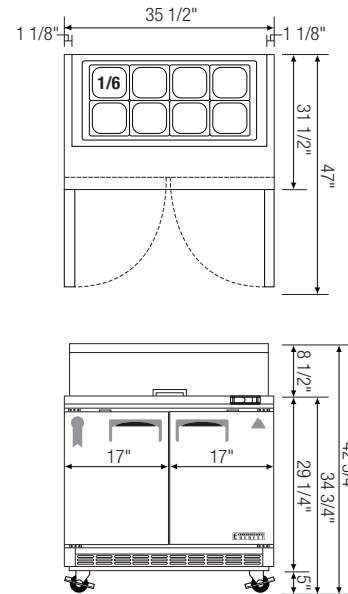

▲ EPBNSR2

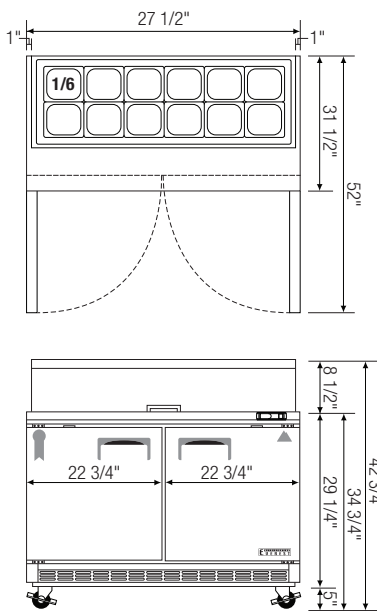

▲ EPBNR2

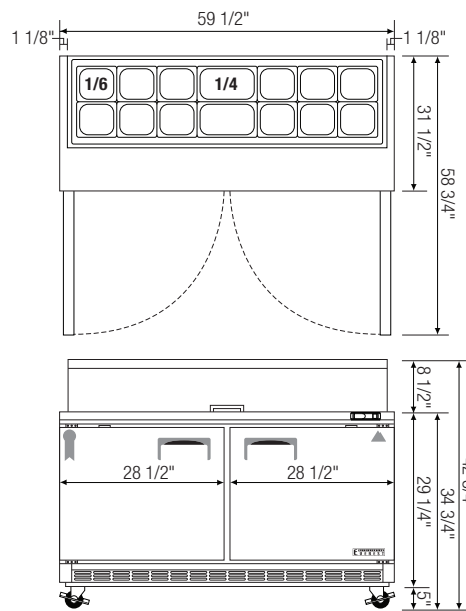

▲ EPBNWR2

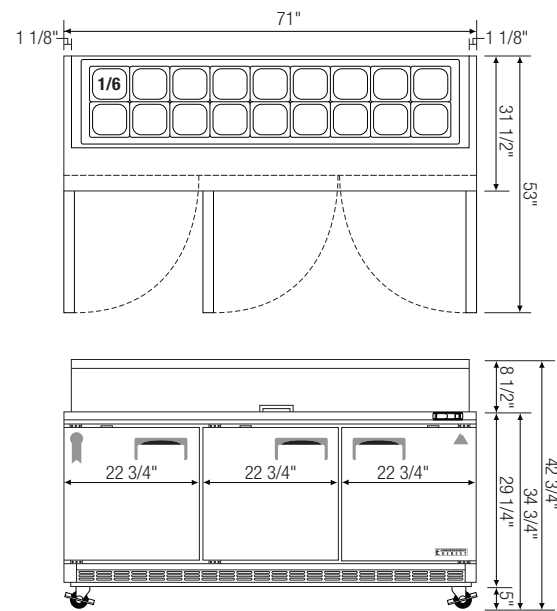

▲ EPBNR3

Model	Ref/ Fzr/ Dual	# of Doors	Capacity (Cu.Ft.)	HP	Refrigerant	# of Shelves	# of Pans	Power (V-Hz-Ph)	Amps	Crated Weight (LBS)	Exterior Dimensions (Inches)			* Height does not include 5" for caster. Ref = Refrigerator Fzr = Freezer Dual = Ref & Fzr Combo
											L	D	H *	
EPBNR1	Ref	1	6.5	1/5	R-134A	1	1/6 X 6	115-60-1	4.00	227	27 1/2	31 1/2	37 3/4	
EPBNSR2	Ref	2	8.5	1/5	R-134A	2	1/6 X 8	115-60-1	4.20	278	35 1/2	31 1/2	37 3/4	
EPBNR2	Ref	2	11.8	1/4	R-134A	2	1/6 X 12	115-60-1	4.20	317	47 1/2	31 1/2	37 3/4	
EPBNWR2	Ref	2	15	1/3	R-134A	2	1/6 X 12 1/4 X 2	115-60-1	5.01	357	59 1/2	31 1/2	37 3/4	
EPBNR3	Ref	3	18.3	1/3	R-134A	3	1/6 X 18	115-60-1	5.20	428	71	31 1/2	37 3/4	

Specifications subject to change without notice.

www.EVERESTref.com

201 W. Artesia Blvd, Compton, CA 90220
T. (310) 323-6586, (800) 444-6285 F. (310) 323-7524