

EBB – Series

• EBB23 • EBB59 • EBB69 • EBB90

Cabinet Construction

Heavy duty stainless steel countertop, and textured and laminated black vinyl exterior. Galvanized steel interior wall, and high quality stainless steel floor. 1 3/4" thick high density foamed-in-place polyurethane insulation. Pre-installed four 4" diameter casters for single door unit. Door heater installation around inside cabinet frame to prevent moisture build-up.

Refrigeration System

- Back mounted condensing unit for single door, and side mounted condensing unit for two and three door models
- Oversized condenser and evaporator coil cools to set and maintain temperature in minimum time period
- Forced-air cooling with oversized evaporator fan motors providing balanced airflow throughout cabinet to ensure faster temperature drop
- Removable side panel and slide-out condensing unit for convenient repair and maintenance
- Environmentally friendly CFC free R-134A refrigerant
- Air defrost controlled by electrical timer
- Copper tube and aluminum fin evaporator with anti-corrosive coating
- Energy efficient condensate drain pan assembly heated by high side copper tube
- Pre-wired and ready to plug, 115V/60Hz/1Ph, NEMA 5-15P

Doors

- Textured and laminated black exterior and galvanized steel interior
- 1 3/4" thick high density foamed-in-place polyurethane insulation
- One piece snap-in magnetic door gasket for easy replacement
- Heavy duty recessed door handles for a flat surface
- Door locks

Lighting

- Fluorescent interior lighting with on/off switch (except model EBB23)

Shelving

- Two epoxy coated wire shelves per section
- 304 stainless steel pilasters and shelf clips

Temperature Control

- Factory preset temperature, 35°F
- Temperature setting range from 33°F to 41°F
- Easy to set dial thermostat knob
- Easy to read digital temperature display
- Easy to program push button temperature control
- Microchip digital monitoring system with a variety of functions to monitor and maintain optimum temperature
(Note: digital controls applied to models manufactured from April 2013)

Option

- 2 1/2" and 4" diameter casters (3" and 5" overall height)



EBB23



EBB59



EBB69



EBB90

• Project / Customer _____

• Item No. _____

• Model No. _____

Warranty

2 Year — Parts & Labor
5 Year — Compressor



Please visit our website for updated
Energy Efficiency information

201 W. Artesia Blvd, Compton, CA 90220
T. (310) 323-6586, (800) 444-6285 F. (310) 323-7524

www.EVERESTref.com

BACK BAR COOLERS



EBB – Series

• EBB23 • EBB59 • EBB69 • EBB90

Dimensions

SIDE VIEW (All models except EBB23)

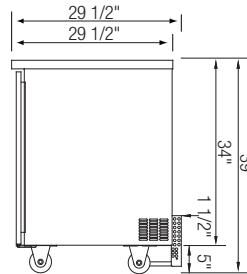
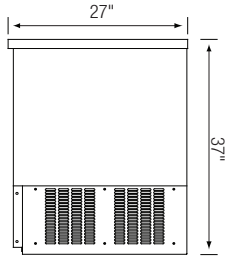

Pre-installed casters

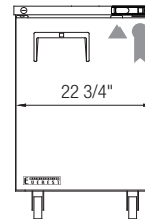

▲ EBB23

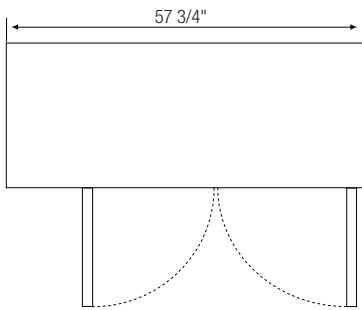
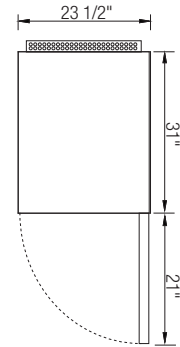

▲ EBB59

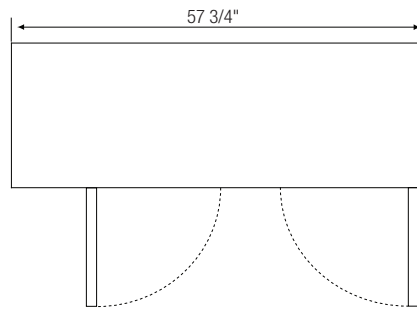

▲ EBB69

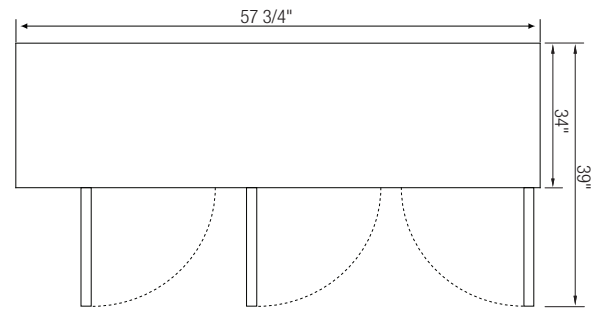

▲ EBB90

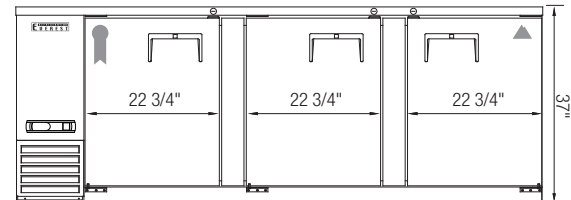
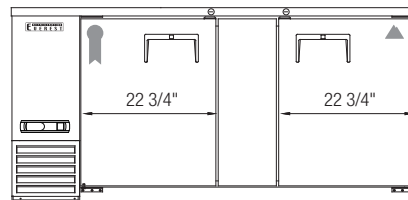
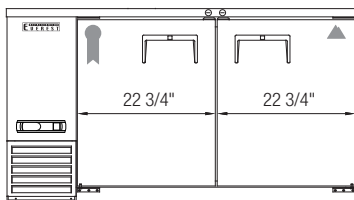

Model	Ref/ Fzr/ Dual	# of Doors	Capacity (Cu.Ft.)	HP	Refrigerant	# of Shelves	Power (V-Hz-Ph)	Amps	Crated Weight (LBS)	Exterior Dimensions (Inches)			* Height does not include 5" for caster. † Depth includes 1 1/2" for condensing coil. Ref = Refrigerator Fzr = Freezer Dual = Ref & Fzr Combo H = Half Door
										L	D	H	
EBB23	Ref	1	8.19	1/6	R-134A	2	115-60-1	3.90	154	23 1/2	31 [†]	39 [*]	
EBB59	Ref	2	20.09	1/4	R-134A	4	115-60-1	4.20	278	57 3/4	27	37	
EBB69	Ref	2	24.01	1/4	R-134A	4	115-60-1	4.20	309	68	27	37	
EBB90	Ref	3	32.37	1/3	R-134A	6	115-60-1	4.50	384	89 1/4	27	37	

Specifications subject to change without notice.

www.EVERESTref.com

201 W. Artesia Blvd, Compton, CA 90220
T. (310) 323-6586, (800) 444-6285 F. (310) 323-7524