



ATOSA CATERING EQUIPMENT INC.

WE MAKE THE KITCHEN BETTER

Stock Pot Stove



ATSP-18-1

ATSP-18-2



Standard Features

- ◆ NEW full width, removable stainless steel drip pan for easy cleanup
- ◆ Compact, heavy duty chassis for a long life span
- ◆ Stainless steel sides and front valve cover
- ◆ Stainless steel tubing for pilots
- ◆ One year limited warranty, parts and labor
- ◆ Heavy, cast iron three-ring burner, rated at a total of 80,000 BTU/hr
- ◆ Burner is equipped with two continuous pilots strategically placed for instant ignition of each section
- ◆ Two Manual controls to operate the inner and outer rings independently, for maximum flexibility of usage
- ◆ Heavy duty Cast iron top grated

Plan View

ATSP-18-1

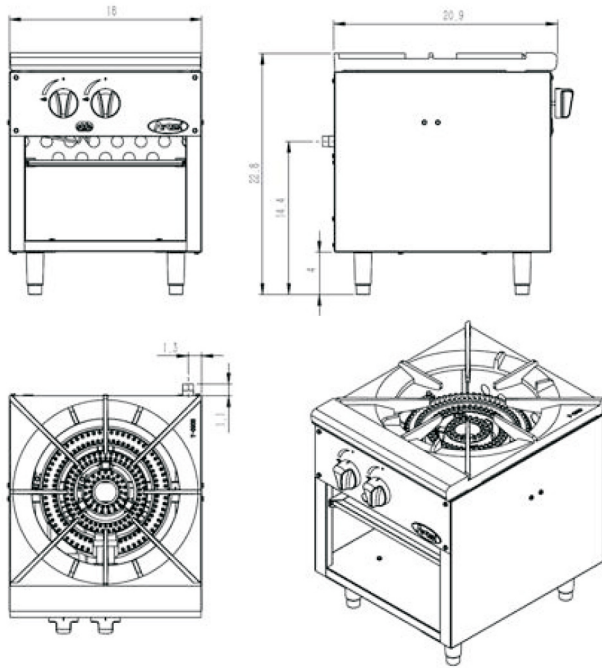

ATSP-18-2

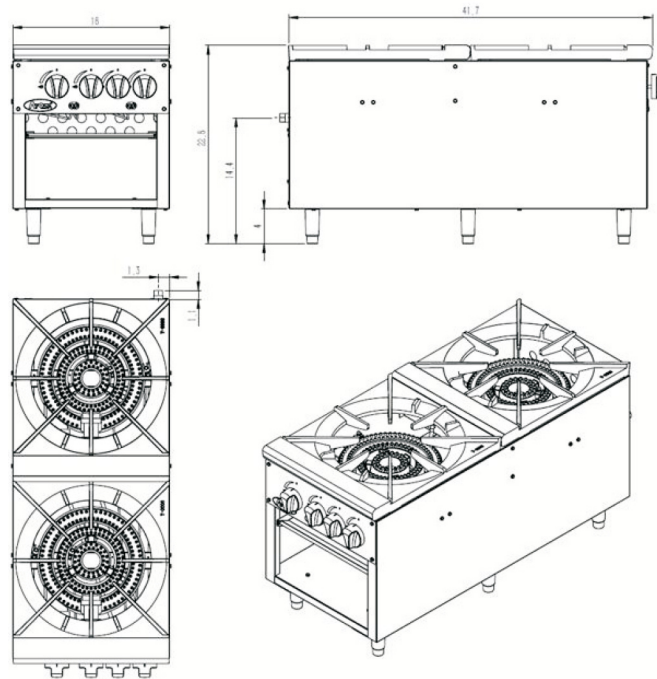

Conforms to ANSI
STD Z83.11b-2009(2011)
Certified to CSA
STD 1.8b-2009(2011)
Conforms to NSF/ANSI STD.4

Specifications

Model	Burners and Control Method	Gas Type	Intake-tube Pressure (in.W.C.)	B.T.U./h Per BTU B.T.U./h	B.T.U./h Total BTU B.T.U./h	Nozzle No.	Kg Net Weight (LBS)
ATSP-18-1	1 burners Independent control	NG	4	40,000	80,000	#32	105.8
		LP	10	40,000	80,000	#49	
ATSP-18-2	2 burners Independent control	NG	4	40,000	160,000	#32	201.7
		LP	10	40,000	160,000	#49	