

# DRAWERED SANDWICH PREP. TABLE

Back Mounted Condensing Unit

EPBN – Series

Model : EPBNR2-D4



**EVEREST**  
www.EVERESTref.com



 **Operating temperature range is 32°F ~ 42°F**



Please visit our website for updated Energy Efficiency information.

## Cabinet Construction

Heavy duty stainless steel interior and exterior, galvanized steel finished bottom and back wall of exterior. High quality 16 gauge stainless steel worktop, top lid and hood. 2.5" thick high density foamed-in-place polyurethane insulation. Four 4" diameter casters (front casters with brakes). Drawer heater installed around inside cabinet frame to prevent moisture build-up.

## Refrigeration System

- Back mounted condensing unit
- Oversized condenser and evaporator coils quickly achieve and maintain desired temperature
- Forced-air cooling with oversized evaporator fan motors providing balanced airflow throughout cabinet to ensure faster temperature drop
- Slide-out condensing unit for convenient repair and maintenance
- Front air breathing for built-in applications
- Environmentally friendly CFC free R-134A refrigerant
- Air defrost controlled by electrical timer
- Copper tube and aluminum fin evaporator with anti-corrosive coating
- Energy efficient condensate drain pan assembly heated by high side copper tube
- Pressure relief port for rapid cabinet re-entry
- Pre-wired and ready to plug, 115V/60Hz/1Ph, NEMA 5-15P

## Drawers

- Heavy duty stainless steel interior and exterior
- 2.5" thick high density foamed-in-place polyurethane insulation
- One piece snap-in magnetic drawer gaskets for easy replacement
- Heavy duty recessed drawer handles for a flat surface
- Heavy duty 304 stainless steel drawer frames with low-friction ball bearing slides  
*(Note: refer to the website for pan configurations)*

## Preparation Area

- 1/2" thick foam insulated lids to prevent moisture build-up and heat exchange
- Removable and adjustable sanitary 12 1/4" deep cutting board
- Sanitary polycarbonate pans *(Note: refer to the website for pan configurations)*

## Temperature Control

- Factory preset temperature, 35°F
- Temperature setting range from 32°F to 42°F
- Easy to set analog thermostat

## Option

- 2 1/2" diameter casters (3 1/2" overall height)

Model	# of Drawers	Capacity (Cu. Ft.)	HP	Refrigerant	# of Pans (Top)	# of Pans (Drawer) <sup>†</sup>	Power (V-Hz-Ph)	Amps	Crated Weight	Exterior Dimensions		
										L	D	H <sup>*</sup>
EPBNR2-D4	4	11.8	1/4+	R-134A	1/6 x 12	1/2 x 4, 1/3 x 4 1/4 x 2, 1/6 x 2	115-60-1	5.20	364lbs (165.1kg)	47 1/2" (1206 mm)	31 1/2" (800 mm)	37 1/2" (740 mm)

<sup>†</sup> : Drawer pans are not included.

\* : Height does not include 5" for casters.

Specifications subject to change without notice.

Product dimensions are for general purposes and not absolute value. Product capacity (P) is calculated based on standard industry figures. Slight variations may exist. If dimensions and capacity are critical, please contact Everest Refrigeration.

# DRAWERED SANDWICH PREP. TABLE

Back Mounted Condensing Unit

EPBN – Series

Model : EPBNR2-D4



DIMENSIONAL DATA		
Net capacity cu. ft.	11.8 (334.1 cu l)	
Exterior (mm)	Length Overall in.	47 1/2" (1206)
	Depth Overall in.	31 1/2" (800)
	Height Overall in.*	37 1/2" (740)
Crated Weight	364lbs (165.1kg)	
# of Drawers	4	
# of Top Pans	1/6 x 12 (6" Deep)	
# of Drawer Pans †	Top 4" Deep	1/2 x 2, 1/3 x 2
		1/4 x 2, 1/6 x 2
	Bottom 6" Deep	1/2 x 2, 1/3 x 2
ELECTRICAL DATA		
Voltage (V-Hz-Ph)	115-60-1	
Full load amperes	5.20	
Feed wires with Ground	3	
Cord Length ft.	9	
REFRIGERATION DATA		
Refrigerant	R-134A	
Compressor H.P.	1/4+HP	
BTU/HR <sup>a</sup> (Kcal/h)	2075 (523)	
 Equipped with one NEMA 5-15P plug.		

Specifications subject to change without notice.

\* : Height does not include 5" for casters.

† : Drawer pans are not included.

a : Based on evaporating temperature of 23°F(-5°C) & Condensing temperature of 131°F(55°C).

## Dimensions inches (mm)

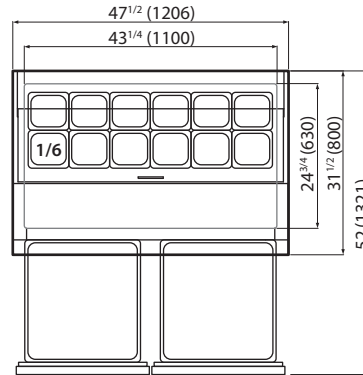

Top View

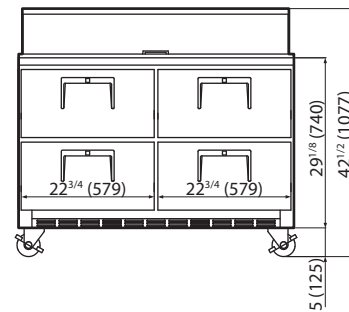
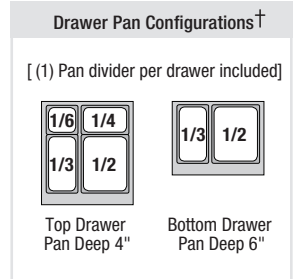

Front View

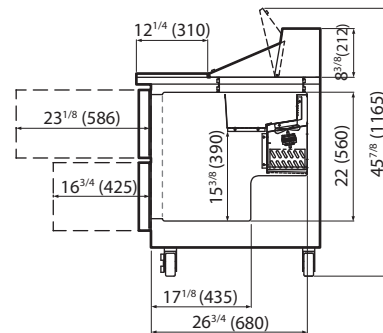

Side View