

**IMPORTANT!**  
DO NOT DESTROY

**¡IMPORTANTE!**  
NO DESTRUIR



# Installation and Maintenance Manual

with Safety Information  
and Parts List

RECOMMENDED SPARE PARTS HIGHLIGHTED IN GRAY

# Manual de Instalación y Mantenimiento

con Información sobre Seguridad  
y Lista de Refacciones

LAS REFACCIONES RECOMENDADAS SE RESALTAN EN GRIS

**Model 190-NSP Family**

Effective July 2015

(Supersedes March 2007)

Bulletin #677



Hytrol Conveyor Co., Inc.

Jonesboro, Arkansas

© COPYRIGHT 2005-HYTROL CONVEYOR CO., INC.

PRESS OPTIMIZED FOR THE ENVIRONMENT  
(IMPRESIÓN OPTIMIZADA PARA PROTEGER EL MEDIO AMBIENTE)

# TABLE OF CONTENTS

## INTRODUCTION

Receiving and Uncrating . . . . .	2
How to Order Replacement Parts . . . . .	2

## SAFETY INFORMATION . . . . . 3

## INSTALLATION

Support Installation . . . . .	4
Ceiling Hanger Installation . . . . .	4
Conveyor Set-Up . . . . .	4
Racked Sections . . . . .	4, 5
Electrical Equipment . . . . .	5

## OPERATION

Conveyor Start-Up . . . . .	5
-----------------------------	---

## MAINTENANCE

Lubrication . . . . .	5, 6
Drive Chain Alignment and Tension . . . . .	6
Trouble Shooting . . . . .	6
Maintenance Checklist . . . . .	Back Cover

## REPLACEMENT PARTS

190-NSP Parts Drawings . . . . .	7
190-NSP Parts List . . . . .	8
190-NSPC 90° Parts Drawings . . . . .	9
190-NSPC 90° Parts List . . . . .	10
190-NSPC 60° Parts List . . . . .	10
190-NSPC 60° Parts Drawings . . . . .	11
190-NSPC 45° Parts Drawings . . . . .	12
190-NSPC 45° Parts List . . . . .	13
190-NSPC 30° Parts List . . . . .	13
190-NSPC 30° Parts Drawings . . . . .	14
190-NSPS 45° Parts List . . . . .	15
190-NSPS 45° Parts Drawings . . . . .	16
190-NSPS 30° Parts List . . . . .	17
190-NSPS 30° Parts Drawings . . . . .	18
190-NSPSS 45° Parts List . . . . .	19
190-NSPSS 30° Parts List . . . . .	19
190-NSPSS 45° Parts Drawings . . . . .	20
190-NSPSS 30° Parts Drawings . . . . .	21

Spanish Version . . . . .	22
---------------------------	----

# INTRODUCTION

This manual provides guidelines and procedures for installing, operating, and maintaining your conveyor. A complete parts list is provided with recommended spare parts highlighted in gray. Important safety information is also provided throughout the manual. For safety to personnel and for proper operation of your conveyor, it is recommended that you read and follow the instructions provided in this manual.

## • Receiving and Uncrating

1. Check the number of items received against the bill of lading.
2. Examine condition of equipment to determine if any damage occurred during shipment.
3. Move all crates to area of installation.
4. Remove crating and check for optional equipment that may be fastened to the conveyor. Make sure these parts (or any foreign pieces) are removed.

**NOTE: If damage has occurred or freight is missing, Contact your Hytrol Integration Partner.**

## • How to Order Replacement Parts

Included in this manual are parts drawings with complete replacement parts lists. Minor fasteners, such as nuts and bolts, are not included.

When ordering replacement parts:

1. Contact Dealer from whom conveyor was purchased or nearest HYTROL Integration Partner.
2. Give Conveyor Model Number and Serial Number or HYTROL Factory Order Number.
3. Give Part Number and complete description from Parts List.
4. Give type of drive. Example—8" End Drive, 8" Center Drive, etc.
5. If you are in a breakdown situation, tell us.



HYTROL Serial Number  
(Located near Drive on Powered Models).

# SAFETY INFORMATION

## • Installation

### GUARDS AND GUARDING

Interfacing of Equipment. When two or more pieces of equipment are interfaced, special attention shall be given to the interfaced area to insure the presence of adequate guarding and safety devices.

Guarding Exceptions. Whenever conditions prevail that would require guarding under these standards, but such guarding would render the conveyor unusable, prominent warning means shall be provided in the area or on the equipment in lieu of guarding.

Guarded by Location or Position. Where necessary for the protection of employees from hazards, all exposed moving machinery parts that present a hazard to employees at their work station shall be mechanically or electrically guarded, or guarded by location or position.

- Remoteness from frequent presence of public or employed personnel shall constitute guarding by location.
- When a conveyor passes over a walkway, roadway, or work station, it is considered guarded solely by location or position if all moving parts are at least 8 ft. (2.44 m) above the floor or walking surface or are otherwise located so that the employee cannot inadvertently come in contact with hazardous moving parts.
- Although overhead conveyors may be guarded by location, spill guards, pan guards, or equivalent shall be provided if the product may fall off the conveyor for any reason and if personnel would be endangered.

### HEADROOM

- When conveyors are installed above exit passageways, aisles, or corridors, there shall be provided a minimum clearance of 6 ft. 8 in. (2.032 m) measured vertically from the floor or walking surface to the lowest part of the conveyor or guards.
- Where system function will be impaired by providing the minimum clearance of 6 ft. 8 in. (2.032 m) through an emergency clearance, alternate passageways shall be provided.
- It is permissible to allow passage under conveyors with less than 6 ft. 8 in. (2.032 m) clearance from the floor for other than emergency exits if a suitable warning indicates low headroom.

## • Operation

A) Only trained employees shall be permitted to operate conveyors. Training shall include instruction in operation under normal conditions and emergency situations.

B) Where employee safety is dependent upon stopping and/or starting devices, they shall be kept free of obstructions to permit ready access.

C) The area around loading and unloading points shall be kept clear of obstructions which could endanger personnel.

D) No person shall ride the load-carrying element of a conveyor under any circumstances unless that person is specifically authorized by the owner or employer to do so. Under those circumstances, such employee shall only ride a conveyor which incorporates within its supporting structure platforms or control stations specifically designed for carrying personnel. Under no circumstances shall any person ride on any element of a vertical conveyor.

E) Personnel working on or near a conveyor shall be instructed as to the location and operation of pertinent stopping devices.

F) A conveyor shall be used to transport only material it is capable of handling safely.

G) Under no circumstances shall the safety characteristics of the conveyor be altered if such alterations would endanger personnel.

H) Routine inspections and preventive and corrective maintenance programs shall be conducted to insure that all safety features and devices are retained and function properly.

I) Personnel should be alerted to the potential hazard of entanglement in conveyors caused by items such as long hair, loose clothing, and jewelry.

J) Conveyors shall not be maintained or serviced while in operation unless proper maintenance or service requires the conveyor to be in motion. In this case, personnel shall be made aware of the hazards and how the task may be safely accomplished.

K) Owners of conveyor should insure proper safety labels are affixed to the conveyor warning of particular hazards involved in operation of their conveyors.

**CAUTION!** Because of the many moving parts on the conveyor, all personnel in the area of the conveyor need to be warned that the conveyor is about to be started.

## • Maintenance

- All maintenance, including lubrication and adjustments, shall be performed only by qualified and trained personnel.
- It is important that a maintenance program be established to insure that all conveyor components are maintained in a condition which does not constitute a hazard to personnel.
- When a conveyor is stopped for maintenance purposes, starting devices or powered accessories shall be locked or tagged out in accordance with a formalized procedure designed to protect all persons or groups involved with the conveyor against an unexpected start.
- Replace all safety devices and guards before starting equipment for normal operation.
- Whenever practical, DO NOT lubricate conveyors while they are in motion. Only trained personnel who are aware of the hazard of the conveyor in motion shall be allowed to lubricate.

### Safety Guards

Maintain all guards and safety devices IN POSITION and IN SAFE REPAIR.

### Safety Labels

In an effort to reduce the possibility of injury to personnel working around HYTROL conveying equipment, safety labels are placed at various points on the equipment to alert them of potential hazards. Please check equipment and note all safety labels. Make certain your personnel are alerted to and obey these warnings. See Safety Manual for examples of warning labels.

**REMEMBER** Do not remove, reuse or modify material handling equipment for any purpose other than it's original intended use.

**CAUTION!** Only trained personnel should track a conveyor belt which must be done while conveyor is in operation. DO NOT attempt to track belt if conveyor is loaded.

# INSTALLATION

## • Support Installation

1. Determine primary direction of product flow. Figure 4A indicates the preferred flow as related to the drive.
2. Refer to "Match-Mark" numbers on ends of conveyor sections. (Figure 4A). Position them in this sequence near the area of installation.
3. Attach supports to both ends of drive section and to one end of intermediate or tail sections (Figure 4A). Hand tighten bolts only at this time.
4. Adjust elevation to required height.

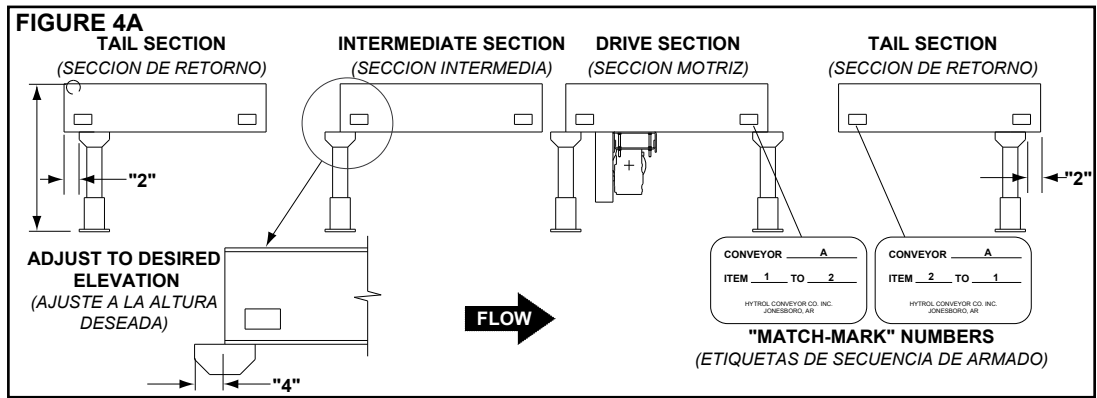

## • Ceiling Hanger Installation

If conveyors are to be used in an overhead application, ceiling hangers may have been supplied in place of floor supports. Figure 4B shows how a ceiling hanger mounts to a conveyor section. Ceiling hangers should be mounted at section joints. For safety information concerning conveyors mounted overhead, refer to "Installation Safety Precautions" on Page 3.

NOTE: When installing ceiling hanger rods in an existing building, all methods of attachment must comply with local building codes.

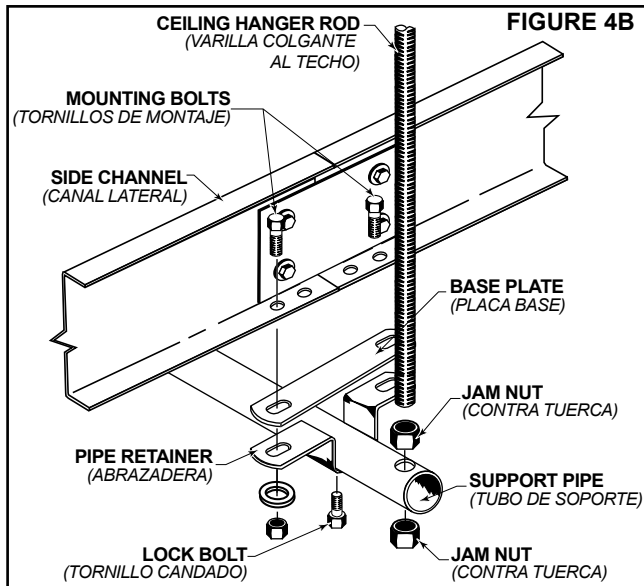

## • Conveyor Set-Up

1. Mark a chalk line on floor to locate center of the conveyor. (Floor Mounted Conveyors).
2. Place the drive section in position.
3. Install remaining sections, placing end without support on extended support of previous section (Figure 4A). Check "Match-Mark" Numbers to see that adjoining sections are in proper sequence.
4. Fasten sections together with splice plates and pivot plates (Figure 4D and 4E). Hand tighten bolts only at this time.
5. Check to see that conveyor is level across width and length of unit. Adjust supports as necessary.
6. Insure that all bed sections are square. Refer to Page 4-5 for instructions on "How to Square The Beds".
7. Tighten all splice plates and support mounting bolts and lag conveyor to floor.
8. Check to see that drive shafts are properly aligned at section joints. Misalignment of shafts will cause excessive wear to coupling chain and sprockets. Adjust coupling sprockets as shown in Figure 4D.
9. Install coupling chain.
10. Install shaft guards on 190-NSP and 190-NSPSS conveyors (Figure 4C). 190-NSPC and 190-NSPS are shipped with guards attached.
11. Install electrical controls and wire motor. See Page 5.

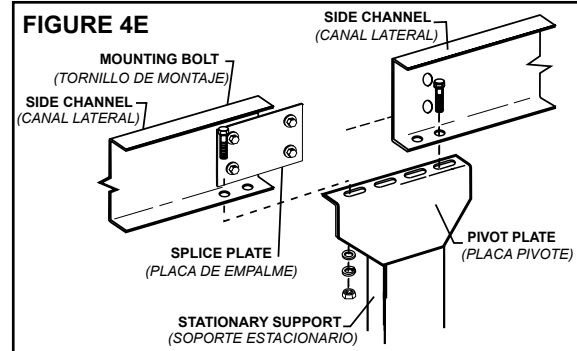
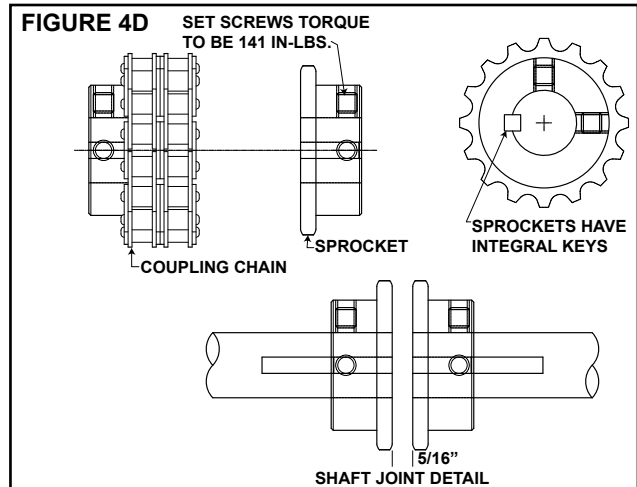
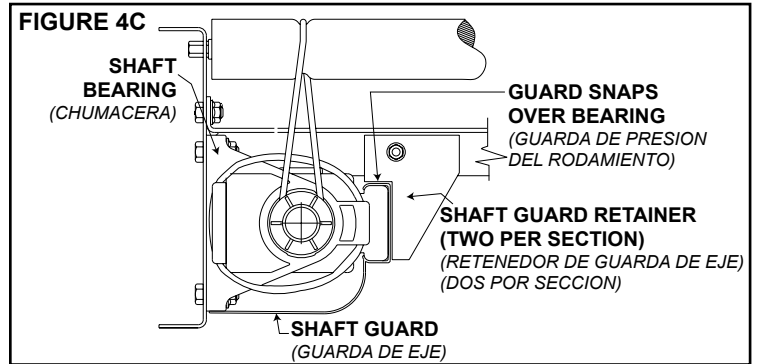

## • Racked Sections

It is important that each bed section be checked for a "racked" or out-of-square condition. If conveyor is not square, tracking problems will result. Figure 5A indicates a racked section.

### TO CORRECT AN OUT-OF-SQUARE SECTION

1. Locate points on corners of section and measure distance "A" & "B". If the dimensions are not equal, the section will need to be squared. (Figure 5B).
2. Use crossbracing supplied on underside of conveyor to square each section. Adjust turnbuckle until Dimensions "A" & "B" are equal.
3. After all bed sections have been checked and corrected for "racked condition", tighten all splice plates and pivot plate bolts.
4. Make final check to see that all conveyor sections are level across width and length. If entire conveyor is level, supports can be lagged to floor.

"Racked" conveyor sections will cause package to travel toward side of conveyor.

**IMPORTANT!** Being out of level across width of conveyor can cause package drift on long conveyor lines.

**NOTE:** Rods are positioned at the factory so they will square the bed section when tightened. It may be necessary to reposition the rod if the bed is out of square in the opposite direction.

## • Electrical Equipment

**WARNING!** Electrical controls shall be installed and wired by a qualified electrician. Wiring information for the motor and controls are furnished by the equipment manufacturer.

### CONTROLS

Electrical Code: All motor controls and wiring shall conform to the National Electrical Code (Article 670 or other applicable articles) as published by the National Fire Protection Association and as approved by the American Standards Institute, Inc.

### CONTROL STATIONS

A) Control stations should be so arranged and located that the operation of the equipment is visible from them, and shall be clearly marked or labeled to indicate the function controlled.

B) A conveyor which would cause injury when started shall not be started until employees in the area are alerted by a signal or by a designated person that the conveyor is about to start.

When a conveyor would cause injury when started and is automatically controlled or must be controlled from a remote location, an audible device shall be provided which can be clearly heard at all points along the conveyor where personnel may be present. The warning device shall be actuated by the controller device starting the conveyor and shall continue for a required period of time before the conveyor starts. A flashing light or similar visual warning may be used in conjunction with or in place of the audible device if more effective in particular circumstances.

Where system function would be seriously hindered or adversely affected by the required time delay or where the intent of the warning may be misinterpreted (i.e., a work area with many different conveyors and allied devices), clear, concise, and legible warning shall be provided. The warning shall indicate that conveyors and allied equipment may be started at any time, that danger exists, and that personnel must keep clear. The warnings shall be provided along the conveyor at areas not guarded by position or location.

C) Remotely and automatically controlled conveyors, and conveyors where operator stations are not manned or are beyond voice and visual contact from drive areas, loading areas, transfer points, and other potentially hazardous locations on the conveyor path not guarded by location, position, or guards, shall be furnished with emergency stop buttons, pull cords, limit switches, or similar emergency stop devices.

All such emergency stop devices shall be easily identifiable in the immediate vicinity of such locations unless guarded by location, position, or guards. Where the design, function, and operation of such conveyor clearly is not hazardous to personnel, an emergency stop device is not required.

The emergency stop device shall act directly on the control of the conveyor concerned and shall not depend on the stopping of any other equipment. The emergency stop devices shall be installed so that they cannot be overridden from other locations.

D) Inactive and unused actuators, controllers, and wiring should be removed from control stations and panel boards, together with obsolete diagrams, indicators, control labels, and other material which serve to confuse the operator.

### SAFETY DEVICES

A) All safety devices, including wiring of electrical safety devices, shall be arranged to operate in a "Fail-Safe" manner, that is, if power failure or failure of the device itself would occur, a hazardous condition must not result.

B) Emergency Stops and Restarts. Conveyor controls shall be so arranged that, in case of emergency stop, manual reset or start at the location where the emergency stop was initiated, shall be required of the conveyor(s) and associated equipment to resume operation.

**FIGURE 5A**

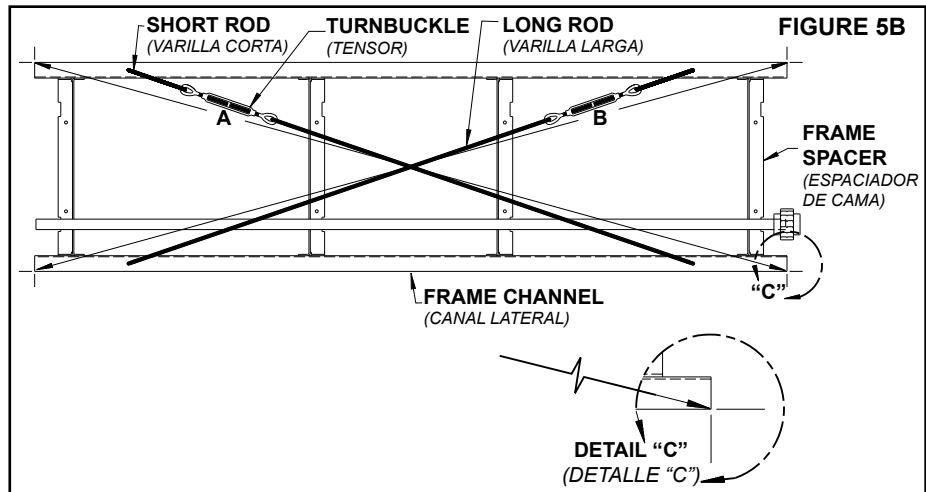
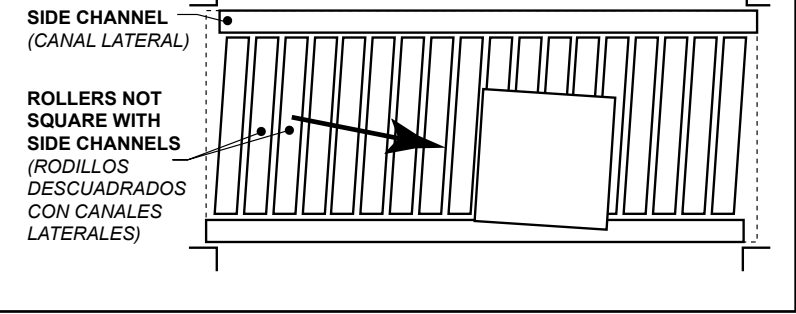

C) Before restarting a conveyor which has been stopped because of an emergency, an inspection of the conveyor shall be made and the cause of the stoppage determined. The starting device shall be locked out before any attempt is made to remove the cause of stoppage, unless operation is necessary to determine the cause or to safely remove the stoppage.

Refer to ANSI Z244.1-1982, American National Standard for Personnel Protection – Lockout/Tagout of Energy Sources – Minimum Safety Requirements and OSHA Standard Number 29 CFR 1910.147 "The Control of Hazardous Energy (Lockout/Tagout)."

## OPERATION

### • Conveyor Start-Up

Before conveyor is turned on, check for foreign objects that may have been left inside conveyor during installation. These objects could cause serious damage during start-up.

After conveyor has been turned on and is operating, check motors, reducers, and moving parts to make sure they are working freely.

**CAUTION!** Because of the many moving parts on the conveyor, all personnel in the area of the conveyor need to be warned that the conveyor is about to be started.

## MAINTENANCE

### • Lubrication

The drive chain is pre-lubricated from the manufacturer by a hot dipping process that ensures total lubrication of all components. However, continued proper lubrication will greatly extend the useful life of every drive chain.

Ambient Temperature Degrees F	SAE	ISO
20-40	20	46 or 68
40-100	30	100
100-120	40	150

Drive Chain lubrication serves several purposes including:

- Protecting against wear of the pin-bushing joint
- Lubricating chain-sprocket contact surfaces
- Preventing rust or corrosion

For normal operating environments, lubricate every 2080 hours of operation or every 6 months, whichever comes first. Lubricate with a good grade of petroleum or synthetic oil (i.e., Shell Rotella or Mobil 1). For best results, always use a brush to generously lubricate the chain. The proper viscosity of lubricant greatly affects its ability to flow into the internal areas of the chain. Refer to the table below for the proper viscosity of lubricant for your application.

The drive chain's lubrication requirement is greatly affected by the operating conditions. For harsh conditions such as damp environments, dusty environments, excessive speeds, or elevated temperatures, it is best to lubricate more frequently. It may be best, under these conditions, to develop a custom lubrication schedule for your specific application. A custom lubrication schedule may be developed by inspecting the drive chain on regular time intervals for sufficient lubrication. Once the time interval is determined at which the chain is not sufficiently lubricated, lubricate it and schedule the future lubrication intervals accordingly.

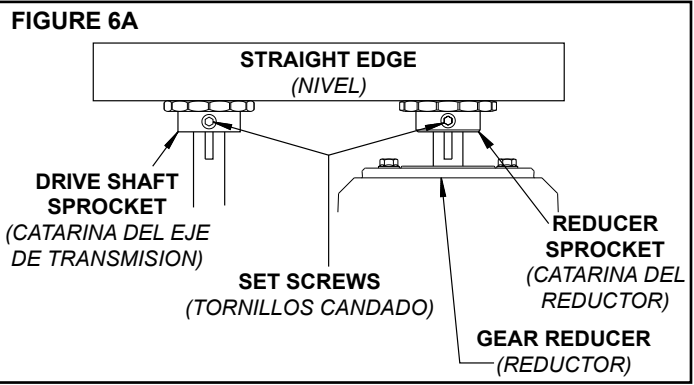

## • Drive Chain Alignment and Tension

The drive chain and sprockets should be checked periodically for proper tension and alignment. Improper adjustment will cause extensive wear to the drive components.

### TO MAKE ADJUSTMENTS

1. Remove chain guard.
2. Check sprocket alignment by placing a straight edge across the face of both sprockets. (Figure 6A.) Loosen set screws and adjust reducer sprocket as needed. Re-tighten set screws.
3. To adjust line shaft drive sprocket, loosen smaller nut (inner ring) of keyless bushing with a 1-3/4 in. open end wrench, while backing up with a 1-3/4 in. open end wrench on flats of bushing body (outer ring), which stays stationary. Move to desired location along the shaft, keeping sprocket face flush against shoulder of hex flats. Make sure shaft location is free from oil, grease, and dirt. Do not lubricate bushing or shaft. Note that as the inner ring nut is fully tightened, the assembly will move approximately 1/16 in. axially along shaft, away from the nut side. Re-check sprocket alignment, loosen and re-adjust if necessary.
4. To adjust chain tension, loosen bolts that fasten motor base to support channel. Tighten take-up bolts until desired chain tension is reached (Figure 6B & 6C.) Make sure both sides are adjusted the same amount to prevent mis-alignment of sprockets. Re-tighten mounting bolts.
5. Lubricate chain per lubrication instructions.
6. Replace chain guard so that it does not interfere with drive.

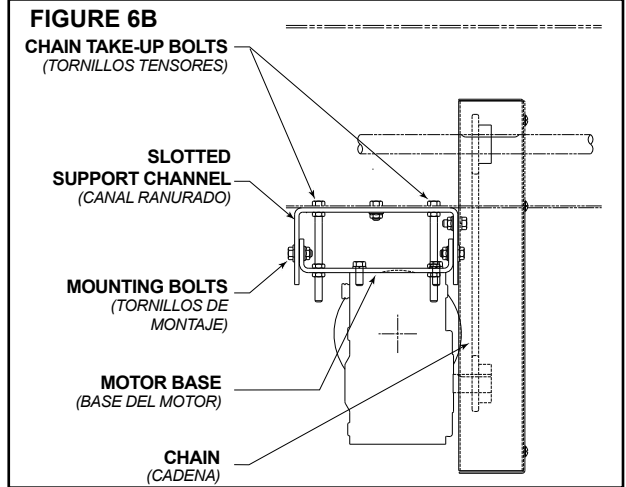

**CAUTION!** Never remove chain guards while the conveyor is running. Always replace guards after adjustments are made.

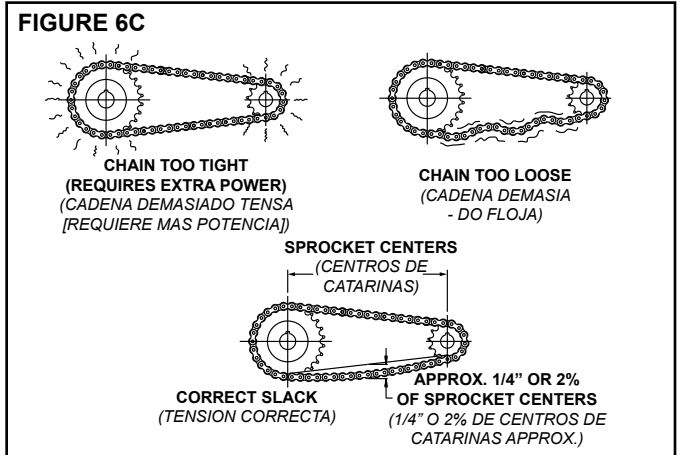

## • Trouble Shooting

TROUBLE SHOOTING DRIVES		
TROUBLE	CAUSE	SOLUTION
Conveyor will not start or motor quits frequently.	1) Motor is overloaded or drawing too much current. 2) Motor is drawing too much current.	1) Check for overloading of conveyor. 2) Check heater or circuit breaker and change if necessary.
Drive chain and sprockets wear excessively.	1) Sprockets are out of alignment. 2) Loose chain.	1) Align sprockets. See "Drive Chain Alignment and Tension" in this manual. 2) Tighten chain.
Loud popping or grinding noise.	1) Defective bearing. 2) Loose set screw in bearing. 3) Loose drive chain.	1) Replace bearing. 2) Tighten set screw. 3) Tighten chain.
Motor or reducer overheating.	1) Conveyor is overloaded. 2) Low voltage to motor. 3) Low lubricant level in reducer.	1) Check capacity of conveyor and reduce load to recommended level. 2) Have electrician check and correct as necessary. 3) Relubricate per manufacturer's recommendations. For HYTROL reducer, refer to Reducer Bulletin.
Tread Roller not turning under loaded conditions.	1) Oil on line shaft. 2) Unit overloaded. 3) Package flow obstructed by guard rail or other object. 4) Defective bearing in roller. 5) Broken drive band.	1) Clean the line shaft with K-2R spot remover or equivalent. 2) Check capacity of conveyor and reduce load to recommended level. 3) Clear obstruction. 4) Replace roller assembly. 5) Replace band.

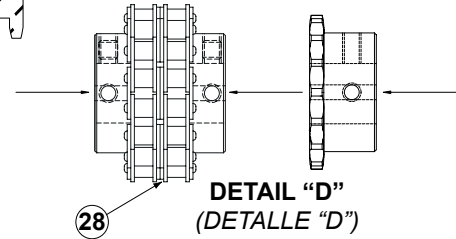
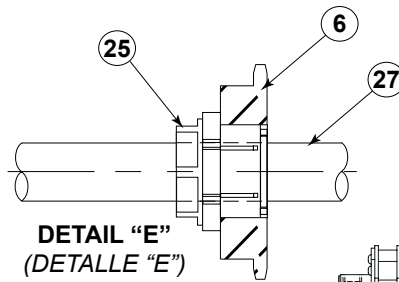
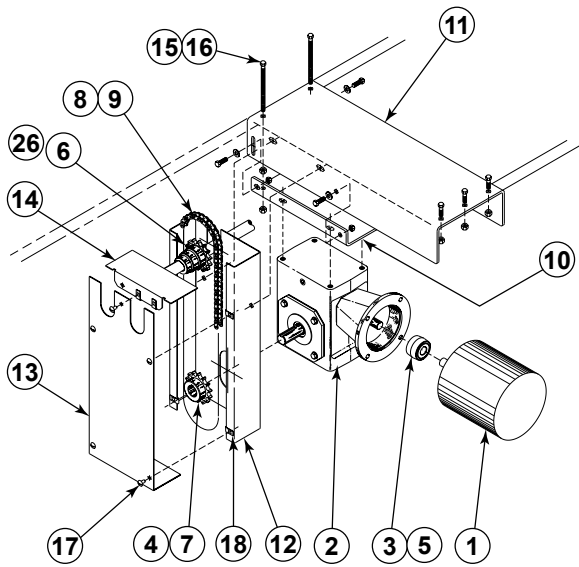
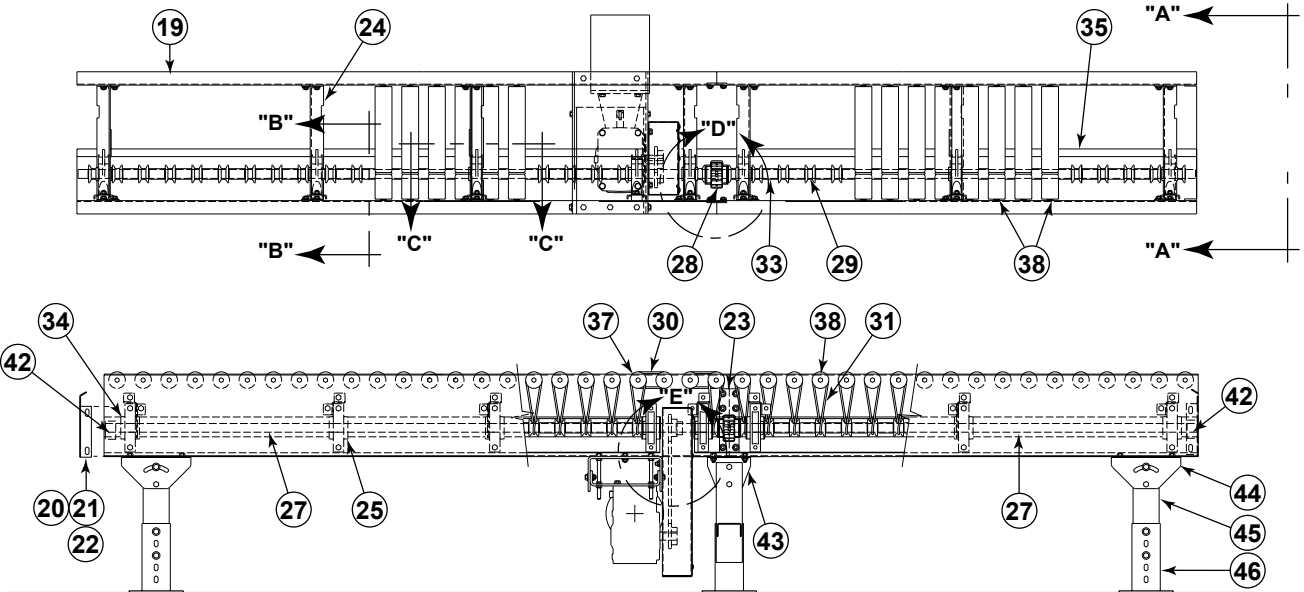

**DRIVE ASSEMBLY**  
*(ENSAMBLE MOTRIZ)*

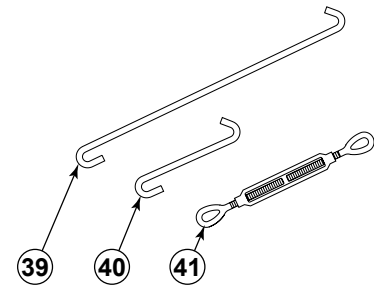
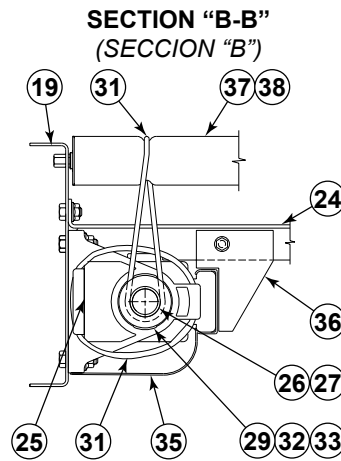
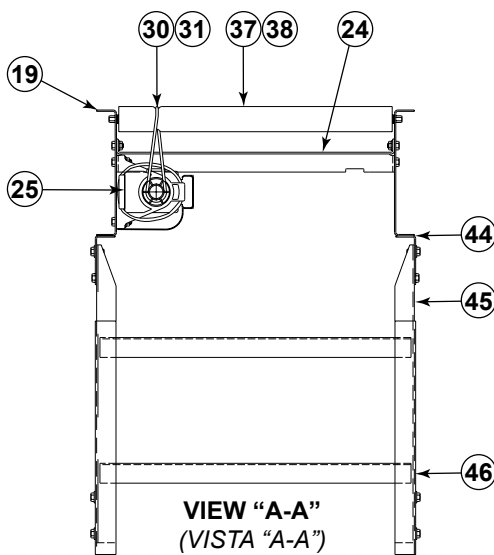

**SECTION 'C-C'**  
*(SECCION 'C')*

## • Model 190-NSP Parts List

## Lista de Partes del Modelo 190-NSP

Ref. No.	Part No.	Description
1	—	Motor, C-Face
—	030.7134	1/2 HP - 23/0460 VAC, 3 PH, 60 Hz, TEFC
—	030.7324	1 HP - 23/0460 VAC, 3 PH, 60 Hz, TEFC
—	030.7534	2 HP - 23/0460 VAC, 3 PH, 60 Hz, TEFC
2	—	Speed Reducer
—	R-00153-10R	4AC - RH - 10:1 Ratio
—	R-00153-10L	4AC - LH - 10:1 Ratio
—	R-00164-10R	5AC - RH - 10:1 Ratio
—	R-00164-10L	4AC - LH - 10:1 Ratio
3	—	Coupling Kit - Motor to Reducer
—	B-09179-B	1/2 - 1 HP
—	B-09179-C	1 1/2 - 2 HP
4	—	Sprocket - Reducer
—	028.120	50B17 x 1 in. Bore (4AC Reducer)
—	028.132	50B17 x 1 1/4 in. Bore (5AC Reducer)
5	090.202	Shaft Key - 3/16 in. Sq. x 1 in. Long
6	028.05018	Sprocket - Drive Shaft, 50B18 x 1 3/4 in. Bore
7	090.203	Shaft Key - 1/4 in. Sq. x 1 in. Long
8	029.101	#50 Riveted Roller Chain
9	029.201	Connector Link - #50 Roller Chain
10	B-24594	Motor Base Channel
11	B-24595	Support Channel (Specify BR)
12	B-24227	Chain Guard Back
13	B-24229	Chain Guard Front
14	B-24230	Chain Guard Top
15	040.313	Take-up Bolt - 3/8-16 x 5 in. Long
16	041.300	Hex Jam Nut - Heavy - 3/8-16
17	042.300	Truss Head Screw - 1/4-20 x 1/2 in. Long
18	049.310	U-Type Nut - 1/4-20
19	—	Frame Channel - 3 in. Roller Centers
—	B-24247	2 ft Long
—	B-24246	2 ft 6 in Long
—	B-24245	3 ft Long
—	B-24244	3 ft 6 in Long
—	B-24243	4 ft Long
—	B-24242	4 ft 6 in Long
—	B-24241	5 ft Long
—	B-24240	5 ft 6 in Long
—	B-24239	6 ft Long
—	B-24238	6 ft 6 in Long
—	B-24237	7 ft Long
—	B-24236	7 ft 6 in Long
—	B-24235	8 ft Long
—	B-24234	8 ft 6 Long
—	B-24233	9 ft Long
—	B-24232	9 ft 6 in Long
—	B-24231	10 ft long

Ref. No.	Part No.	Description
20	B-24269	End Guard (Specify BR)
21	040.302	Hex HD Cap Screw 3/8-16 x 5/8 in Long
22	049.5285	Small Flange Locknut 3/8-16 in x 5/8 in Long
23	B-24268	Splice Plate
24	B-24248	Bed Spacer Angle (Specify BR)
25	010.30116	Bearing - Glass Reinforced Nylon Housed
26	099.1289	Keyless Bushing 1 in. Inner Diameter
27	B-09029	Drive Shaft (Specify Length)
28	052.155	Chain Coupling (Includes Sprockets and Chain)
29	094.410	Drive Spool
30	090.255	O-Ring - 1/8 in. (Slave)
31	090.256	O-Ring - 3/16 in. (Drive)
32	094.42510	Spool Spacer - 5/8 in Long
33	094.42527	Spool Spacer - 1-11/16 in Long
34	049.220	Nylon Washer - 1/8 in. Thick
35	094.424	Drive Shaft Guard (Specify Length)
36	B-24549	Drive Shaft Guard Retainer Bracket
37	B-21914	1.9 in Dia. Roller - Two Grooves (Specify BR)
38	B-06535	1.9 in Dia. Roller - One Groove (Specify BR)
39	044.120	Cross Brace Rod 70 in Long
40	044.121	Cross Brace Rod 6 in Long
41	049.308	Turnbuckle
42	098.184	Lock Collar
43	—	Narrow MS Pivot Plate - 1-1/2 in Flange (Only)
—	B-04103	4 in. High
—	B-21027	1-9/16 in High
44	—	MS Pivot Plate - 1-1/2 in Flange
—	B-00913	3-11/16 in High
—	B-02112	1-9/16 in High
45	—	Floor Support Frame
—	B-00914	6 in High (Specify OAW)
—	B-12777	7 in High (Specify OAW)
—	B-12778	8 in High (Specify OAW)
—	B-00915	9 in High (Specify OAW)
—	B-00916	11 1/2 in High (Specify OAW)
—	B-00917	14 1/2 in High (Specify OAW)
—	B-02098	18 1/2 in High (Specify OAW)
—	B-00919	22 1/2 in High (Specify OAW)
—	B-00921	32 1/2 in High (Specify OAW)
—	B-00923	44 1/2 in High (Specify OAW)
—	B-00925	56 1/2 in High (Specify OAW)
—	B-02107	68 1/2 in High (Specify OAW)
—	B-02109	78 1/2 in High (Specify OAW)
—	B-02111	90 1/2 in High (Specify OAW)
46	B-00911	Adjustable Foot Assembly (Specify Length)



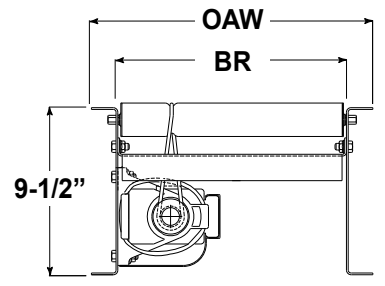
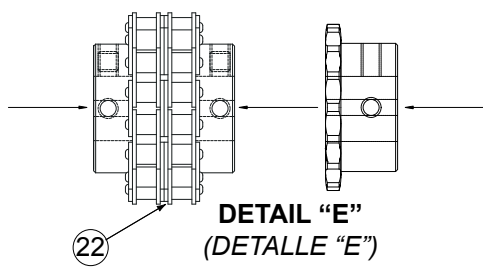
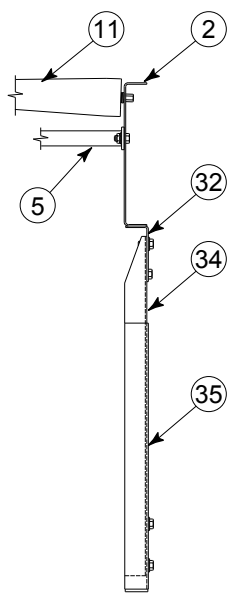
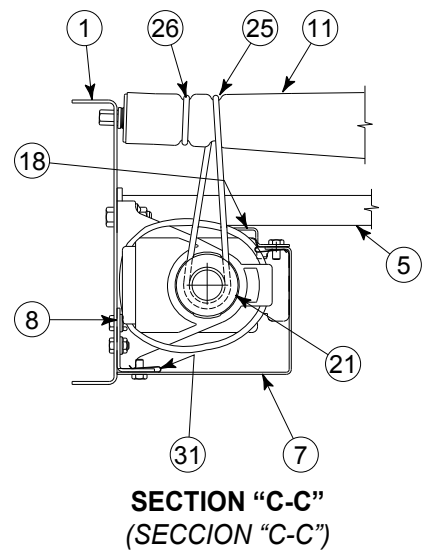
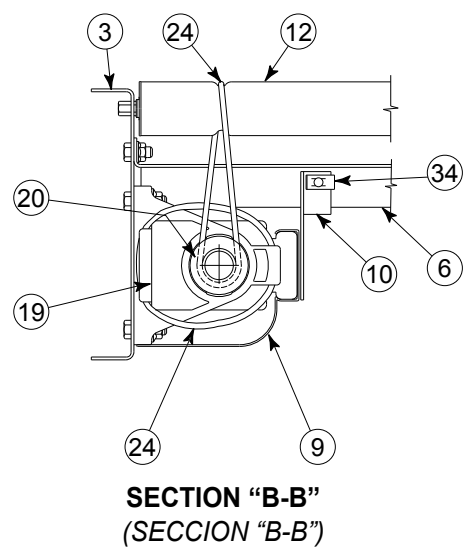
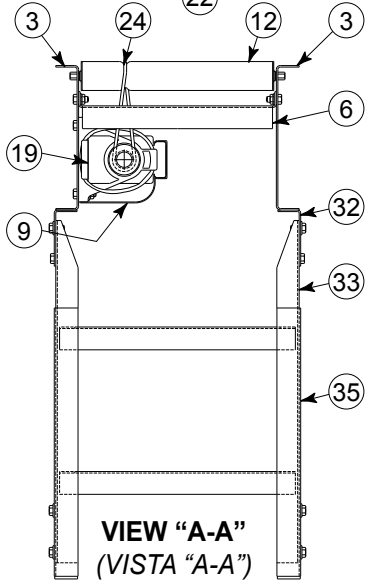
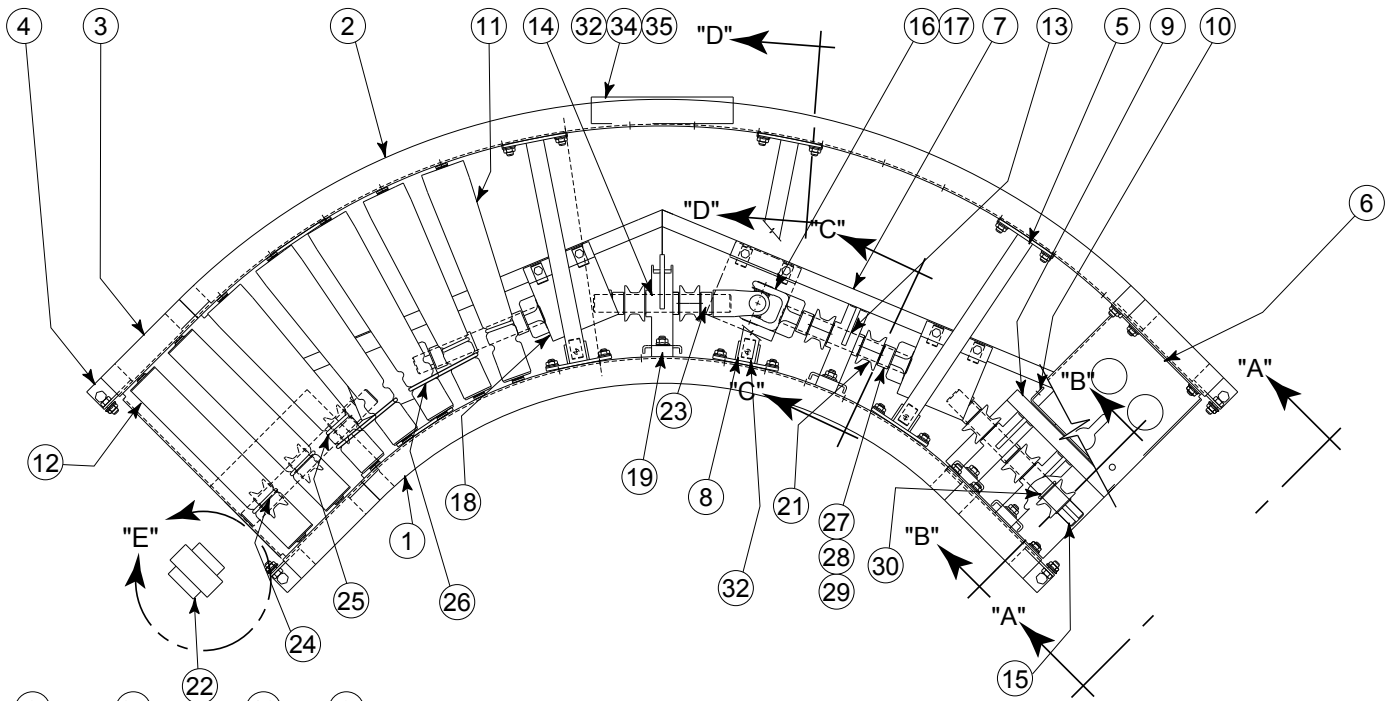

## • Model 190-NSPC 90° Parts List

### *Lista de Partes del Modelo 190-NSPC 90°*

Ref. No.	Part No.	Description
1	—	Inside Channel
—	B-24439	13 in BR
—	B-24441	15 in thru 27 in BR
—	B-24443	31 in thru 39 in BR
2	—	Outside Channel
—	B-24440	13 in BR
—	B-24442	15 in thru 27 in BR (Specify)
—	B-24444	31 in thru 39 in BR (Specify)
3	B-24451	Tangent Channel
4	B-24456	Coupling Angle
5	B-24445	Bed Spacer Assembly - Curve (Specify BR)
6	B-24454	Bed Spacer Channel - Tangent (Specify BR)
7	—	Drive Shaft Guard - Curve
—	B-24446	13 in BR
—	B-24447	15 in thru 27 in BR
—	B-24448	31 in thru 39 in BR
8	B-24449	Shaft Guard Mounting Bracket
9	094.424	Drive Shaft Guard - Tangent (Specify Length)
10	B-25120-A	Shaft Guard Retainer Bracket
11	B-10361	1.9 in Tapered Roller - Two Grooves (Specify BR)
12	B-06535	1.9 in Dia Roller - One Groove (Specify BR)
13	—	Drive Shaft - Curve - Ends
—	B-17611-062	7-3/4 in Long (13 in BR)
—	B-17611-089	11-1/8 in Long (15 in thru 27 in BR)
—	B-17611-141	17-5/8 in Long (31 in thru 39 in BR)
14	—	Drive Shaft - Curve - Center
—	B-17611-062	7-3/4 in Long (13 in BR)
—	B-17611-089	11-1/8 in Long (15 in thru 27 in BR)
—	B-17611-135	16-7/8 in Long (31 in thru 39 in BR)
15	—	Drive Shaft - Tangent
—	B-24515-080	10 in Long (13 in BR)
—	B-24515-093	11-5/8 in Long (15 in thru 27 in BR)
—	B-24515-116	14-1/2 in Long (31 in thru 39 in BR)
16	092.155	Universal Joint
17	049.5025	Hex Bolt - 3/8-16 x 1-3/4 in Long (Hardened)
18	B-24450	Universal Joint Guard
19	010.30116	Bearing - Glass Reinforced Nylon Housed
20	094.410	Drive Spool
21	094.4101	Drive Spool - Positive Drive
22	052.155	Chain Coupling (Includes Sprockets and Chain)
23	090.203	Shaft Key - 1/4 in Sq. x 1 in Long
24	090.256	O-Ring - 3/16 in (Drive - Tangent)
25	090.2561	O-Ring - 3/16 in (Drive - Curve)
26	090.2551	O-Ring - 3/16 in (Slave - Curve)
27	094.42510	Spool Spacer - 5/8 in Long
28	094.42516	Spool Spacer - 1 in Long
29	094.42523	Spool Spacer - 1-7/16 in Long
30	049.220	Nylon Washer - 1/8 in Thick
31	049.310	U-Type Nut - 1/4-20
32	—	MS Pivot Plate - 1-1/2 in Flange
—	B-00913	3-11/16 in High
—	B-02112	1-9/16 in High
33	—	Floor Support Frame
—	B-00914	6 in High (Specify OAW)
—	B-12777	7 in High (Specify OAW)
—	B-12778	8 in High (Specify OAW)
—	B-00915	9 in High (Specify OAW)
—	B-00916	11 1/2 in High (Specify OAW)
—	B-00917	14 1/2 in High (Specify OAW)
—	B-02098	18 1/2 in High (Specify OAW)
—	B-00919	22 1/2 in High (Specify OAW)
—	B-00921	32 1/2 in High (Specify OAW)
—	B-00923	44 1/2 in High (Specify OAW)
—	B-00925	56 1/2 in High (Specify OAW)
—	B-02107	68 1/2 in High (Specify OAW)
—	B-02109	78 1/2 in High (Specify OAW)
—	B-02111	90 1/2 in High (Specify OAW)
34	B-00909	Center Support Leg (Specify Length)
35	B-00911	Adjustable Foot Assembly (Specify Length)

## • Model 190-NSPC 60° Parts List

### *Lista de Partes del Modelo 190-NSPC 60°*

Ref. No.	Part No.	Description
1	—	Inside Channel
—	B-25101	13 in BR
—	B-25103	15 in thru 27 in BR
—	B-25105	31 in thru 39 in BR
2	—	Outside Channel
—	B-25102	13 in BR
—	B-25104	15 in thru 27 in BR (Specify)
—	B-25106	31 in thru 39 in BR (Specify)
3	B-24451	Tangent Channel
4	B-24456	Coupling Angle
5	B-24445	Bed Spacer Assembly - Curve (Specify BR)
6	B-24454	Bed Spacer Channel - Tangent (Specify BR)
7	—	Drive Shaft Guard - Curve
—	B-24525	13 in BR
—	B-24526	15 in thru 27 in BR
—	B-24527	31 in thru 39 in BR
8	B-24449	Shaft Guard Mounting Bracket
9	B-24528	Shaft Guard Support Bracket
10	094.424	Drive Shaft Guard - Tangent (Specify Length)
11	B-25120-A	Shaft Guard Retainer Bracket
12	B-10361	1.9 in Tapered Roller - Two Grooves (Specify BR)
13	B-06535	1.9 in Dia Roller - One Groove (Specify BR)
14	—	Drive Shaft - Curve - Ends
—	B-17611-091	11-3/8 in Long (13 in BR)
—	B-17611-051	6-3/8 in Long (15 in thru 27 in BR)
—	B-17611-084	10-1/2 in Long (31 in thru 39 in BR)
15	—	Drive Shaft - Tangent
—	B-24515-095	11-7/8 in Long (13 in BR)
—	B-24515-074	9-1/4 in Long (15 in thru 27 in BR)
—	B-24515-091	11-3/8 in Long (31 in thru 39 in BR)
16	092.155	Universal Joint
17	049.5025	Hex Bolt - 3/8-16 x 1-3/4 in Long (Hardened)
18	B-24450	Universal Joint Guard
19	010.30116	Bearing - Glass Reinforced Nylon Housed
20	094.410	Drive Spool
21	094.4101	Drive Spool - Positive Drive
22	052.155	Chain Coupling (Includes Sprockets and Chain)
23	090.203	Shaft Key - 1/4 in Sq. x 1 in Long
24	090.256	O-Ring - 3/16 in (Drive - Tangent)
25	090.2561	O-Ring - 3/16 in (Drive - Curve)
26	090.2551	O-Ring - 3/16 in (Slave - Curve)
27	094.42510	Spool Spacer - 5/8 in Long
28	094.42523	Spool Spacer - 1-7/16 in Long
29	049.220	Nylon Washer - 1/8 in Thick
30	049.310	U-Type Nut - 1/4-20
31	—	MS Pivot Plate - 1-1/2 in Flange
—	B-00913	3-11/16 in High
—	B-02112	1-9/16 in High
32	—	Floor Support Frame
—	B-00914	6 in High (Specify OAW)
—	B-12777	7 in High (Specify OAW)
—	B-12778	8 in High (Specify OAW)
—	B-00915	9 in High (Specify OAW)
—	B-00916	11 1/2 in High (Specify OAW)
—	B-00917	14 1/2 in High (Specify OAW)
—	B-02098	18 1/2 in High (Specify OAW)
—	B-00919	22 1/2 in High (Specify OAW)
—	B-00921	32 1/2 in High (Specify OAW)
—	B-00923	44 1/2 in High (Specify OAW)
—	B-00925	56 1/2 in High (Specify OAW)
—	B-02107	68 1/2 in High (Specify OAW)
—	B-02109	78 1/2 in High (Specify OAW)
—	B-02111	90 1/2 in High (Specify OAW)
33	B-00909	Center Support Leg (Specify Length)
34	B-00911	Adjustable Foot Assembly (Specify Length)

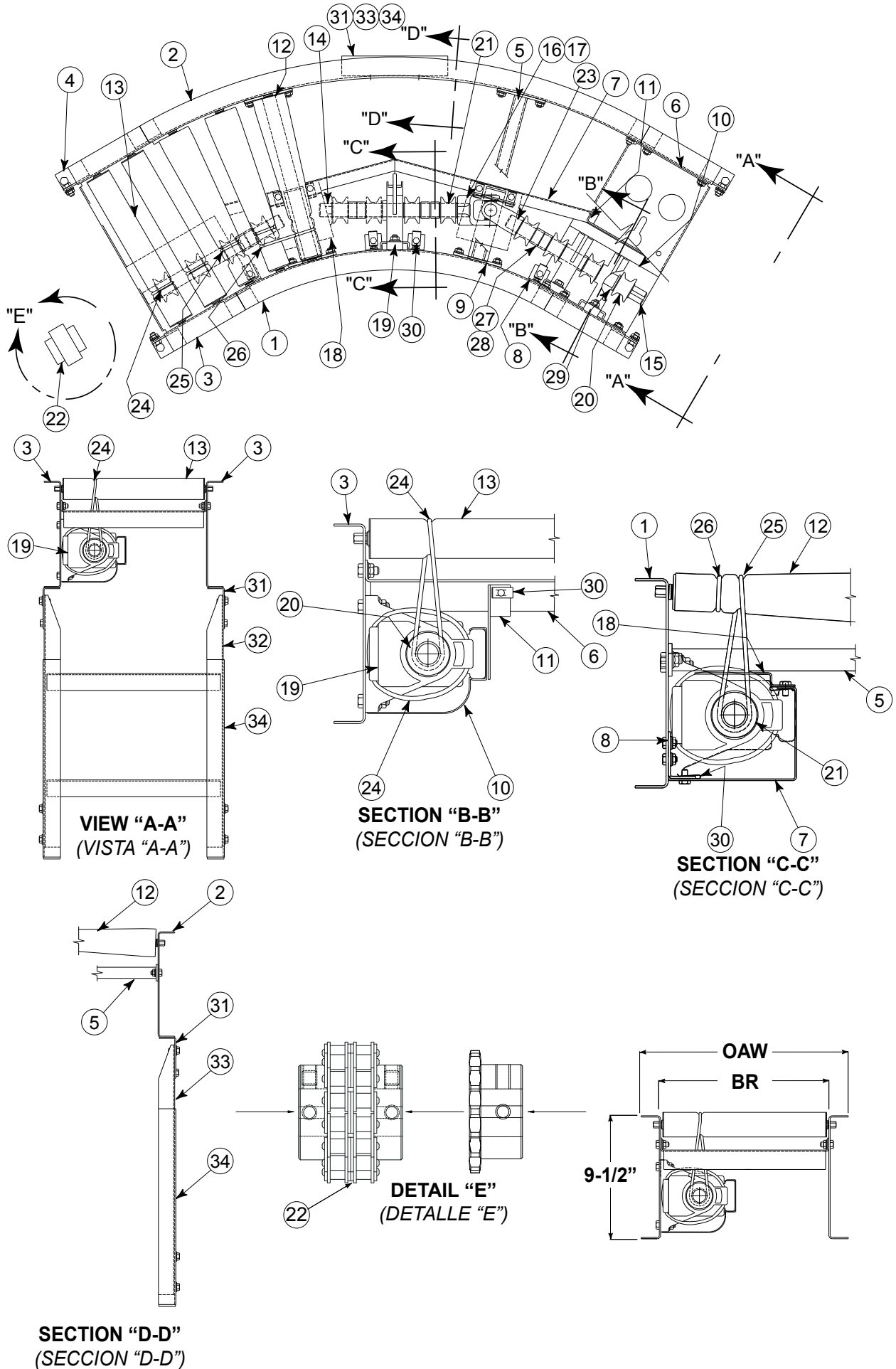

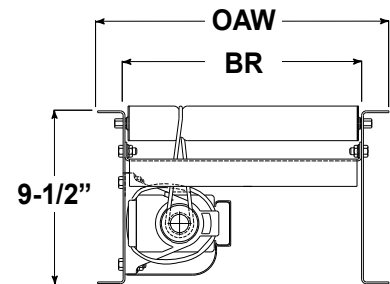
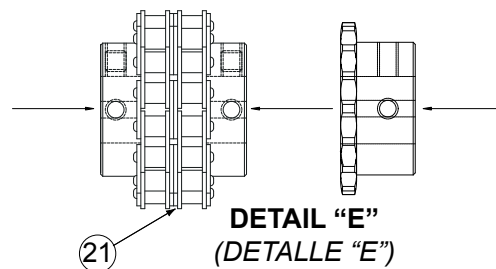
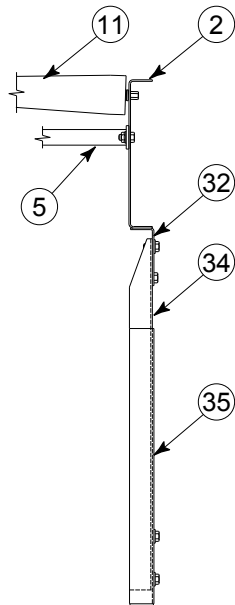
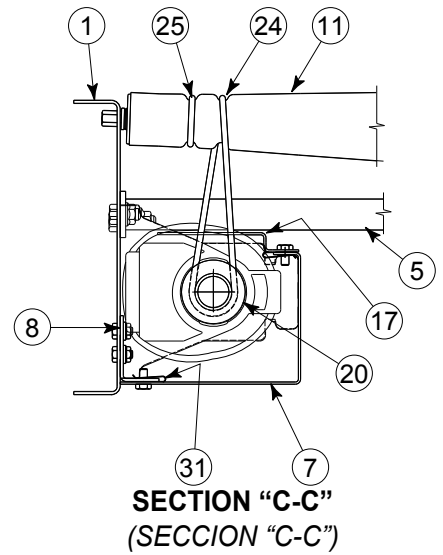
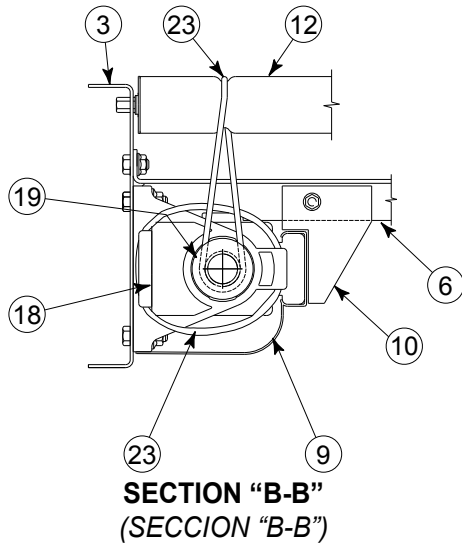
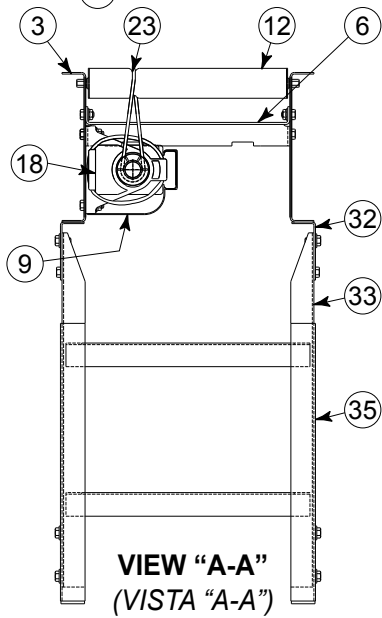
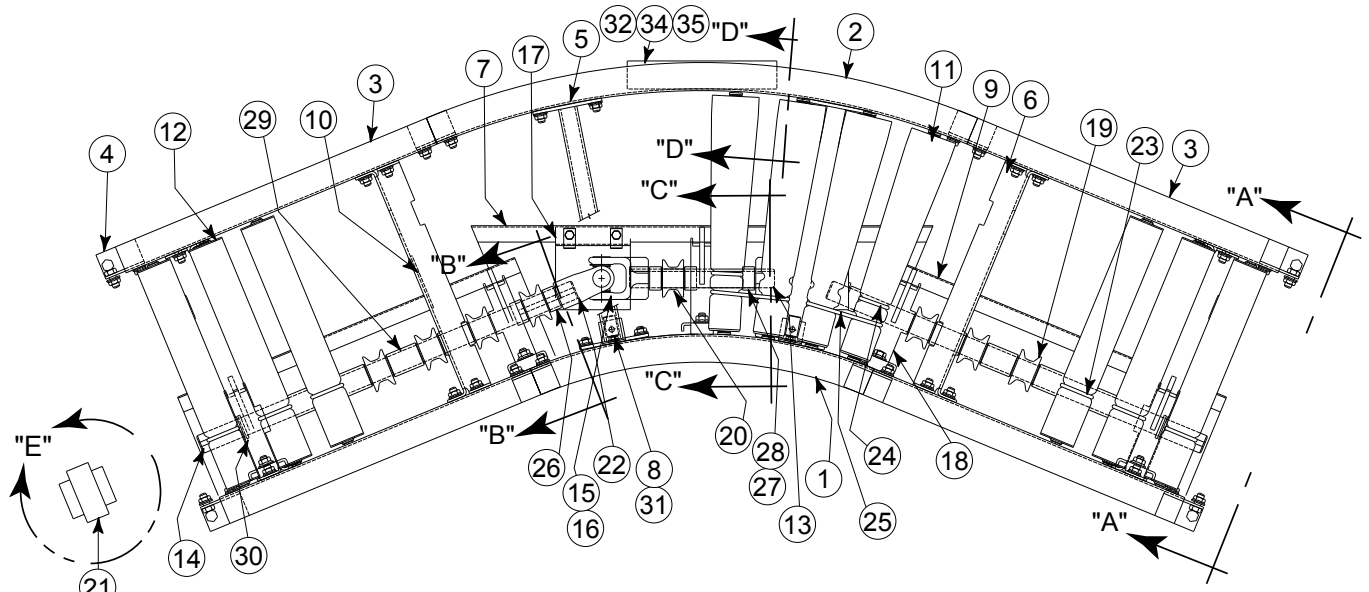

**SECTION "D-D"**  
(SECCION "D-D")

• **Model 190-NSPC 45° Parts List**

**Lista de Partes del Modelo 190-NSPC 45°**

Ref. No.	Part No.	Description
1	—	Inside Channel
—	B-24495	13 in BR
—	B-24497	15 in thru 27 in BR
—	B-24499	31 in thru 39 in BR
2	—	Outside Channel
—	B-24496	13 in BR
—	B-24498	15 in thru 27 in BR (Specify)
—	B-24444	31 in thru 39 in BR (Specify)
3	B-24453-018	Tangent Channel
4	B-24456	Coupling Angle
5	B-24445	Bed Spacer Assembly - Curve (Specify BR)
6	B-24248	Bed Spacer Angle - Tangent (Specify BR)
7	—	Drive Shaft Guard - Curve
—	B-24446	13 in BR
—	B-24447	15 in thru 27 in BR
—	B-24448	31 in thru 39 in BR
8	B-24449	Shaft Guard Mounting Bracket
9	094.424	Drive Shaft Guard - Tangent (Specify Length)
10	B-24549	Shaft Guard Retainer Bracket
11	B-10361	1.9 in Tapered Roller - Two Grooves (Specify BR)
12	B-06535	1.9 in Dia. Roller - One Groove (Specify BR)
13	—	Drive Shaft Curve
—	B-17611-062	7-3/4 in Long (13 in BR)
—	B-17611-089	11-1/8 in Long (15 in thru 27 in BR)
—	B-17611-141	17-5/8 in Long (31 in thru 39 in BR)
14	—	Drive Shaft - Tangent
—	B-24515-174	21-3/4 in Long (13 in BR)
—	B-24515-187	23-3/8 in Long (15 in thru 27 in BR)
—	B-24515-210	26-1/4 in Long (31 in thru 39 in BR)
15	092.155	Universal Joint Guard
16	049.5025	Hex Bolt - 3/8-16 x 1-3/4 in Long (Hardened)
17	B-24450	Universal Joint Guard
18	010.30116	Bearing - Glass Reinforced Nylon Housed
19	094.410	Drive Spool
20	094.4101	Drive Spool - Positive Drive
21	052.155	Chain Coupling (Includes Sprockets and Chain)
22	090.203	Shaft Key - 1/4 Sq. in x 1 in Long
23	090.256	O-Ring - 3/16 in (Drive - Tangent)
24	090.2561	O-Ring - 3/16 in (Drive - Curve)
25	090.2551	O-Ring - 3/16 in (Slave - Curve)
26	094.42510	Spool Spacer - 5/8 in Long
27	094.42516	Spool Spacer - 1 in Long
28	094.42523	Spool Spacer - 1-7/16 in Long
29	094.42527	Spool Spacer - 1-11/16 in Long
30	049.220	Nylon Washer - 1/8 in Thick
31	049.310	U-Type Nut - 1/4-20
32	—	MS Pivot Plate - 1-1/2 in Flange
—	B-00913	3-11/16 in High
—	B02112	1-9/16 in High
33	—	Floor Support Frame
—	B-00914	6 in High (Specify OAW)
—	B-12777	7 in High (Specify OAW)
—	B-12778	8 in High (Specify OAW)
—	B-00915	9 in High (Specify OAW)
—	B-00916	11 1/2 in High (Specify OAW)
—	B-00917	14 1/2 in High (Specify OAW)
—	B-02098	18 1/2 in High (Specify OAW)
—	B-00919	22 1/2 in High (Specify OAW)
—	B-00921	32 1/2 in High (Specify OAW)
—	B-00923	44 1/2 in High (Specify OAW)
—	B-00925	56 1/2 in High (Specify OAW)
—	B-02107	68 1/2 in High (Specify OAW)
—	B-02109	78 1/2 in High (Specify OAW)
—	B-02111	90 1/2 in High (Specify OAW)
34	B-00909	Center Support Leg (Specify Length)
35	B-00911	Adjustable Foot Assembly (Specify Length)

• **Model 190-NSPC 30° Parts List**

**Lista de Partes del Modelo 190-NSPC 30°**

Ref. No.	Part No.	Description
1	—	Inside Channel
—	B-24519	13 in BR
—	B-24521	15 in thru 27 in BR
—	B-24523	31 in thru 39 in BR
2	—	Outside Channel
—	B-24520	12 in BR
—	B-24522	15 in thru 27 in BR (Specify)
—	B-24524	31 in thru 39 in BR (Specify)
3	B-24453-018	Tangent Channel
4	B-24456	Coupling Angle
5	B-24445	Bed Spacer Assembly - Curve (Specify BR)
6	B-24248	Bed Spacer Angle (Specify BR)
7	—	Drive Shaft Guard - Curve
—	B-24525	13 in BR
—	B-24526	15 in 27 in BR
—	B-24527	31 in 39 in BR
8	B-24449	Shaft Guard Mounting Bracket
9	B-24528	Shaft Guard Support Bracket
10	094.424	Drive Shaft Guard - Tangent (Specify Length)
11	B-24549	Shaft Guard Retainer Bracket
12	B-10361	1.9 in Tapered Roller - Two Grooves (Specify BR)
13	B-06535	1.9 in Tapered Roller - One Groove (Specify BR)
14	—	Drive Shaft - Curve
—	Not Req'd	(13 in BR)
—	B-17611-051	6-3/8 in Long (15 in thru 27 in BR)
—	B-17611-084	10-1/2 in Long (31 in thru 39 in BR)
15	—	Drive Shaft - Tangent
—	B-24515-189	23-5/8 in Long (13 in BR)
—	B-24515-168	21 in Long (15 in thru 27 in BR)
—	B-24515-185	23-1/8 in Long (31 in thru 39 in BR)
16	092.155	Universal Joint
17	049.5025	Hex Bolt - 3/8-16 x 1-3/4 in Long (Hardened)
18	B-24450	Universal Joint Guard
19	010.30116	Bearing - Glass Reinforced Nylon Housed
20	094.410	Drive Spool
21	094.4101	Drive Spool - Positive Drive
22	052.155	Chain Coupling (Includes Sprockets and Chain)
23	090.203	Shaft Key - 1/4 in Sq. x 1 in Long
24	090.256	O-Ring - 3/16 in (Drive - Tangent)
25	090.2561	O-Ring - 3/16 in (Drive - Curve)
26	090.2551	O-Ring - 3/16 in (Slave - Curve)
27	094.42510	Spool Spacer - 5/8 in Long
28	094.42523	Spool Spacer - 1-7/16 in Long
29	094.42527	Spool Spacer - 1-11/16 in Long
30	049.220	Nylon Washer - 1/8 in Thick
31	049.310	U-Type Nut - 1/4-20
32	—	MS Pivot Plate - 1-1/2 in Flange
—	B-00913	3-11/16 in High
—	B-02112	1-9/16 in High
33	—	Floor Support Frame
—	B-00914	6 in High (Specify OAW)
—	B-12777	7 in High (Specify OAW)
—	B-12778	8 in High (Specify OAW)
—	B-00915	9 in High (Specify OAW)
—	B-00916	11 1/2 in High (Specify OAW)
—	B-00917	14 1/2 in High (Specify OAW)
—	B-02098	18 1/2 in High (Specify OAW)
—	B-00919	22 1/2 in High (Specify OAW)
—	B-00921	32 1/2 in High (Specify OAW)
—	B-00923	44 1/2 in High (Specify OAW)
—	B-00925	56 1/2 in High (Specify OAW)
—	B-02107	68 1/2 in High (Specify OAW)
—	B-02109	78 1/2 in High (Specify OAW)
—	B-02111	90 1/2 in High (Specify OAW)
34	B-00909	Center Support Leg (Specify Length)
35	B-00911	Adjustable Foot Assembly (Specify Length)

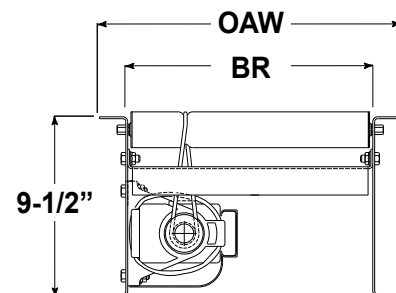
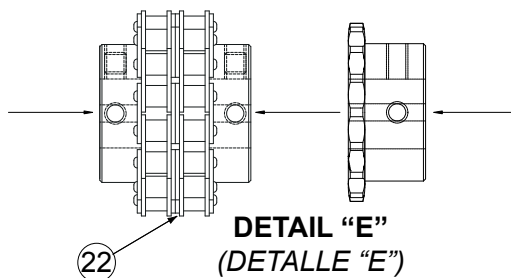
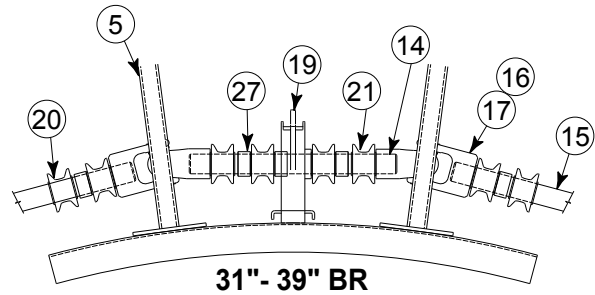
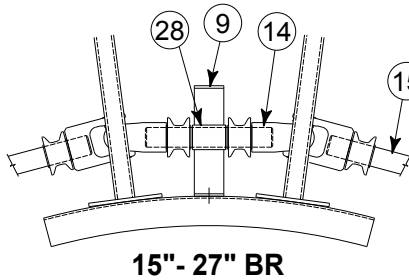
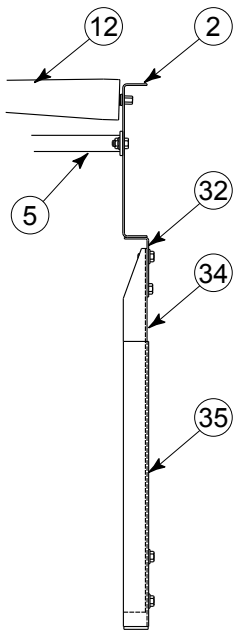
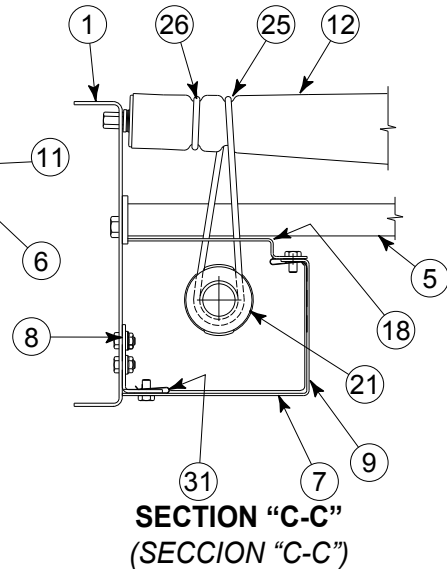
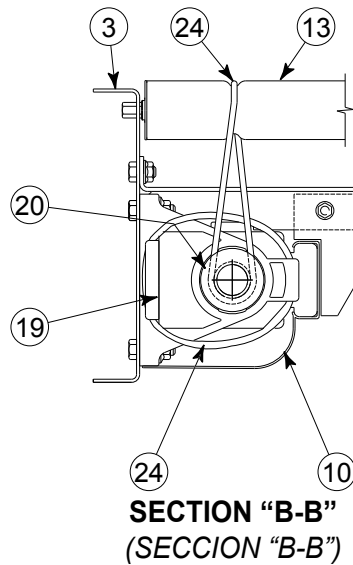
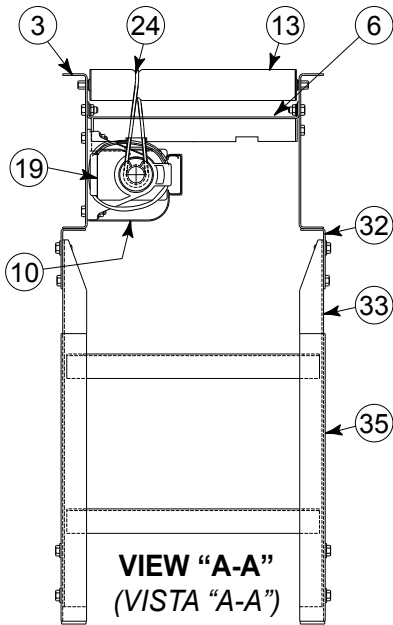
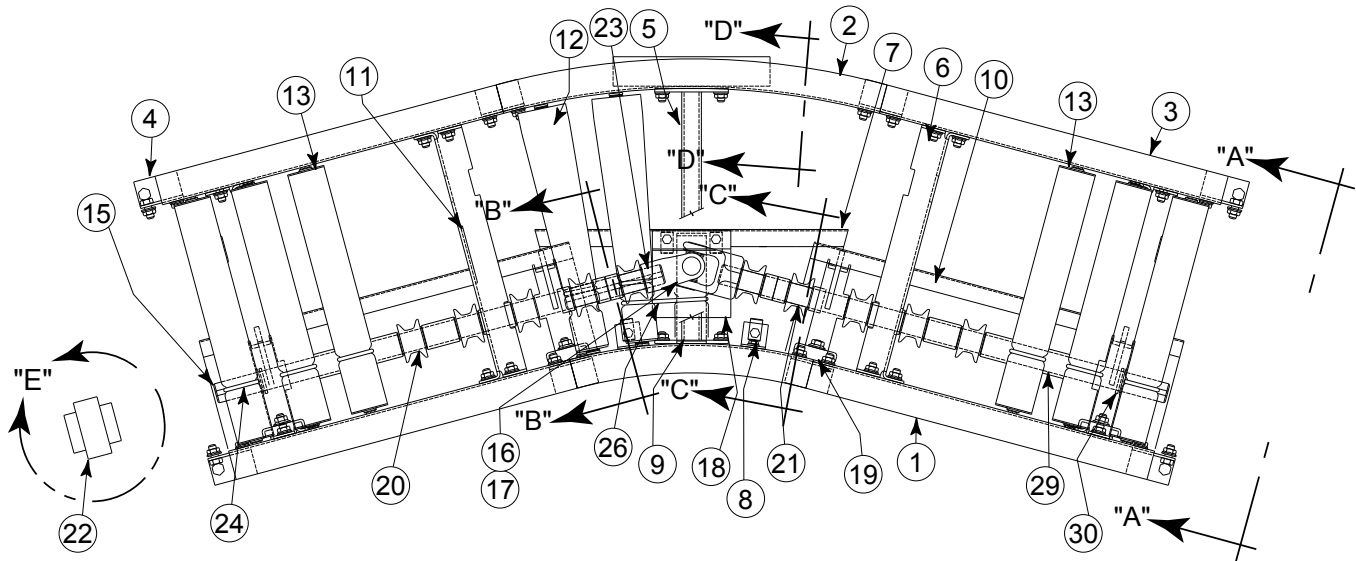

## • Model 190-NSPS 45° Parts List

Ref. No.	Part No.	Description
1	—	Inside Channel
—	B-24495	13 in BR
—	B-24497	15 in thru 27 in BR
—	B-24499	31 in thru 39 in BR
2	—	Outside Channel
—	B-24496	13 in BR
—	B-24498	15 in thru 27 in BR (Specify)
—	B-24444	31 in thru 39 in BR (Specify)
3	B-24453-018	Tangent Channel
4	B-25094	Short Spur Channel (Specify BR and RH or LH)
5	B-25095	Long Spur Channel (Specify Length and RH or LH)
6	—	Coupling - Short Spur Channel
—	B-24369-R	RH Spur
—	B-24369-L	LH Spur
7	—	Coupling - Long Spur Channel
—	B-24356-R	RH Spur
—	B-24356-L	LH Spur
8	B-24367	Spur Plate (Specify BR and RH or LH)
9	B-04415	Spur Roller Bracket
10	G-00571-012	K-Bracket - 9-1/2 in Channel
11	B-24456	Coupling Angle
12	B-24445	Bed Spacer Assembly - Curve (Specify BR)
13	B-24248	Bed Spacer Angle - Tangent and Spur (Specify BR)
14	—	Drive Shaft Guard - Curve
—	B-24446	13 in BR
—	B-24447	15 in thru 27 in BR
—	B-24448	31 in thru 39 in BR
15	B-24449	Shaft Guard Mounting Bracket
16	094.424	Drive Shaft Guard - Tangent/Spur (Specify Length)
17	B-24549	Shaft Guard Retainer Bracket
18	B-10361	1.9 in Tapered Roller - Two Grooves (Specify BR)
19	B-06535	1.9 in Dia Roller - One Groove (Specify BR)
20	B-01235-024	1.9 in Dia Roller - One Groove 3 in Between Brackets
21	B-01234-048	1.9 in Dia Roller - Two Grooves 6 in Between Brackets
22	—	1.9 in Dia Roller - One Groove
—	B-06535-072	9 in Between Rails
—	B-06535-096	12 in Between Rails
—	B-06535-120	15 in Between Rails
—	B-06535-144	18 in Between Rails
—	B-06535-168	21 in Between Rails
—	B-06535-192	24 in Between Rails
—	B-06535-216	27 in Between Rails
—	B-06535-240	30 in Between Rails
—	B-06535-264	33 in Between Rails
—	B-06535-288	36 in Between Rails
23	—	Drive Shaft - Curve
—	B-17611-062	7-3/4 in Long (13 in BR)
—	B-17611-089	11-1/8 in Long (15 in thru 27 in BR)
—	B-17611-141	17-5/8 in Long (31 in thru 39 in BR)
24	—	Drive Shaft - Tangent
—	B-24515-174	21-3/4 in Long (13 in BR)
—	B-24515-187	23-3/8 in Long (15 in thru 27 in BR)
—	B-24515-210	26-1/4 in Long (31 in thru 39 in BR)
25	—	Drive Shaft - Spur
—	B-17611-162	20-1/4 in Long (13 in BR)
—	B-17611-296	37 in Long (15 in thru 27 in BR)
—	B-17611-415	51-7/8 in Long (31 in thru 39 in BR)
26	092.155	Universal Joint
27	049.5025	Hex Bolt - 3/8-16 x 1-3/4 in Long (Hardened)
28	B-24450	Universal Joint Guard
29	010.30116	Bearing - Glass Reinforced Nylon Housed
30	094.410	Drive Spool
31	094.4101	Drive Spool - Positive Drive
32	052.155	Chain Coupling (Includes Sprockets and Chain)
33	090.203	Shaft Key - 1/4 in Sq. x 1 in Long
34	090.256	O-Ring - 3/16 in (Drive - Tangent)

## Lista de Partes del Modelo 190-NSPS 45°

Ref. No.	Part No.	Description
35	090.255	O-Ring - 3/16 in (Slave - Spur)
36	090.2561	O-Ring - 3/16 in (Drive - Curve)
37	090.2551	O-Ring - 3/16 in (Slave - Curve)
38	094.42510	Spool Spacer - 5/8 in Long
39	094.42516	Spool Spacer - 1 in Long
40	094.42523	Spool Spacer - 1-7/16 in Long
41	094.42527	Spool Spacer 1-11/16 in Long
42	049.220	Nylong Washer - 1/8 in Thick
43	049.440	Socket Button Head Screw - 3/8-16 x 3/4 in Long
44	049.310	U-Type Nut - 1/4-20
45	098.184	Locking Collar - 1 in ID x 1-9/16 in OD x 5/8 in Long
46	—	MS Pivot Plate - 1-1/2 in Flange
—	B-00913	3-11/16 in High
—	B-002112	1-9/16 in High
47	—	Floor Support Frame
—	B-00914	6 in High (Specify OAW)
—	B-12777	7 in High (Specify OAW)
—	B-12778	8 in High (Specify OAW)
—	B-00915	9 in High (Specify OAW)
—	B-00916	11 1/2 in High (Specify OAW)
—	B-00917	14 1/2 in High (Specify OAW)
—	B-02098	18 1/2 in High (Specify OAW)
—	B-00919	22 1/2 in High (Specify OAW)
—	B-00921	32 1/2 in High (Specify OAW)
—	B-00923	44 1/2 in High (Specify OAW)
—	B-00925	56 1/2 in High (Specify OAW)
—	B-02107	68 1/2 in High (Specify OAW)
—	B-02109	78 1/2 in High (Specify OAW)
—	B-02111	90 1/2 in High (Specify OAW)
48	B-00909	Center Support Leg (Specify Length)
49	B-00911	Adjustable Foot Assembly (Specify Length)

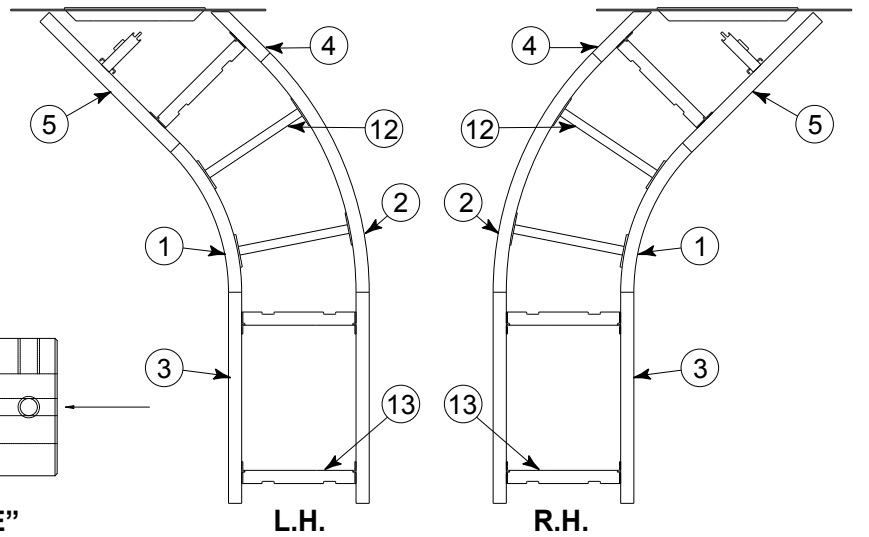
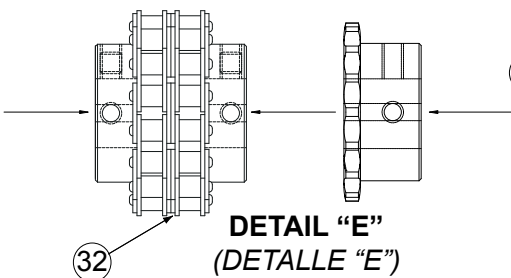
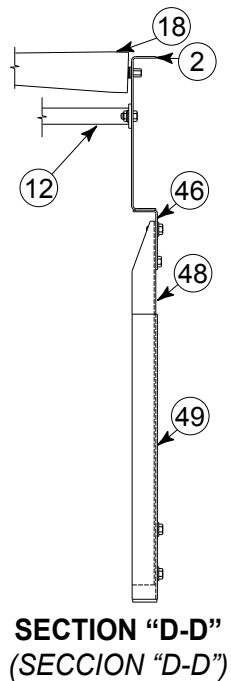
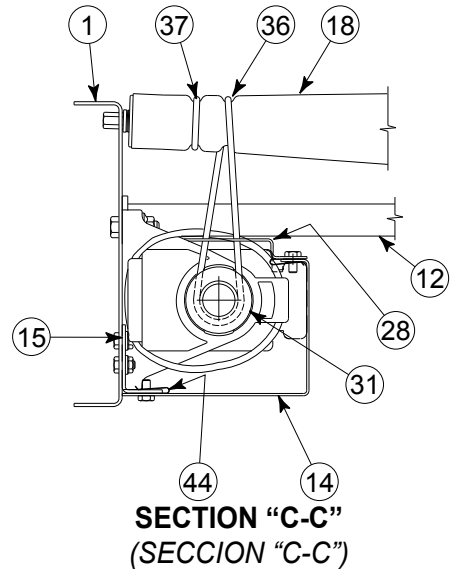
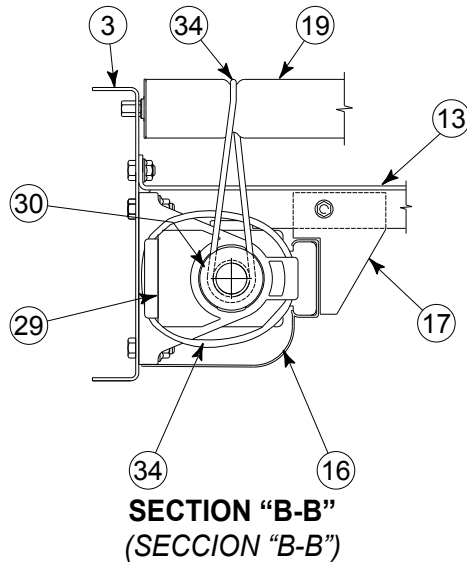
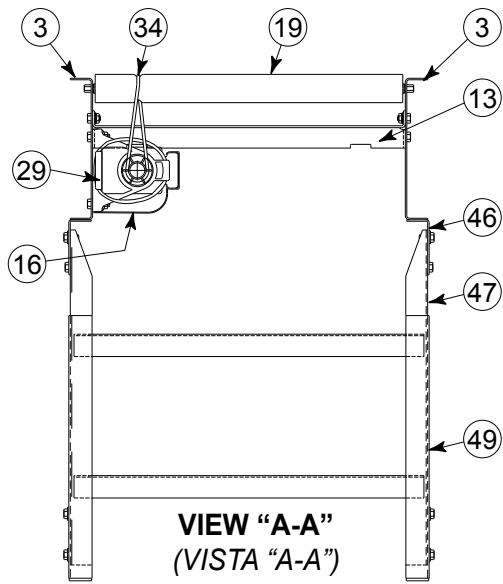
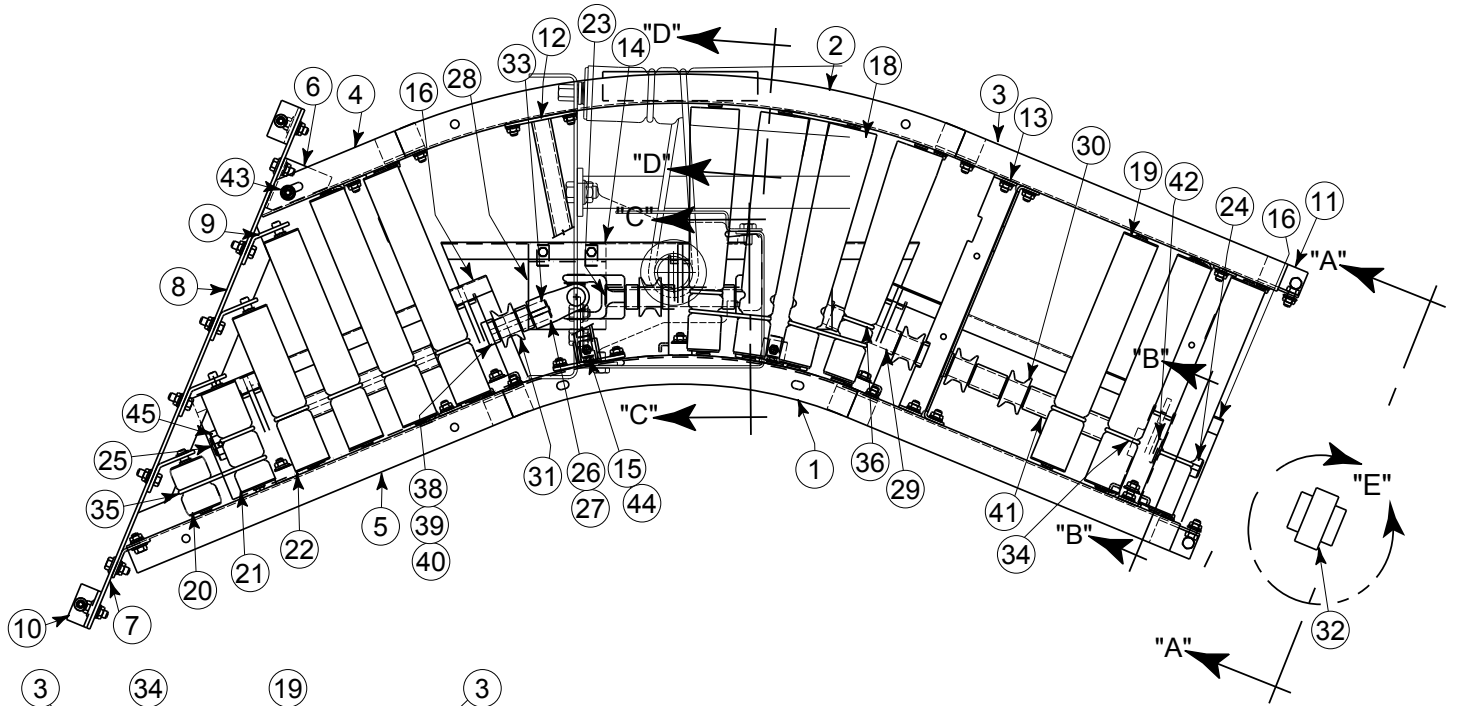



## • Model 190-NSPS 30° Parts List

## Lista de Partes del Modelo 190-NSPS 30°

Ref. No.	Part No.	Description
1	—	Inside Channel
—	B-25101	13 in BR
—	B-25103	15 in thru 27 in BR
—	B-25105	31 in thru 39 in BR
2	—	Outside Channel
—	B-25102	13 in BR
—	B-25104	15 in thru 27 in BR (Specify)
—	B-25106	31 in thru 39 in BR (Specify)
3	B-24451	Tangent Channel
4	B-25099	Short Spur Channel (Specify BR and RH or LH)
5	B-25100	Long Spur Channel (Specify Length and RH or LH)
6	B-24368	Coupling - Short Spur Channel
7	B-24355	Coupling - Long Spur Channel
8	B-24366	Spur Plate (Specify BR and RH or LH)
9	B-04519	Spur Roller Bracket
10	G-00571-012	K-Bracket - 9-1/2 in Channel
11	B-24456	Coupling Angle
12	B-24445	Bed Spacer Assembly - Curve (Specify BR)
13	B-24248	Bed Spacer Angle - Spur (Specify BR)
14	B-24454	Bed Spacer Channel - Tangent (Specify BR)
15	—	Drive Shaft Guard - Curve
—	B-24525	13 in BR
—	B-24526	15 in thru 27 in BR
—	B-24527	31 in thru 39 in BR
16	B-24449	Shaft Guard Mounting Bracket
17	B-24528	Shaft Guard Support Bracket
18	094.424	Drive Shaft Guard - Tangent (Specify Length)
19	B-25120-A	Shaft Guard Retainer Bracket - Tangent
20	B-24549	Shaft Guard Retainer Bracket - Spur
21	B-10361	1.9 in Tapered Roller - Two Grooves (Specify BR)
22	B-06535	1.9 in Dia Roller - One Groove (Specify BR)
23	G-00420-014	1.9 in Dia Roller - 1-3/4 in Between Brackets
24	B-01235-027	1.9 in Dia Roller - One Groove 3-3/8 in Between Brackets
25	B-01234-041	1.9 in Dia Roller - Two Grooves 5-1/8 in Between Brackets
26	—	1.9 in Dia Roller - One Groove
—	B-06535-055	6-7/8 in Between Rails
—	B-06535-069	8-5/8 in Between Rails
—	B-06535-083	10-3/8 in Between Rails
—	B-06535-097	12-1/8 in Between Rails
—	B-06535-111	13-7/8 in Between Rails
—	B-06535-124	15-1/2 in Between Rails
—	B-06535-138	17-1/4 in Between Rails
—	B-06535-152	19 in Between Rails
—	B-06535-166	20-3/4 in Between Rails
—	B-06535-180	22-1/2 in Between Rails
—	B-06535-194	24-1/4 in Between Rails
—	B-06535-208	26 in Between Rails
—	B-06535-221	27-5/8 in Between Rails
—	B-06535-235	29-3/8 in Between Rails
—	B-06535-249	31-1/8 in Between Rails
—	B-06535-263	32-7/8 in Between Rails
—	B-06535-277	34-5/8 in Between Rails
—	B-06535-291	36-3/8 in Between Rails
—	B-06535-305	38-1/8 in Between Rails

Ref. No.	Part No.	Description
27	—	Drive Shaft - Curve
—	B-17611-091	11-3/8 in Long (13 in BR)
—	B-17611-051	6-3/8 in Long (15 in thru 27 in BR)
—	B-17611-084	10-1/2 in Long (31 in thru 39 in BR)
28	—	Drive Shaft - Tangent
—	B-24515-095	11-7/8 in Long (13 in BR)
—	B-24515-074	9-1/4 in Long (15 in thru 27 in BR)
—	B-24515-091	11-3/8 in Long (31 in thru 39 in BR)
29	—	Drive Shaft - Spur
—	B-17611-226	28-1/4 in Long (13 in BR)
—	B-17611-397	49-5/8 in Long (15 in thru 27 in BR)
—	B-17611-582	72-3/4 in Long (31 in thru 39 in BR)
30	092.155	Universal Joint
31	049.5025	Hex Bolt - 3/8-16 x 1-3/4 in Long (Hardened)
32	B-24450	Universal Joint Guard
33	010.30116	Bearing - Glass Reinforced Nylon Housed
34	094.4101	Drive Spool - Positive Drive
35	094.410	Drive Spool
36	052.155	Chain Coupling (Includes Sprockets and Chains)
37	090.203	Shaft Key - 1/4 in Sq. 1 in. Long
38	090.256	O-Ring - 3/16 in (Drive - Tangent/Spur)
39	090.255	O-Ring - 3/16 in (Slave - Spur)
40	090.2561	O-Ring - 3/16 in (Drive - Curve)
41	090.2551	O-Ring - 3/16 in (Slave - Curve)
42	094.2510	Spool Spacer - 5/8 in Long
43	094.42523	Spool Spacer - 1-7/16 in Long
44	094.42527	Spool Spacer - 1-11/16 in Long
45	049.220	Nylon Washer - 1/8 in Thick
46	049.440	Socket Button Head Screw - 3/8-16 x 3/4 in Long
47	049.310	U-Type Nut - 1/4-20
48	098.184	Locking Collar - 1 in ID x 1-9/16 in OD x 5/8 in Long
49	—	MS Pivot Plate - 1-1/2 in Flange
—	B-00913	3-11/16 in High
—	B-002112	1-9/16 in High
50	—	Floor Support Frame
—	B-00914	6 in High (Specify OAW)
—	B-12777	7 in High (Specify OAW)
—	B-12778	8 in High (Specify OAW)
—	B-00915	9 in High (Specify OAW)
—	B-00916	11 1/2 in High (Specify OAW)
—	B-00917	14 1/2 in High (Specify OAW)
—	B-02098	18 1/2 in High (Specify OAW)
—	B-00919	22 1/2 in High (Specify OAW)
—	B-00921	32 1/2 in High (Specify OAW)
—	B-00923	44 1/2 in High (Specify OAW)
—	B-00925	56 1/2 in High (Specify OAW)
—	B-02107	68 1/2 in High (Specify OAW)
—	B-02109	78 1/2 in High (Specify OAW)
—	B-02111	90 1/2 in High (Specify OAW)
51	B-00909	Center Support Leg (Specify Length)
52	B-00911	Adjustable Foot Assembly (Specify Length)

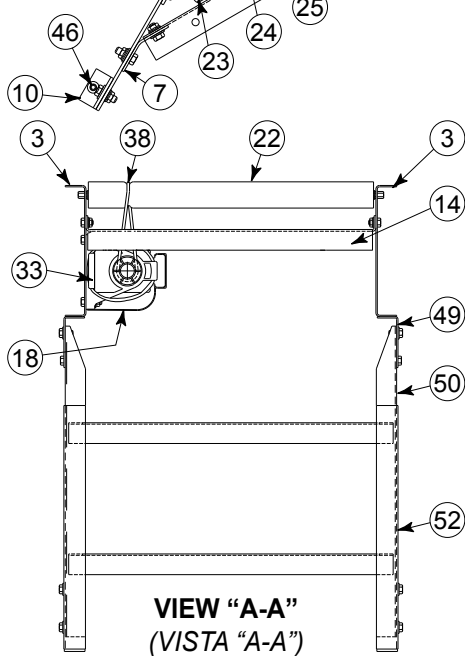
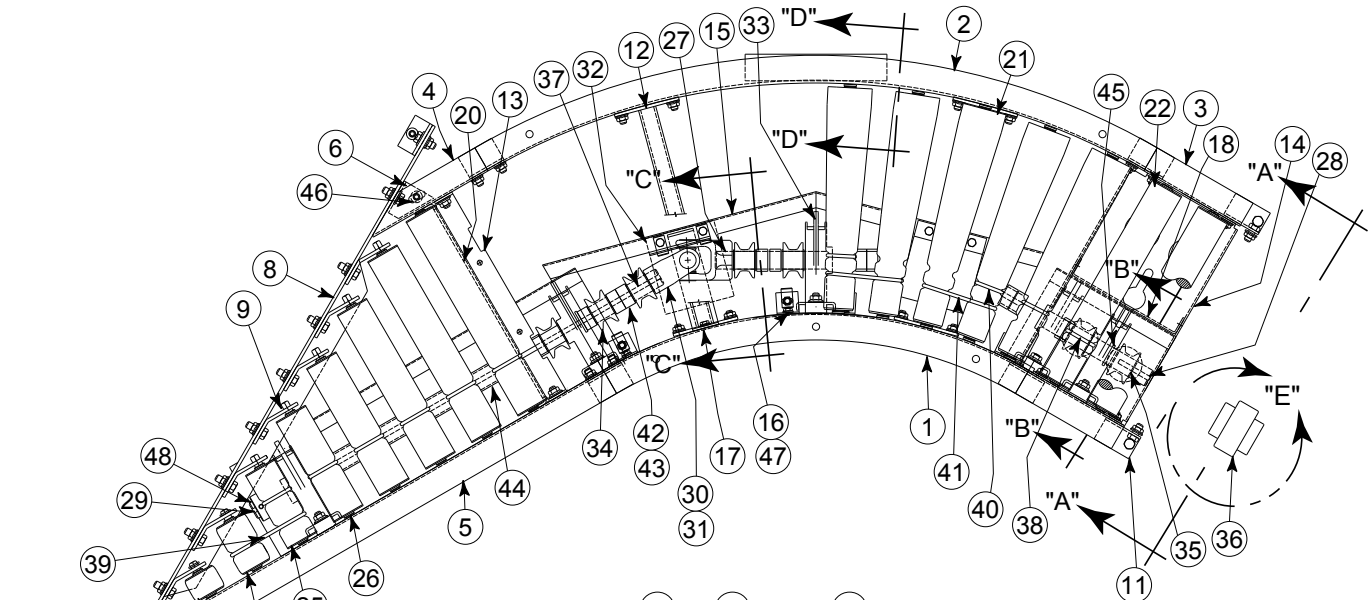

**VIEW "A-A"**  
(VISTA "A-A")

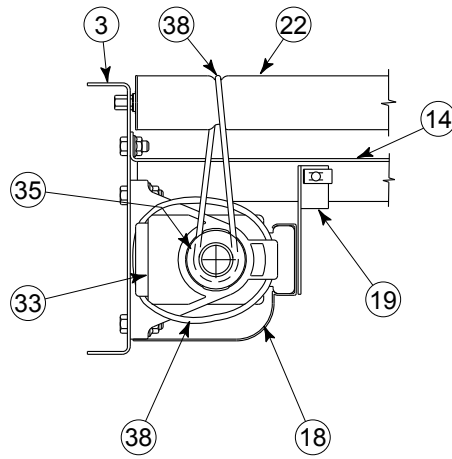

**SECTION "B-B"**  
(SECCION "B-B")

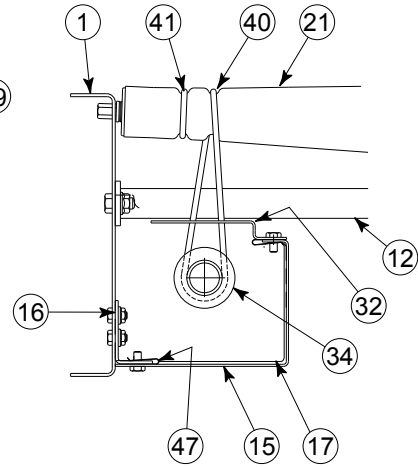

**SECTION "C-C"**  
(SECCION "C-C")

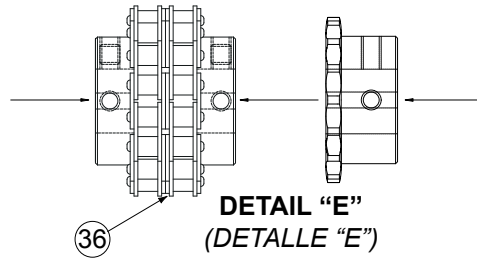

**DETAIL "E"**  
(DETALLE "E")

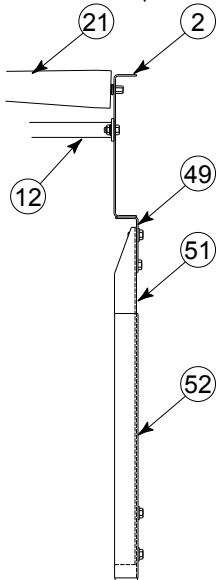

**SECTION "D-D"**  
(SECCION "D-D")

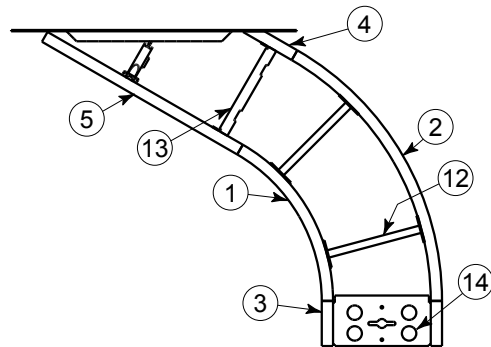

L.H.

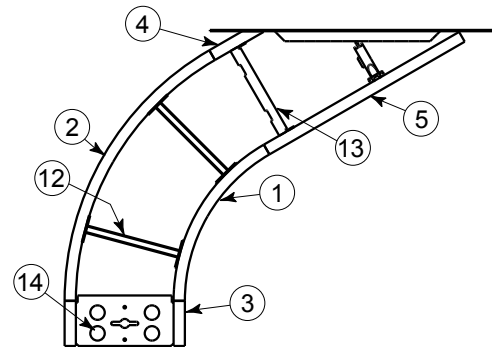

R.H.

• Model 190-NSPSS 45° Parts List

*Lista de Partes del Modelo*  
**190-NSPSS 45°**

Ref. No.	Part No.	Description
1	B-24365	Short Spur Channel (Specify BR and RH or LH)
2	—	Long Spur Channel
—	B-24363-R	RH Spur
—	B-24363-L	LH Spur
3	—	Coupling - Short Spur Channel
—	B-24369-R	RH Spur
—	B-24369-L	LH Spur
4	—	Coupling - Long Spur Channel
—	B-24356-R	RH Spur
—	B-24356-L	LH Spur
5	B-24367	Spur Plate ( Specify BR and RH or LH)
6	B-04415	Spur Roller Bracket
7	G-00571-012	K-Bracket - 9-1/2 in Channel
8	B-24268	Splice Plate
9	B-24248	Bed Spacer Angle (Specify BR)
10	094.424	Drive Shaft Guard (Specify Length)
11	B-24549	Shaft Guard Retainer Bracket
12	B-06535	1.9 in Dia Roller - One Groove (Specify BR)
13	B-01235-024	1.9 in Dia Roller - One Groove 3 in Between Brackets
14	B-01234-048	1.9 in Dia Roller - Two Grooves 6 in Between Brackets
15	—	1.9 in Dia Roller - One Groove
—	B-06535-072	9 in Between Rails
—	B-06535-096	12 in Between Rails
—	B-06535-120	15 in Between Rails
—	B-06535-144	18 in Between Rails
—	B-06535-168	21 in Between Rails
—	B-06535-192	24 in Between Rails
—	B-06535-216	27 in Between Rails
—	B-06535-240	30 in Between Rails
—	B-06535-264	33 in Between Rails
—	B-06535-288	36 in Between Rails
16	B-10674-586	Drive Shaft - 73-1/4 in Long
17	010.30116	Bearing - Glass Reinforced Nylon Housed
18	094.410	Drive Spool
19	094.4101	Drive Spool -Positive Drive
20	052.155	Chain Coupling (Includes Sprockets and Chain)
21	090.256	O-Ring - 3/16 in (Drive)
22	090.255	O-Ring - 1/8 in (Slave)
23	094.42510	Spool Spacer - 5/8 in Long
24	094.42527	Spool Spacer - 1-11/16 in Long
25	049.220	Nylon Washer - 1/8 in Thick
26	049.440	Socket Button Head Screw - 3/8-16 x 3/4 in Long
27	098.184	Locking Collar - 1 in ID x 1-9/16 in OD x 5/8 in Long
28	—	MS Pivot Plate - 1-1/2 in Flange
—	B-00913	3-11/16 in High
—	B-02112	1-9/16 in High
29	—	Floor Support Frame
—	B-00914	6 in High (Specify OAW)
—	B-12777	7 in High (Specify OAW)
—	B-12778	8 in High (Specify OAW)
—	B-00915	9 in High (Specify OAW)
—	B-00916	11 1/2 in High (Specify OAW)
—	B-00917	14 1/2 in High (Specify OAW)
—	B-02098	18 1/2 in High (Specify OAW)
—	B-00919	22 1/2 in High (Specify OAW)
—	B-00921	32 1/2 in High (Specify OAW)
—	B-00923	44 1/2 in High (Specify OAW)
—	B-00925	56 1/2 in High (Specify OAW)
—	B-02107	68 1/2 in High (Specify OAW)
—	B-02109	78 1/2 in High (Specify OAW)
—	B-02111	90 1/2 in High (Specify OAW)
30	B-00911	Adjustable Foot Assembly (Specify Length)

• Model 190-NSPSS 30° Parts List

*Lista de Partes del Modelo*  
**190-NSPSS 30°**

Ref. No.	Part No.	Description
1	B-24364	Short Spur Channel (Specify BR and RH or LH)
2	—	Long Spur Channel
—	B-24371-R	RH Spur
—	B-24371-L	LH Spur
3	B-24368	Coupling - Short Spur Channel
4	B-24355	Coupling - Long Spur Channel
5	B-24366	Spur Plate (Specify BR and RH or LH)
6	B-04519	Spur Roller Bracket
7	G-00571-012	K-Bracket - 9-1/2 in Channel
8	B-24268	Splice Plate
9	B-24248	Bed Spacer Angle (Specify BR)
10	094.424	Drive Shaft Guard (Specify Length)
11	B-24549	Shaft Guard Retainer Bracket
12	B-06535	1.9 in Dia Roller - One Groove (Specify BR)
13	G-00420-014	1.9 in Dia Roller - 1-3/4 in Between Brackets
14	B-01235-027	1.9 in Dia Roller - One Groove 3-3/8 in Between Brackets
15	B-01234-041	1.9 in Dia Roller - Two Grooves 5-1/8 in Between Brackets
16	—	1.9 in Dia Roller - One Groove
—	B-06535-055	6-7/8 in Between Rails
—	B-06535-069	8-5/8 in Between Rails
—	B-06535-083	10-3/8 in Between Rails
—	B-06535-097	12-1/8 in Between Rails
—	B-06535-111	13-7/8 in Between Rails
—	B-06535-124	15-1/2 in Between Rails
—	B-06535-138	17-1/4 in Between Rails
—	B-06535-152	19 in Between Rails
—	B-06535-166	20-3/4 in Between Rails
—	B-06535-180	22-1/2 in Between Rails
—	B-06535-194	24-1/4 in Between Rails
—	B-06535-208	26 in Between Rails
—	B-06535-221	27-5/8 in Between Rails
—	B-06535-235	29-3/8 in Between Rails
—	B-06535-249	31-1/8 in Between Rails
—	B-06535-263	32-7/8 in Between Rails
—	B-06535-277	34-5/8 in Between Rails
—	B-06535-291	36-3/8 in Between Rails
—	B-06535-305	38-1/8 in Between Rails
17	B-10674-730	Drive Shaft - 91-1/4 in Long
18	010.30116	Bearing - Glass Reinforced Nylon Housed
19	094.410	Drive Spool
20	094.4101	Drive Spool - Positive Drive
21	052.155	Chain Coupling (Includes Sprockets and Chain)
22	090.256	O-Ring - 3/16 in (Drive)
23	090.255	O-Ring - 1/8 in (Slave)
24	094.42510	Spool Spacer - 5/8 in Long
25	094.42527	Spool Spacer - 1-11/16 in Long
26	049.220	Nylon Washer - 1/8 in Thick
27	049.440	Socket Button Head Screw - 3/8-16 x 3/4 in Long
28	098.184	Locking Collar - 1 in ID x 1-9/16 in OD x 5/8 in Long
29	—	MS Pivot Plate - 1-1/2 in Flange
—	B-00913	3-11/16 in High
—	B-02112	1-9/16 in High
30	—	Floor Support Frame
—	B-00914	6 in High (Specify OAW)
—	B-12777	7 in High (Specify OAW)
—	B-12778	8 in High (Specify OAW)
—	B-00915	9 in High (Specify OAW)
—	B-00916	11 1/2 in High (Specify OAW)
—	B-00917	14 1/2 in High (Specify OAW)
—	B-02098	18 1/2 in High (Specify OAW)
—	B-00919	22 1/2 in High (Specify OAW)
—	B-00921	32 1/2 in High (Specify OAW)
—	B-00923	44 1/2 in High (Specify OAW)
—	B-00925	56 1/2 in High (Specify OAW)
—	B-02107	68 1/2 in High (Specify OAW)
—	B-02109	78 1/2 in High (Specify OAW)
—	B-02111	90 1/2 in High (Specify OAW)
31	B-00911	Adjustable Foot Assembly (Specify Length)

• Model 190-NSPSS 45° Parts Drawing *Dibujo de Partes del Modelo 190-NSPSS 45°*

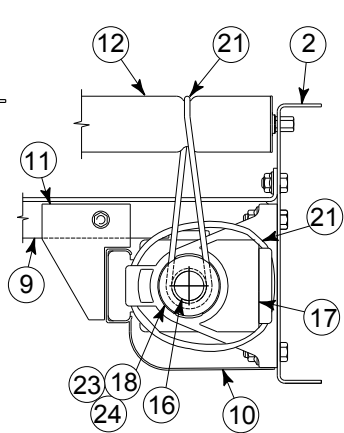
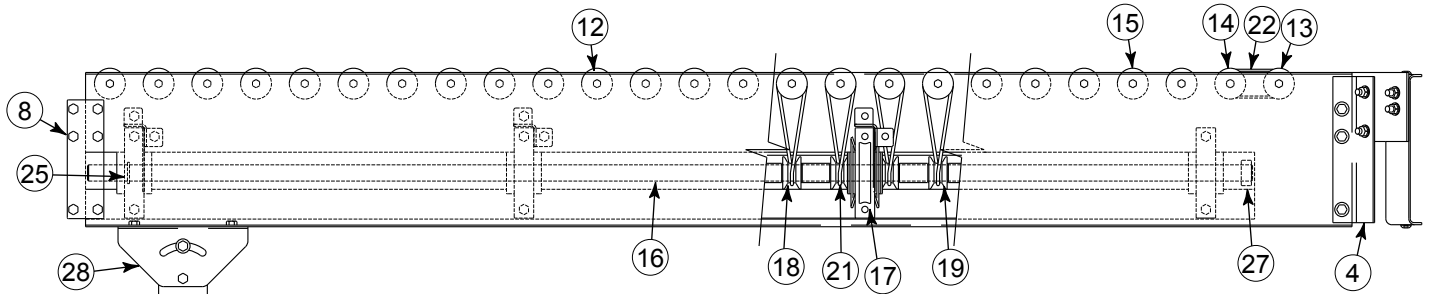
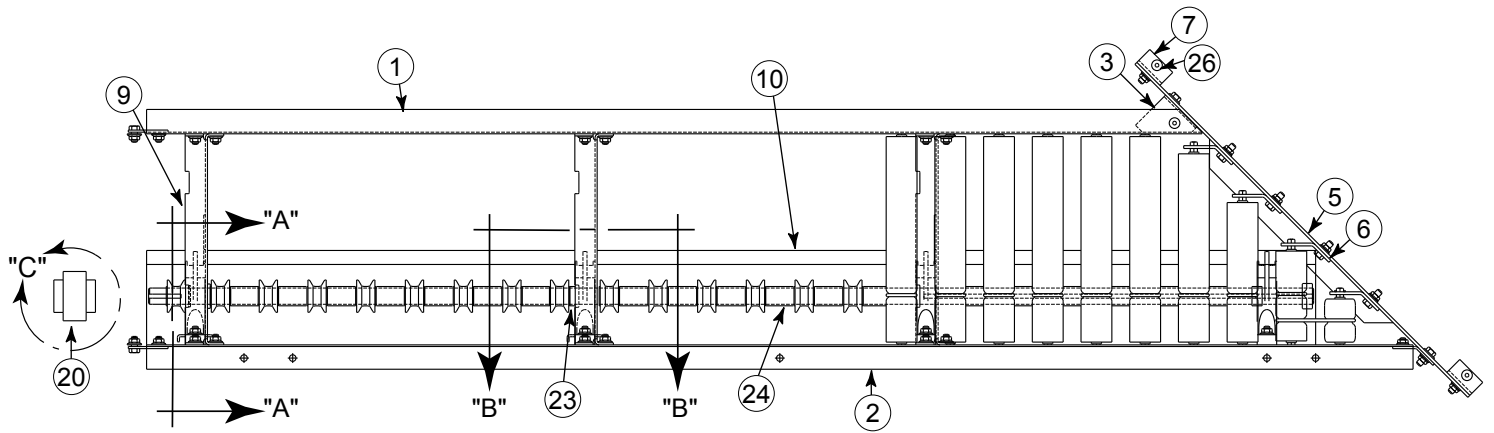

**SECTION "A-A"**  
(SECCION "A-A")

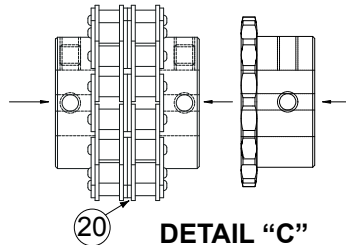
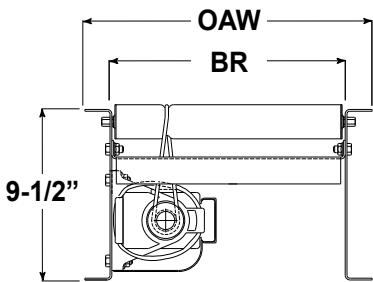
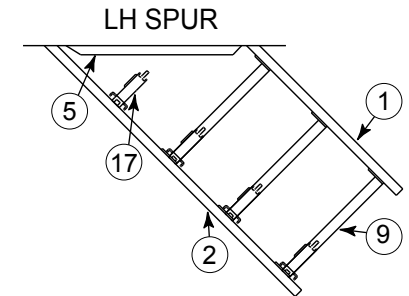
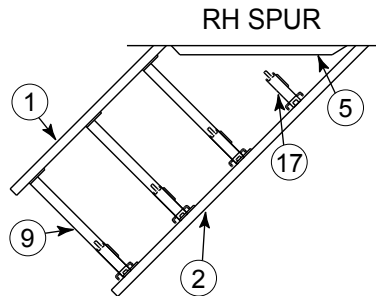

**DETAIL "C"**  
(DETALLE "C")

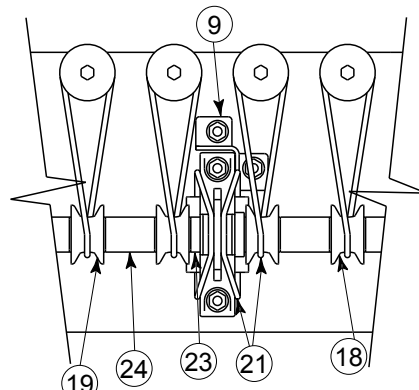

**SECTION "B-B"**  
(SECCION "B-B")

• Model 190-NSPSS 30° Parts Drawing *Dibujo de Partes del Modelo 190-NSPSS 30°*

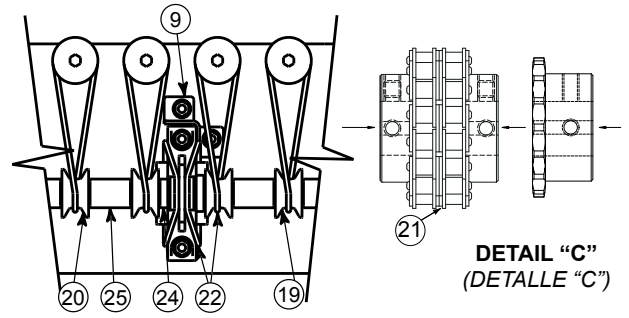
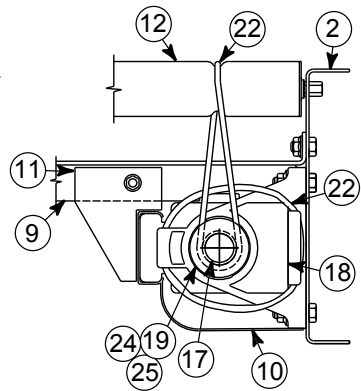
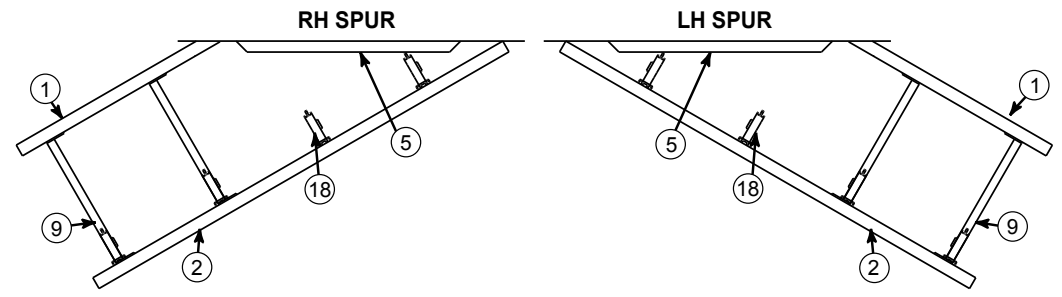
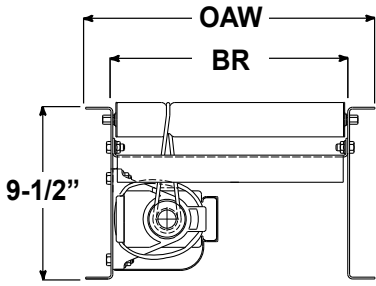
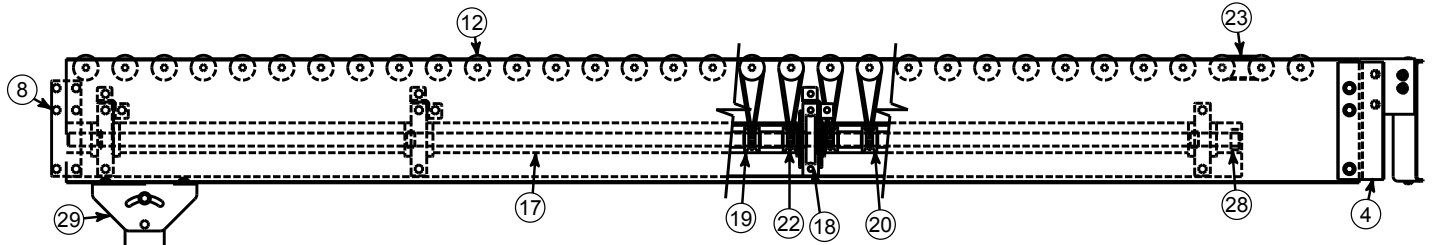
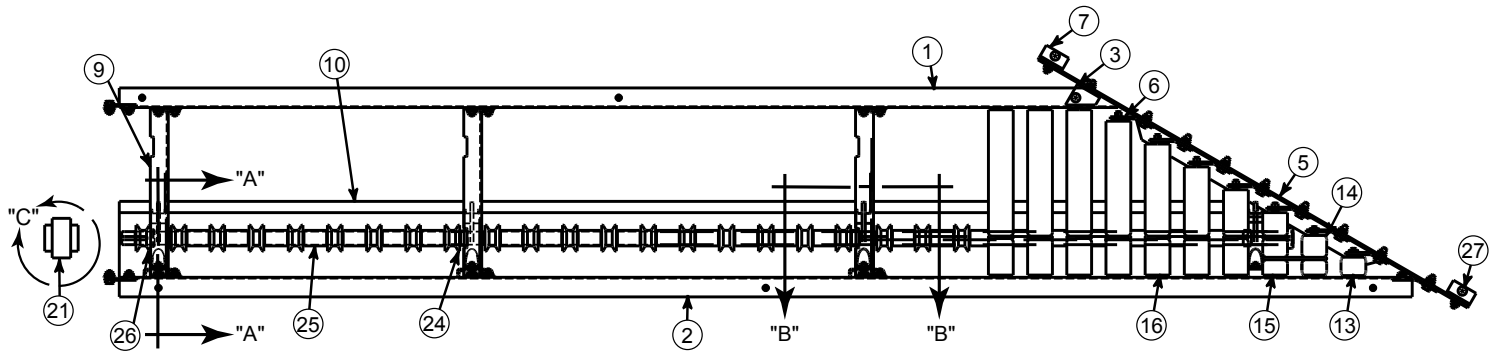

**SECTION "A-A"**  
(SECCION "A-A")

**SECTION "B-B"**  
(SECCION "B-B")

**DETAIL "C"**  
(DETALLE "C")

# ÍNDICE

## INTRODUCCION

Recepción y Desembalaje .....	22
Como Ordenar Partes de Repuesto .....	22

## INFORMACIÓN DE SEGURIDAD .....

## INSTALACIÓN

Instalación de los Soportes .....	23
Instalación de los Soportes a Tech. ....	23
Montaje .....	23, 24
Secciones Escuadradas .....	24
Equipo Eléctrico .....	24, 25

## OPERACION

Arranque del Transportador .....	25
----------------------------------	----

## MANTENIMIENTO

Lubricación .....	25
Alineación y Tensión de la Cadena .....	25, 26
Resolviendo Problemas .....	26
Lista del Plan de Mantenimiento. ....	Cubierta Posterior

## REPLACEMENT PARTS

190-NSP Dibujo de Partes .....	7
190-NSP Lista de Partes .....	8
190-NSPC 90° Dibujo de Partes .....	9
190-NSPC 90° Lista de Partes .....	10
190-NSPC 60° Lista de Partes .....	10
190-NSPC 60° Dibujo de Partes .....	11
190-NSPC 45° Dibujo de Partes .....	12
190-NSPC 45° Lista de Partes .....	13
190-NSPC 30° Lista de Partes .....	13
190-NSPC 30° Dibujo de Partes .....	14
190-NSPS 45° Lista de Partes .....	15
190-NSPS 45° Dibujo de Partes .....	16
190-NSPS 30° Lista de Partes .....	17
190-NSPS 30° Dibujo de Partes .....	18
190-NSPSS 45° Lista de Partes .....	19
190-NSPSS 30° Lista de Partes .....	19
190-NSPSS 45° Dibujo de Partes .....	20
190-NSPSS 30° Dibujo de Partes .....	21

# INTRODUCCIÓN

Este manual proporciona información para instalar, operar y dar mantenimiento a su transportador. Se proporciona una lista completa de partes, con el refaccionamiento recomendado resaltado en gris. También se proporciona información importante de seguridad a lo largo de este manual. Para seguridad del personal y para un mejor funcionamiento del transportador, se recomienda que se lean y se sigan cada una de las instrucciones proporcionadas en este manual.

## • Recepción y Desembalaje

1. Verifique el número de partes recibidas con respecto al conocimiento del embarque.
2. Examine las condiciones del equipo para determinar si algún daño ha ocurrido durante el transporte.
3. Traslade todo el equipo al área de instalación.
4. Remueva todos los empaques y verifique si hay partes adicionales que puedan estar sujetas al equipo. Asegúrese de que estas partes (u otras partes ajenas al equipo) sean removidas.

## • Cómo Ordenar Refaccionamiento

En este manual encontrará dibujos de las partes con listas completas de las refacciones. Partes pequeñas, como tornillos y tuercas no están incluidos. Para ordenar refaccionamiento:

1. Contacte al representante que le vendió el transportador o el distribuidor de Hytrol más cercano.
2. Proporcione el Modelo del Transportador y el Número de Serie o Número de la Orden de Fabricación.
3. Proporcione el Número de las partes y descripción completa que aparece en la Lista de Partes.
4. Proporcione el tipo de motor. Ejemplo- Unidad Motriz en Extremo Final de 8", Unidad Motriz Central de 8", etc.
5. Si su equipo se encuentra en una situación crítica, comuníquese con nosotros inmediatamente.

## Refaccionamiento Recomendado se Resalta en Gris

Número de Serie HYTROL

(Localizado cerca de la Unidad Motriz en Modelos motorizados).



**NOTA: Si algún daño ha ocurrido o faltan partes, contacte a su integrador Hytrol.**

# INFORMACIÓN DE SEGURIDAD

## • Instalación

### PROTECCIÓN Y SEGURIDAD

Interfaz de los equipos. Cuando dos o más piezas de equipo son interconectadas, se deberá prestar especial atención a la zona de la interfaz para asegurar la presencia de guardas y dispositivos de seguridad adecuados.

Localización o posición. Para procurar la protección de los trabajadores ante los riesgos, todas las partes móviles expuestas de la maquinaria deberán ser aseguradas mecánicamente o eléctricamente, o protegidas mediante el cambio de localización o posición.

La presencia alejada del público o empleado constituirá una medida de seguridad por ubicación.

Cuando el transportador esté instalado sobre pasillos, corredores o estaciones de trabajo; se considera protegido únicamente por localización o posición si todas las partes en movimiento están mínimo a 8 pies (2,44 m) por encima del piso o área de tránsito. De otra manera se pueden ubicar de tal manera que los empleados no entren en contacto con partes móviles peligrosas sin querer.

Aunque los transportadores aéreos pueden estar protegidos por su ubicación, deben proporcionarse guardas para evitar derrames: guardas laterales e inferiores; Esto si el producto puede caerse del transportador y así mantener al personal fuera de peligro.

### ESPACIO LIBRE SUPERIOR

Cuando los transportadores son instalados sobre pasillos, salidas o corredores; se deberá disponer de un espacio libre mínimo de 6 pies 8 pulgadas (2,032 m), medido verticalmente desde el suelo o mezanine a la parte más baja del transportador o de las guardas

Cuando el funcionamiento del sistema sea afectado al guardar la distancia mínima de 6 pies 8 pulgadas (2,032 m), deberán autorizarse pasillos alternos de emergencia.

Es posible permitir el paso bajo transportadores con menos de 6 pies 8 pulgadas (2,032 m) desde el piso, con excepción de las salidas de emergencia. Para esto se requiere una señalización apropiada que indique altura baja.

## • Operación

A) Sólo los empleados capacitados están autorizados a operar los transportadores. El entrenamiento debe incluir: operación bajo condiciones normales y en situaciones de emergencia.

B) Cuando la seguridad de los trabajadores dependa de dispositivos de paro y/o arranque, tales dispositivos deben mantenerse libres de obstrucciones para permitir un acceso rápido.

C) El área alrededor de los puntos de carga y descarga deberá mantenerse libre de obstrucciones que puedan poner en peligro al personal.

D) Ninguna persona podrá viajar en el elemento de carga de un transportador sin excepción; al menos que esta persona esté específicamente autorizado por el propietario o el empleador. En esas circunstancias, el empleado deberá montarse solamente en un transportador que tenga incorporado en sus plataformas de estructura de soporte o estaciones de control especialmente diseñadas para el transporte de personal. Esto no es permisible en un transportador vertical.

E) El personal que trabaja con un transportador, o cerca de uno; debe ser notificado de la ubicación y operación de los dispositivos de paro pertinentes.

F) Un transportador debe ser usado únicamente para transportar el material que es capaz de cargar.

G) Las indicaciones de seguridad del transportador no deben ser alteradas bajo ninguna circunstancia, especialmente si esto pone en peligro al personal.

H) Las Inspecciones de rutina, así como el mantenimiento correctivo y preventivo deben ser llevados a cabo de modo que todos los dispositivos e indicaciones de seguridad sean respetados y funcionen adecuadamente.

I) El personal debe ser notificado del peligro potencial que puede ser causado en los transportadores debido al uso de cabello largo, ropa holgada y joyería.

J) Nunca se debe dar mantenimiento o servicio a un transportador mientras se encuentre en operación, a menos que el mantenimiento o servicio apropiado lo requiera. En este caso, el personal debe ser notificado del peligro que esto representa y de cómo se puede llevar a cabo el procedimiento de la manera más segura.

K) Los dueños de los transportadores deben asegurarse de que las etiquetas de seguridad se encuentren colocadas sobre el transportador, indicando los peligros que implica la operación de sus equipos.

**¡PRECAUCIÓN! Debido a que el transportador contiene muchas partes en movimiento, todo el personal que se encuentra en el área debe ser notificado cuando el equipo esté a punto de arrancar.**

## • Mantenimiento

Todo mantenimiento, incluyendo lubricación y ajustes, debe ser llevado a cabo únicamente por personal entrenado y calificado.

Es importante que el programa de mantenimiento establecido asegure que todos los componentes del transportador reciban el mantenimiento en condiciones que no constituyan un peligro para el personal.

Cuando un transportador es detenido para propósitos de mantenimiento, los dispositivos de arranque y de potencia deben ser asegurados o etiquetados de acuerdo a un procedimiento formalizado diseñado para proteger a todas las personas o grupos que trabajan con el transportador en caso de que ocurra algún arranque inesperado.

Verifique todos los dispositivos y guardas de seguridad antes de arrancar el equipo para una operación normal.

Aunque parezca práctico, nunca lubrique los transportadores mientras se encuentran en movimiento. Sólo el personal capacitado que conoce de los peligros de un transportador en movimiento puede realizar la lubricación.

### Guardas de seguridad

Mantenga todas las guardas y dispositivos de seguridad en su posición y en buenas condiciones.

### Etiquetas de seguridad

Etiquetas de seguridad han sido ubicadas en diferentes puntos del equipo para alertar de los peligros potenciales existentes; esto en un esfuerzo por reducir la posibilidad de lesiones en el personal que trabaja alrededor de un transportador HYTROL. Por favor, revise el equipo e identifique todas las etiquetas de seguridad. Asegúrese de que el personal conozca y obedezca estas advertencias. Refiérase al manual de seguridad para ver ejemplos de etiquetas de advertencias.

**¡RECUERDE! No remueva, reúse o modifique el material que incluye el equipo para ningún propósito que no sea para el que fueron diseñados originalmente.**

**¡PRECAUCIÓN! Sólo personal capacitado debe manipular la dirección de una banda del transportador, lo cual debe hacerse mientras el transportador se encuentra en movimiento. No intente direccionar la banda si el transportador está cargado.**

# INSTALACIÓN

## • Instalación de los Soportes

1. Determine la dirección principal del flujo de producto. Figura 23A indica el flujo preferido en lo relacionado con la unidad motriz.

2. Refiérase a las "Etiquetas de Secuencia de Armado" situadas al final de las secciones del transportador (figura 23A). Posicione las secciones en la secuencia correcta cerca del área de instalación.

3. Adhiera los soportes a todas las secciones (Fig. 23A). Solo apriete los tornillos manualmente.

4. Ajuste la elevación a la altura requerida.

## • Instalación de los Soportes a Techo

Si los transportadores van a ser usados en aplicaciones aéreas o superiores, soportes a techo pudieron haber sido suministrados en lugar de los soportes de piso.

La figura 23B muestra como un soporte de techo se instala a una sección de un transportador. Los soportes deben montarse en la unión de las secciones.

**NOTA: Cuando se instalan varillas colgantes en una construcción existente, todos los métodos de unión deben cumplir con los códigos locales de construcción.**

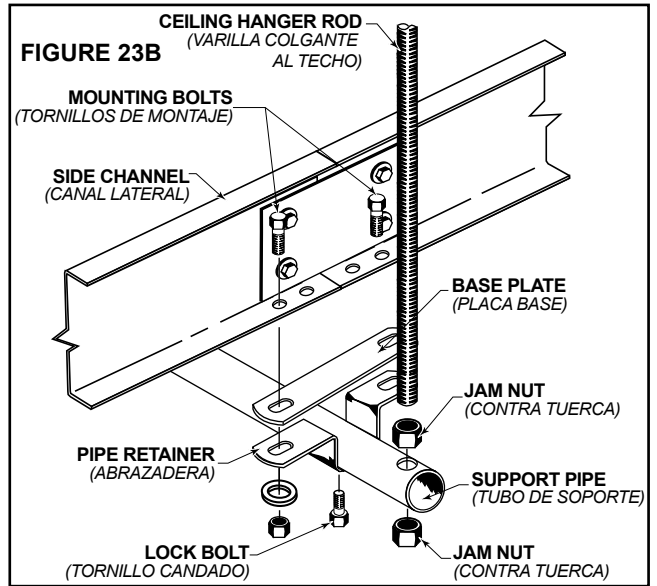

## • Montaje

1. Marque con tiza una línea en el suelo para ubicar el centro del transportador.

2. Coloque la sección motriz en su posición.

3. Instale las secciones restantes colocando el extremo sin soporte en la placa pivote del soporte de la sección anterior (Figura 23A). Revise las etiquetas de Secuencia de Armado para asegurarse que las secciones unidas estén en el orden correcto.

4. Asegure las secciones con placas de empalme y placas pivote (Figura 23B y 24C). Apriete los tornillos manualmente.

5. Revise si el transportador está nivelado a lo ancho y largo de la unidad. Ajuste los soportes como sea necesario.

6. Revise que todas las secciones de cama estén escuadradas. En la página 24 vienen instrucciones de como escuadrar las camas.

7. Apriete las placas de empalme y los tornillos de montaje del soporte y ancle el transportador al piso.

8. Revise si los ejes motrices están alineados apro-piadamante en las uniones de sección. Ajuste las catarinas de unión como se muestra en la Figura 23B, "Vista A-A". Si los ejes quedan desalineados, se causará un excesivo desgaste de la cadena de unión y las catarinas.

9. Instale la cadena de unión.

10. Instale las guardas de los ejes en los transportadores 190-NSP y 190-NSPSS (Figura 24A). Los 190-NSPC y 190-NSPS son enviados con las guardas instaladas.

11. Instale los controles eléctricos y conecte el motor. Vea la página 24-25.

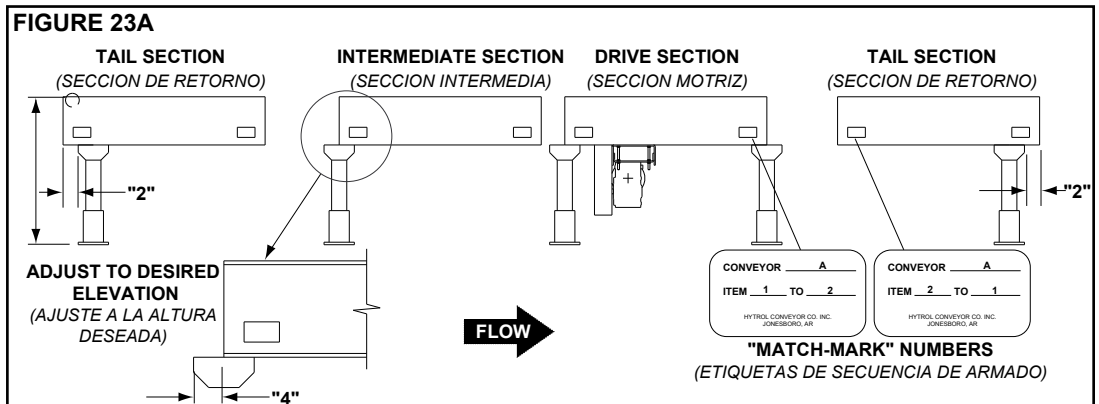

## • Montaje

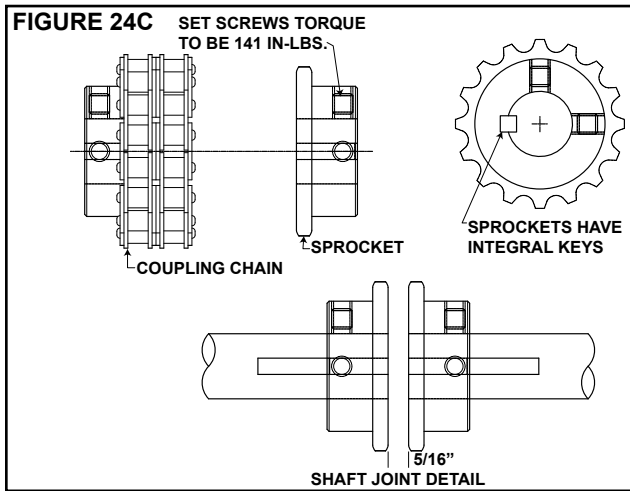
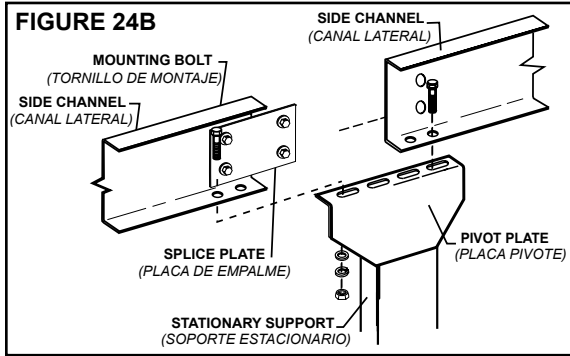
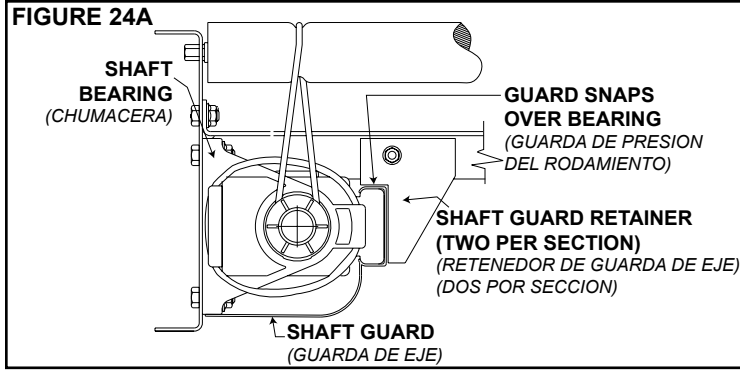

## • Secciones Descuadradas

Es importante revisar que cada sección esté escuadrada. La Figura 24D muestra una sección descuadrada.

### PARA CORREGIR UNA SECCION DESCUADRADA

1. Localice puntos en las esquinas de la sección y mida la distancia "A" y "B". Si las dimensiones no son iguales, la sección necesitará ser escuadrada. (Figura 24E).
2. Use el tirante tensor transversal suministrado en la parte inferior del transportador para escuadrar cada sección. Ajuste el tensor hasta que las dimensiones "A" y "B" sean iguales.
3. Después de que todas las secciones hayan sido verificadas y corregidas, apriete todos los tornillos de las placas de empalme y de las placas pivote.
4. Verifique que todas las secciones del transportador estén niveladas a lo ancho y a lo largo. Si todo el transportador está nivelado, los soportes pueden ser anclados al suelo.

Secciones descuadradas del transportador hacen que el producto se mueva hacia un lado del transportador.

## • Equipo Eléctrico

**¡ADVERTENCIA!** Los controles eléctricos deben ser conectados e instalados por un electricista calificado. La información sobre el cableado del motor y los controles será proporcionada por el fabricante del equipo.

### CONTROLES

Código Eléctrico: Todos los controles del motor y las conexiones deben ajustarse al Código Nacional de Electricidad, (Artículo 670 u otros artículos aplicables) como fue publicado por la Asociación Nacional de Protección Contra Incendios, y aprobado por el Instituto de Estándares Americanos.

### ESTACIONES DE CONTROL

- A) Las estaciones de control deberán estar ordenadas y ubicadas en lugares donde el funcionamiento del equipo sea visible y deberán estar claramente marcadas o señalizadas para indicar la función controlada.
- B) Un transportador que pueda causar lesiones cuando sea puesto en marcha, no deberá ponerse en funcionamiento hasta que los trabajadores en el área sean alertados por una señal o por una persona designada.

Cuando un transportador pueda causar lesiones al momento de arranque y es controlado automáticamente, o es controlado desde una ubicación lejana; se deberá proporcionar un dispositivo sonoro el cual pueda ser escuchado claramente en todos los puntos a lo largo del transportador donde el personal pueda estar presente. El dispositivo de advertencia deberá ser activado por el dispositivo de arranque del transportador y deberá continuar sonando por un determinado periodo de tiempo previo al arranque del transportador. Si es más efectivo y de acuerdo a las circunstancias se puede utilizar una luz intermitente o una advertencia visual similar, en lugar del dispositivo sonoro.

Cuando el funcionamiento del sistema pueda ser seriamente obstruido o adversamente afectado por el tiempo de retardo requerido, o cuando el intento de advertencia pueda ser mal interpretado (ej., un área de trabajo con diversas líneas de transportadores y los dispositivos de advertencia relacionados), advertencias claras, concisas y legibles deben ser proporcionadas. Las advertencias deben indicar que los transportadores y los equipos relacionados pueden ser puestos en marcha en cualquier momento, que existe un peligro y que el personal debe mantenerse alejado. Estas advertencias deben ser proporcionadas a lo largo del transportador en áreas que no sean protegidas por la posición o la ubicación.

- C) Los transportadores controlados automáticamente, desde estaciones lejanas y los transportadores donde las estaciones de funcionamiento no estén controladas por una persona o estén más allá del alcance de la voz

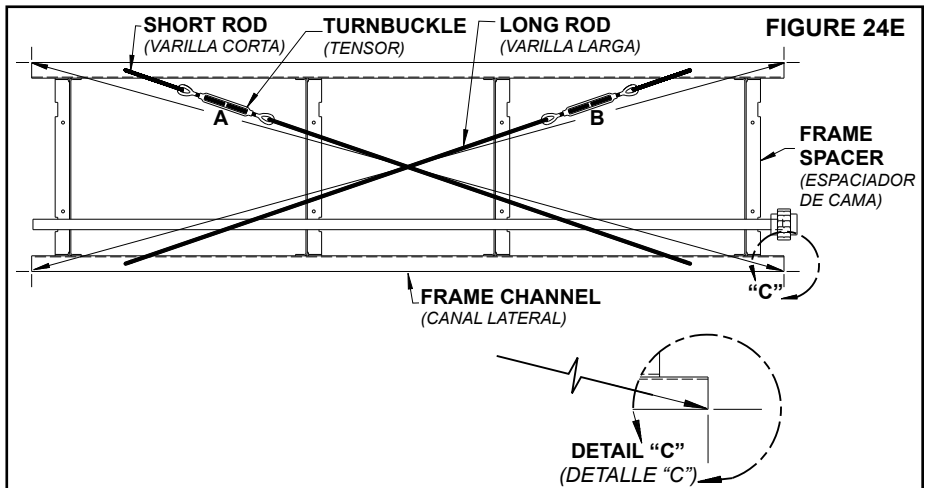
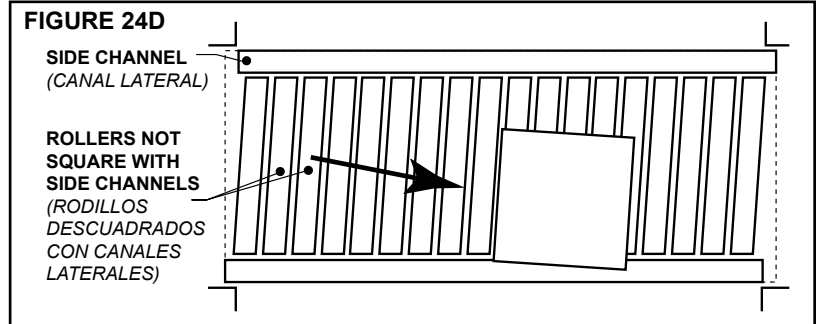

**¡IMPORTANTE!** El transportador no nivelado puede causar la desviación de las cajas en líneas largas de transportador.

**NOTA:** Las varillas se posicionan en la fábrica para que estas escuadren la sección de cama cuando son apretadas. Puede ser necesario reposicionar las varillas si la cama está descuadrada, en la dirección opuesta.



y del contacto visual de las áreas de conducción, áreas de carga, puntos de transferencia y otros sitios potencialmente peligrosos localizados en la trayectoria del transportador que no tenga protección por posición, ubicación o guardas, deberán ser equipados con interruptores de parada de emergencia, cordones de parada de emergencia, interruptores de límite o dispositivos similares para paradas de emergencia.

Todos estos dispositivos de parada de emergencia deberán ser fácilmente identificables en las cercanías inmediatas a estos puntos potencialmente peligrosos, a no ser que estén protegidos dada su ubicación, posición o protegidos con guardas. No se requieren los dispositivos de parada de emergencia donde el diseño, el funcionamiento y la operación de tales transportadores no represente un claro peligro para el personal.

El dispositivo de parada de emergencia debe actuar directamente en el control del transportador concerniente y no debe depender de la parada de cualquier otro equipo. Los dispositivos de parada de emergencia deben ser instalados de tal forma que no puedan ser anulados desde otras localidades.

D) Los controles, los actuadores inactivos o no usados y los cables, deberán ser removidos de las estaciones de control y de los tableros de mando, junto con los diagramas, indicadores, etiquetas de control y otros materiales obsoletos, los cuales pueden confundir al operador.

#### DISPOSITIVOS DE SEGURIDAD

A) Todos los dispositivos de seguridad, incluyendo la conexión de dispositivos eléctricos, deben estar dispuestos para operar en una manera de "Fallo - Seguro"; es decir, si se presenta una pérdida de corriente o una falla en el mismo dispositivo, esto no debe representar ningún peligro.

B) Paros de Emergencia y Reinicio. Los controles del transportador deberán estar dispuestos de tal manera que, en caso de un paro de emergencia se requiera un inicio o arranque manual en la ubicación donde el paro de emergencia se presentó para poder reanudar la operación del transportador o transportadores y equipo asociado.

C) Antes de volver a poner en marcha un transportador que haya sido detenido por una emergencia, debe revisarse y determinar la causa del paro. El dispositivo de arranque deberá ser bloqueado antes de intentar corregir o remover la causa que originó el paro, a no ser que la operación del transportador sea necesaria para determinar la causa o para solucionar el problema.

Refiérase a: ANS I Z244.1-1982, "American National Standard for Personnel Protection" - Lockout/Tagout of Energy Sources - Minimum Safety Requirements and OSHA Standard Number 29 CFR 1910.147 "The Control of Hazardous Energy (Lockout/Tagout)."

## OPERACION

### • Arranque del Transportador

Antes de poner en marcha el transportador, revise si hay objetos ajenos que puedan haber sido dejados dentro del transportador durante la instalación. Estos objetos pueden causar serios daños en el arranque.

Después de poner en marcha el transportador, cuando esté operando, revise los motores, reductores y partes en movimiento para estar seguro de que están trabajando libremente.

**¡PRECAUCIÓN!** Debido a la cantidad de partes en movimiento en el transportador, todo el personal en el área del transportador necesita ser advertido de que este está a punto de ponerse en marcha.

## MANTENIMIENTO

### • Lubricación

La cadena motriz ha sido pre-lubricada por el fabricante mediante un proceso de sumersión caliente que asegura una lubricación total de todos sus componentes. Sin embargo, una lubricación apropiada y continua extenderá su vida útil considerablemente.

Temperatura Ambiente (Grados F°) (Grados C°)	SAE	ISO
20-40 -07 - 04	20	46 o 68
40-100 04 - 38	30	100
100-120 38 - 49	40	150

La lubricación de la cadena motriz cumple varios propósitos:

- Proteger contra el desgaste de la unión de pines de la cadena
- Lubricar las superficies de contacto entre la cadena y la catarina
- Prevenir la oxidación o corrosión

En operaciones bajo condiciones ambientales normales, lubrique cada 2080 horas de operación o cada 6 meses, lo que ocurra primero. Hágalo con un lubricante basado en petróleo no-detergente de buen grado o sintético (ej. Shell Rotella o Mobil 1). Para mejores resultados, siempre utilice una brocha para lubricar la cadena generosamente. La viscosidad apropiada del

lubricante afecta enormemente el fluido del mismo hacia las áreas internas de la cadena. Refiérase a la siguiente tabla para consultar la viscosidad de lubricante adecuada para su aplicación.

El requerimiento de lubricación de la cadena motriz se ve afectado considerablemente por las condiciones de operación. En condiciones difíciles tales como: ambientes húmedos, ambientes con polvo, velocidades excesivas, o temperaturas elevadas, se recomienda lubricar la cadena con más frecuencia. Lo apropiado sería que bajo estas condiciones se establezca un programa de lubricación específico para su aplicación. Este programa podrá llevarse a cabo inspeccionando la lubricación suficiente de la cadena motriz en intervalos regulares de tiempo. Una vez se ha determinado el intervalo en el cual la cadena no se encuentra suficientemente lubricada, lubriquelas y programe los siguientes intervalos de acuerdo al intervalo anterior.

### • Alineación y Tensión de la Cadena Motriz

La cadena motriz y las catarinas deberán ser revisadas periódicamente para mantener una apropiada tensión y alineación. Desajustes causarán un desgaste extensivo a los componentes de la transmisión.

#### PARA HACER AJUSTES

1. Remueva la guarda de la cadena.
2. Verifique la alineación de las catarinas colocando un nivel sobre las caras de ambas catarinas. (Figura 25A). Afloje los tornillos candados y ajuste como sea necesario. Apriete nuevamente los tornillos candado.
3. Para ajustar la catarina de la flecha motriz, afloje la tuerca mas pequeña (anillo interno) de la boquilla con una llave inglesa de 1-3/4 de pulgada, mientras sujeta el otro extremo(anillo exterior) que permanece estacionario con otra llave inglesa de 1-3/4 de pulgada. Muévela a la deseada locación a lo largo de la flecha, manteniendo la cara plana de la catarina contra el hombro de las rondanas. Asegúrese que la locación de la flecha no tiene aceite, grasa o polvo. No lubrique la boquilla o la flecha. Note que a medida que anillo interno es apretado totalmente, el ensamble se moverá aproximadamente 1/16 pulgadas a lo largo de la flecha, alejándose del lado de la tuerca. Revise la alineación de la catarina, afloje y reajuste si es necesario.
4. Para ajustar la tensión de la cadena, afloje los tornillos que aseguran la base del motor con el canal del soporte. Apriete los tornillos tensores hasta alcanzar la tensión deseada (Figura 26A y 26B). Asegúrese de que ambos lados sean ajustados la misma cantidad para prevenir una mala alineación de las catarinas. Apriete los tornillos de montaje nuevamente.
5. Lubrique la cadena de acuerdo a las instrucciones de Lubricación.
6. Coloque nuevamente la guarda cadena de tal forma que no interfiera con la transmisión.

**¡PRECAUCIÓN!** Nunca remueva la guarda de la cadena mientras el transportador esté en funcionamiento. Siempre vuelva a colocar las guardas después de que los ajustes se hayan hecho.

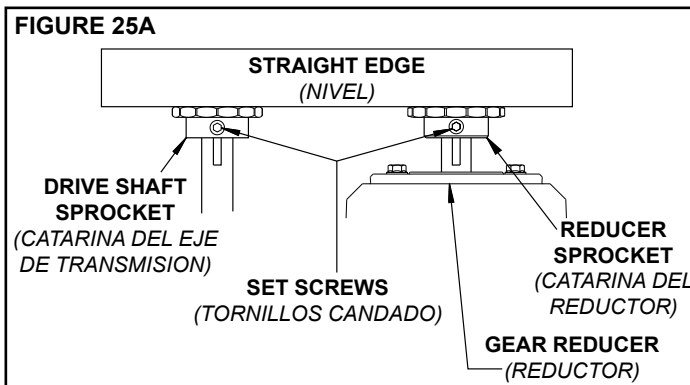

## • Alineación y Tensión de la Cadena Motriz

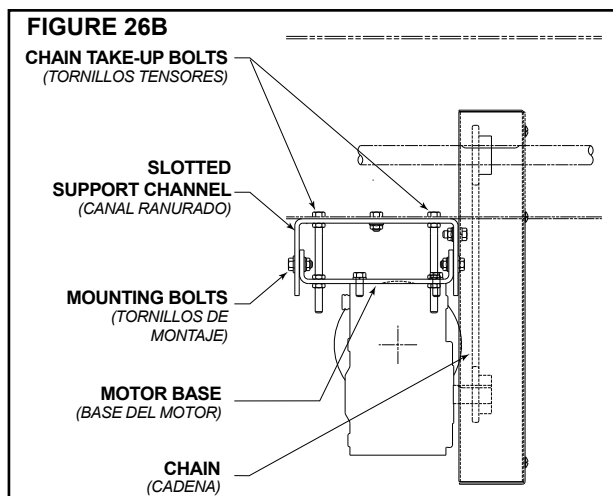
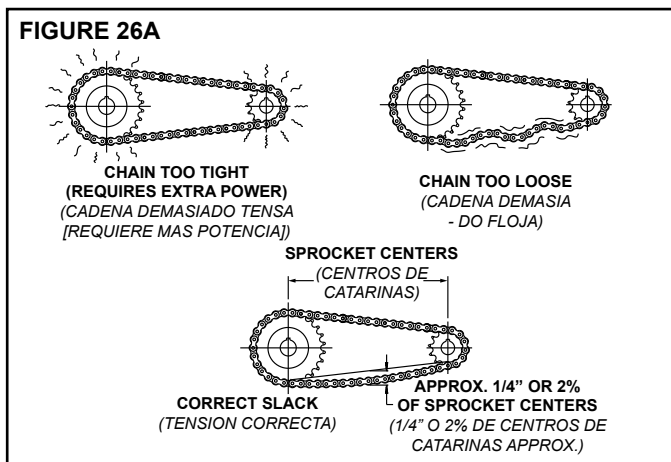

## • Resolviendo Problemas

Los siguientes cuadros describen posibles problemas que pueden ocurrir en la operación de un transportador motorizado.

RESOLVIENDO PROBLEMAS DE TRANSMISION		
PROBLEMA	CAUSA	SOLUCION
El transportador no arranca o el motor se detiene frecuentemente.	<ol style="list-style-type: none"> <li>1) El motor está sobrecargado o pasa demasiada corriente.</li> <li>2) El motor está atrayendo mucha corriente.</li> </ol>	<ol style="list-style-type: none"> <li>1) Revise si hay sobrecarga del transportador.</li> <li>2) Revise los circuitos e interruptores de protección y sobrecarga, y cámbielos si es necesario.</li> </ol>
Desgaste excesivo de la cadena motriz y las catarinas.	<ol style="list-style-type: none"> <li>1) Las catarinas están desalineadas.</li> <li>2) La cadena está floja.</li> </ol>	<ol style="list-style-type: none"> <li>1) Alinee catarinas. Vea "Alineación y Tensión de Cadena Motriz" en este manual.</li> <li>2) Tensione la cadena.</li> </ol>
Funcionamiento muy ruidoso.	<ol style="list-style-type: none"> <li>1) Rodamientos defectuosos.</li> <li>2) El tornillo candado está flojo.</li> <li>3) La cadena está floja.</li> </ol>	<ol style="list-style-type: none"> <li>1) Reemplace rodamientos.</li> <li>2) Apriete el tornillo candado.</li> <li>3) Tensione la cadena.</li> </ol>
Motor o reductor recalentado.	<ol style="list-style-type: none"> <li>1) Transportador está sobrecargado.</li> <li>2) Bajo voltaje al motor.</li> <li>3) Bajo nivel de lubricante en el reductor.</li> </ol>	<ol style="list-style-type: none"> <li>1) Revise la capacidad del transportador y reduzca la carga al nivel recomendado.</li> <li>2) Haga un chequeo por un electricista y corrija si es necesario.</li> <li>3) Vuelva a lubricar de acuerdo a las recomendaciones del fabricante. Para el reductor HYTROL, refiérase al manual adjunto.</li> </ol>
El rodillo de paso no gira cuando está cargado.	<ol style="list-style-type: none"> <li>1) Hay aceite en la línea eje.</li> <li>2) La unidad está sobrecargada.</li> <li>3) El flujo de carga está obstruido por la guarda lateral u otro objeto.</li> <li>4) El rodamiento del rodillo está defectuoso.</li> <li>5) La banda motriz está rota.</li> </ol>	<ol style="list-style-type: none"> <li>1) Limpie la línea eje con removedor de manchas K-2R o el equivalente.</li> <li>2) Revise la capacidad del transportador y reduzca la carga al nivel recomendado.</li> <li>3) Remueva la obstrucción.</li> <li>4) Reemplace el ensamble del rodillo.</li> <li>5) Reemplace la banda.</li> </ol>



## • Preventive Maintenance Checklist

### ***(Lista de Mantenimiento Preventivo)***

The following is a general maintenance checklist which covers the major components of your conveyor. This will be helpful in establishing a standard maintenance schedule.

190-NSP PLANNED MAINTENANCE CHECKLIST				
Component (Componente)	Suggested Action (Acción Sugerida)	Schedule (Horario)		
		Weekly (Semanal)	Monthly (Mensual)	Quarterly (Trimestral)
Motor	Check Noise (Revisar el Ruido)			
	Check Temperature (Revisar la Temperatura)			
	Check Mounting Bolts (Revisar los Tornillos de Montaje)			
Reducer (Reductor)	Check Noise (Revisar el Ruido)			
	Check Temperature (Revisar la Temperatura)			
	Check Oil Level (Revisar el Nivel de Aceite)			
Bearings Rodamientos	Check Noise (Revisar el Ruido)			
	Check Mounting Bolts (Revisar los Tornillos de Montaje)			
Drive Chain (Cadena Motriz)	Check Tension (Revisar la Tension)			
	Lubricate (Lubricar)			
	Check for Wear (Revisar el Desgaste)			
Sprockets (Catarinas)	Check for Wear (Revisar el Desgaste)			
	Check Set Screws & Keys (Revisar los Tornillos de fijación y prisioneros)			
Structural (Estructura)	General Check: All loose bolts, etc., tightened (Revision General: Tornillos sueltos, etc.)			

Note: Check set screws after the first 24 hours of operation.

Nota: Revise los tornillos tensores después de las primeras 24 horas de operación.

W = WEEKLY (*Semana*) M = MONTHLY (*Mensual*) Q = QUARTERLY (*Trimestral*)



A: 2020 HYTROL STREET  
JONESBORO, ARKANSAS 72401

T: (870) 935.3700  
F: (870) 931.1877

W: WWW.HYTROL.COM