

RROSD PRO PDB

USER MANUAL

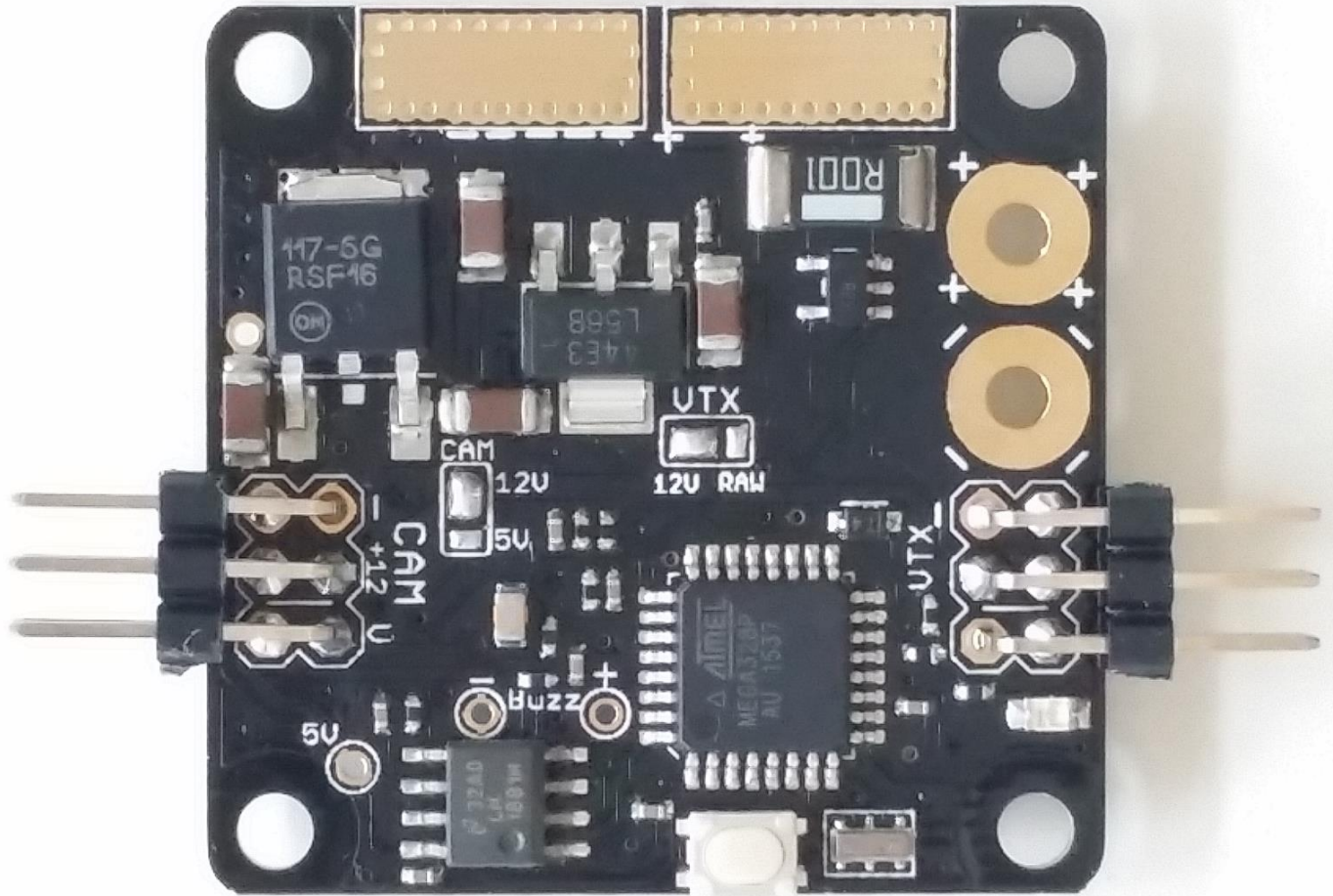

PROUDLY DESIGNED AND DISTRIBUTED BY:

REDROTOR RC

Please contact your retailer or email SUPPORT@REDROTORRC.COM if you have any questions or enquiries.

PRECAUTIONS & WARNINGS

- **Disclaimer!!** - Please understand that quadcopters are potentially dangerous machine. Use the highest level of precaution when working with hot solder iron, Lipo battery and motors. Make sure to remove props from motor throughout the entire building process.
- **Solder equipment** – Be sure to use a high quality soldering iron with a large tip especially when soldering the battery and ESC connections.
- **Power output on CAM 5V/12V connector** – Because a linear regulators are used, limit the current draw to less than 500mA on 12V and 250mA on 5V rail to prevent overheating
- **6S battery** – Please make sure VTX solder bridge is set to RAW to prevent the 12V regulator from going into thermal shutdown
- **Solder Bridge setting** – Please make sure the middle pad is only making connection to either left or right pad. Soldering all 3 pads together will effectively destroy your RROSD Pro!
- **Battery Polarity** – Be sure to hook up your battery leads to the proper pads. Positive lead is clearly marked with ++++ and Negative lead with ----. Reversing this can potentially damage your board
- **Power/Ground wire soldering** – Caution must be taken when soldering wires to the power and ground pads on the PDB. There are many sensitive components on the PDB board that a hot soldering iron can ruin or de-solder if carelessly placed
- **Return** - Due to the nature of the installation of this item requiring direct soldering, Return and Warranty claims are only considered on units that have not been soldered and within 60 days of purchase date



POWER DISTRIBUTION BOARD (PDB)

What is RROSD-PRO PDB?

Simply put, the RROSD PRO PDB is an easy to use power distribution board and OSD designed to maximize FPV experience while minimizing mini quad build time and reducing the wire clutter mess!

Built-in features

- Thick copper and wide power routing to handle the most demanding power setup
- Dimension 36mm x 36mm (30.5mm x 30.5mm mounting holes)
- Built-in power distribution regulators to handle 3S-6S
- Built in multi stages power filter for Video Transmitter and Camera with pre-installed and conveniently located connectors
- 12V and 5V output: can be used for FPV cam and accessories
- NTSC and PAL can be easily selected using the onboard button
- Plug and Play (PnP) OSD information: Flight pack voltage, current draw, total current consumption, RSSI, flight timer, Lap counter&timer
- Maximum motor current 100A total
- Automatic flight timer shows actual flight time
- The additional lost model buzzer sounds off 5 minutes after the quad has crashed.
- RSSI detection (FRsky ppm and analog compatible) displays in percentage
- Auto Battery alarm blinks the battery voltage when pack voltage hits the low limit
- Low RSSI turns on Buzzer (very handy to locate a downed quad)
- Onscreen menu allows user to calibrate pack voltage reading, current calibration, rssi input, battery alarm level...etc....
- Lap Timer onscreen counter (requires fw v4.0 or newer)
- Firmware upgradable to ensure any user can enjoy any new features that we might release the future (optional programmer is needed)
- Lost model Siren (optional Buzzer)

PDB Connection Diagram

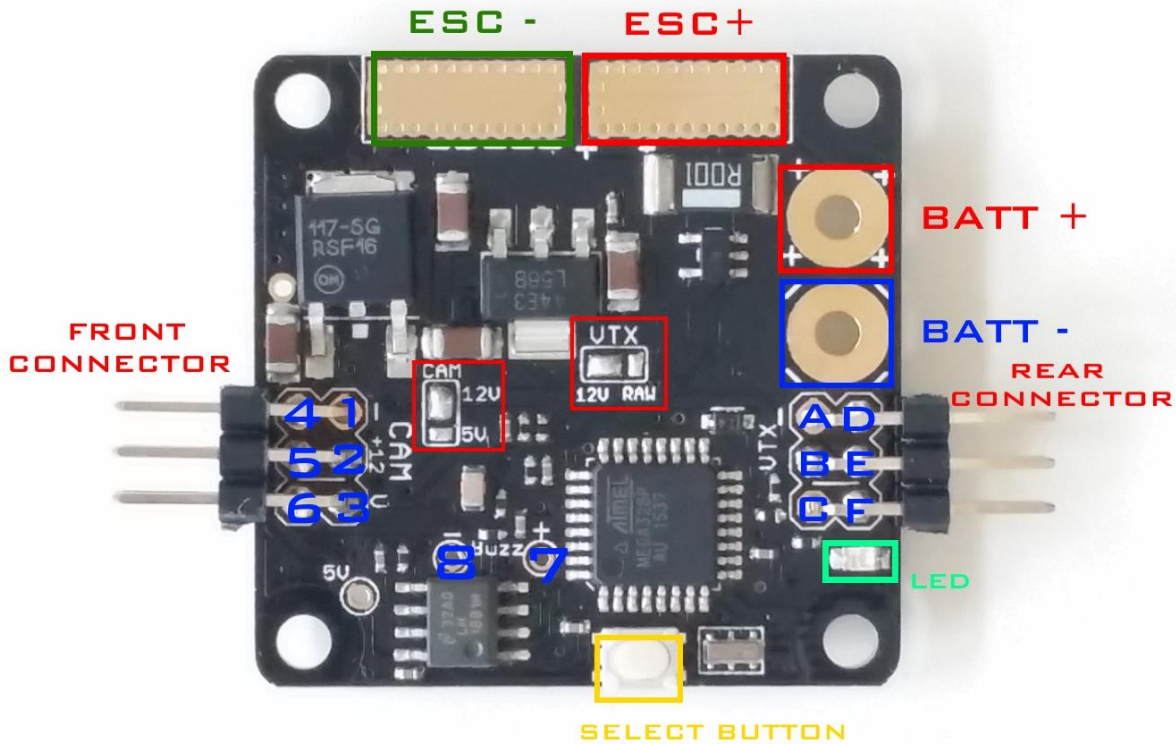

- **BATT +** => Flight battery positive input 3S – 6S
- **BATT -** => Flight battery negative input
- **ESC +** => ESCs positive input (top and bottom)
- **ESC-** => ESCs negative input (top and bottom)
- **LED** => Indicator led
- **Select Button** => Function selection button
- **Front Connector Pin Description:**
 1. Ground
 2. +12V regulated FPV camera, 500mA max
 3. Video Signal
 4. Ground
 5. +5V regulated (flight controller), 250mA max

6. RSSI Input – Use a female-female servo cable to connect to the receiver RSSI signal, pwm and analog compatible. There's a built in signal conditioning circuit to convert pwm rssi to analog voltage. Example: ch-2 on Frsky D4R receiver
 7. Buzzer +5
 8. Buzzer Ground
- **Solder Bridge Setting:**
 1. VTX – Connect Middle pad and 'RAW' or '12V' pad to set VTX voltage to Battery input and regulated 12V respectively. *Do not short all 3 pads together or very bad things will happen
 2. CAM – Connect middle pad to '5V' or '12V' pad to set CAM voltage. *Do not short all 3 pads together or very bad things will happen
 - **Rear Connector Pin Description:**
 - A. Ground
 - B. Video transmitter filtered regulated 12V power
 - C. Video transmitter video signal
 - D. Programmer DTR signal
 - E. Programmer RX signal
 - F. Programmer TX signal/Lap-Timer Input

CONTROLLING THE RROSD

*These Instructions apply to the latest FW release only. All boards are loaded with the latest release from the factory.

CHANGE VIDEO MODE (NTSC/PAL)

Hold down the Button for 10 seconds upon powering up the RROSD Pro. The LED will flash 5 times to indicate that the Video mode has been successfully changed

MENU OPERATION

To enter into the menu of the RROSD, power up the board and hold down on the button on The RROSD Pro board **within 3 seconds** of powering up. Keep it depressed until the menu appears in your view then release.

To navigate through the menu single click the button to move down an option. Long press to select an option

RSSI Calibration: To calibrate your RSSI reading, select the high reading with your radio and receiver powered on and nearby. Flip off the radio and select the low reading to calibrate the

bottom signal range. *The reading you will see on the OSD is the true received strength of the signal (more accurate and different from a 2 way telemetry signal being sent from a receiver)

Voltage Calibration: This menu item lets you calibrate your voltage reading by entering your own offset.

Current Calibration: This menu item lets you calibrate your Current reading offset from -20% to +20%

Set mAH Alarm: Allows you to set mAh consumption alarm. This will cause the respective indicator to blink on screen when the desired value is reached. We recommend setting mAH to 80% of the battery capacity

Enable Background Shade: Allows you to enable or disable the darkened bar behind the OSD text for readability under intense sunlight

Exit: Exits the Menu

LAP TIMER

*RROSD Pro FW V4.0 or newer is required in order for Lap Timer to work

The Lap Timer takes competitive fpv racing to the next level by providing the pilot with real time information on lap #, current lap time and best lap time

THE BASE STATION SETUP:

The standard Base station consists of 1 Master IR Unit and 2 IR Add-on Units. This arrangement is suitable for race gates up to 5' high and 6' wide. Additional IR Add-on modules can be daisy chained (up to 5 total), to accommodate for taller race gates. It is recommended to have an IR Add-on module for every 2' of gate height, the highest IR should be at least the same or 1' higher than the gate height

Power supply: we recommend using 2S battery of any size. Example: 2S 1000mAh can power the base station for 25 hours continuously

REDROTOR RC



IR TRANSPONDER



ADDON IRS



MASTER IR UNIT



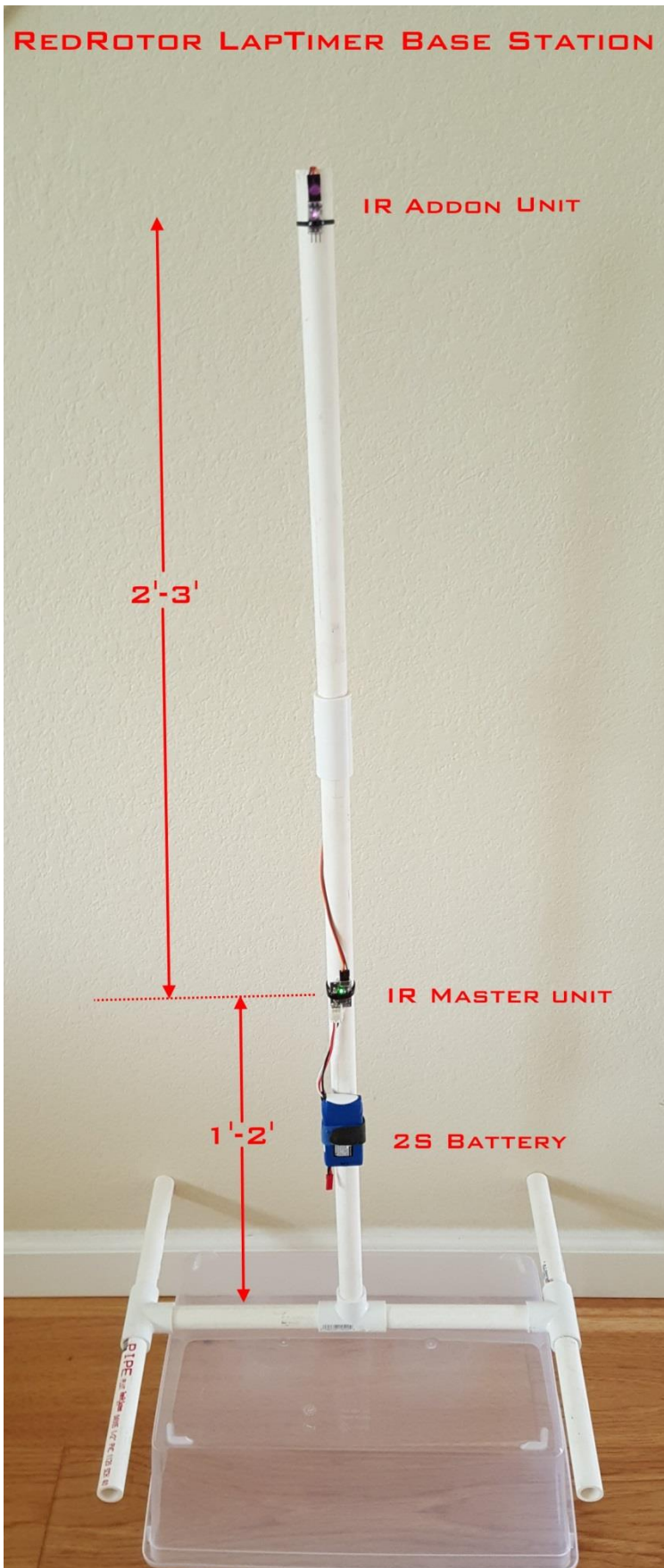

Recommended IR modules arrangement for a 5'x6' air gate

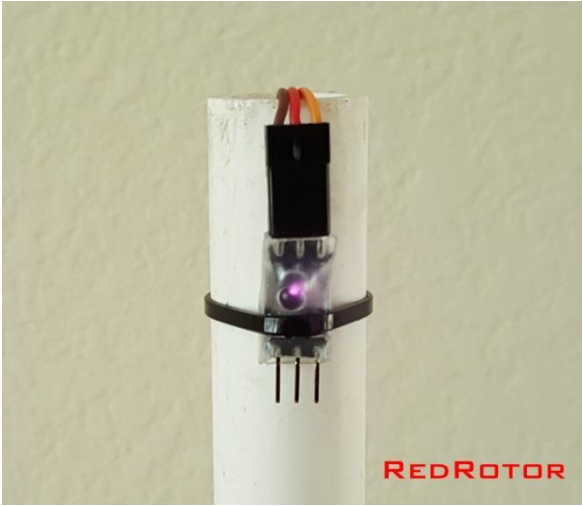
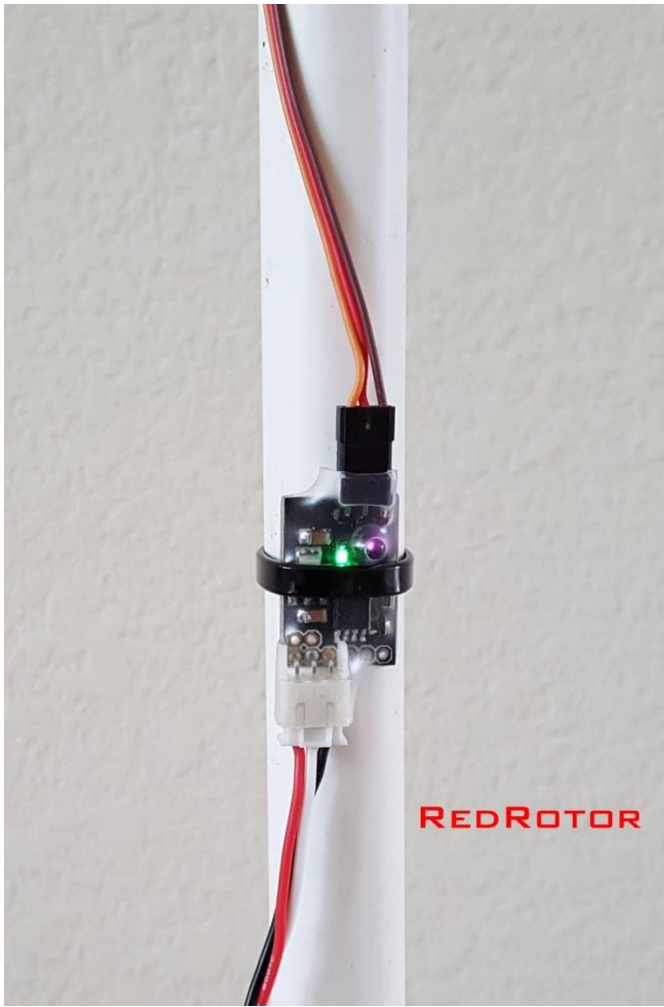

THE IR TRANSPONDER:

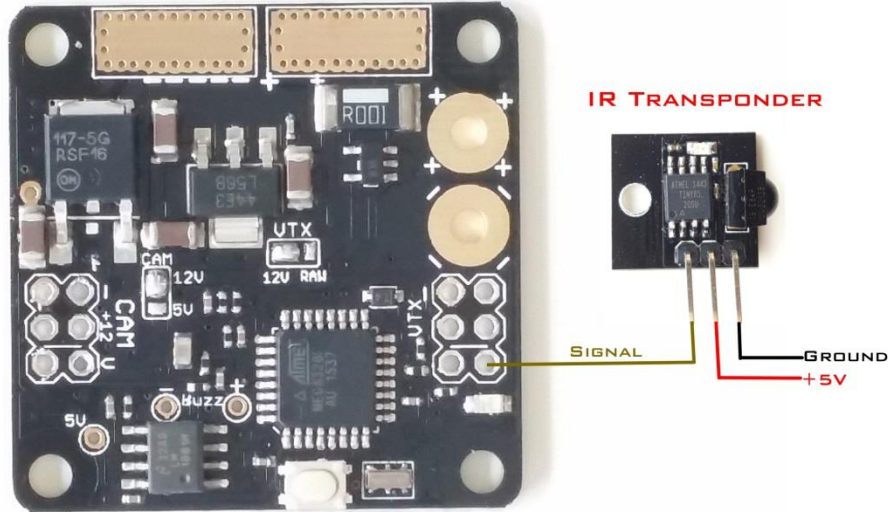

Mounting the Transponder: Choosing the location to mount the transponder is very critical in order to avoid missing counts when crossing the Base station. The transponder should be mounted in a way that the IR sensor faces outward and has a clear view of the Base station IRs when it passes through the gate. The sensor should be mounted as high and away from any obstacle (including props) as much as possible. Keep in mind that banking the quad at an extreme angle while crossing the Base station might result in missed detection

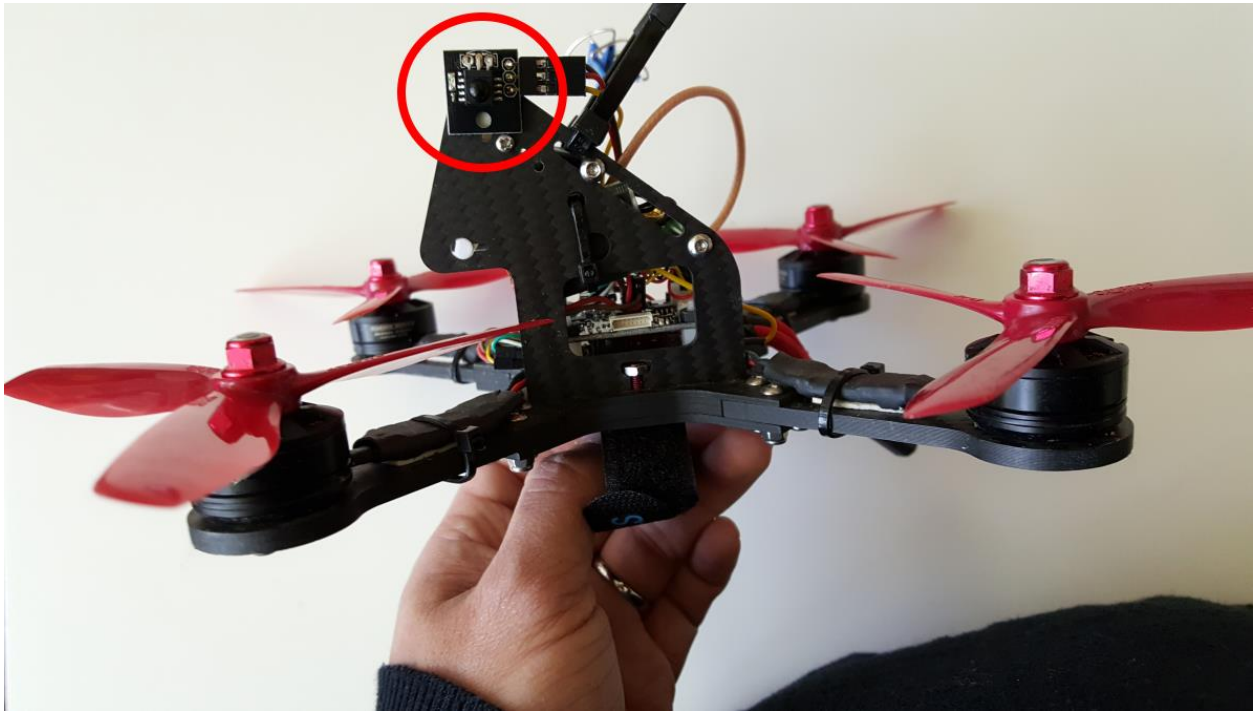

OPERATION:

The RROSD Pro auto config's the OSD text to display the appropriate Lap Timer information when the transponder is connected

FIRMWARE UPDATING

- Download the Firmware Upgrade Utility software from http://redrotorrc.com/download/RRLoader_V4.zip
- Unzip and run the installer (RRLoader.msi)
- Connect the USB-to-Serial dongle (RR-PRGM) to a PC running Win XP/7/8 and make note of the installed COM #
- You can also go Device Manager to find out the COM number

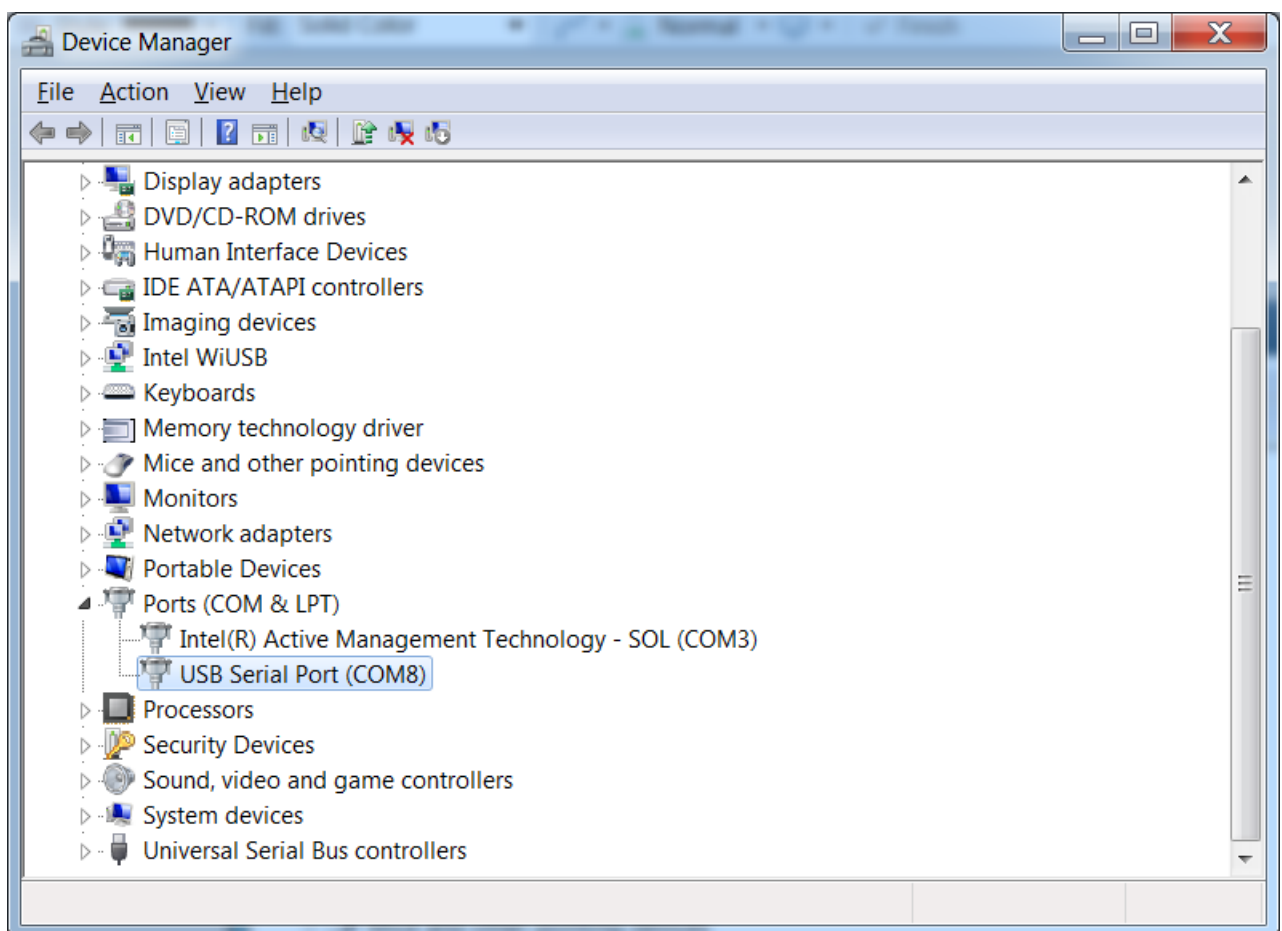

- Connect the USB dongle to RROSD Expansion port as shown. Make sure the battery is unplugged from your RROSD Pro.

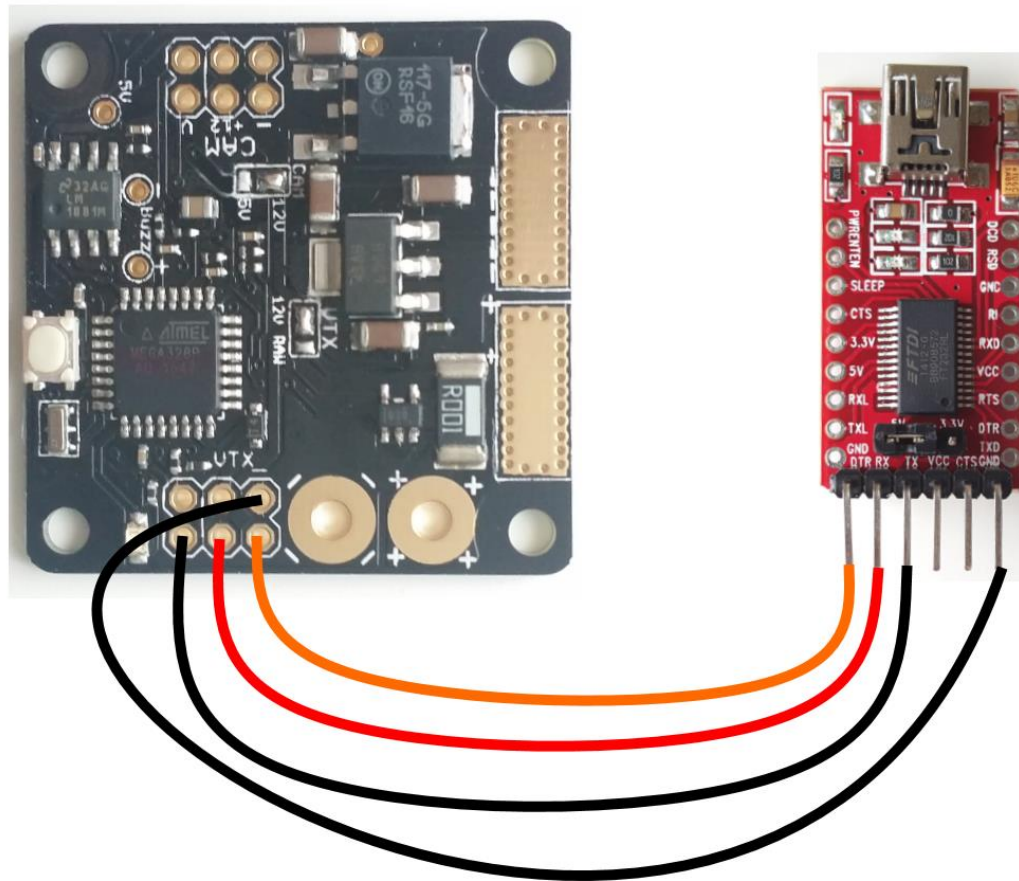

- Launch the RR Loader shortcut and enter the correct port Number.

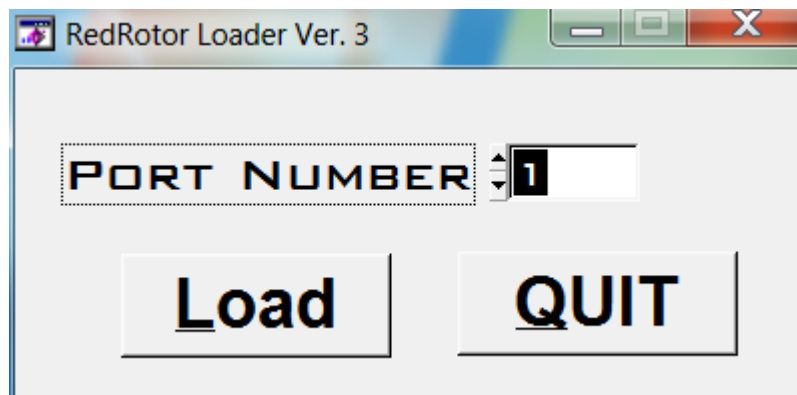

- Plug battery into RROSD Pro. (not time sensitive)
- Choose the correct COM number, and click "Load"

- Remove power and disconnect programmer from RROSD when firmware loading is finished and gives you a success message.
- Power up RROSD Pro and the OSD version listed on initial boot-up on the on screen display should be updated if everything worked correctly.
- If you get an error message make sure you COM port is correct and you've followed instructions exactly. Try a different USB port or PC and try the alternate method

TROUBLE SHOOTING

The onboard LED can provide useful information to help trouble shoot the RR

LED Behavior:

Stays full on: this means the RROSD is running but not getting valid video signal from the camera. Check camera cable

Blinks steadily: this is an indication that the RROSD is running properly and getting valid video input. Check VTX cabling and make sure channels are set correctly. Check VTX antenna to make sure there's no short

LED not on when powered up: RROSD isn't running. Check battery input cable and make sure battery is charged