

HIBLOW XP-60

Product Details:

- Includes pressure tap location for external alarm sensor
- Single air outlet
- Pumps equipped with thermal overload protection
- 6' power cord
- Quiet Operation, 35 dBA



Rated Voltage (VAC)	120
Power Consumption (Watts)	39
Rated Pressure (PSI)	2.13
Rated Air Flow (lpm @ Rated Pressures)	60
Maximum Airflow (lpm @ 0 PSI)	90
Max. Cont. Operating Pressure (PSI)	3.3
Rated Pressure Range (PSI)	0.73 - 3.41
Noise Level (dBA)	35
Weight (lbs.)	9.4



DIMENSIONS

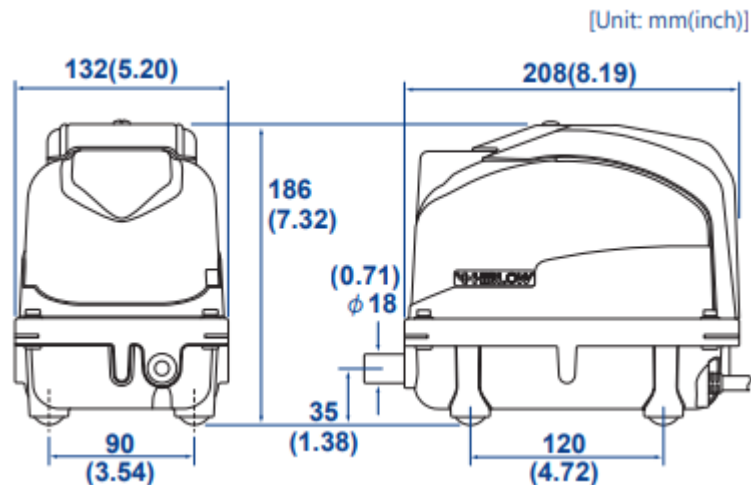

PERFORMANCE CURVES

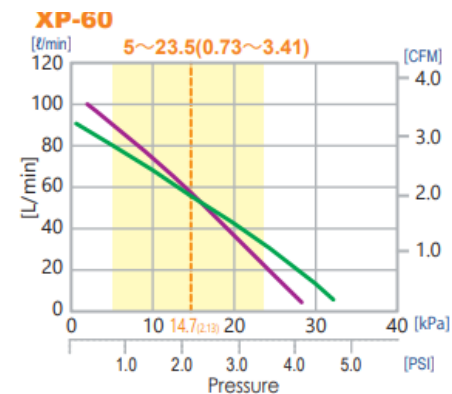

Performance Curves

